

TACT Switch™ Surface Mount Type

3.0×2.0mm Compact Type with Projection (Surface Mount)

SKSW Series

Compact, thin-profile type with a height of 0.6mm, compliant with IP6X equivalent/IPX7 (partially IPX8).

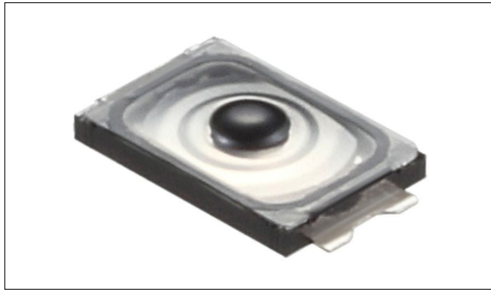

 Water-proof Type

 Dust-proof Type

- Series type: Sharp feeling type
- Absolute Maximum Ratings: 50mA 12V DC
- Rating (min.): 10μA 1V DC

Applications: Mobile: Smartphones, tablets, Headsets, wearables
 Game: Home handheld consoles, Virtual/augmented reality
 Audio_TV: Cameras

■ Product List

Products No.	Operating direction	Operating force (N)	Travel (mm)	Operating life (cycles)	Initial contact resistance	Dimensions (W×D×H) (mm)	Water-proof	Dust-proof	Water-proof & Dust-proof	Automotive	Drawing No.
SKSWCBE010	Top push	1.6	0.13	300,000	500mΩ max.	3.0×2.0×0.6	●	●	IP6X equivalent/IPX7	—	1
SKSWCEE010	Top push	1.8	0.13	300,000	500mΩ max.	3.0×2.0×0.6	●	●	IP6X equivalent/IPX7	—	
SKSWCFE010	Top push	2.4	0.13	500,000	500mΩ max.	3.0×2.0×0.6	●	●	IP6X equivalent/IPX7	—	
SKSWCGE010	Top push	3.3	0.13	300,000	500mΩ max.	3.0×2.0×0.6	●	●	IP6X equivalent/IPX7	—	
SKSWDAE010	Top push	2.4	0.13	300,000	500mΩ max.	3.0×2.0×0.6	●	●	IP6X equivalent/IPX8	—	2

Note

1. This catalog shows only outline specifications. When using the products, please obtain formal specifications for supply.
2. Please place purchase orders for taping products per minimum order unit (1 reel or a case).
3. Protective structure :
 Assumes the switch is left alone without being operated. Under the specified conditions, dust and water ingress with a significant impact on the switch's on-off function is prevented.
 IP6X equivalent/IPX7, or IP6X equivalent/IPX8, dust and water resistance is guaranteed for the switch alone and performance may not be guaranteed depending on the mounting conditions and usage.

■ Packing Specifications

Taping

Number of packages (pcs.)			Tape width (mm)	Export package measurements (mm)
1 reel	1 case / Japan	1 case / export packing		
20,000	200,000	200,000	12	395 x 395 x 205

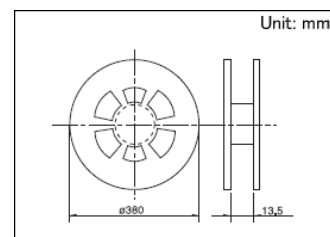

TACT Switch™ Surface Mount Type

3.0x2.0mm Compact Type with Projection (Surface Mount)

SKSW Series

Drawing No.1

■ Dimensions

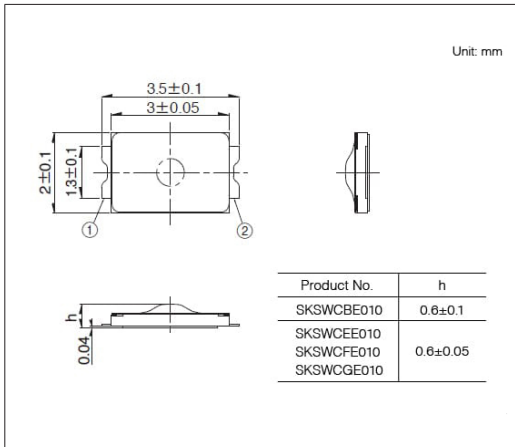

■ Land Dimensions

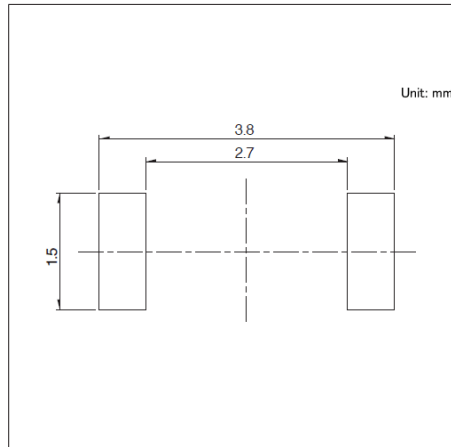

■ Circuit Diagram

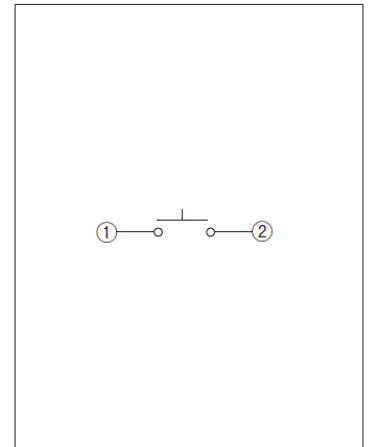

Viewed from mounting face.

Drawing No.2

■ Dimensions

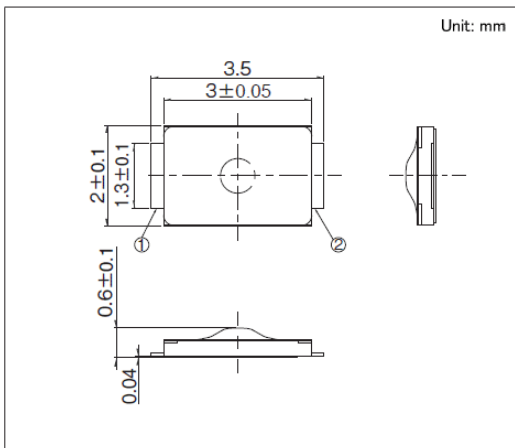

■ Land Dimensions

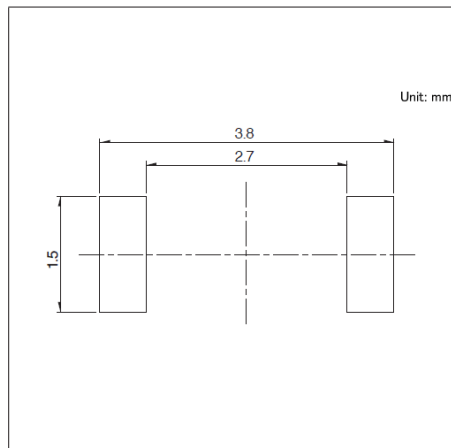

■ Circuit Diagram

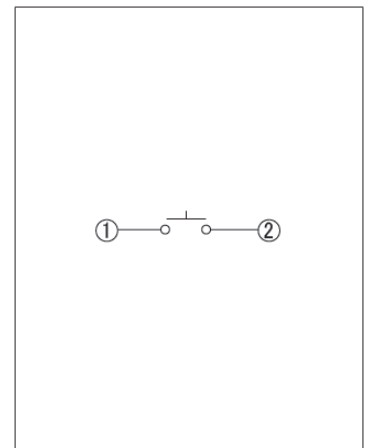

Viewed from mounting face.