

COMPONENT PRODUCTS CATALOG

English

Sensors

TACT Switch™

Switches

Encoders

Potentiometers

Multi Control Devices

haptic reactor

Connectors





■ Sensors	3
Magnetic Sensors	4
Geomagnetic Sensors	11
Humidity Sensors	13
Pressure Sensors	18
Resistive Position Sensors	23
■ TACT Switch™	37
Snap-in Type	38
Surface Mount Type	62
Radial Type	124
■ Switches	128
Detector Switches	129
Slide Switches	239
Push Switches	291
Rotary Switches	320
■ Encoders	337
Metal shaft Encoder	338
Insulated shaft Encoder	347
Through shaft Encoder	356
Ring Encoder	362
■ Potentiometers	378
Rotary Potentiometer (Metal shaft type)	379
Rotary Potentiometer (Insulated shaft type)	399
Rotary Potentiometer (Knob operating type)	414
Rotary Potentiometer (Ring type)	419
Slide Potentiometer (Standard type)	424
Slide Potentiometer (Master type)	437
■ Multi Control Devices	447
Potentiometer Type	448
Switch Type	453
■ haptic reactor	466
haptic reactor	467
■ Connectors	472
Spring Contact	473
▪ Explanation of Terms	477
▪ Precautions when handling our products	485
▪ Cautions for using this catalog	485

Sensors

● Magnetic Sensors	4
● Geomagnetic Sensors	11
● Humidity Sensors	13
● Pressure Sensors	18
● Resistive Position Sensors	23

Magnetic Sensors

List of Varieties

Series	HGDE*/HGDF*	HGAR	HGDVST	HGPRDT
Photo				
Package specifications	MAP type SOT23 type	DFN type MSOP type TSSOP8 type TSSOP16 type	SOT23 type	
Type	Switching (Surface mount)	Angle (Surface mount)	Switching (Surface mount)	Encoder (Surface mount)
Dimensions (mm)	1.3×0.9×0.525 2.9×2.8×1.1	1.8×1.05×0.65 2.95×4.0×1.1 3.0×4.9×1.1 5.0×6.4×1.1	2.9×2.8×1.1	
Function	Dual polarity/Dual output Dual polarity/Single output Single polarity/Single output	Sin/Cos output Sin/Cos output x2	Single polarity/Single output	2-phase alternating output Alternating output/ Direction of rotation output
Operating magnetic field	1.3mT 2.0mT 3.0mT	10 to 120mT 20 to 60mT	Hoff typ. 1.4mT Hon typ. 2.0mT	Hoff: -0.8mT Typ Hon: +0.8mT Typ
Drive voltage	Typ. 1.8V (1.6V min. to 3.6V max.) Typ. 5V (4.5V min. to 5.5V max.)	5.5V max.	3 to 30V	12V Typ. (3 to 30V)
Current consumption	3μA Ave (at VDD=1.8V) Typ. 1.65mA (at VDD=5V)	—	2.5mA Max. (at VDD=12V)	1.6mA Typ. (at VDD=12V)
Operating temperature range	-10°C to +85°C -40°C to +85°C	-40°C to +105°C -40°C to +150°C	-40°C to +140°C (at VDD=9V)	
Automotive	—	○	●	●

Note

● Indicates applicability to all products in the series, while ○ indicates applicability to some products in the series.

Switching Output Type HGDE*/HGDF* Series

High reliability with a compact, thin profile based on magnetic sensing device technology.

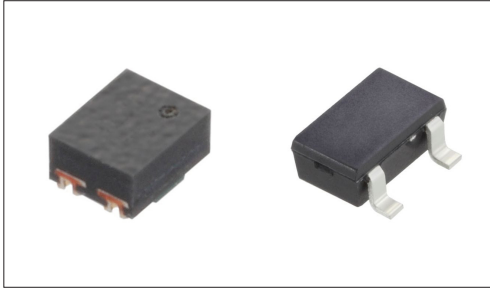

■ Type: Switching (Surface mount)

Applications: Game: Virtual/augmented reality
Healthcare: Healthcare equipment, Nursing care equipment,
Analysis, test equipment
Home: Major home appliances
Audio_TV: Visual, Audio, Pro audio, Cameras
Mobile: Notebooks, peripherals

■ Product List

Products No.	Package specifications	Function	Operating magnetic field	Drive voltage	Current consumption	Size (mm)	Automotive	Drawing No.
HGDESM013A	MAP type	Single polarity/Single output	1.3mT	Typ. 1.8V (1.6V min. to 3.6V max.)	3μA Ave (at VDD=1.8V)	1.3×0.9×0.525	—	1
HGDEPM013A	MAP type	Dual polarity/Single output	1.3mT	Typ. 1.8V (1.6V min. to 3.6V max.)	3μA Ave (at VDD=1.8V)	1.3×0.9×0.525	—	
HGDEDM013A	MAP type	Dual polarity/Dual output	1.3mT	Typ. 1.8V (1.6V min. to 3.6V max.)	3μA Ave (at VDD=1.8V)	1.3×0.9×0.525	—	
HGDESM023A	MAP type	Single polarity/Single output	2.0mT	Typ. 1.8V (1.6V min. to 3.6V max.)	3μA Ave (at VDD=1.8V)	1.3×0.9×0.525	—	
HGDESM033A	MAP type	Single polarity/Single output	3.0mT	Typ. 1.8V (1.6V min. to 3.6V max.)	3μA Ave (at VDD=1.8V)	1.3×0.9×0.525	—	
HGDEST021B	SOT23 type	Single polarity/Single output	2.0mT	Typ. 1.8V (1.6V min. to 3.6V max.)	3μA Ave (at VDD=1.8V)	2.9×2.8×1.1	—	2
HGDEPT021B	SOT23 type	Dual polarity/Single output	2.0mT	Typ. 1.8V (1.6V min. to 3.6V max.)	3μA Ave (at VDD=1.8V)	2.9×2.8×1.1	—	
HGDFST021B	SOT23 type	Single polarity/Single output	2.0mT	Typ. 5V (4.5V min. to 5.5V max.)	Typ. 1.65mA (at VDD=5V)	2.9×2.8×1.1	—	3
HGDFPT021B	SOT23 type	Dual polarity/Single output	2.0mT	Typ. 5V (4.5V min. to 5.5V max.)	Typ. 1.65mA (at VDD=5V)	2.9×2.8×1.1	—	

⚠ Note

1. This catalog shows only outline specifications. When using the products, please obtain formal specifications for supply.
2. Please place purchase orders per minimum order unit (integer).
3. High and low sensitivity types also available. Please contact us for details.
4. Some products can be provided halogen-free. Please contact us for details.

■ Packing Specifications

Taping

Number of packages (pcs.)			Tape width (mm)	Export package measurements (mm)
1 reel	1 case / Japan	1 case / export packing		
3,000	3,000	45,000	8	210 x 210 x 230

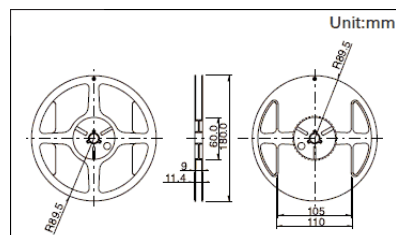

Sensors **Magnetic Sensors**

Switching Output Type
HGDE*/HGDF* Series

Drawing No.1

■ Dimensions

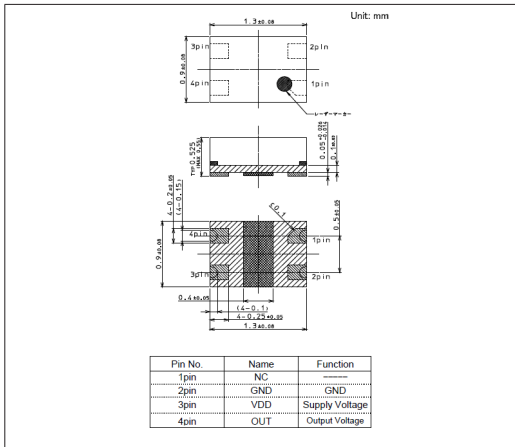

■ Land Dimensions

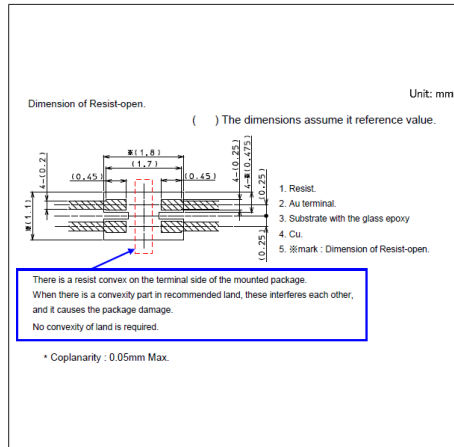

Drawing No.2

■ Dimensions

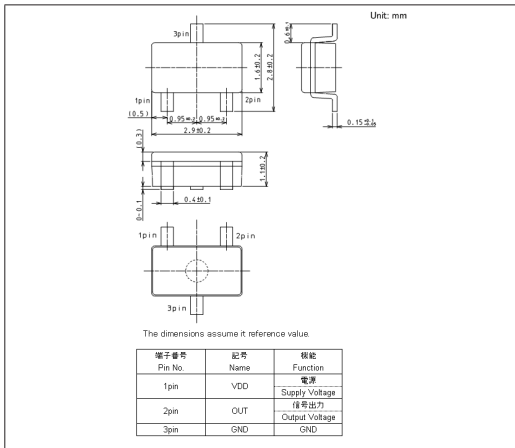

■ Land Dimensions

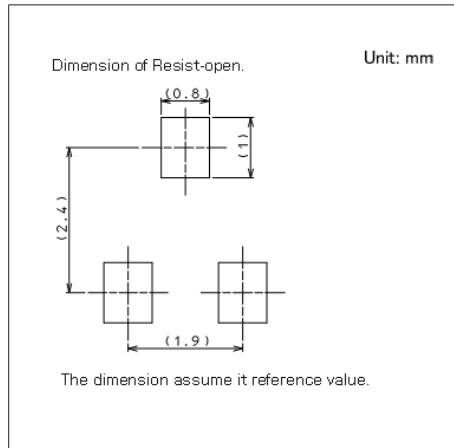

Drawing No.3

■ Dimensions

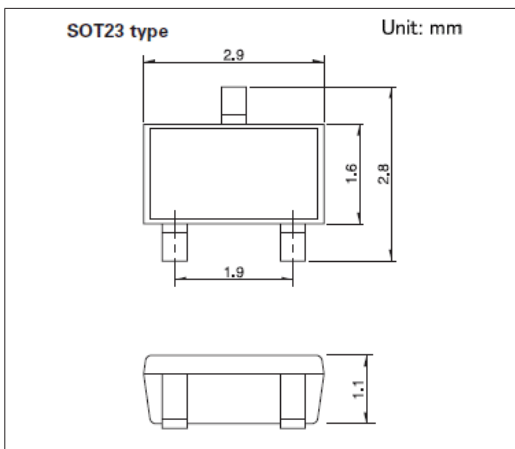

■ Land Dimensions

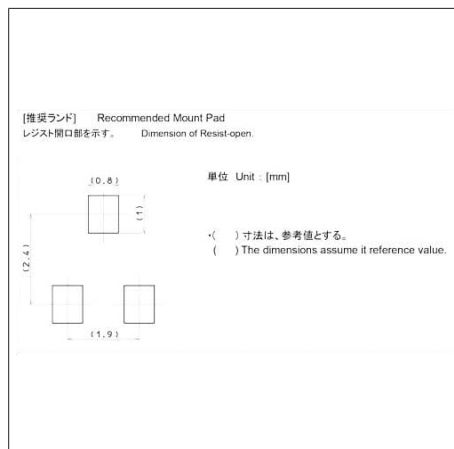

Sensors Magnetic Sensors

Analog Linear Output Type
HGAR Series

High output suitable for high-resolution absolute angle and position detection.

 Automotive

※Please check the product list for compatible products

■ Type: Angle (Surface mount)

Applications: Energy_Industrial: Robots, drones, Industrial equipment, Converters
 Game: Virtual/augmented reality
 Healthcare: Healthcare equipment, Nursing care equipment, Analysis, test equipment
 Automotive: Navigation/audio systems, HVAC, Shifter, Steering

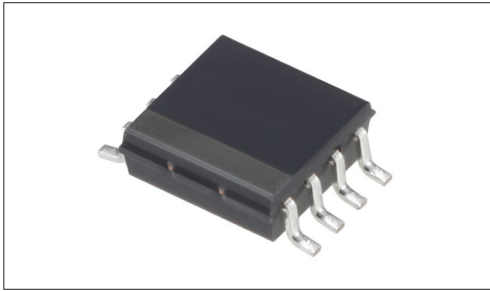

■ Product List

Products No.	Package specifications	Function	Operating magnetic field	Drive voltage	Size (mm)	Automotive	Drawing No.
HGARPS011A	TSSOP8 type	Sin/Cos output	10 to 120mT	5.5V max.	3.0×4.9×1.1	●	1
HGARPS001A	TSSOP16 type	Sin/Cos output x2	10 to 120mT	5.5V max.	5.0×6.4×1.1	●	2
HGARAP001A	MSOP type	Sin/Cos output	20 to 60mT	5.5V max.	2.95×4.0×1.1	●	3
HGARAN008A	DFN type	Sin/Cos output	20 to 60mT	5.5V max.	1.8×1.05×0.65	—	4

 Note

1. This catalog shows only outline specifications. When using the products, please obtain formal specifications for supply.
2. Place your purchase order in N minimum package units (N: integer).

■ Packing Specifications

Taping

Products No.	Number of packages(pcs.)			Tape width (mm)	Export package measurements (mm)
	1 reel	1 case / Japan	1 case / export packing		
HGARPS011A	3,000	3,000	21,000	12	378×381×276
HGARPS001A	2,500	2,500	10,000	12	284×224×278
HGARAP001A	3,000	3,000	3,000	12	210 x 210 x 230
HGARAN008A	3,000	3,000	3,000	8	210 x 210 x 230

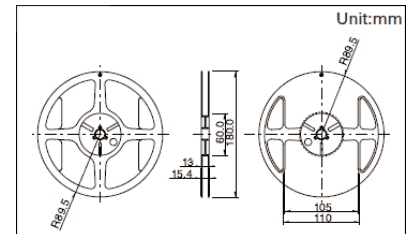

Drawing No.1

■ Dimensions

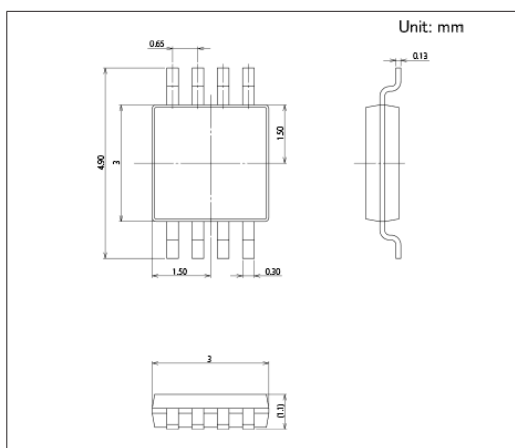

■ Land Dimensions

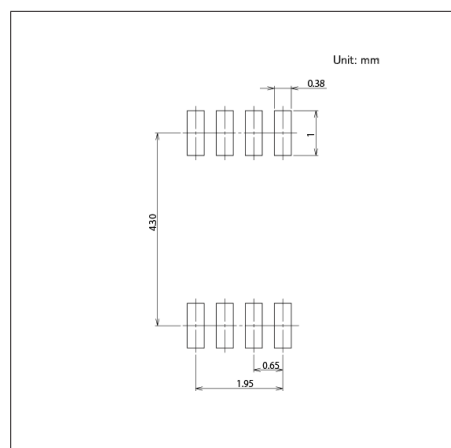

Analog Linear Output Type
HGAR Series

Drawing No.2

■ Dimensions

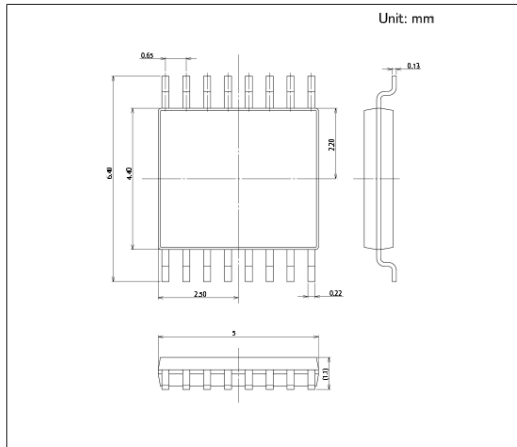

■ Land Dimensions

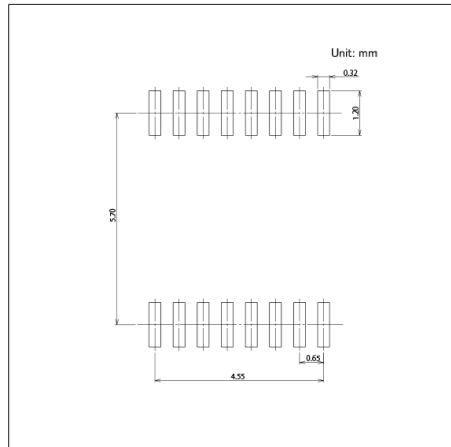

Drawing No.3

■ Dimensions

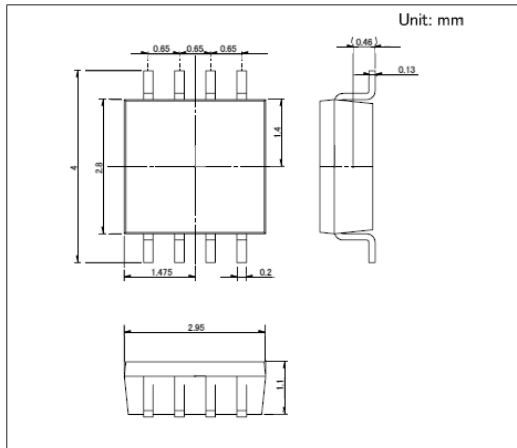

Drawing No.4

■ Dimensions

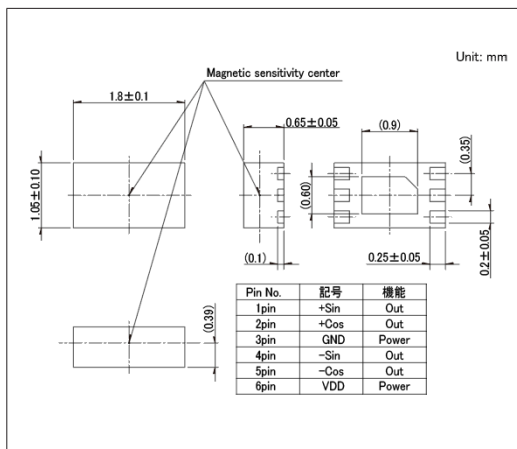

Sensors Magnetic Sensors

Switching Output Type
HGDVST Series

Magnetic switch with wide operating voltage range and compact package.



■ Type: Switching (Surface mount)

Applications: Game: Virtual/augmented reality
 Healthcare: Healthcare equipment, Nursing care equipment, Analysis, test equipment
 Home: Major home appliances
 Audio_TV: Visual, Audio, Pro audio, Cameras
 Automotive: Shifter, Navigation/audio systems, HVAC

■ Product List

Products No.	Package specifications	Function	Operating magnetic field	Drive voltage	Current consumption	Size (mm)	Automotive	Drawing No.
HGDVST022A	SOT23 type	Single polarity/Single output	Hon typ. 2.0mT Hoff typ. 1.4mT	3 to 30V	2.5mA Max. (at VDD=12V)	2.9×2.8×1.1	●	1

⚠ Note

1. This catalog shows only outline specifications. When using the products, please obtain formal specifications for supply.
2. Place your purchase order in N minimum package units (N: integer).

■ Packing Specifications

Taping

Number of packages (pcs.)			Tape width (mm)	Export package measurements (mm)
1 reel	1 case / Japan	1 case / export packing		
3,000	3,000	3,000	8	210 x 210 x 230

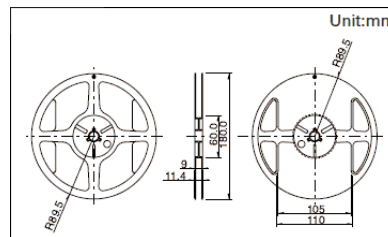

Drawing No. 1

■ Dimensions

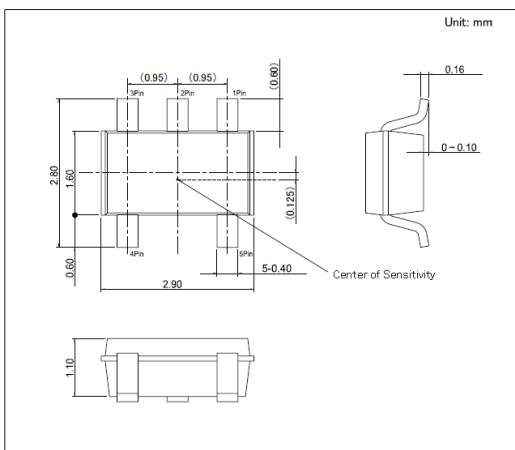

■ Land Dimensions

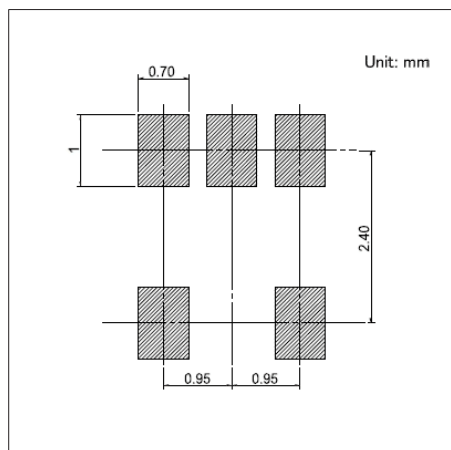

Sensors Magnetic Sensors

Incremental Encode Output Type
HGPRDT Series

Incorporates dual-phase output in a small package, contributing to miniaturization and design flexibility of encoder systems.

Automotive

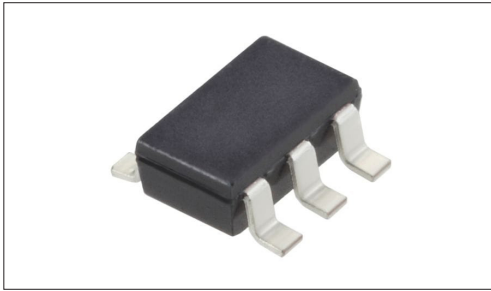

■ Type:Encoder (Surface mount)

Applications:Automotive:Navigation/audio systems, HVAC,Tailgate, Power Windows,Steering

■ Product List

Products No.	Package specifications	Function	Operating magnetic field	Drive voltage	Current consumption	Size (mm)	Automotive	Drawing No.
HGPRDT006A	SOT23 type	Alternating output/ Direction of rotation output	Hon: +0.8mT Typ Hoff: -0.8mT Typ	12V Typ. (3 to 30V)	1.6mA Typ. (at VDD=12V)	2.9×2.8×1.1	●	1
HGPRDT007A	SOT23 type	2-phase alternating output	Hon: +0.8mT Typ Hoff: -0.8mT Typ	12V Typ. (3 to 30V)	1.6mA Typ. (at VDD=12V)	2.9×2.8×1.1	●	

Note

1. This catalog shows only outline specifications. When using the products, please obtain formal specifications for supply.
2. Place your purchase order in N minimum package units (N: integer).

■ Packing Specifications

Taping

Number of packages (pcs.)			Tape width (mm)	Export package measurements (mm)
1 reel	1 case / Japan	1 case / export packing		
3,000	3,000	45,000	8	210 x 210 x 230

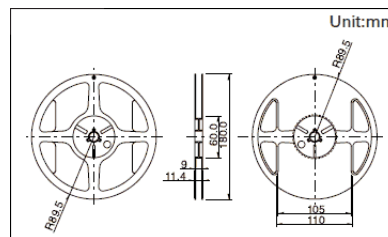

Drawing No.1

■ Dimensions

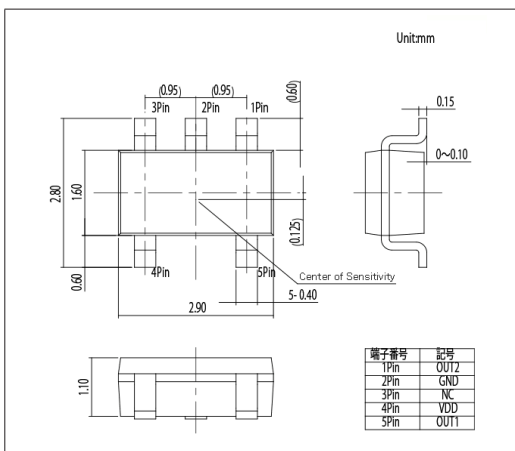

■ Land Dimensions

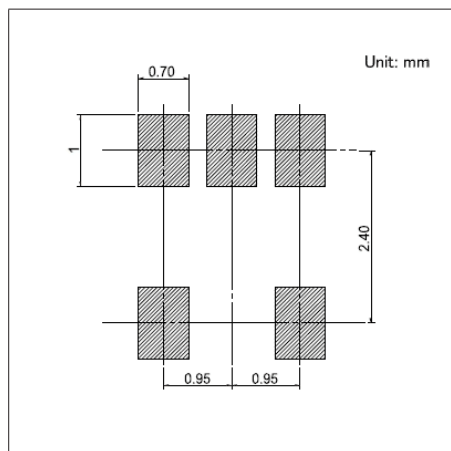

Geomagnetic Sensors

List of Varieties

Series		HSCD
Photo		
Type		Electric compass
Dimensions (mm)		1.6×1.6×0.65 8pin LGA
Operating voltage	AVDD: Drive voltage	+1.7 to +3.6V
	DVDD_io: Drive voltage	+1.65 to AVDD
Operating magnetic field		±2.4mT
Current consumption		3μA typ. (standby) 60μA typ. (active)
Operating temperature range		-40°C to +85°C
Interface		I ² C
Automotive		—

Geomagnetic Type HSCD Series

High azimuth accuracy and low current consumption.

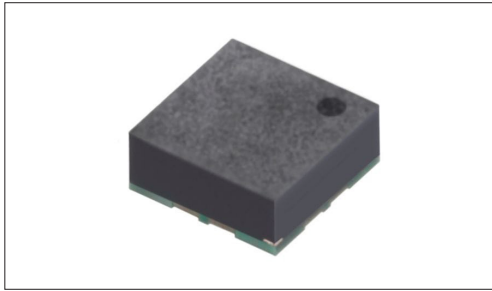

■ Type: Electric compass

Applications: Mobile: Smartphones, tablets, Headsets, wearables
 Energy_Industrial: Robots, drones, Industrial equipment, Converters
 Game: Home handheld consoles, Virtual/augmented reality
 Healthcare: Healthcare equipment, Nursing care equipment, Analysis, test equipment
 Audio_TV: Visual, Audio, Pro audio, Cameras

■ Product List

Products No.	Measurement range	Interface	Operating voltage		Current consumption	Size (mm)	Automotive	Drawing No.
			AVDD: Drive voltage	DVDD_io: Drive voltage				
HSCDTD008A	±2.4mT	I ² C	+1.7 to +3.6V	+1.65 to AVDD	60μA typ. (active) 3μA typ. (standby)	1.6×1.6×0.65 8pin LGA	—	1

Note

1. This catalog shows only outline specifications. When using the products, please obtain formal specifications for supply.
2. Place your purchase order in N minimum package units (N: integer).
3. Azimuth accuracy (margin of error) may be influenced by environmental conditions and other devices.

■ Packing Specifications

Taping

Number of packages (pcs.)			Tape width (mm)	Export package measurements (mm)
1 reel	1 case / Japan	1 case / export packing		
3,000	3,000	45,000	8	210×210×230

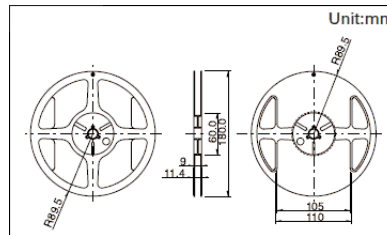

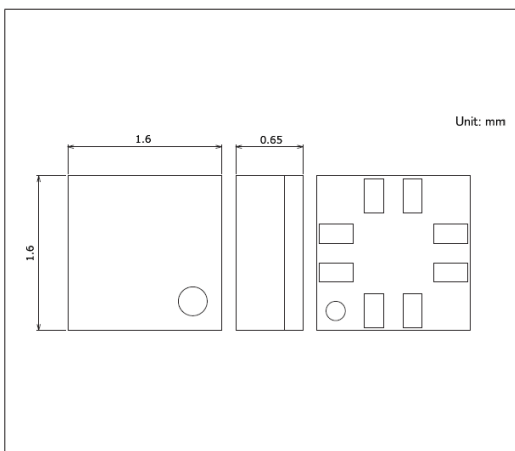

Drawing No. 1

■ Dimensions



Humidity Sensors

List of Varieties

Series	HSHCA (SMD)	HSHCA (Connector)
Photo		
Type	Surface mount	Connector pre-mounted on PCB
Mounting method	Surface mount	Connector
Dimensions (mm)	2.0×2.0×0.88 2.5×2.2×1.0	24.0×16.0 30.0×13.0
Humidity range	0 to 100%RH	
Operating temperature range	-10°C to +85°C -20°C to +85°C	-20°C to +60°C -20°C to +85°C -25°C to +85°C
Supply voltage	1.8V ±5% 2.2 to +3.6V	2.15 to 5.5V 2.5 to 5.5V 4.75 to 5.25V
Automotive	—	—

Sensors Humidity Sensors

Humidity Sensor HSHCA (SMD) Series

Accurately detects humidity up to 100% in a compact package.



■ Type: Surface mount

Applications: Mobile: Smartphones, tablets, Headsets, wearables
 Game: Virtual/augmented reality
 Healthcare: Healthcare equipment, Nursing care equipment, Analysis, test equipment
 Home: Major home appliances, Office equipment

■ Product List

Products No.	Features	Humidity range	Operating temperature	Supply voltage	Size (mm)	Automotive	Drawing No.
HSHCAA006A	Humidity sensor with analog output	0 to 100%RH	-10°C to +85°C	2.2 to +3.6V	2.5×2.2×1.0	—	1
HSHCAL001B	I ² C digital output and temperature measurement function	0 to 100%RH	-20°C to +85°C	1.8V ±5%	2.0×2.0×0.88	—	2

Note

1. This catalog shows only outline specifications. When using the products, please obtain formal specifications for supply.
2. Please place purchase orders per minimum order unit (integer).

■ Packing Specifications

Taping

Number of packages (pcs.)			Tape width (mm)	Export package measurements (mm)
1 reel	1 case / Japan	1 case / export packing		
3,000	3,000	45,000	8	210×210×230

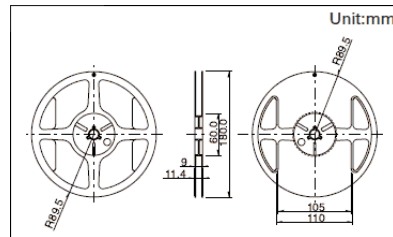

Drawing No.1

■ Dimensions

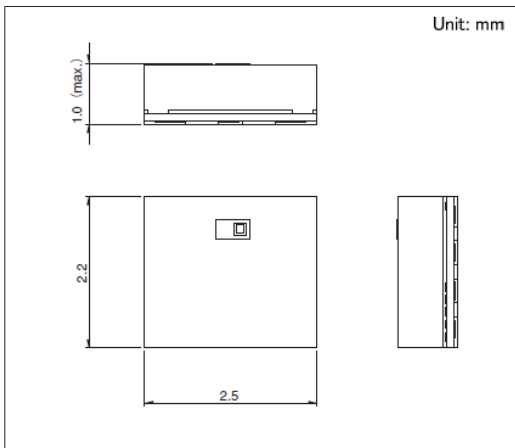

Humidity Sensor
HSHCA (SMD) Series

Drawing No.2

■ Dimensions

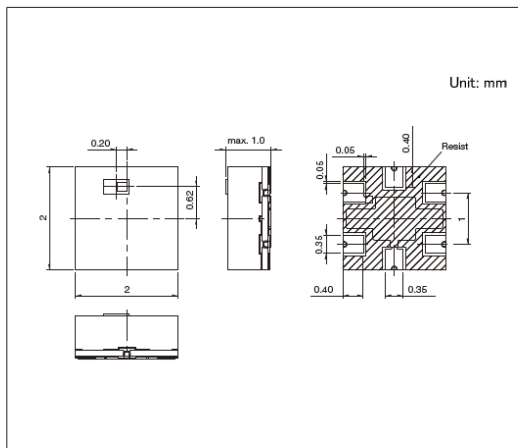

Sensors Humidity Sensors

Humidity Sensor HSHCA (Connector) Series

Connector-type design equipped with a compact humidity sensor, easy to use in various locations.

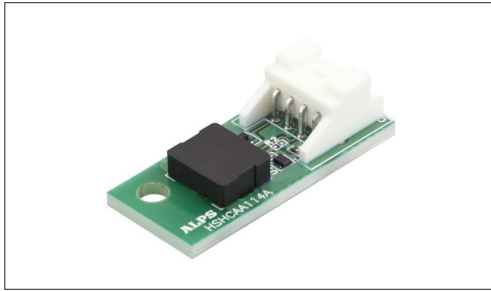

■ Type: Connector pre-mounted on PCB

Applications: Game: Virtual/augmented reality
 Healthcare: Healthcare equipment, Nursing care equipment,
 Analysis, test equipment
 Home: Major home appliances, Office equipment
 Energy_Industrial: Industrial equipment

■ Product List

Products No.	Features	Humidity range	Operating temperature	Supply voltage	Size (mm)	Automotive	Drawing No.
HSHCAA114A	With moisture-resistant coating	0 to 100%RH	-20°C to +60°C	4.75 to 5.25V	30.0×13.0	—	1
HSHCAL101B	I ² C digital output and temperature measurement function	0 to 100%RH	-20°C to +85°C	2.5 to 5.5V	24.0×16.0	—	2
HSHCAD140A	I ² C digital output and temperature measurement function	0 to 100%RH	-25°C to +85°C	2.15 to 5.5V	24.0×16.0	—	3

⚠ Note

1. This catalog shows only outline specifications. When using the products, please obtain formal specifications for supply.
2. Please place purchase orders per minimum order unit (integer).

■ Packing Specifications

Tray

Products No.	Number of packages(pcs.)		Export package measurements (mm)
	1 case / Japan	1 case / export packing	
HSHCAA114A	1,000	1,000	360×240×307
HSHCAL101B HSHCAD140A	1,000	1,000	360×240×252

Drawing No. 1

■ Dimensions

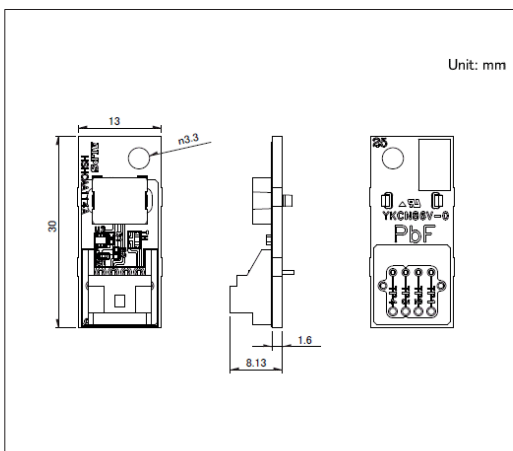

Humidity Sensor HSHCA (Connector) Series

Drawing No.2

■ Dimensions

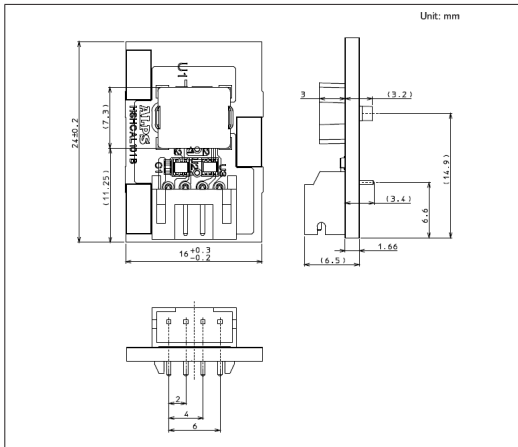

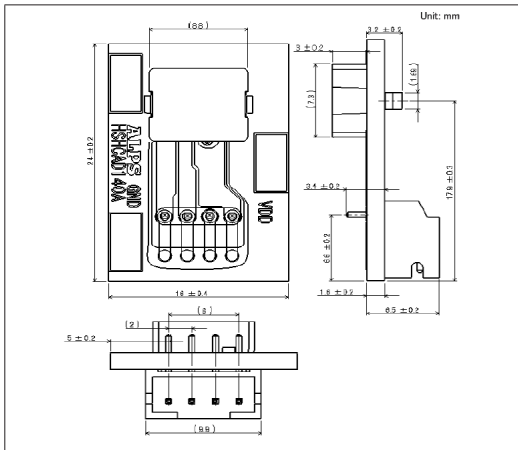

Drawing No.3

■ Dimensions



Pressure Sensors

List of Varieties

Series	HSPPAR	HSPPAD (Water-proof)	HSFPAR
Photo			
Type	Atmospheric pressure detection	Atmospheric pressure detection, Depth of water detection	Load detection
Water-proof	—	●	—
Mounting method	Surface mount		
Dimensions (mm)	2.5×2.5×0.7	3.1×3.1×2.6	1.5×0.85×0.68 2.0×1.6×0.66
Interface	Differential voltage	I ² C	—
Operating temperature range	-20°C to +85°C	-40°C to +85°C	
Supply voltage	—	1.7 to 3.6V	1.5 to 3.6V
Automotive	—	—	—

 **Note**

● Indicates applicability to all products in the series, while ○ indicates applicability to some products in the series.

Sensors Pressure Sensors

MEMS Pressure Sensor
HSPPAR Series

Compact type expanding application possibilities.

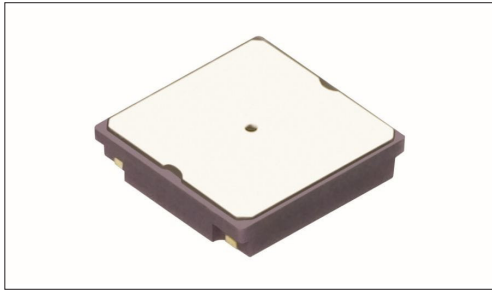

- Type: Atmospheric pressure detection
- Mounting method: Surface mount

Applications: Mobile: Smartphones, tablets, Headsets, wearables, Notebooks, peripherals
 Energy_Industrial: Robots, drones, Industrial equipment, Converters
 Game: Virtual/augmented reality
 Healthcare: Healthcare equipment, Nursing care equipment, Analysis, test equipment
 Home: Major home appliances

■ Product List

Products No.	Function	Features	Interface	Pressure measurement range	Operating temperature range	Size (mm)	Automotive	Drawing No.
HSPPAR003D	Atmospheric pressure detection	Pressure sensor element contained within housing	Differential voltage	500 to 1100hPa	-20°C to +85°C	2.5×2.5×0.7	—	1

⚠ Note

1. This catalog shows only outline specifications. When using the products, please obtain formal specifications for supply.
2. Place your purchase order in N minimum package units (N: integer).

■ Packing Specifications

Taping

Number of packages (pcs.)			Tape width (mm)	Export package measurements (mm)
1 reel	1 case / Japan	1 case / export packing		
3,000	3,000	45,000	8	210×210×230

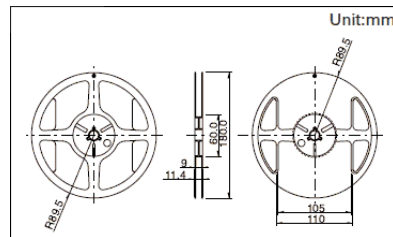

Drawing No.1

■ Dimensions

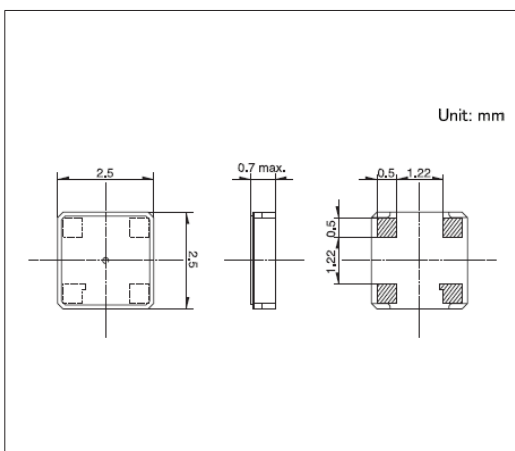

MEMS Pressure Sensor HSPPAD (Water-proof Type) Series

Water-proof piezoresistive design, suitable for water depth detection.

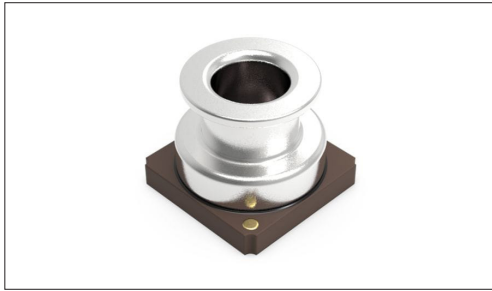

- Type: Atmospheric pressure detection, Depth of water detection
- Mounting method: Surface mount

Applications: Infrastructure: Smart meters
 Healthcare: Healthcare equipment, Nursing care equipment,
 Analysis, test equipment
 Mobile: Headsets, wearables

■ Product List

Products No.	Function	Features	Interface	Pressure measurement range	Operating temperature range	Size (mm)	Automotive	Drawing No.
HSPPAD143C	Atmospheric pressure detection, Depth of water detection (Water-proof)	Water-proof pressure sensor, output range 300 to 2000hPa	I ² C	300 to 2000hPa	-40°C to +85°C	3.1×3.1×2.6	—	1
HSPPAD147A	Atmospheric pressure detection, Depth of water detection (Water-proof)	Water-proof pressure sensor, output range 30 to 750kPa	I ² C	30 to 750kPa	-40°C to +85°C	3.1×3.1×2.6	—	
HSPPAD148A	Atmospheric pressure detection, Depth of water detection (Water-proof)	Water-proof pressure sensor, output range 30 to 3200kPa	I ² C	30 to 3200kPa	-40°C to +85°C	3.1×3.1×2.6	—	

Note

1. This catalog shows only outline specifications. When using the products, please obtain formal specifications for supply.
2. Place your purchase order in N minimum package units (N: integer).

■ Packing Specifications

Taping

Number of packages (pcs.)			Tape width (mm)	Export package measurements (mm)
1 reel	1 case / Japan	1 case / export packing		
500	500	5,000	12	210×210×230

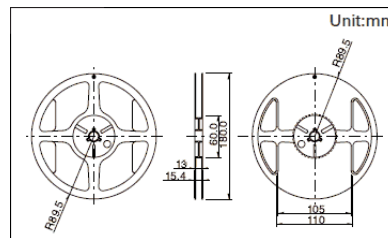

Drawing No.1

■ Dimensions

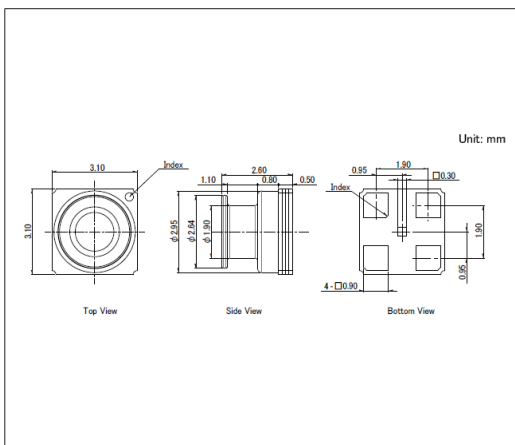

Force Sensor HSFPAR Series

High-sensitivity load detection in a compact package.



- Type: Load detection
- Mounting method: Surface mount

Applications: Mobile: Smartphones, tablets, Headsets, wearables,
Notebooks, peripherals
Game: Virtual/augmented reality
Healthcare: Healthcare equipment, Nursing care equipment,
Analysis, test equipment

■ Product List

Products No.	Function	Features	Force range	Operating temperature range	Supply voltage	Size (mm)	Automotive	Drawing No.
HSFPAR004A	Load detection	High-sensitivity load detection with a compact package	0 to 8N	-40°C to +85°C	1.5 to 3.6V	2.0×1.6×0.66	—	1
HSFPAR007A	Load detection	High-sensitivity load detection with a compact package	0 to 8N	-40°C to +85°C	1.5 to 3.6V	1.5×0.85×0.68	—	2

Note

1. This catalog shows only outline specifications. When using the products, please obtain formal specifications for supply.
2. Please place purchase orders for taping products per minimum order unit (1 reel or a case).

■ Packing Specifications

Taping

Number of packages (pcs.)			Tape width (mm)	Export package measurements (mm)
1 reel	1 case / Japan	1 case / export packing		
3,000	3,000	45,000	8	210×210×230

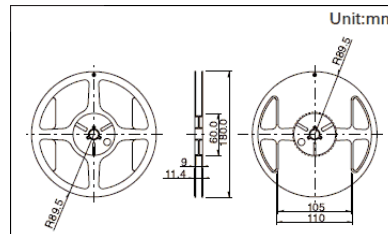

Drawing No. 1

■ Dimensions

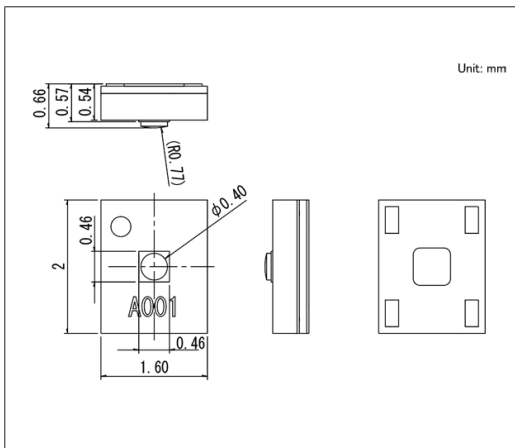

Force Sensor
HSFPAR Series



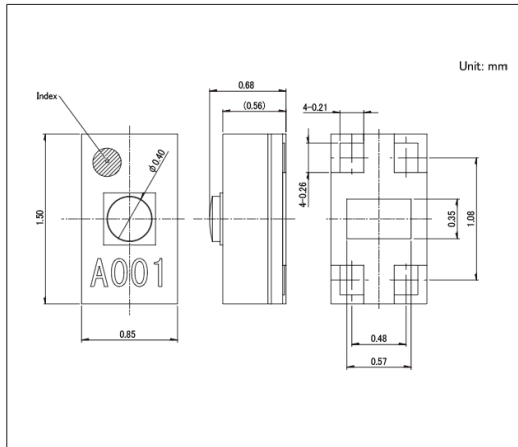

Drawing No.2

■ Dimensions



Resistive Position Sensors

List of Varieties

Series		RDC50	RDC90	RD6R1A	RDC10	RD7
Photo						
Control part orientation		Horizontal Vertical	Vertical	—	Vertical	Horizontal Vertical
Type		Rotary			Linear	
Terminal style		Insertion Reflow	Reflow	Connector terminal	Insertion	
Dimensions (mm)		11.0×3.9×13.5 11.0×12.0×2.2 11.0×12.0×2.75 11.0×12.0×3.5	11.0×13.7×3.2	20.6×32.5×3.6	6.5×17.3×2.1 6.9×23.5×2.9 6.9×31.5×2.9 6.9×41.5×2.9 6.9×56.5×3.0 6.9×96.7×3.45	9.0×15.8×3.7 10.0×5.0×15 10.0×5.0×19.0 10.0×15.0×4.5 10.0×18.0×5.0
Total resistance		4.7kΩ 10kΩ	3.3kΩ 10kΩ	3.8kΩ	10kΩ	2.2kΩ 4.7kΩ 5kΩ 10kΩ
Effective electrical range		150° 333.3°	80° 260°	320°	—	
Linearity guarantee range		140° 320°	60° 244°	310°	9.2mm 12mm 20mm 30mm 45mm 85mm	6mm 7mm 9mm
Linearity		±2%	±3%	±2%	±0.5% ±1%	±1%
Operating force		—			0.25N max.	2N max.
Rotational torque		2mN·m max.		100mN·m	—	
Electrical performance	Total resistance tolerance	±30%		±20%	±30%	±20%
	Rated voltage	5V DC				—
Environmental test	Cold	-40°C 168h			-40°C 240h	-40°C 96h
	Dry heat	120°C 168h		85°C 168h	80°C 240h 85°C 240h 90°C 240h	105°C 96h
	Damp heat	60°C, 90 to 95%RH 96h		80°C, 90 to 95%RH 96h	60°C, 90 to 95%RH 240h	40°C, 90 to 95%RH 96h
Automotive		●	●	●	○	●

 Note

● Indicates applicability to all products in the series, while ○ indicates applicability to some products in the series.

Rotary Type RDC50 Series

Compact, high-precision, and high-heat-resistant design, suitable for all position detection needs.

 Automotive

■ Type: Rotary

Applications: Energy_Industrial: Robots, drones, Industrial equipment
 Healthcare: Healthcare equipment, Nursing care equipment
 Analysis, test equipment: Analysis, test equipment
 Home: Major home appliances, Office equipment
 Audio_TV: Visual, Audio
 Automotive: Navigation/audio systems, HVAC

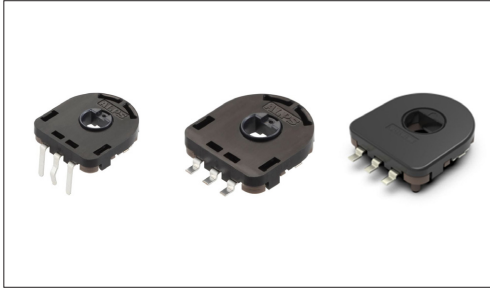

■ Product List

Products No.	Control part orientation	Mounting method	Linearity guarantee range	Linearity	Total resistance	Operating life (cycles)	Dimensions (mm)	Automotive	Drawing No.
RDC501051A	Vertical	Manual, DIP	320°	±2%	10kΩ	1,000,000	11.0×12.0×3.5	●	1
RDC501052A	Vertical	Manual, DIP	320°	±2%	10kΩ	1,000,000	11.0×12.0×3.5	●	2
RDC502012A	Horizontal	Manual, DIP	320°	±2%	10kΩ	1,000,000	11.0×3.9×13.5	●	3
RDC503051A	Vertical	Reflow	320°	±2%	10kΩ	1,000,000	11.0×12.0×2.75	●	4
RDC503052A	Vertical	Reflow	320°	±2%	10kΩ	1,000,000	11.0×12.0×2.75	●	5
RDC503051A	Vertical	Reflow	140°	±2%	4.7kΩ	1,000,000	11.0×12.0×2.75	●	4
RDC506018A	Vertical	Reflow (Low-profile)	320°	±2%	10kΩ	1,000,000	11.0×12.0×2.2	●	6
RDC506A03A	Vertical	Reflow (Low-profile, Long-life, Without case hole)	320°	±2%	10kΩ	2,000,000	11.0×12.0×2.2	●	7

⚠ Note

1. This catalog shows only outline specifications. When using the products, please obtain formal specifications for supply.
2. Please place purchase orders per minimum order unit (integer).

■ Packing Specifications

Tray

Products No.	Number of packages(pcs.)		Export package measurements (mm)
	1 case / Japan	1 case / export packing	
RDC501051A RDC501052A	1,500	3,000	526×370×191
RDC502012A	1,600	1,600	370×280×92

Taping

Products No.	Number of packages(pcs.)			Tape width (mm)	Export package measurements (mm)
	1 reel	1 case / Japan	1 case / export packing		
RDC503051A RDC503052A RDC503051A	1,300	3,900	3,900	24	415×407×135
RDC506018A RDC506A03A	1,200	3,600	3,600	24	415×407×135

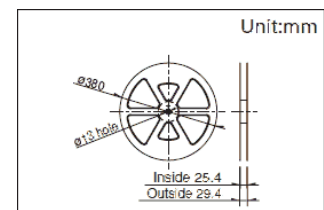

Rotary Type
RDC50 Series

Drawing No.1

■ Dimensions

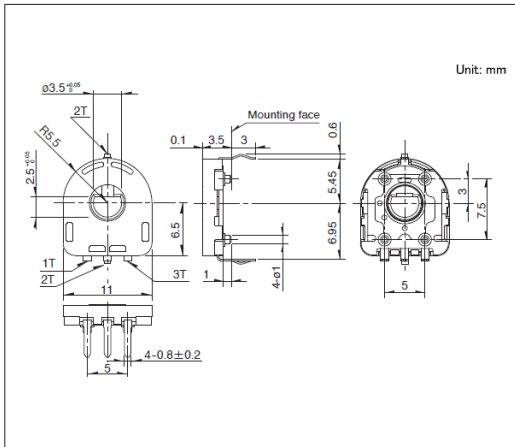

■ Mounting Hole Dimensions

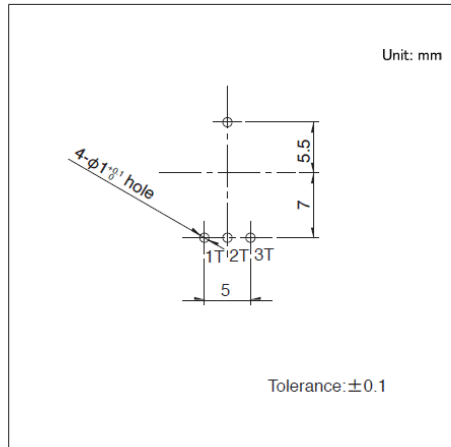

■ Circuit Diagram

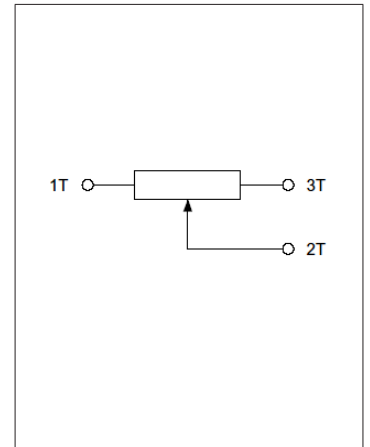

Viewed from mounting side

Drawing No.2

■ Dimensions

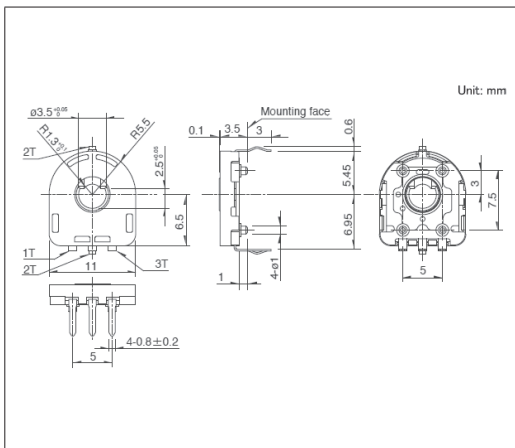

■ Mounting Hole Dimensions

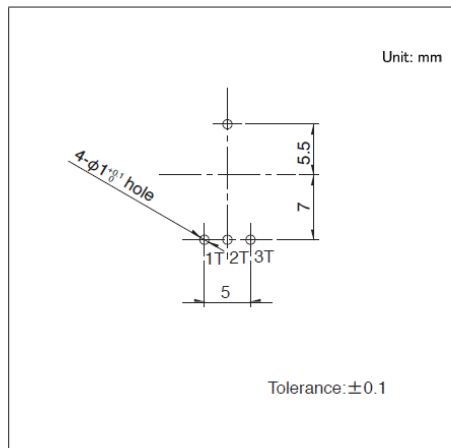

■ Circuit Diagram

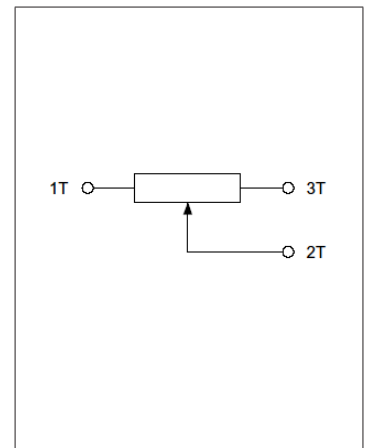

Viewed from mounting side

Drawing No.3

■ Dimensions

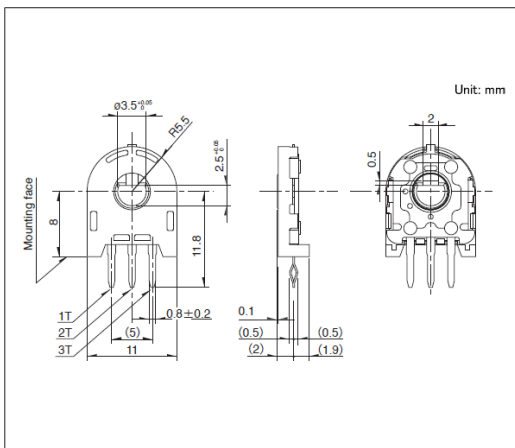

■ Mounting Hole Dimensions

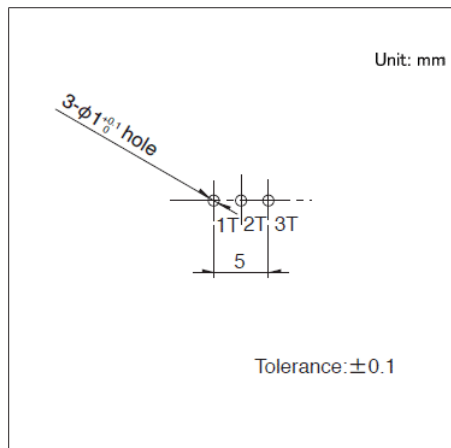

■ Circuit Diagram

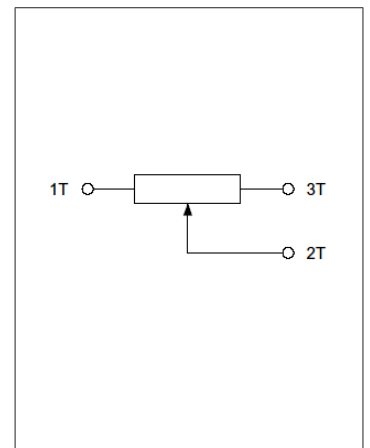

Viewed from mounting side

Sensors Resistive Position Sensors
Rotary Type
RDC50 Series

Drawing No.4

■ Dimensions

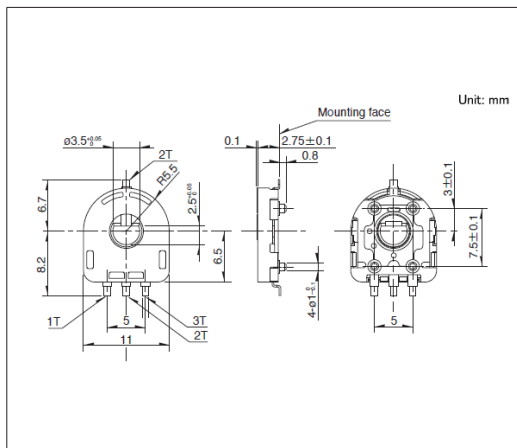

■ Mounting Hole Dimensions

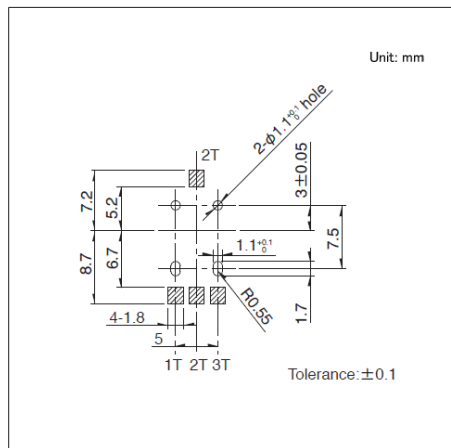

■ Circuit Diagram

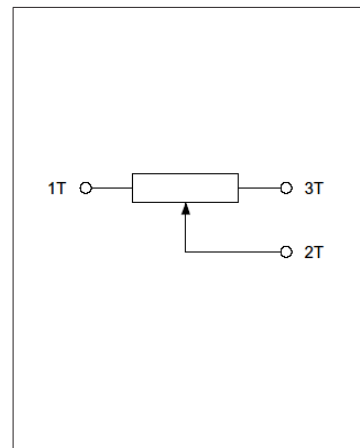

Viewed from mounting side

Drawing No.5

■ Dimensions

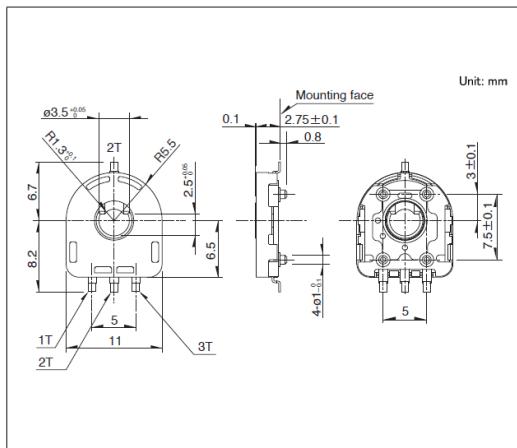

■ Mounting Hole Dimensions

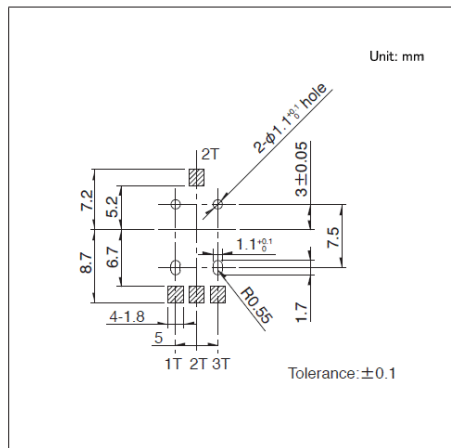

■ Circuit Diagram

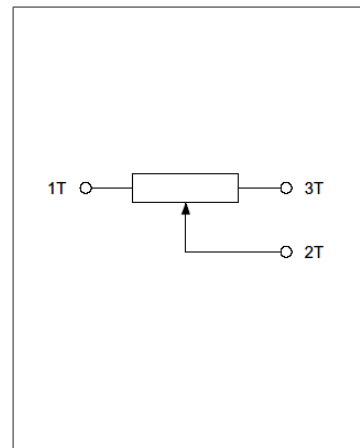

Viewed from mounting side

Drawing No.6

■ Dimensions

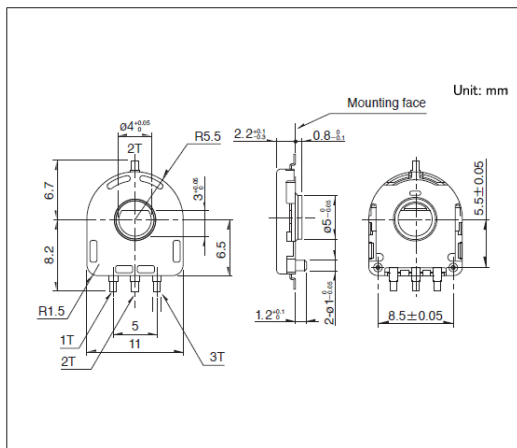

■ Land Dimensions

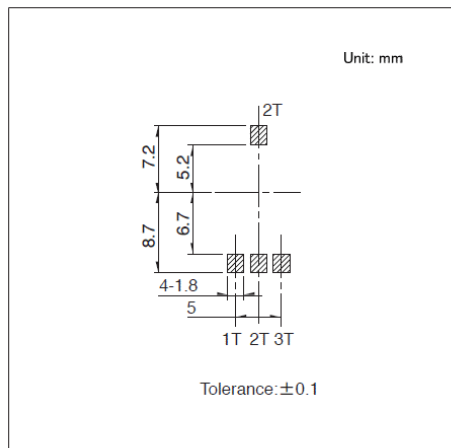

■ Circuit Diagram

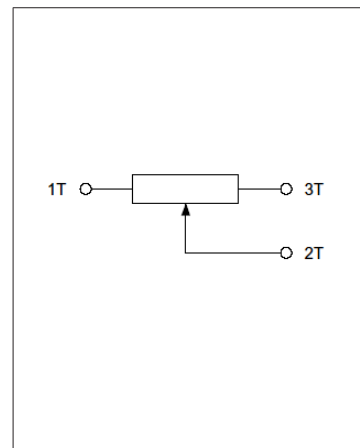

Viewed from mounting side

Rotary Type
RDC50 Series

Drawing No.7

■ Dimensions

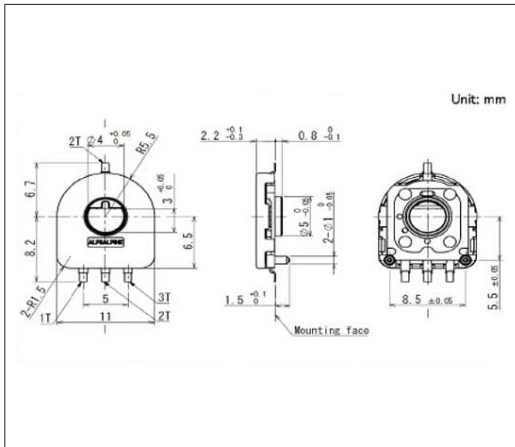

■ Land Dimensions

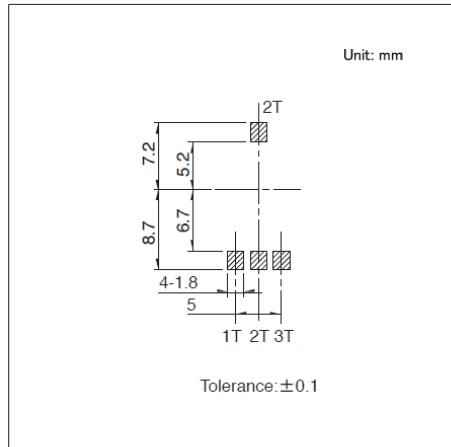

■ Circuit Diagram

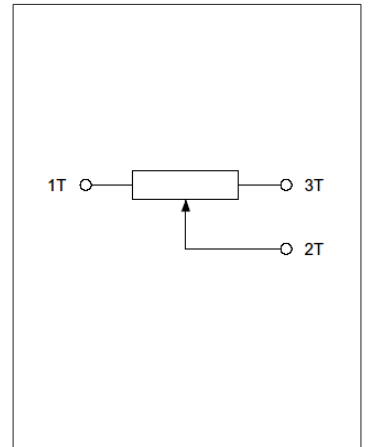

Viewed from mounting side

Compact Long-life Rotary Type RDC90 Series

10 million operation cycles in a compact design.

Automotive



■ Type: Rotary

Applications: Energy_Industrial: Robots, drones, Industrial equipment
Home: Major home appliances, Office equipment
Navigation/audio systems, HVAC: Navigation/audio systems, HVAC

■ Product List

Products No.	Control part orientation	Mounting method	Linearity guarantee range	Linearity	Total resistance	Operating life (cycles)	Dimensions (mm)	Automotive	Drawing No.
RDC9010006	Vertical	Reflow (Long-life)	60°	±3%	3.3kΩ	10,000,000	11.0×13.7×3.2	●	1
RDC9010007	Vertical	Reflow (Long-life)	244°	±3%	10kΩ	10,000,000	11.0×13.7×3.2	●	

Note

1. This catalog shows only outline specifications. When using the products, please obtain formal specifications for supply.
2. Please place purchase orders per minimum order unit (integer).

■ Packing Specifications

Tray

Number of packages (pcs.)		Export package measurements (mm)
1 case / Japan	1 case / export packing	
1,960	1,960	300×240×270

Drawing No. 1

■ Dimensions

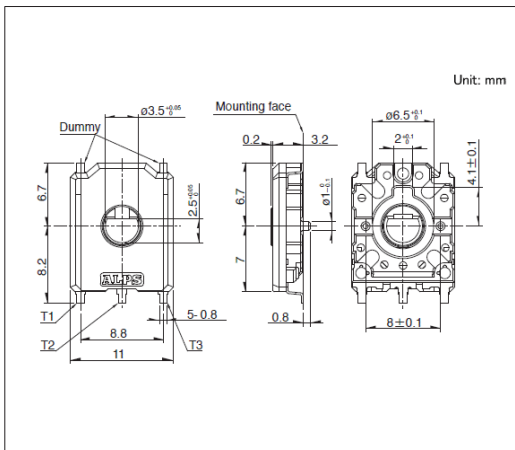

■ Mounting Hole Dimensions

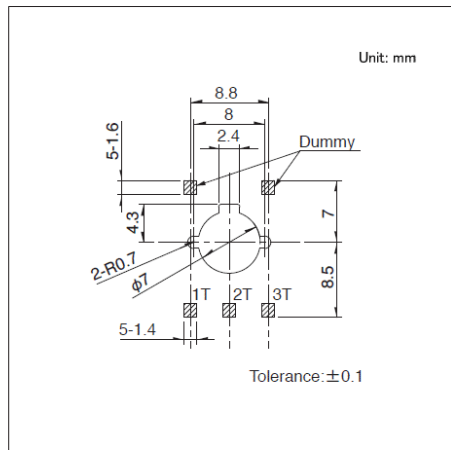

Viewed from mounting side

■ Circuit Diagram

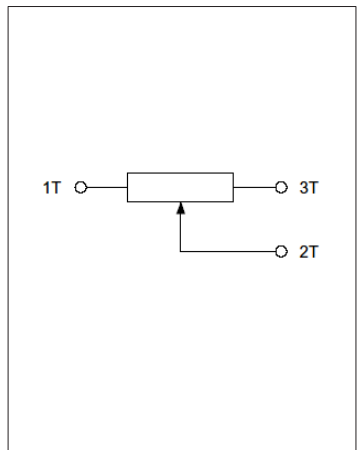

Rotary Type RD6R1A Series

Long-life sensor compliant with absolute linearity specifications.

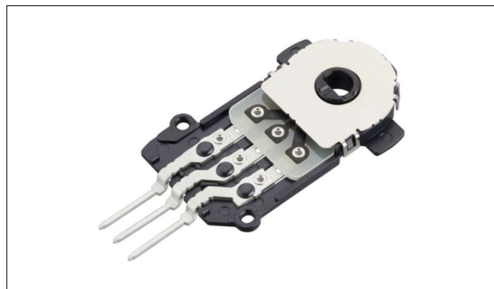

Automotive

■ Type: Rotary

Applications: Automotive: Navigation/audio systems, HVAC

Product List

Products No.	Mounting method	Linearity guarantee range	Linearity	Total resistance	Operating life (cycles)	Dimensions (mm)	Automotive	Drawing No.
RD6R1A0008	Connector type	310°	±2%	3.8kΩ	500,000	20.6×32.5×3.6		1

Note

1. This catalog shows only outline specifications. When using the products, please obtain formal specifications for supply.
2. Please place purchase orders per minimum order unit (integer).

Packing Specifications

Tray

Number of packages (pcs.)		Export package measurements (mm)
1 case / Japan	1 case / export packing	
1,800	1,800	540×360×250

Drawing No.1

Dimensions

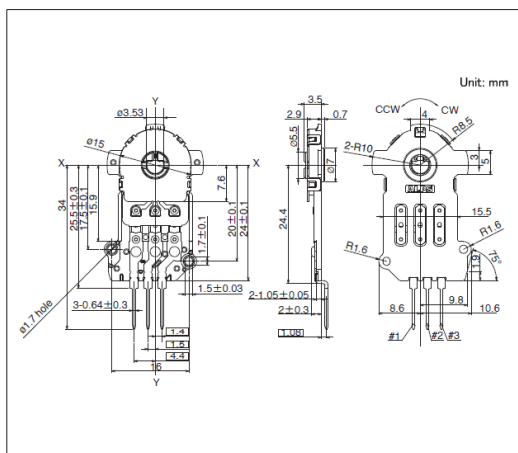

Circuit Diagram

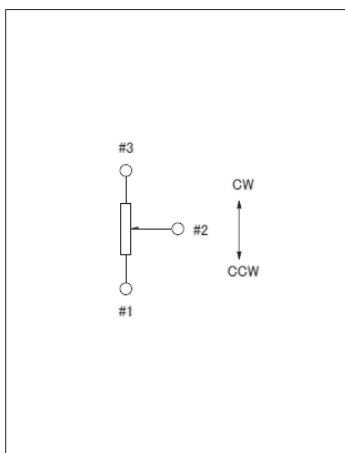

Linear Type RDC10 Series

High-precision ($\pm 0.5\%$ relative linearity) space-saving design, contributing to set miniaturization.



 Automotive

※Please check the product list for compatible products

■ Type: Linear

Applications: Energy_Industrial: Robots, drones
 Game: Home handheld consoles, Virtual/augmented reality
 Healthcare: Healthcare equipment, Analysis, test equipment
 Nursing care equipment: Nursing care equipment
 Home: Major home appliances, Office equipment
 Automotive: Navigation/audio systems, HVAC

■ Product List

Products No.	Control part orientation	Travel (mm)	Linearity guarantee range	Linearity	Total resistance	Operating life (cycles)	Dimensions (mm)	Automotive	Drawing No.
RDC1010A12	Vertical	10	9.2mm	$\pm 0.5\%$	10k Ω	50,000	6.5×17.3×2.1	—	1
RDC1014A09	Vertical	14	12mm	$\pm 0.5\%$	10k Ω	200,000	6.9×23.5×2.9	●	2
RDC1022A05	Vertical	22	20mm	$\pm 0.5\%$	10k Ω	200,000	6.9×31.5×2.9	●	
RDC10320RB	Vertical	32	30mm	$\pm 0.5\%$	10k Ω	200,000	6.9×41.5×2.9	●	
RDC1047A03	Vertical	47	45mm	$\pm 0.5\%$	10k Ω	200,000	6.9×56.5×3.0	●	
RDC1087A01	Vertical	87	85mm	$\pm 1\%$	10k Ω	100,000	6.9×96.7×3.45	—	3

Note

1. This catalog shows only outline specifications. When using the products, please obtain formal specifications for supply.
2. Please place purchase orders per minimum order unit (integer).
3. RDC1014, RDC1022, RDC1032 and RDC1047 Series are available in different varieties to product line.

■ Packing Specifications

Tray

Products No.	Number of packages(pcs.)		Export package measurements (mm)
	1 case / Japan	1 case / export packing	
RDC1010A12	980	2,940	360×270×230
RDC1014A09	2,400	4,800	508×374×272
RDC1022A05	2,100	4,200	508×374×302
RDC10320RB	900	1,800	540×360×205
RDC1047A03	1,000	2,000	508×374×272
RDC1087A01	540	540	540×360×130

Linear Type
RDC10 Series

Drawing No.1

■ Dimensions

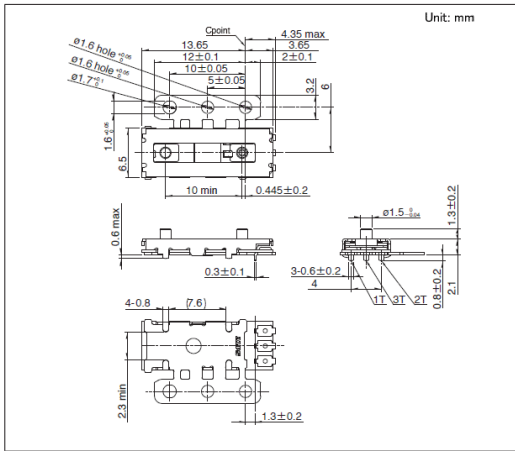

■ Mounting Hole Dimensions

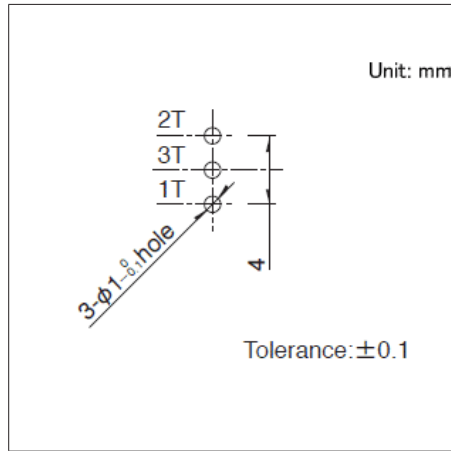

■ Circuit Diagram

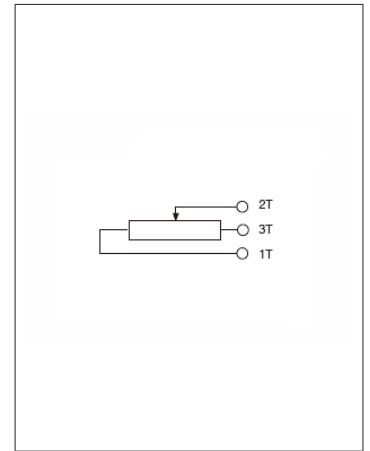

Drawing No.2

■ Dimensions

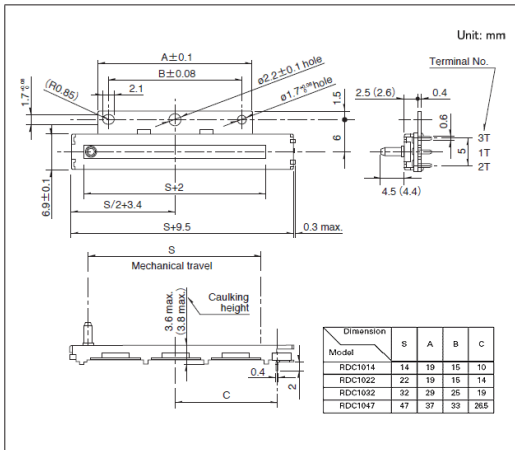

■ Mounting Hole Dimensions

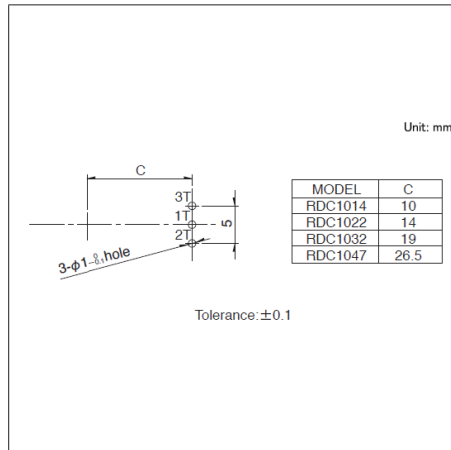

■ Circuit Diagram

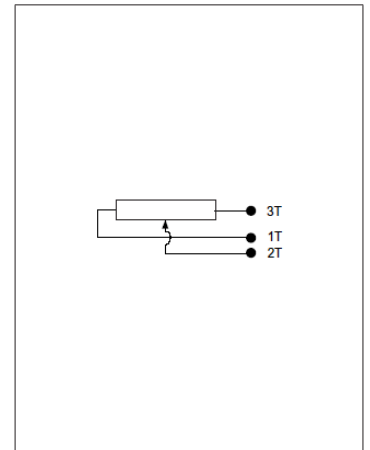

Drawing No.3

■ Dimensions

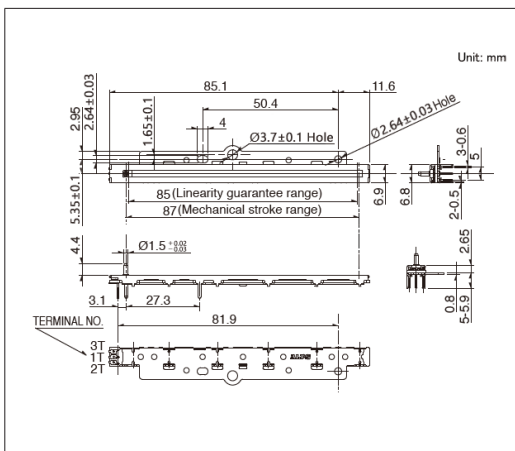

■ Mounting Hole Dimensions

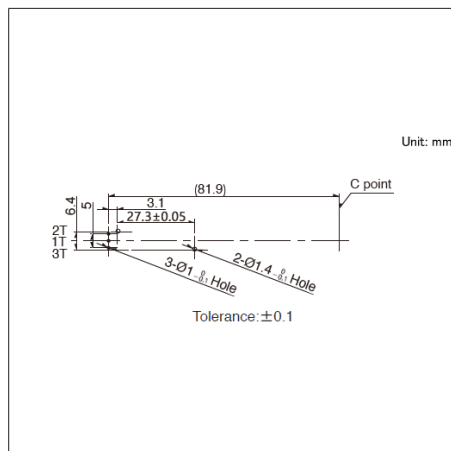

■ Circuit Diagram

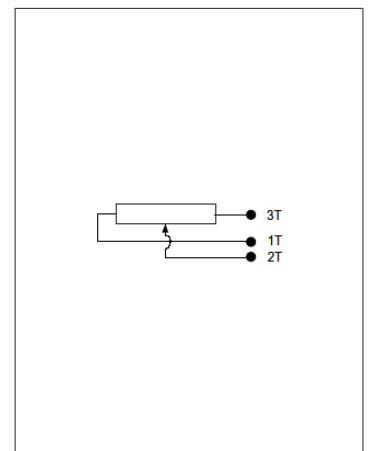

Linear Type (Exclusively Used to Detect the Angle of Vehicle Head Lights)

RD7 Series

High-precision, space-saving design dedicated to headlight angle detection.

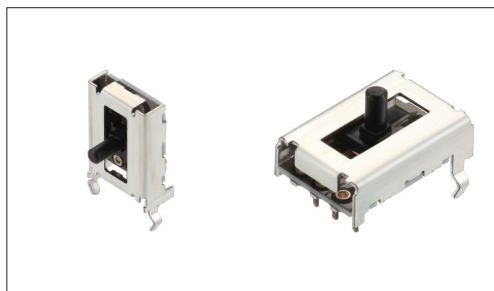
 Automotive

■ Type: Linear

Applications: Automotive: Headlights

■ Product List

Products No.	Control part orientation	Travel (mm)	Linearity guarantee range	Linearity	Total resistance	Operating life (cycles)	Dimensions (mm)	Automotive	Drawing No.
RD708A029A	Horizontal	8	6mm	±1%	4.7kΩ	100,000	10.0×5.0×15	●	1
RD7081015A	Vertical	8	7mm	±1%	5kΩ	100,000	10.0×15.0×4.5	●	2
RD7091008A	Vertical	9	7mm	±1%	5kΩ	100,000	9.0×15.8×3.7	●	3
RD712A028A	Horizontal	12	9mm	±1%	2.2kΩ	100,000	10.0×5.0×19.0	●	4
RD7121008A	Vertical	12	9mm	±1%	10kΩ	100,000	10.0×18.0×5.0	●	5

 Note

1. This catalog shows only outline specifications. When using the products, please obtain formal specifications for supply.
2. For Linearity, various specifications will be available, depending on the applications. Please consult with us when placing your orders.
3. Please place purchase orders per minimum order unit (integer).

■ Packing Specifications

Tray

Products No.	Number of packages(pcs.)		Export package measurements (mm)
	1 case / Japan	1 case / export packing	
RD708A029A RD712A028A	2,000	4,000	527×363×215
RD7081015A	1,500	3,000	507×363×216
RD7091008A	1,800	3,600	508×364×192
RD7121008A	1,800	3,600	507×363×216

Linear Type (Exclusively Used to Detect the Angle of Vehicle Head Lights)
RD7 Series

Drawing No.1

■ Dimensions

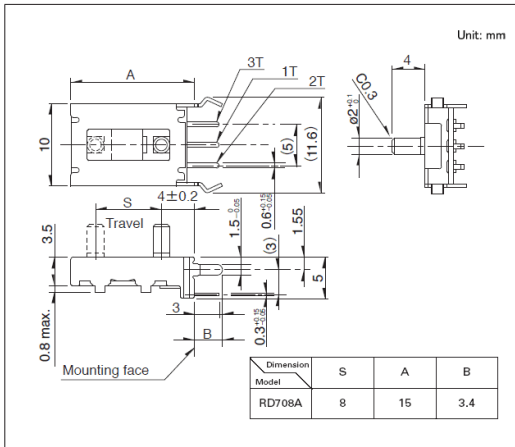

■ Mounting Hole Dimensions

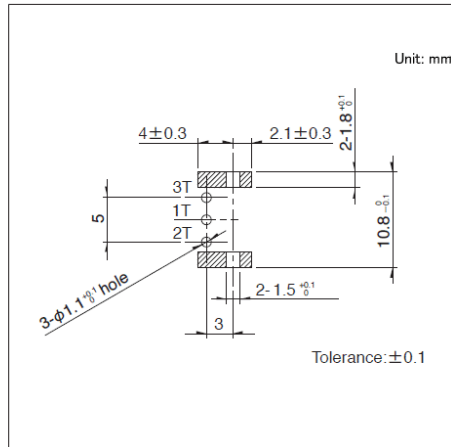

■ Circuit Diagram

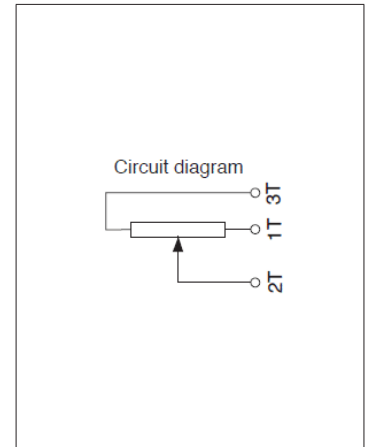

Viewed from mounting side
 Do not wire the shaded area

Drawing No.2

■ Dimensions

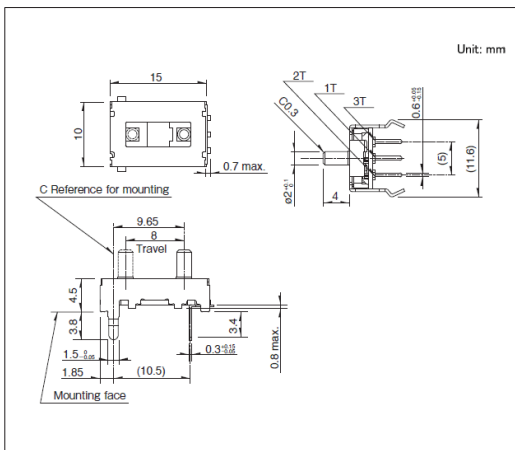

■ Mounting Hole Dimensions

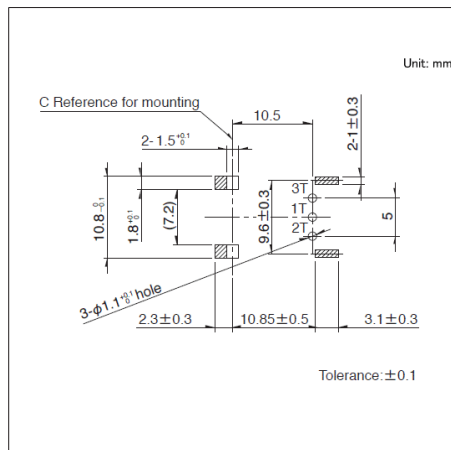

■ Circuit Diagram

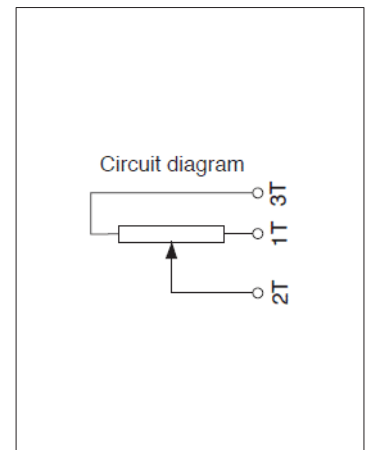

Viewed from mounting side
 Do not wire the shaded area

Drawing No.3

■ Dimensions

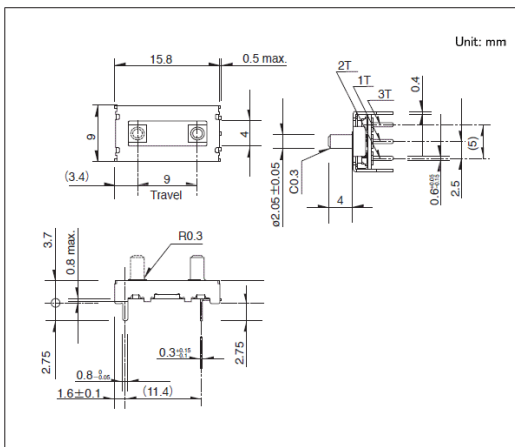

■ Mounting Hole Dimensions

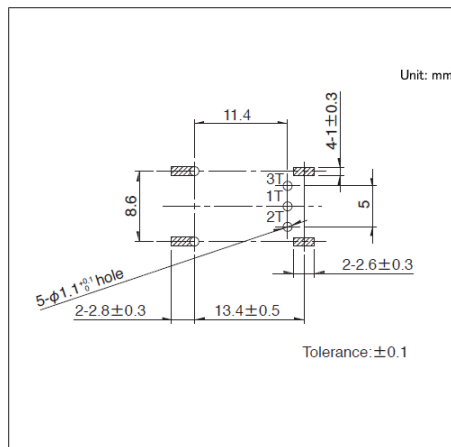

■ Circuit Diagram

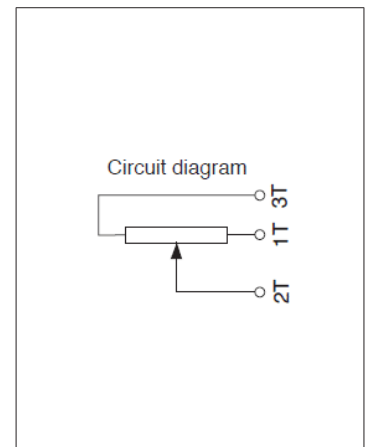

Viewed from mounting side
 Do not wire the shaded area

Linear Type (Exclusively Used to Detect the Angle of Vehicle Head Lights)
RD7 Series

Drawing No.4

■ Dimensions

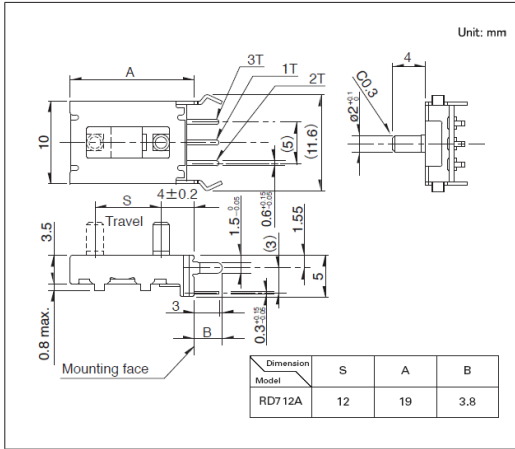

■ Mounting Hole Dimensions

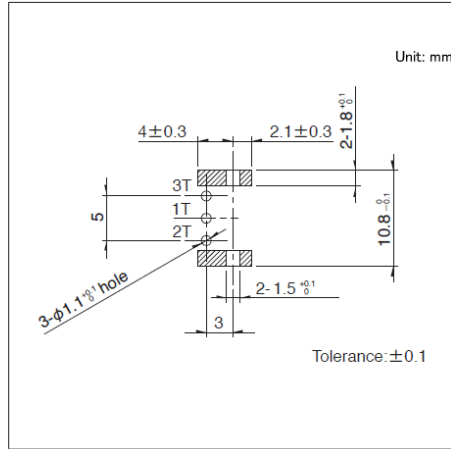

■ Circuit Diagram

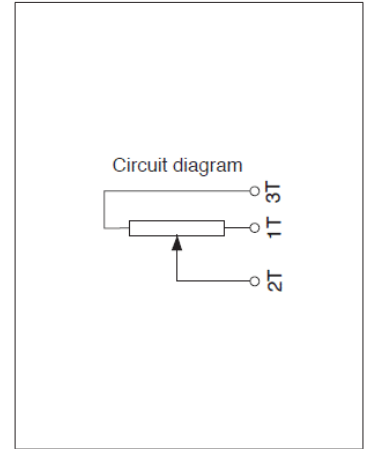

Viewed from mounting side
 Do not wire the shaded area

Drawing No.5

■ Dimensions

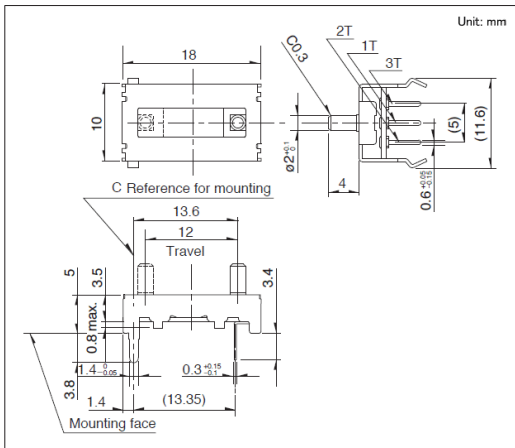

■ Mounting Hole Dimensions

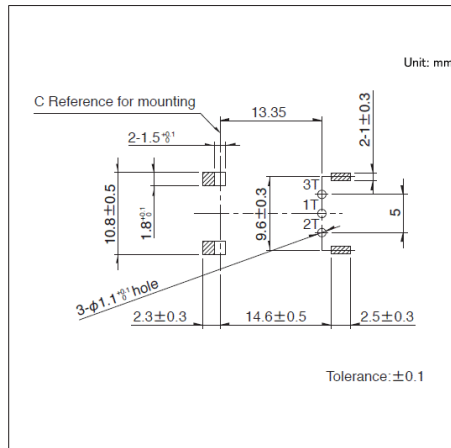

■ Circuit Diagram

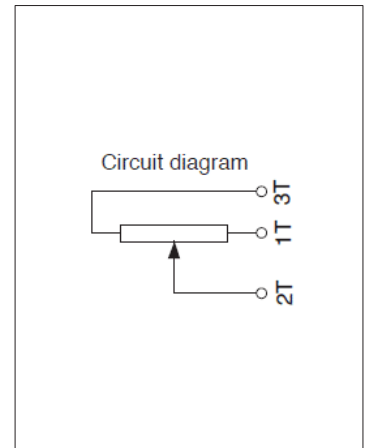

Viewed from mounting side
 Do not wire the shaded area

Resistive Position Sensors / Soldering Conditions

■ Reference for Manual Soldering

Series	Tip temperature	Soldering time
RDC50, RDC90	350±5°C	3 ⁺¹ ₀ s
RDC10, RD7	350°C max.	3s max.

■ Reference for Dip Soldering

Series	Preheating		Dip soldering		No. of solders
	Soldering surface temperature	Heating time	Soldering temperature	Soldering time	
RDC501, RDC502	100 to 150°C	1 min. max.	260±5°C	10±1s	1 time
RD7	100°C max.	1 min. max.	260°C max.	5s max.	1 time

■ Example of Reflow Soldering Condition

- Cleaning sensors should not be attempted.
- Type of solder to be used Use cream solder that contains 10 to 15 wt % flux.
- Number of solder applications - apply solder only once
- Recommended reflow conditions

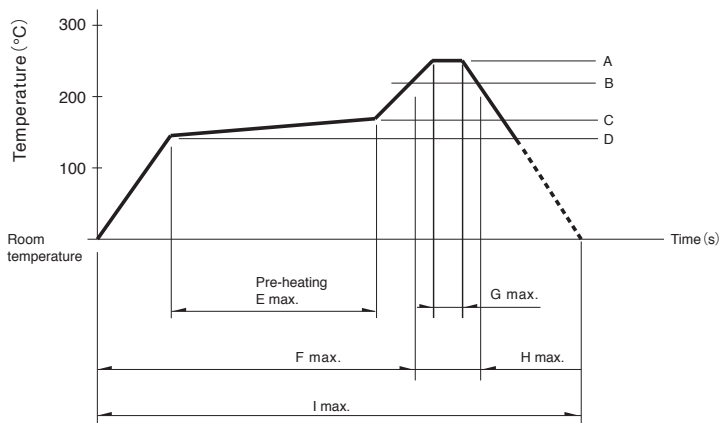

Series	A	B	C	D	E	F	G	H	I	No. of reflows
RDC503 RDC506	250°C	230°C	180°C	150°C	2min.	—	5s	40s	4min.	1 time
RDC90	255°C	230°C	—	—	—	2min.	10s	1 min.	4min.	1 time

⚠️ Note

- When using an infrared reflow oven, solder may not always be applied as intended. Be sure to use a hot air reflow oven or a type that uses infrared rays in combination with hot air.
- The temperatures given above are the maximum temperatures at the terminals of the sensor when employing a hot air reflow method. The temperature of the PC board and the surface temperature of the sensor may vary greatly depending on the PC board material, its size and thickness. Ensure that the surface temperature of the sensor does not rise to 250°C or greater.
- Conditions vary to some extent depending on the type of reflow bath used. Be sure to give due consideration to this prior to use.

Resistive Position Sensors / Cautions

Use of Chemicals

The sensors make use of synthetic resins, therefore avoid use in environments where there is a strong presence of gases from chemicals such as ammonia, amines, alkaline aqueous solutions, aromatic hydrocarbons, ketones, esters and halogenated hydrocarbons.

Measures to Deal with Noise Problems

While data is being received from the sensor, on rare occasions, penetrating external noise may cause interference with the outputs.

To minimize the probability of this phenomenon pay attention to the following when you program the relevant software

ex)

- Receiving of data should always be repeated a number of times to ensure that you obtain a mean value.
- Have the system determine when/how to invalidate any data received in error.
- When doubt occurs let the system receive the subject data again and reconfirm that you have eliminated the anomaly.

Soldering

Avoid wiring and soldering that causes the solder to seep through to the top of the PC board (as illustrated). This can lead to a contact failure in the terminal section. If solder seepage is unavoidable, please consult with us.

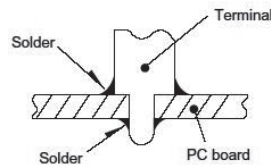

Connection Impedance

Resistive position sensors are constructed in a way that contact resistance (R_1 below) occurs within the sensor. To reduce the effect of contact resistance (R_1), set the impedance within the circuit connected to the output terminal to greater than $1M \Omega$.

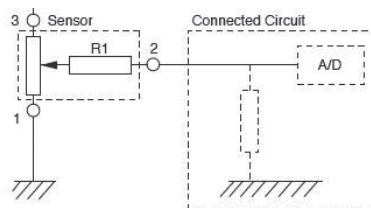

Dew Condensation

Avoid using the sensor where dew or water vapor might be caused to condense on the surface of the resistor - deterioration of insulation or shorting may occur.

Storage







1. Store the products as delivered, at a normal temperature and humidity, without direct sunshine and corrosive gas ambient. Use them at an earliest possible timing, not later than six months upon receipt.
2. After breaking the seal, keep the products in a plastic bag to shut out ambient air, store them in the same environment as above, and use them up as soon as possible.
3. Do not stack too many switches.

TACT Switch™

- Snap-in Type ————— 38
- Surface Mount Type ————— 62
- Radial Type ————— 124

Snap-in Type

List of Varieties

Series		SKHL	SKHH	SKHW	SKQJ	SKQB	SKQE	SKHC	
Photo									
Operation feeling		Sharp feeling							
Water-proof		—	—	—	—	●	—	—	
Dust-proof		—	—	●	●	●	●	—	
Operating direction	Top push	●	●	●	●	●	●	●	
	Side push	●	●	—	●	●	—	—	
Ground terminal		—	○	—	—	—	—	—	
Dimensions (mm)		6.0×3.5×4.3 6.0×3.5×5.0 7.3×6.72×4.3	6.0×6.0×4.3 6.0×6.0×5.0 6.0×6.0×7.0 6.0×6.0×7.3 6.0×6.0×9.5 6.0×6.0×13.0 6.0×6.0×17.0 6.2×7.85×7.1 6.2×9.85×7.1 6.2×12.35×7.1 6.2×19.85×7.1	6.0×6.0×4.3 6.0×6.0×5.0	6.6×6.6×5.0 6.6×6.6×7.0 6.6×6.6×9.5 7.0×7.85×7.0	10.0×10.0×5.0 10.0×10.0×13.0 10.0×10.0×23.2 11.1×11.9×11.0	12.0×12.0×4.3 12.0×12.0×7.3		
Operating force (N)		0.98 1.57 2.55	0.98 1.57 2.55 3.53 5.10	1.57 2.55	0.98 1.57	1.57 2.55		0.74 1.27 2.55	
Travel (mm)		0.25		0.3	0.25	0.3			
Operating temperature range		-20°C to +70°C -40°C to +90°C	-40°C to +90°C		-20°C to +70°C	-40°C to +90°C		-40°C to +85°C	
Electrical performance	Rating (max.)	50mA 12V DC							
	Rating (min.)	10μA 1V DC							
	Insulation resistance	100MΩ min. 100V DC for 1 min.							
	Voltage proof	250V AC for 1 min.							
Environmental performance	Cold	-30°C 96h -40°C 96h	-40°C 96h		-30°C 96h	-40°C 96h			
	Dry heat	80°C 96h 90°C 96h	90°C 96h		80°C 96h	90°C 96h			
	Damp heat	60°C, 90 to 95%RH 96h				60°C, 90 to 95%RH 1,000h	60°C, 90 to 95%RH 96h		
Automotive		●	○	—	—	●	—	—	

⚠ Note

● Indicates applicability to all products in the series, while ○ indicates applicability to some products in the series.

TACT Switch™ Snap-in Type

6.0×3.5mm (Snap-in) SKHL Series

Contributes to high-density mounting with top-push and side-push configurations.

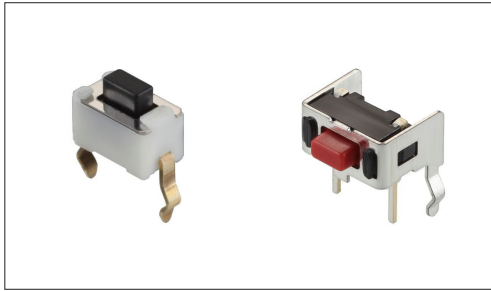

 Automotive

- Series type: Sharp feeling type
- Rating (max.): 50mA 12V DC
- Rating (min.): 10μA 1V DC

Applications: Energy_Industrial: Industrial equipment
 Healthcare: Healthcare equipment, Analysis, test equipment
 Home: Office equipment
 Audio_TV: Visual, Audio, Pro audio
 Automotive: Navigation/audio systems, HVAC

■ Product List

Products No.	Type	Operating direction	Operating force (N)	Travel (mm)	Operating life (cycles)	Initial contact resistance	Dimensions (W×D×H) (mm)	Water-proof	Dust-proof	Automotive	Drawing No.
SKHLAAA010	Top push type	Top push	0.98	0.25	50,000	500mΩ max.	6.0×3.5×4.3	—	—	●	1
SKHLACA010		Top push	1.57	0.25	50,000	500mΩ max.	6.0×3.5×4.3	—	—	●	
SKHLAJA010		Top push	2.55	0.25	30,000	500mΩ max.	6.0×3.5×4.3	—	—	●	
SKHLABA010		Top push	0.98	0.25	50,000	500mΩ max.	6.0×3.5×5.0	—	—	●	2
SKHLADA010		Top push	1.57	0.25	50,000	500mΩ max.	6.0×3.5×5.0	—	—	●	
SKHLAKA010		Top push	2.55	0.25	30,000	500mΩ max.	6.0×3.5×5.0	—	—	●	
SKHLLAA010	Side push type	Side push	0.98	0.25	50,000	500mΩ max.	7.3×6.72×4.3	—	—	●	3
SKHLLBA010		Side push	1.57	0.25	50,000	500mΩ max.	7.3×6.72×4.3	—	—	●	
SKHLLFA010		Side push	2.55	0.25	30,000	500mΩ max.	7.3×6.72×4.3	—	—	●	
SKHLLCA010		Side push	0.98	0.25	50,000	500mΩ max.	7.3×6.72×4.3	—	—	●	4
SKHLLDA010		Side push	1.57	0.25	50,000	500mΩ max.	7.3×6.72×4.3	—	—	●	

Note

1. This catalog shows only outline specifications. When using the products, please obtain formal specifications for supply.
2. Please place purchase orders per minimum order unit (integer).

■ Packing Specifications

Bulk

Number of packages (pcs.)		Export package measurements (mm)
1 case / Japan	1 case / export packing	
10,000	30,000	309×476×347

TACT Switch™ Snap-in Type

6.0×3.5mm (Snap-in)
SKHL Series

Drawing No.1

■ Dimensions

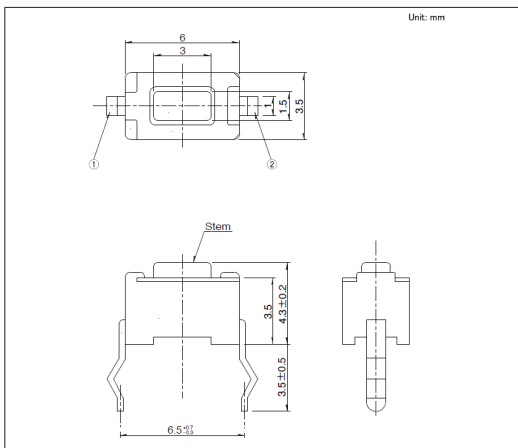

■ Mounting Hole Dimensions

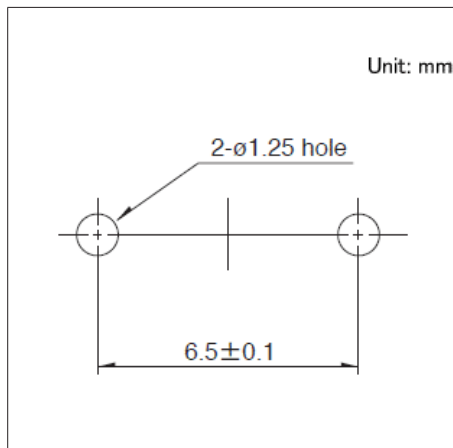

■ Circuit Diagram

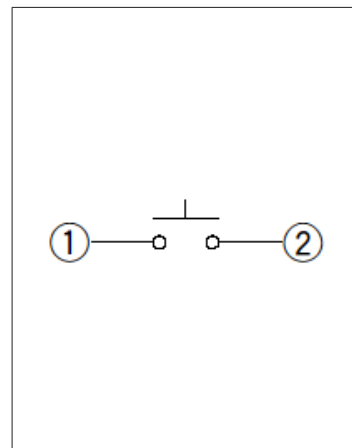

Viewed from mounting face.

Drawing No.2

■ Dimensions

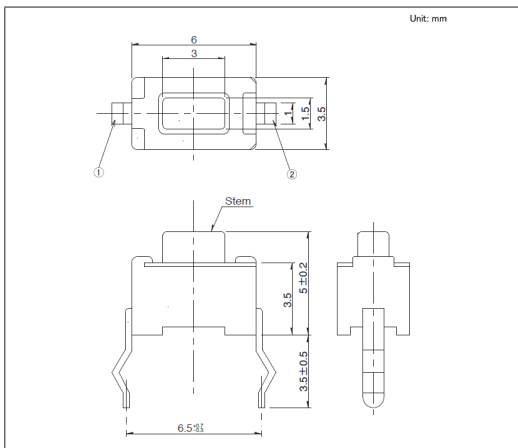

■ Mounting Hole Dimensions

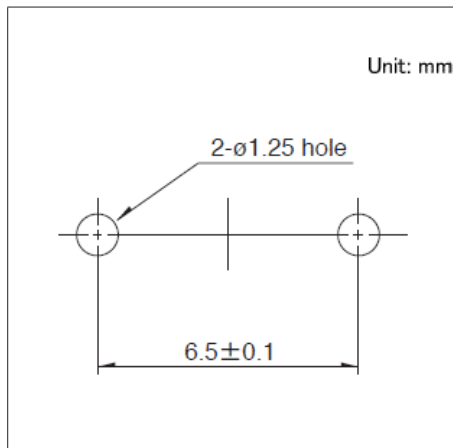

■ Circuit Diagram

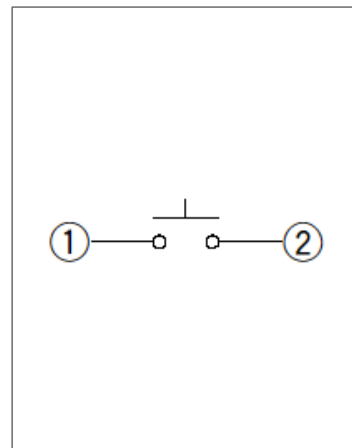

Viewed from mounting face.

Drawing No.3

■ Dimensions

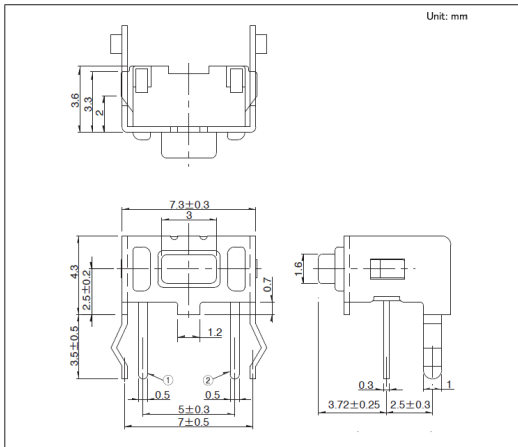

■ Mounting Hole Dimensions

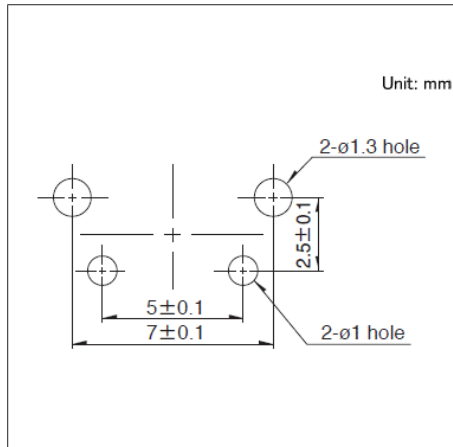

■ Circuit Diagram

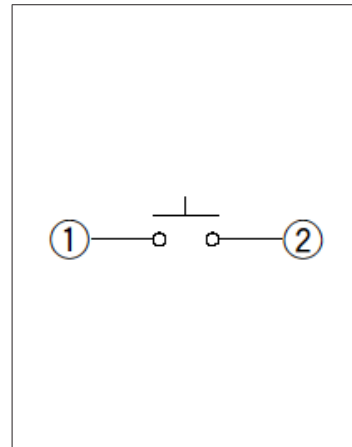

Viewed from mounting face.

TACT Switch™ Snap-in Type

6.0×3.5mm (Snap-in)
SKHL Series

Drawing No.4

■ Dimensions

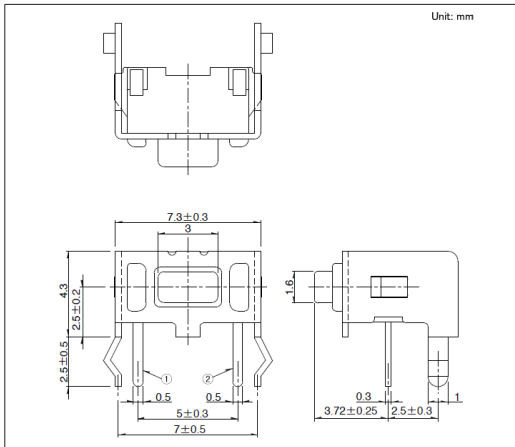

■ Mounting Hole Dimensions

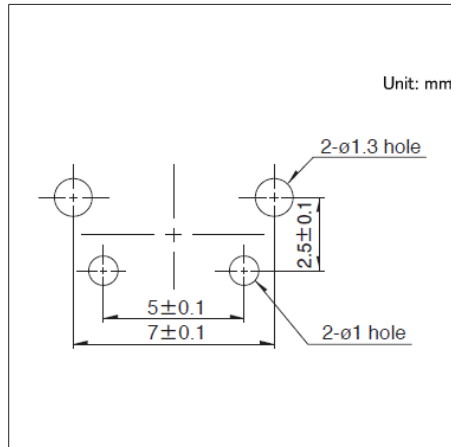

■ Circuit Diagram

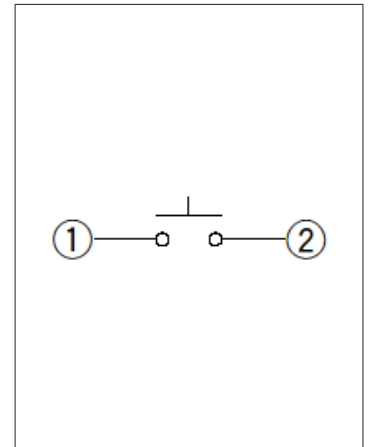

Viewed from mounting face.

TACT Switch™ Snap-in Type

6.0mm Square (Snap-in) SKHH Series

Renowned for ease of use and wide product variety in a 6.0mm square type.

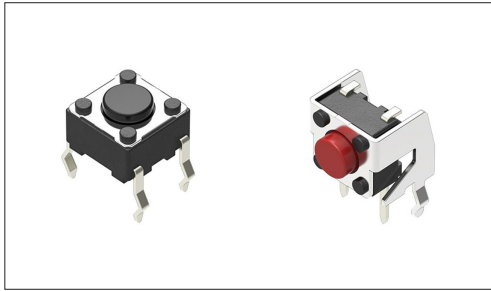

 Automotive

※Please check the product list for compatible products

- Series type: Sharp feeling type
- Rating (max.): 50mA 12V DC
- Rating (min.): 10μA 1V DC

Applications: Energy_Industrial: Industrial equipment
 Healthcare: Healthcare equipment, Analysis, test equipment
 Home: Office equipment
 Audio_TV: Visual, Audio, Pro audio
 Automotive: Navigation/audio systems, HVAC

■ Product List

Products No.	Type	Operating direction	Operating force (N)	Travel (mm)	Operating life (cycles)	Initial contact resistance	Dimensions (W×D×H) (mm)	Water-proof	Dust-proof	Automotive	Drawing No.
SKHHAJA010	Top push type	Top push	0.98	0.25	1,000,000	100mΩ max.	6.0×6.0×4.3	—	—	●	1
SKHHALA010		Top push	1.57	0.25	500,000	100mΩ max.	6.0×6.0×4.3	—	—	●	
SKHHAQA010		Top push	2.55	0.25	200,000	100mΩ max.	6.0×6.0×4.3	—	—	●	
SKHHAKA010		Top push	0.98	0.25	1,000,000	100mΩ max.	6.0×6.0×5.0	—	—	●	2
SKHHAMA010		Top push	1.57	0.25	500,000	100mΩ max.	6.0×6.0×5.0	—	—	●	
SKHHARA010		Top push	2.55	0.25	200,000	100mΩ max.	6.0×6.0×5.0	—	—	●	
SKHHCQA010		Top push	3.53	0.25	200,000	100mΩ max.	6.0×6.0×5.0	—	—	●	
SKHHCRA010		Top push	5.10	0.25	200,000	100mΩ max.	6.0×6.0×5.0	—	—	●	
SKHHBVA010		Top push	0.98	0.25	1,000,000	100mΩ max.	6.0×6.0×7.0	—	—	●	3
SKHHBWA010		Top push	1.57	0.25	500,000	100mΩ max.	6.0×6.0×7.0	—	—	●	
SKHHBYA010		Top push	2.55	0.25	200,000	100mΩ max.	6.0×6.0×7.0	—	—	●	
SKHHANA010		Top push	0.98	0.25	1,000,000	100mΩ max.	6.0×6.0×9.5	—	—	●	4
SKHHAPA010		Top push	1.57	0.25	500,000	100mΩ max.	6.0×6.0×9.5	—	—	●	
SKHHBSA010		Top push	2.55	0.25	200,000	100mΩ max.	6.0×6.0×9.5	—	—	●	
SKHHDTA010		Top push	0.98	0.25	1,000,000	100mΩ max.	6.0×6.0×13.0	—	—	●	5
SKHHDUA010		Top push	1.57	0.25	500,000	100mΩ max.	6.0×6.0×13.0	—	—	●	
SKHHDHA010	Top push	0.98	0.25	500,000	100mΩ max.	6.0×6.0×17.0	—	—	●	6	
SKHHDJA010	Top push	1.57	0.25	300,000	100mΩ max.	6.0×6.0×17.0	—	—	●		
SKHHCWA010	Joint stem type	Top push	0.98	0.25	1,000,000	100mΩ max.	6.0×6.0×7.3	—	—	●	7
SKHHDAA010		Top push	1.57	0.25	500,000	100mΩ max.	6.0×6.0×7.3	—	—	●	
SKHHDGA010		Top push	2.55	0.25	200,000	100mΩ max.	6.0×6.0×7.3	—	—	●	

TACT Switch™ Snap-in Type

6.0mm Square (Snap-in)
SKHH Series

Products No.	Type	Operating direction	Operating force (N)	Travel (mm)	Operating life (cycles)	Initial contact resistance	Dimensions (W×D×H) (mm)	Water-proof	Dust-proof	Automotive	Drawing No.	
SKHHPJA010	With ground terminal type	Top push	0.98	0.25	1,000,000	100mΩ max.	6.0×6.0×4.3	—	—	●	8	
SKHHPLA010		Top push	1.57	0.25	500,000	100mΩ max.	6.0×6.0×4.3	—	—	●		
SKHHPQA010		Top push	2.55	0.25	200,000	100mΩ max.	6.0×6.0×4.3	—	—	●		
SKHHPKA010		9	Top push	0.98	0.25	1,000,000	100mΩ max.	6.0×6.0×5.0	—	—	●	
SKHHPMA010			Top push	1.57	0.25	500,000	100mΩ max.	6.0×6.0×5.0	—	—	●	
SKHHPRA010			Top push	2.55	0.25	200,000	100mΩ max.	6.0×6.0×5.0	—	—	●	
SKHHQVA010			10	Top push	0.98	0.25	1,000,000	100mΩ max.	6.0×6.0×7.0	—	—	●
SKHHQWA010				Top push	1.57	0.25	500,000	100mΩ max.	6.0×6.0×7.0	—	—	●
SKHHQYA010				Top push	2.55	0.25	200,000	100mΩ max.	6.0×6.0×7.0	—	—	●
SKHHPNA010		11	Top push	0.98	0.25	1,000,000	100mΩ max.	6.0×6.0×9.5	—	—	●	
SKHHPPA010			Top push	1.57	0.25	500,000	100mΩ max.	6.0×6.0×9.5	—	—	●	
SKHHQNA010			Top push	2.55	0.25	200,000	100mΩ max.	6.0×6.0×9.5	—	—	●	
SKHHLMA010	Side push type	Side push	0.98	0.25	1,000,000	100mΩ max.	6.2×7.85×7.1	—	—	—	12	
SKHHLNA010		Side push	1.57	0.25	500,000	100mΩ max.	6.2×7.85×7.1	—	—	—		
SKHHLPA010		Side push	2.55	0.25	200,000	100mΩ max.	6.2×7.85×7.1	—	—	—		
SKHHLQA010		13	Side push	0.98	0.25	1,000,000	100mΩ max.	6.2×12.35×7.1	—	—	—	
SKHHLRA010			Side push	1.57	0.25	500,000	100mΩ max.	6.2×12.35×7.1	—	—	—	
SKHHLSA010			Side push	2.55	0.25	200,000	100mΩ max.	6.2×12.35×7.1	—	—	—	
SKHHLUA010			14	Side push	0.98	0.25	1,000,000	100mΩ max.	6.2×9.85×7.1	—	—	—
SKHHLVA010				Side push	1.57	0.25	500,000	100mΩ max.	6.2×9.85×7.1	—	—	—
SKHHLWA010				Side push	2.55	0.25	200,000	100mΩ max.	6.2×9.85×7.1	—	—	—
SKHHNHA010		15	Side push	0.98	0.25	500,000	100mΩ max.	6.2×19.85×7.1	—	—	—	
SKHHNJA010			Side push	1.57	0.25	300,000	100mΩ max.	6.2×19.85×7.1	—	—	—	
SKHHNKA010			Side push	2.55	0.25	200,000	100mΩ max.	6.2×19.85×7.1	—	—	—	

 Note

1. This catalog shows only outline specifications. When using the products, please obtain formal specifications for supply.
2. Please use 1.6mm thick PC boards.
3. Please place purchase orders per minimum order unit (integer).

TACT Switch™ Snap-in Type

6.0mm Square (Snap-in)
SKHH Series

■ Packing Specifications

Bulk

Products No.	Number of packages(pcs.)		Export package measurements (mm)
	1 case / Japan	1 case / export packing	
SKHHAJA010 SKHHALA010 SKHHAQA010 SKHHAKA010 SKHHAMA010 SKHHARA010 SKHHCQA010 SKHHCRA010 SKHHBVA010 SKHHBWA010 SKHHBYA010 SKHHANA010 SKHHAPA010 SKHHBSA010 SKHHCWA010 SKHHDAA010 SKHHDGA010 SKHHPJA010 SKHHPLA010 SKHHPQA010 SKHHPKA010 SKHHPMA010 SKHHPRA010 SKHHQVA010 SKHHQWA010 SKHHQYA010 SKHHPNA010 SKHHPPA010 SKHHQNA010 SKHHLMA010 SKHHLNA010 SKHHLPA010 SKHHLQA010 SKHHLRA010 SKHHLSA010 SKHHLUA010 SKHHLVA010 SKHHLWA010	10,000	30,000	309 x 476 x 347
SKHHDTA010 SKHHDUA010 SKHHDHA010 SKHHDJA010 SKHHNHA010 SKHHNJA010 SKHHNKA010	5,000	15,000	309 x 476 x 347

Drawing No.1

■ Dimensions

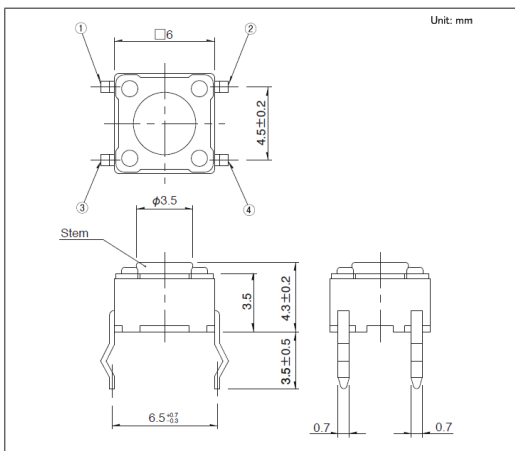

■ Mounting Hole Dimensions

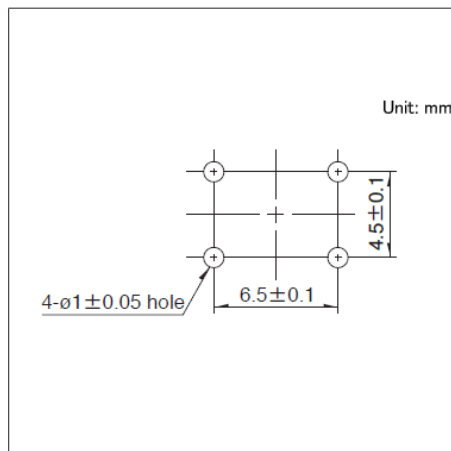

■ Circuit Diagram

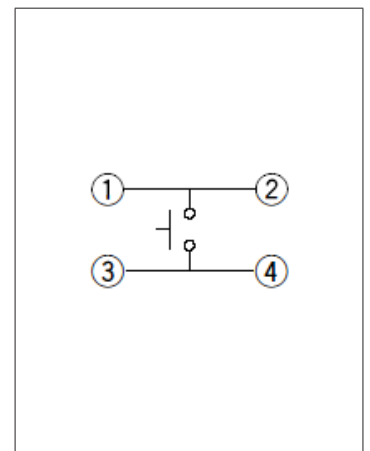

Viewed from mounting face.

Drawing No.2

■ Dimensions

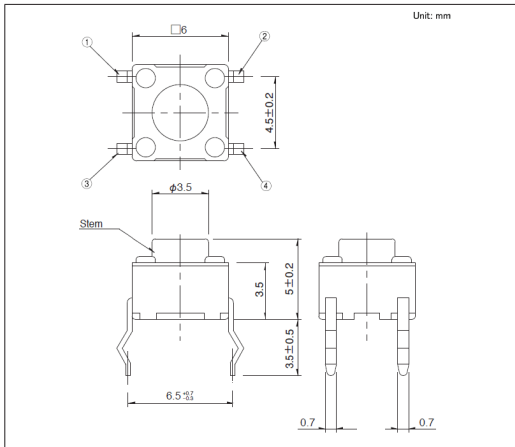

■ Mounting Hole Dimensions

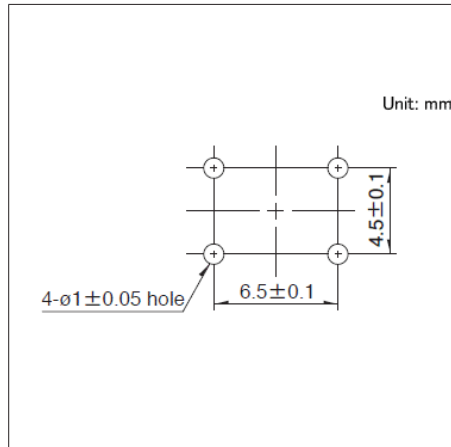

■ Circuit Diagram

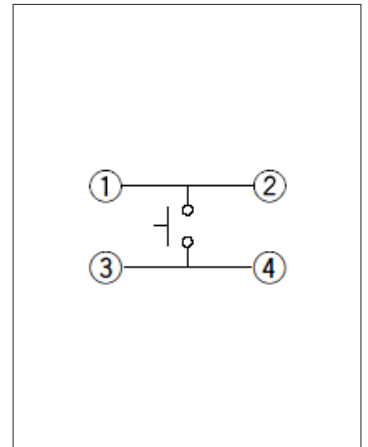

Viewed from mounting face.

Drawing No.3

■ Dimensions

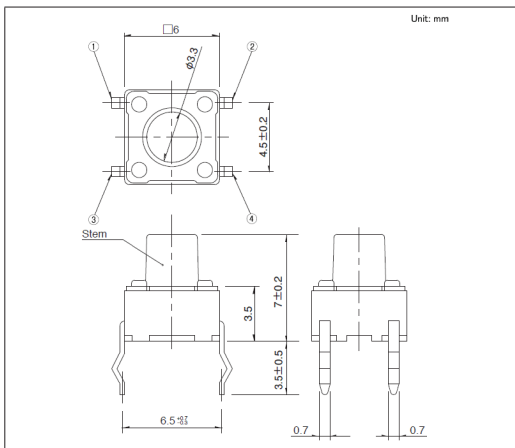

■ Mounting Hole Dimensions

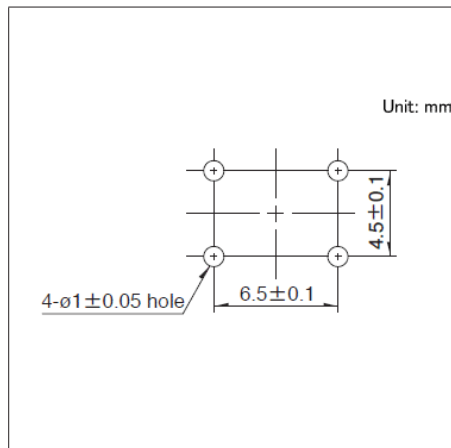

■ Circuit Diagram

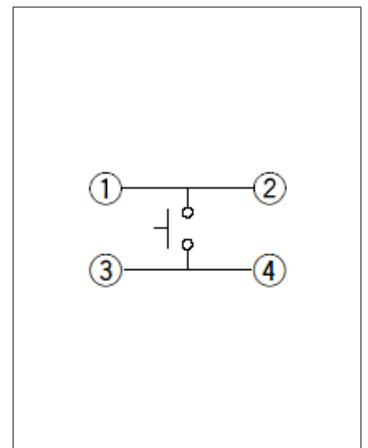

Viewed from mounting face.

Drawing No.4

■ Dimensions

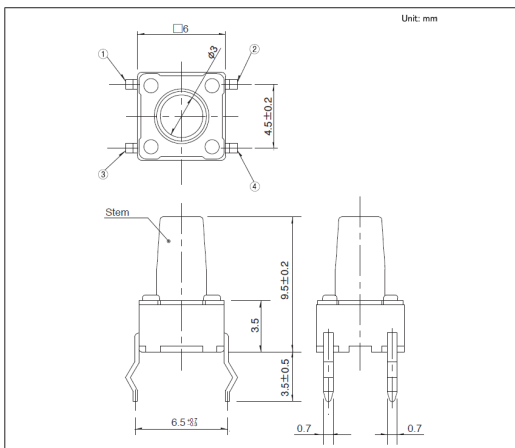

■ Mounting Hole Dimensions

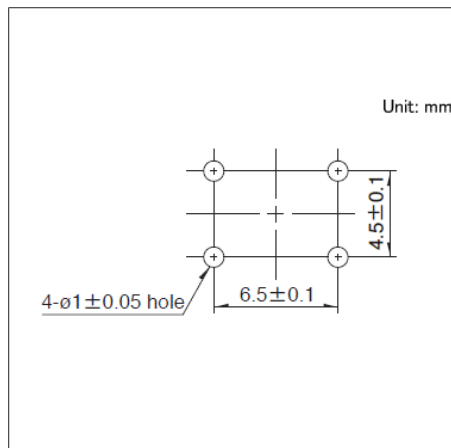

■ Circuit Diagram

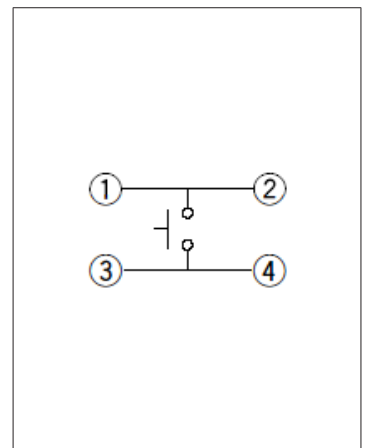

Viewed from mounting face.

TACT Switch™ Snap-in Type

6.0mm Square (Snap-in)
SKHH Series

Drawing No.5

■ Dimensions

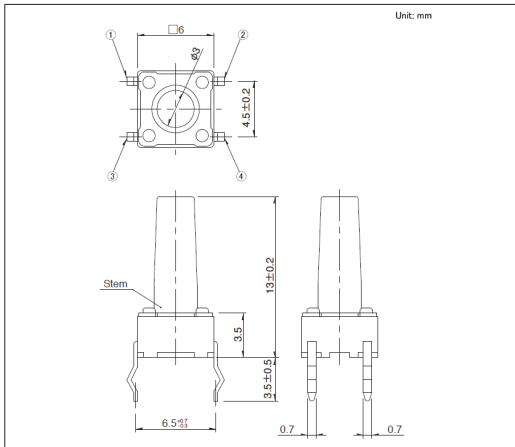

■ Mounting Hole Dimensions

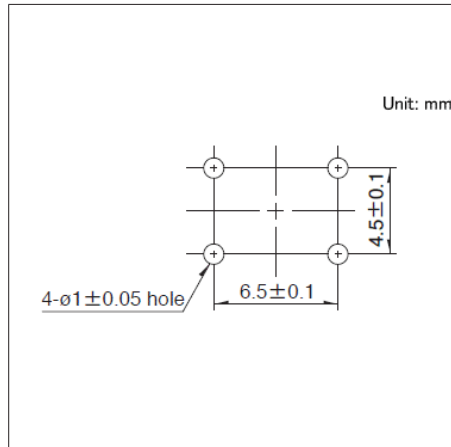

■ Circuit Diagram

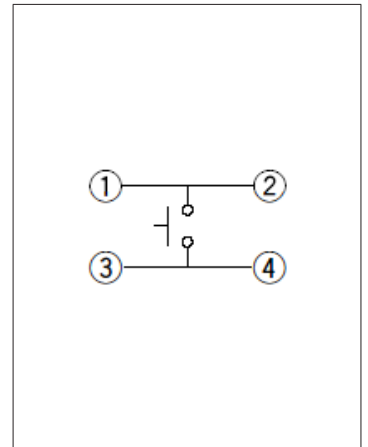

Viewed from mounting face.

Drawing No.6

■ Dimensions

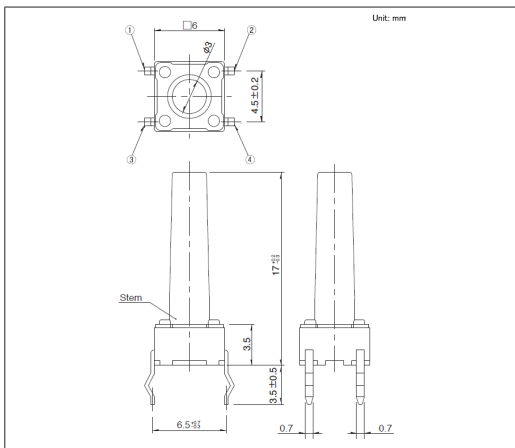

■ Mounting Hole Dimensions

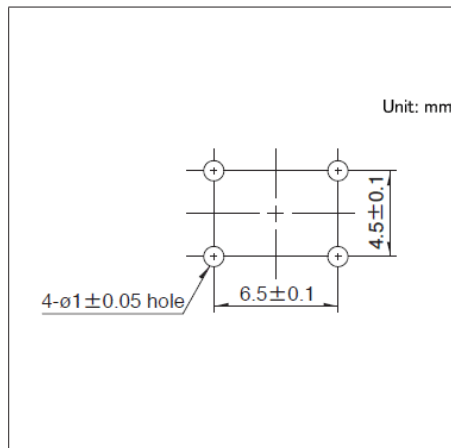

■ Circuit Diagram

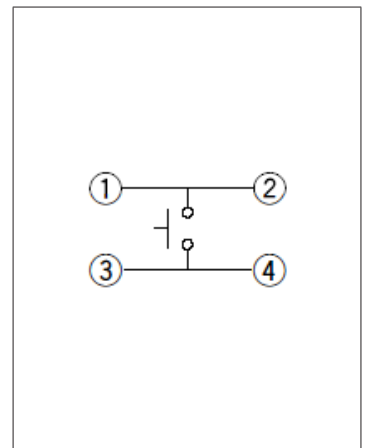

Viewed from mounting face.

Drawing No.7

■ Dimensions

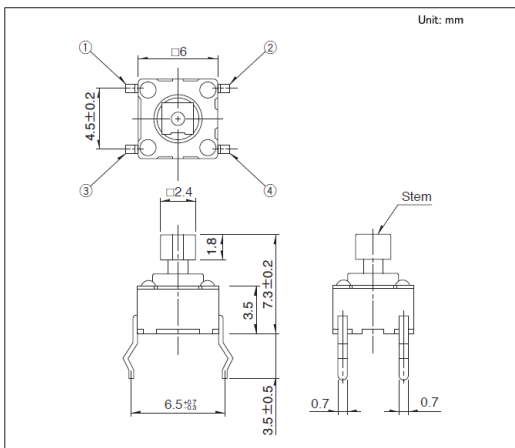

■ Mounting Hole Dimensions

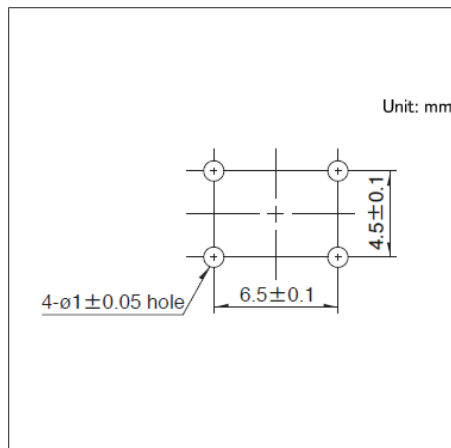

■ Circuit Diagram

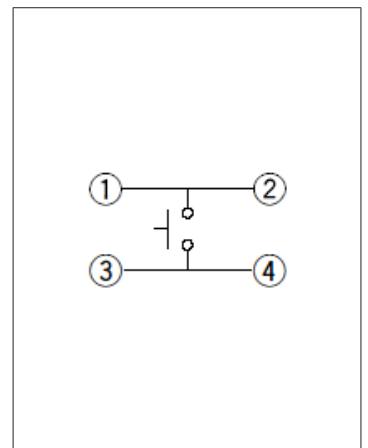

Viewed from mounting face.

TACT Switch™ Snap-in Type

6.0mm Square (Snap-in)
SKHH Series

Drawing No.8

■ Dimensions

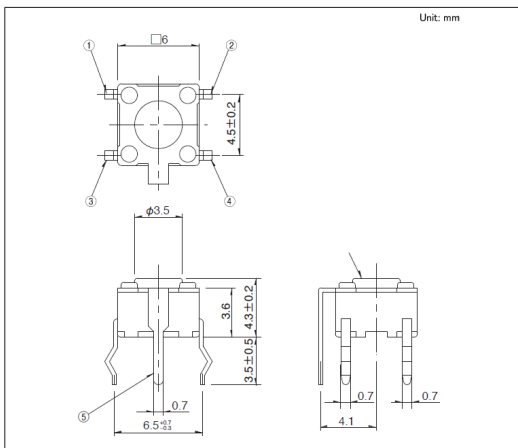

■ Mounting Hole Dimensions

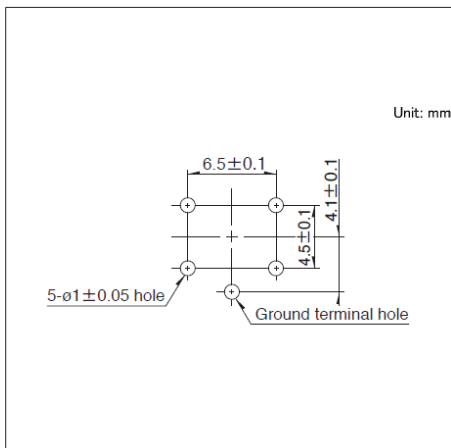

■ Circuit Diagram

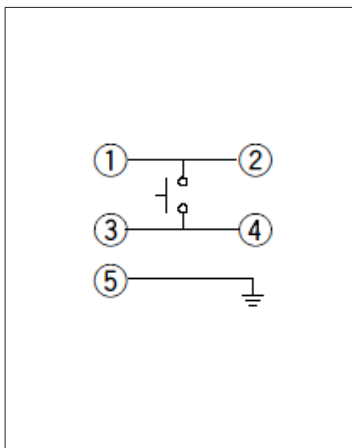

Viewed from mounting face.

Drawing No.9

■ Dimensions

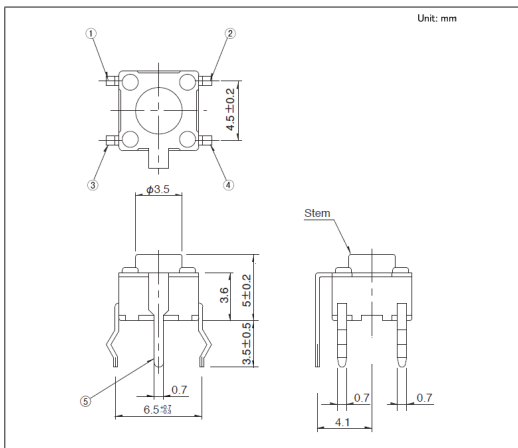

■ Mounting Hole Dimensions

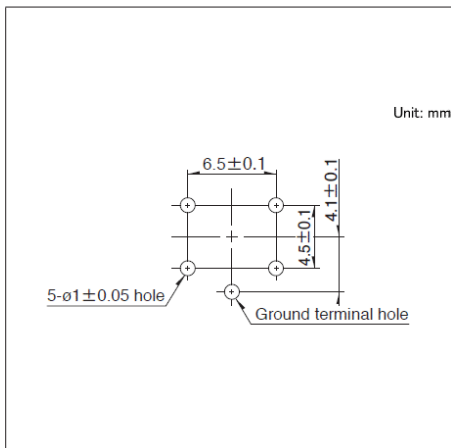

■ Circuit Diagram

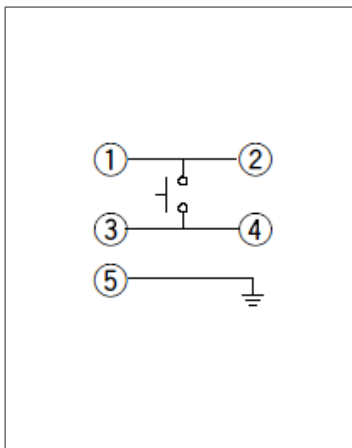

Viewed from mounting face.

Drawing No.10

■ Dimensions

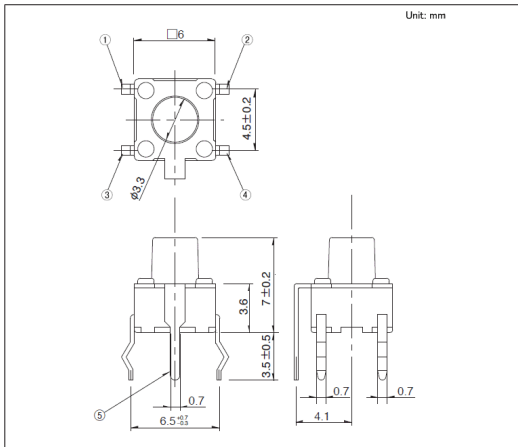

■ Mounting Hole Dimensions

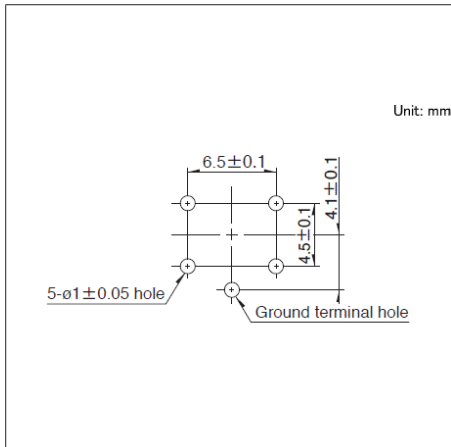

■ Circuit Diagram

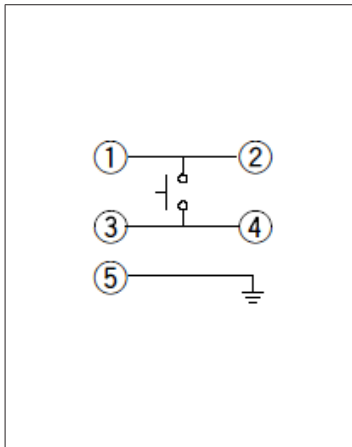

Viewed from mounting face.

TACT Switch™ Snap-in Type

6.0mm Square (Snap-in)
SKHH Series

Drawing No.11

■ Dimensions

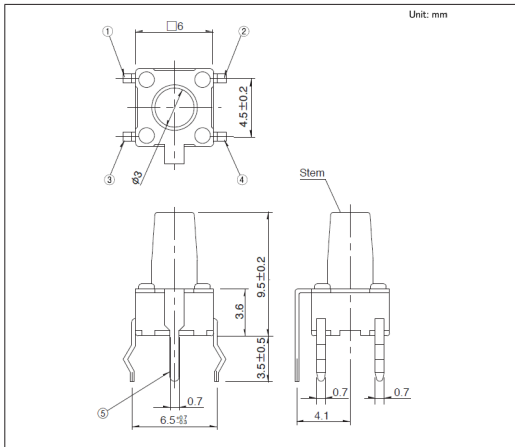

■ Mounting Hole Dimensions

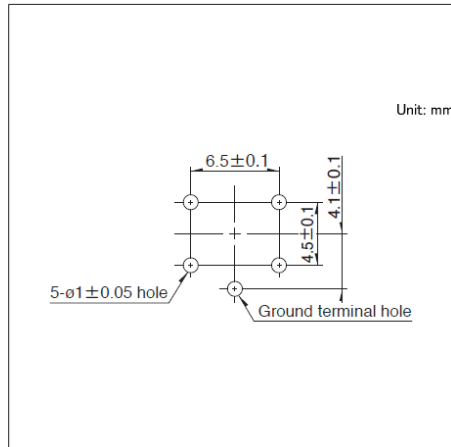

■ Circuit Diagram

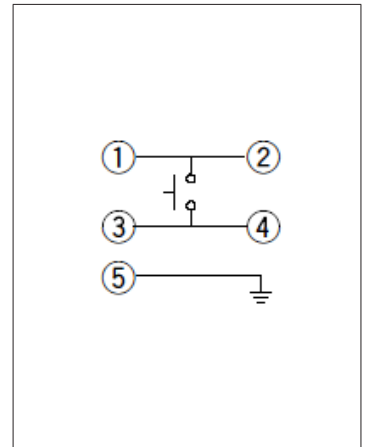

Viewed from mounting face.

Drawing No.12

■ Dimensions

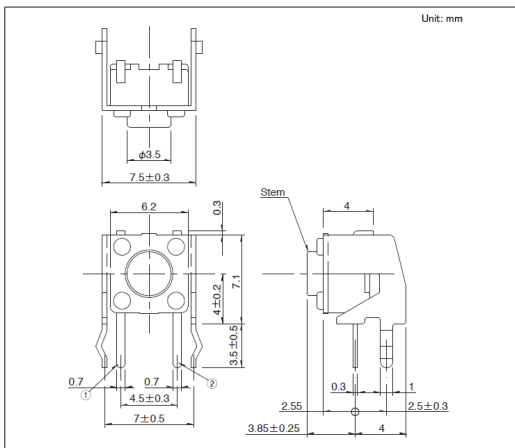

■ Mounting Hole Dimensions

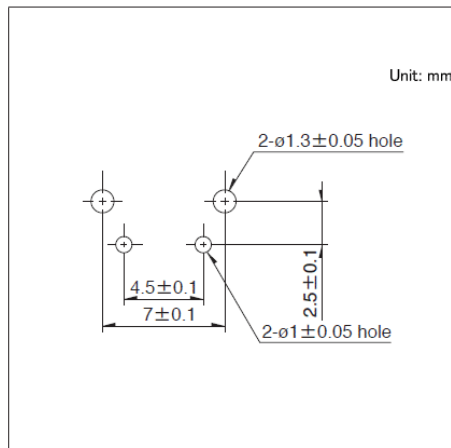

■ Circuit Diagram

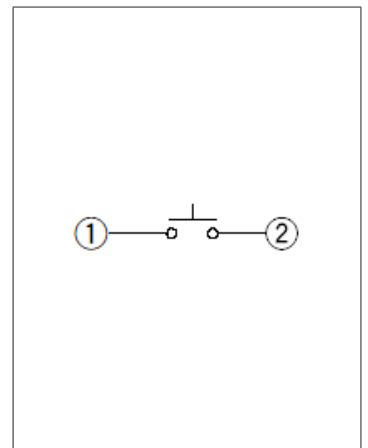

Viewed from mounting face.

Drawing No.13

■ Dimensions

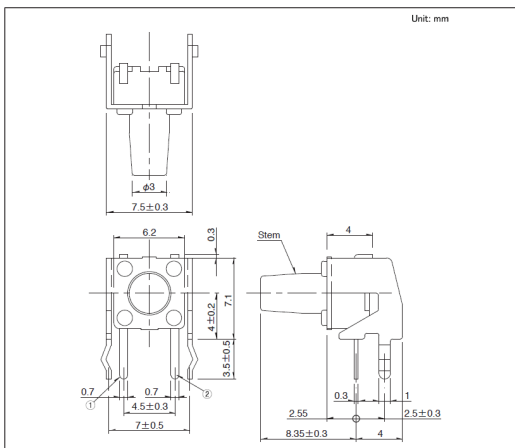

■ Mounting Hole Dimensions

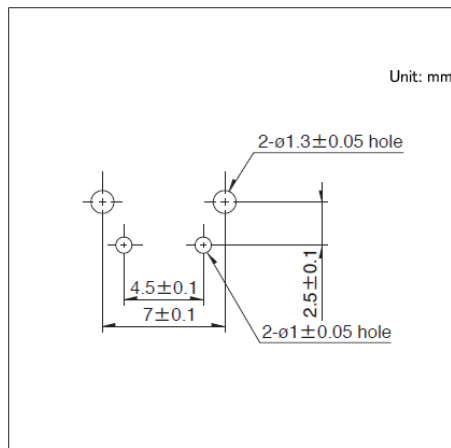

■ Circuit Diagram

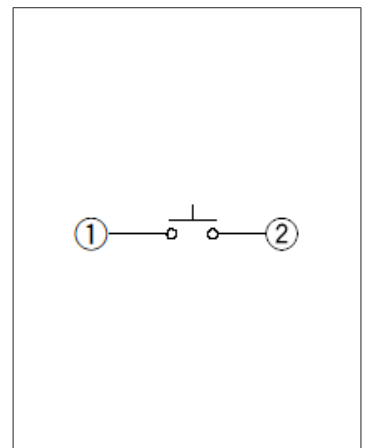

Viewed from mounting face.

Drawing No.14

■ Dimensions

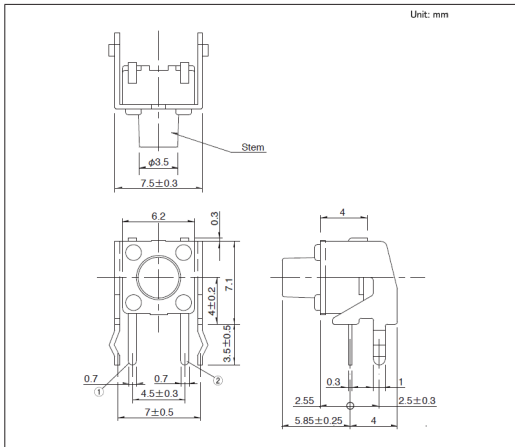

■ Mounting Hole Dimensions

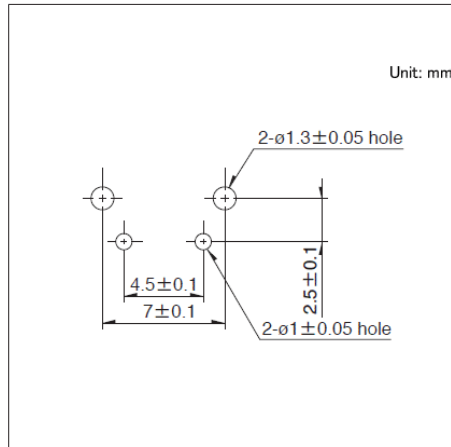

■ Circuit Diagram

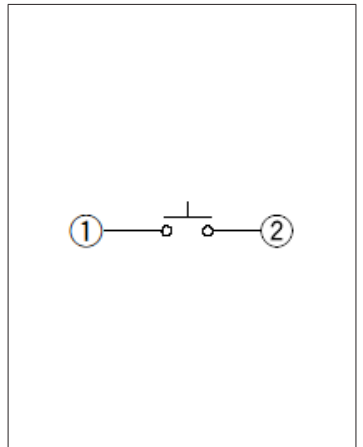

Viewed from mounting face.

Drawing No.15

■ Dimensions

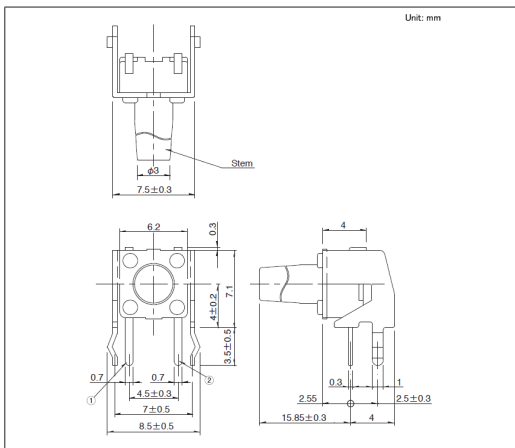

■ Mounting Hole Dimensions

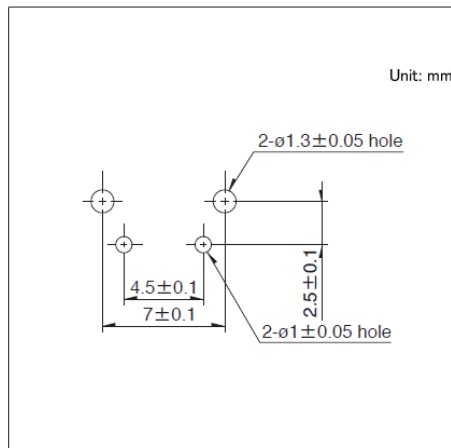

■ Circuit Diagram

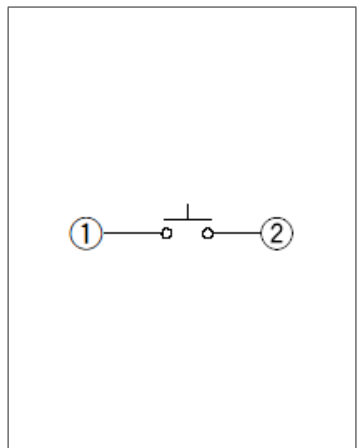

Viewed from mounting face.

TACT Switch™ Snap-in Type

6.0mm Square Dust-proof (Snap-in) SKHW Series

Supports a wide range of devices with unique dust-proof structure and sharp operation feel.



 Dust-proof Type

- Series type: Sharp feeling type
- Rating (max.): 50mA 12V DC
- Rating (min.): 10 μ A 1V DC

Applications: Energy_Industrial: Industrial equipment
Healthcare: Healthcare equipment, Analysis, test equipment
Home: Major home appliances, Office equipment
Audio_TV: Visual, Audio, Pro audio

Product List

Products No.	Operating direction	Operating force (N)	Travel (mm)	Operating life (cycles)	Initial contact resistance	Dimensions (W×D×H) (mm)	Water-proof	Dust-proof	Automotive	Drawing No.
SKHWALA010	Top push	1.57	0.3	1,000,000	100m Ω max.	6.0×6.0×4.3	—	●	—	1
SKHWARA010	Top push	2.55	0.3	500,000	100m Ω max.	6.0×6.0×4.3	—	●	—	
SKHWAPA010	Top push	1.57	0.3	1,000,000	100m Ω max.	6.0×6.0×5.0	—	●	—	2
SKHWQA010	Top push	2.55	0.3	500,000	100m Ω max.	6.0×6.0×5.0	—	●	—	

Note

1. This catalog shows only outline specifications. When using the products, please obtain formal specifications for supply.
2. Please use 1.6mm thick PC boards.
3. Please place purchase orders per minimum order unit (integer).

Packing Specifications

Bulk

Number of packages (pcs.)		Export package measurements (mm)
1 case / Japan	1 case / export packing	
10,000	30,000	309 x 476 x 347

Drawing No. 1

Dimensions

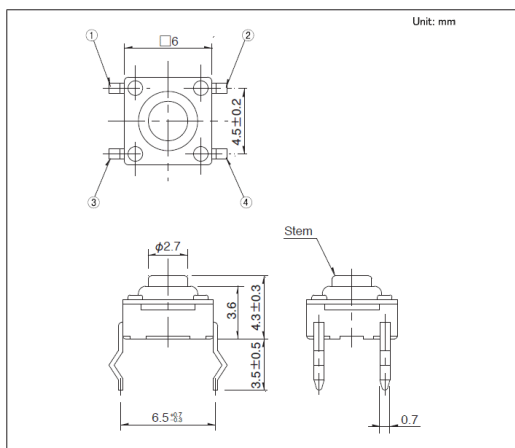

Mounting Hole Dimensions

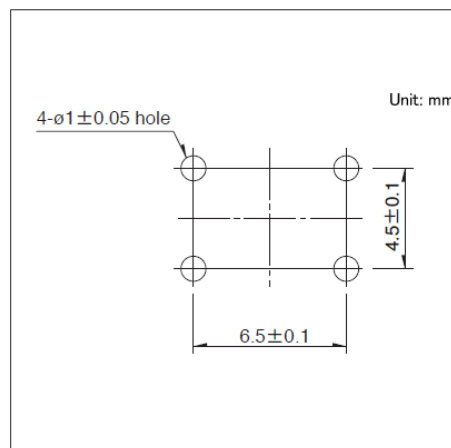

Circuit Diagram

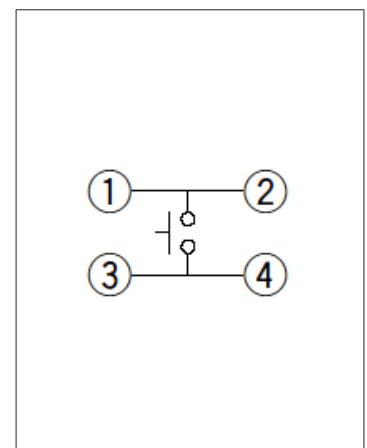

Viewed from mounting face.

TACT Switch™ Snap-in Type

6.0mm Square Dust-proof (Snap-in)

SKHW Series

Drawing No.2

■ Dimensions

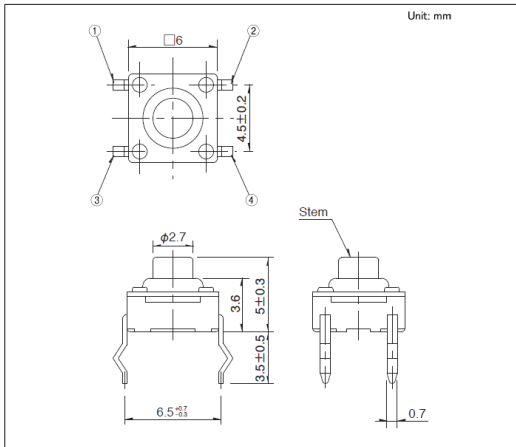

■ Mounting Hole Dimensions

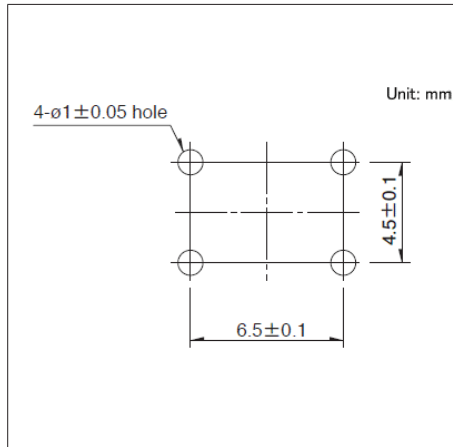

■ Circuit Diagram

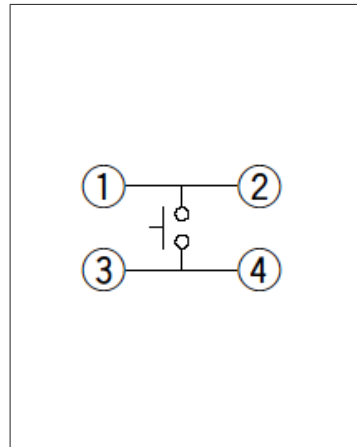

Viewed from mounting face.

TACT Switch™ Snap-in Type

6.6mm Square (Snap-in) SKQJ Series

Simple dust-proof type with sharp operation feel and excellent versatility.

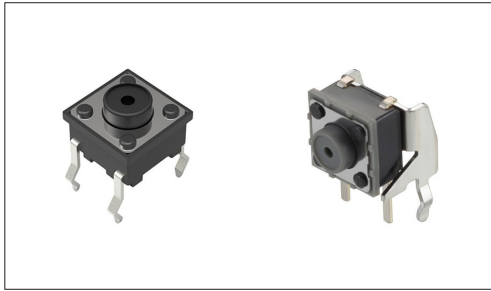

 Dust-proof Type

- Series type: Sharp feeling type
- Rating (max.): 50mA 12V DC
- Rating (min.): 10 μ A 1V DC

Applications: Energy_Industrial: Industrial equipment
 Healthcare: Healthcare equipment, Analysis, test equipment
 Home: Major home appliances, Office equipment
 Audio_TV: Visual, Audio, Pro audio

Product List

Products No.	Type	Operating direction	Operating force (N)	Travel (mm)	Operating life (cycles)	Initial contact resistance	Dimensions (WxDxH) (mm)	Water-proof	Dust-proof	Automotive	Drawing No.
SKQJAAA010	Top push type	Top push	0.98	0.25	1,000,000	100m Ω max.	6.6×6.6×5.0	—	●	—	1
SKQJABA010		Top push	1.57	0.25	500,000	100m Ω max.	6.6×6.6×5.0	—	●	—	
SKQJADA010		Top push	0.98	0.25	1,000,000	100m Ω max.	6.6×6.6×7.0	—	●	—	2
SKQJAEA010		Top push	1.57	0.25	500,000	100m Ω max.	6.6×6.6×7.0	—	●	—	
SKQJAJA010		Top push	0.98	0.25	200,000	100m Ω max.	6.6×6.6×9.5	—	●	—	3
SKQJAKA010		Top push	1.57	0.25	200,000	100m Ω max.	6.6×6.6×9.5	—	●	—	
SKQJLAA010	Side push type	Side push	0.98	0.25	1,000,000	100m Ω max.	7.0×7.85×7.0	—	●	—	4
SKQJLBA010		Side push	1.57	0.25	500,000	100m Ω max.	7.0×7.85×7.0	—	●	—	

Note

1. This catalog shows only outline specifications. When using the products, please obtain formal specifications for supply.
2. Please use 1.6mm thick PC boards.
3. Please place purchase orders per minimum order unit (integer).

Packing Specifications

Bulk

Number of packages (pcs.)		Export package measurements (mm)
1 case / Japan	1 case / export packing	
10,000	30,000	309 x 476 x 347

TACT Switch™ Snap-in Type

6.6mm Square (Snap-in)
SKQJ Series

Drawing No.1

■ Dimensions

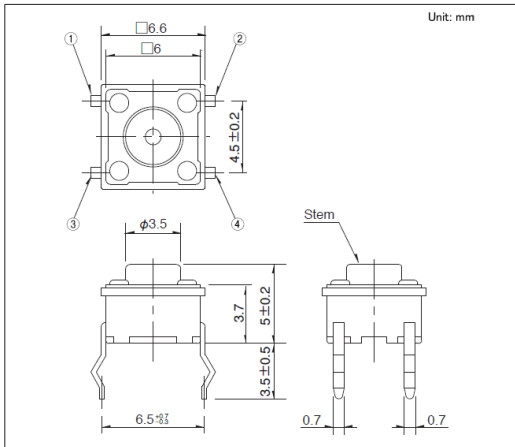

■ Mounting Hole Dimensions

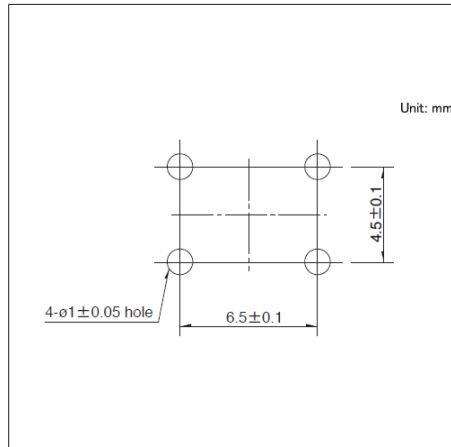

■ Circuit Diagram

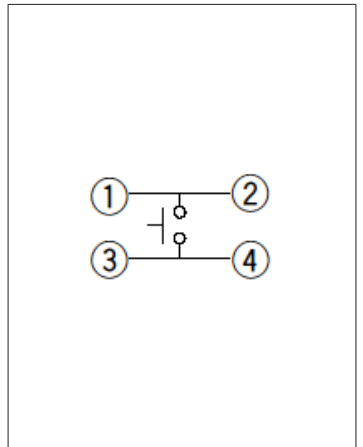

Viewed from mounting face.

Drawing No.2

■ Dimensions

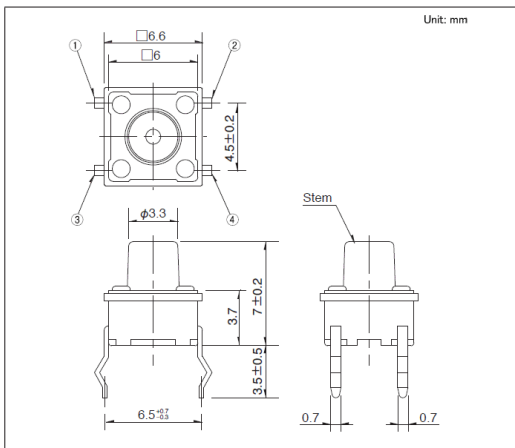

■ Mounting Hole Dimensions

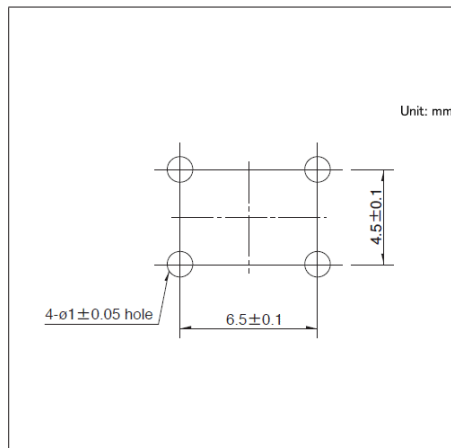

■ Circuit Diagram

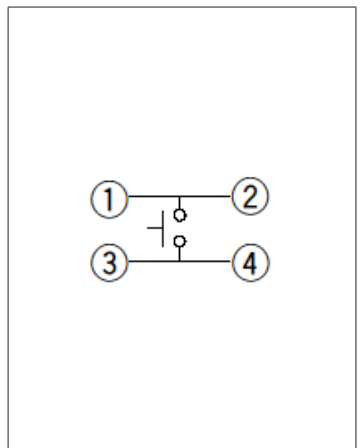

Viewed from mounting face.

Drawing No.3

■ Dimensions

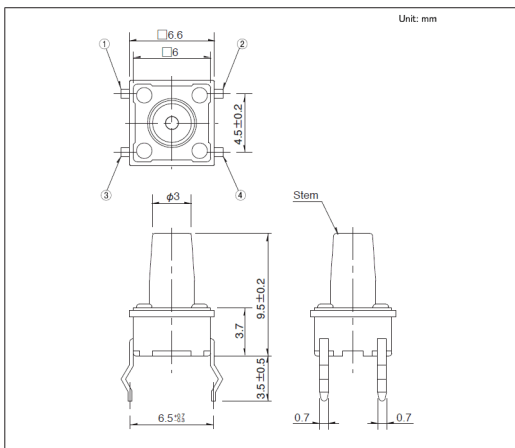

■ Mounting Hole Dimensions

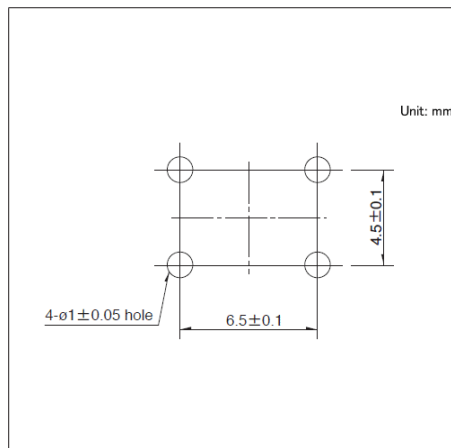

■ Circuit Diagram

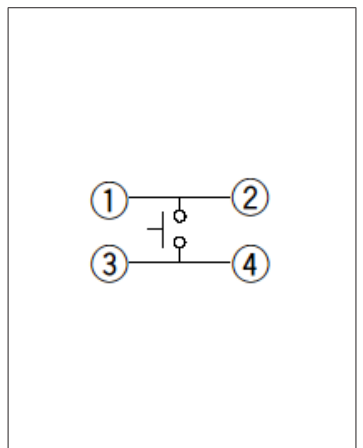

Viewed from mounting face.

TACT Switch™ Snap-in Type

6.6mm Square (Snap-in)
SKQJ Series

Drawing No.4

■ Dimensions

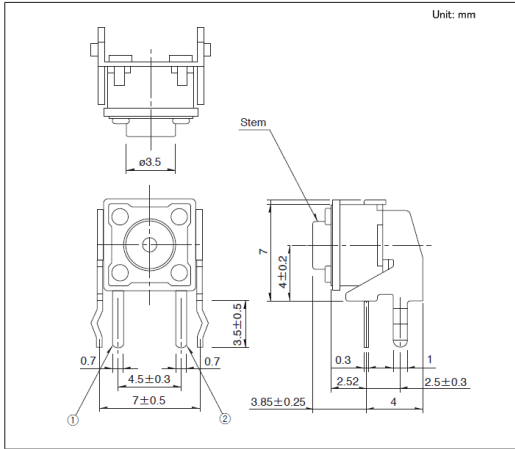

■ Mounting Hole Dimensions

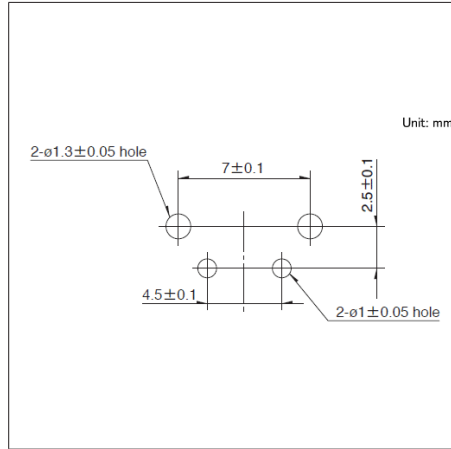

■ Circuit Diagram

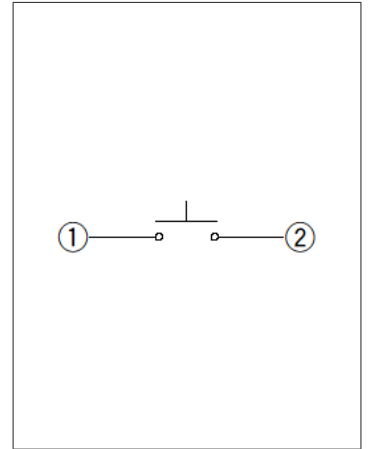

Viewed from mounting face.

TACT Switch™ Snap-in Type

10mm Square (Snap-in) SKQB Series

Excellent water-proof and dust-proof structure, suitable for water-related household appliances.

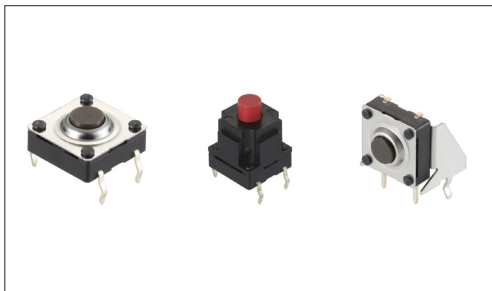

Automotive

Water-proof Type

Dust-proof Type

- Series type: Sharp feeling type
- Rating (max.): 50mA 12V DC
- Rating (min.): 10μA 1V DC

Applications: Energy_Industrial: Industrial equipment
 Healthcare: Healthcare equipment, Analysis, test equipment
 Home: Major home appliances, Office equipment
 Automotive: Hood Latch (Side/Rear/Door/Gear),
 Navigation/audio systems, HVAC,
 Overhead consoles, Steering, Shifter

■ Product List

Products No.	Type	Operating direction	Operating force (N)	Travel (mm)	Operating life (cycles)	Initial contact resistance	Dimensions (W×D×H) (mm)	Water-proof	Dust-proof	Water-proof & Dust-proof	Automotive	Drawing No.
SKQBARA010	Top push type	Top push	1.57	0.3	100,000	500mΩ max.	10.0×10.0×5.0	●	●	Conditions: Coating the terminals	●	1
SKQBASA010		Top push	2.55	0.3	100,000	500mΩ max.	10.0×10.0×5.0	●	●	Conditions: Coating the terminals	●	
SKQBAPA010		Top push	1.57	0.3	100,000	500mΩ max.	10.0×10.0×13.0	●	●	Conditions: Coating the terminals	●	2
SKQBAJA010		Top push	2.55	0.3	100,000	500mΩ max.	10.0×10.0×13.0	●	●	Conditions: Coating the terminals	●	
SKQBAQA010		Top push	1.57	0.3	100,000	500mΩ max.	10.0×10.0×23.2	●	●	Conditions: Coating the terminals	●	3
SKQBAMA010		Top push	2.55	0.3	100,000	500mΩ max.	10.0×10.0×23.2	●	●	Conditions: Coating the terminals	●	
SKQBLBA010	Side push type	Side push	1.57	0.3	100,000	500mΩ max.	11.1×11.9×11.0	●	●	Conditions: Coating the terminals	●	4

Note

1. This catalog shows only outline specifications. When using the products, please obtain formal specifications for supply.
2. Switch terminals must be coated thoroughly until the terminals are fully covered.
3. When the switch is used in an environment subject to high humidity or condensation, make sure the terminals are coated thoroughly to prevent current leakage between terminals.
4. Avoid using coating material coating toluene or xylene. For more information on coating material, please contact us.
5. Please use 1.6mm thick PC boards.
6. Please place purchase orders per minimum order unit (integer).

■ Packing Specifications

Bulk

Products No.	Number of packages (pcs.)		Export package measurements (mm)
	1 case / Japan	1 case / export packing	
SKQBARA010 SKQBASA010 SKQBAPA010 SKQBAJA010 SKQBLBA010	4,000	12,000	309 x 476 x 347
SKQBAQA010 SKQBAMA010	2,000	6,000	309 x 476 x 347

Drawing No.1

■ Dimensions

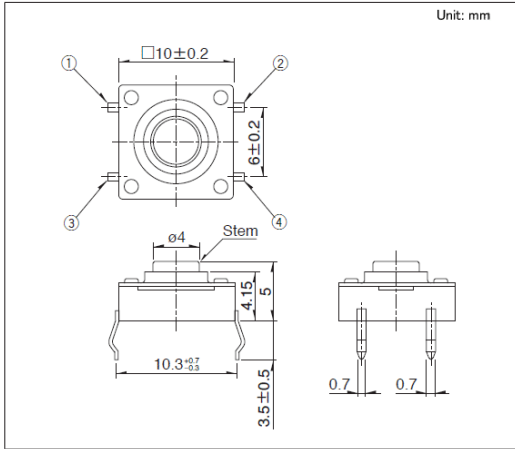

■ Mounting Hole Dimensions

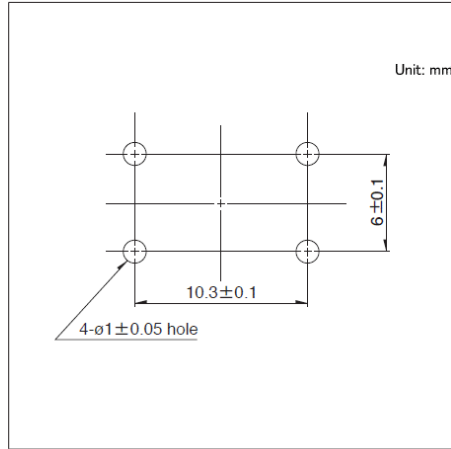

■ Circuit Diagram

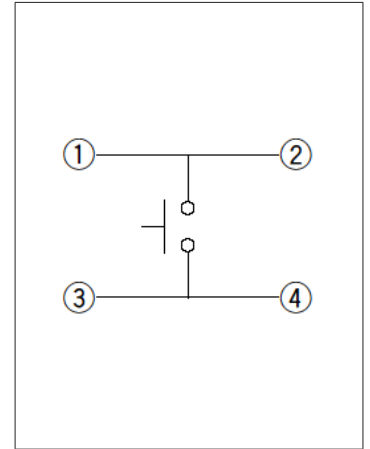

Viewed from mounting face.

Drawing No.2

■ Dimensions

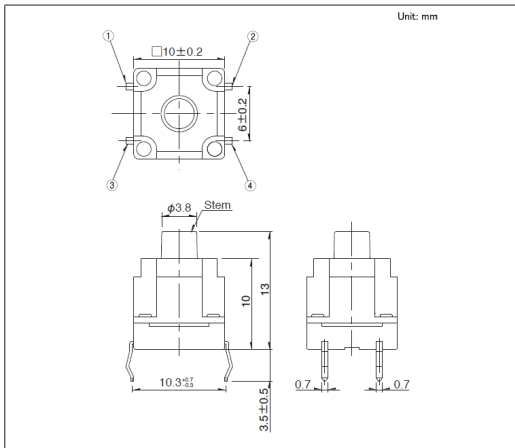

■ Mounting Hole Dimensions

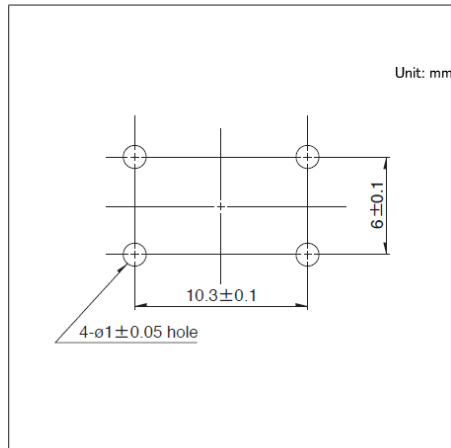

■ Circuit Diagram

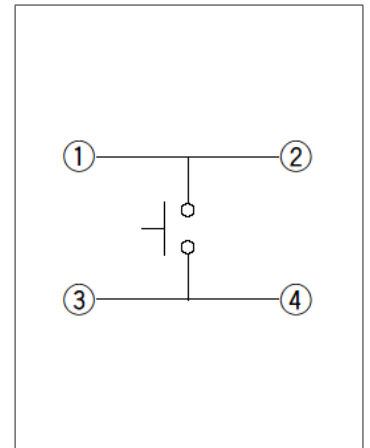

Viewed from mounting face.

Drawing No.3

■ Dimensions

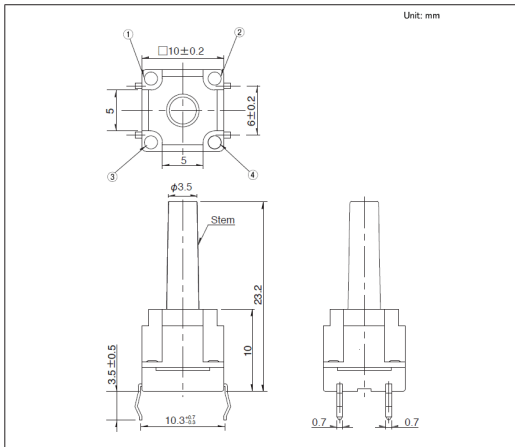

■ Mounting Hole Dimensions

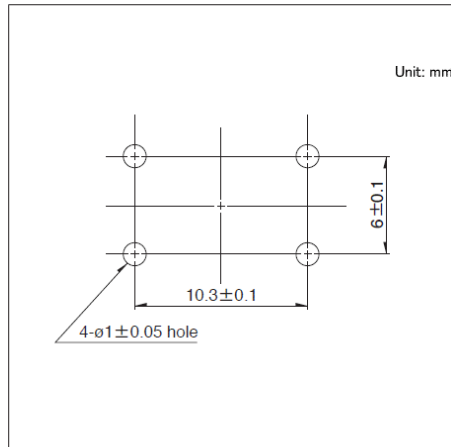

■ Circuit Diagram

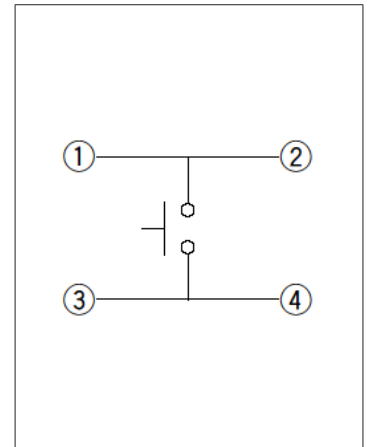

Viewed from mounting face.

TACT Switch™ Snap-in Type

10mm Square (Snap-in)
SKQB Series

Drawing No.4

■ Dimensions

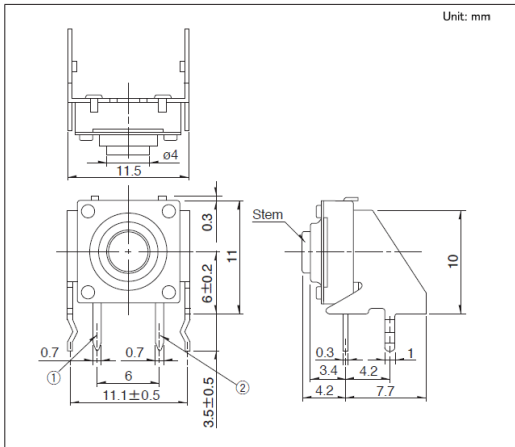

■ Mounting Hole Dimensions

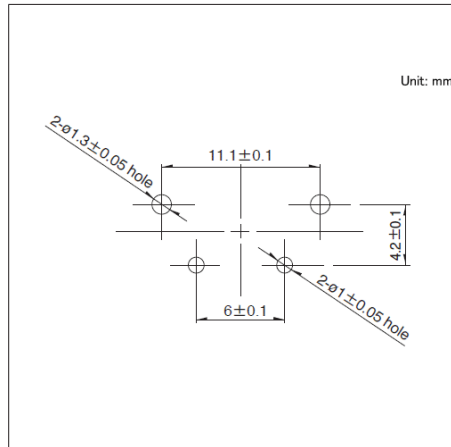

■ Circuit Diagram

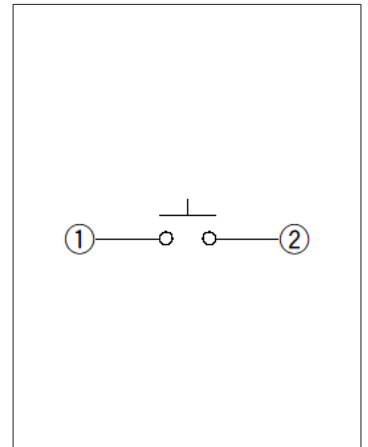

Viewed from mounting face.

TACT Switch™ Snap-in Type

12mm Square (Snap-in) SKQE Series

Long-life type with unique dust-proof structure and high-reliability metal contacts, capable of 10 million operations.

 Dust-proof Type

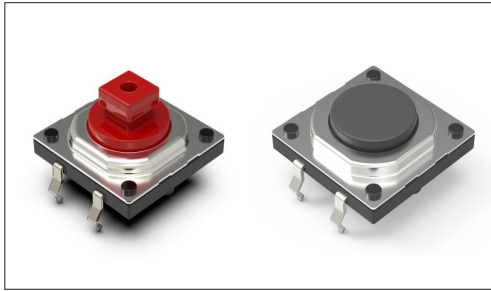

- Series type: Sharp feeling type
- Rating (max.): 50mA 12V DC
- Rating (min.): 10μA 1V DC

Applications: Energy_Industrial: Industrial equipment
Home: Major home appliances, Office equipment

Product List

Products No.	Operating direction	Operating force (N)	Travel (mm)	Operating life (cycles)	Initial contact resistance	Stem	Dimensions (W×D×H) (mm)	Water-proof	Dust-proof	Automotive	Drawing No.
SKQEAAA010	Top push	1.57	0.3	10,000,000	100mΩ max.	Joint stem	12.0×12.0×7.3	—	●	—	1
SKQEACA010	Top push	2.55	0.3	10,000,000	100mΩ max.	Joint stem	12.0×12.0×7.3	—	●	—	
SKQEABA010	Top push	1.57	0.3	10,000,000	100mΩ max.	Flat stem	12.0×12.0×4.3	—	●	—	2
SKQEADA010	Top push	2.55	0.3	10,000,000	100mΩ max.	Flat stem	12.0×12.0×4.3	—	●	—	

Note

1. This catalog shows only outline specifications. When using the products, please obtain formal specifications for supply.
2. Please use 1.6mm thick PC boards.
3. Please place purchase orders per minimum order unit (integer).

Packing Specifications

Bulk

Number of packages (pcs.)		Export package measurements (mm)
1 case / Japan	1 case / export packing	
4,000	12,000	309 x 476 x 347

Drawing No. 1

Dimensions

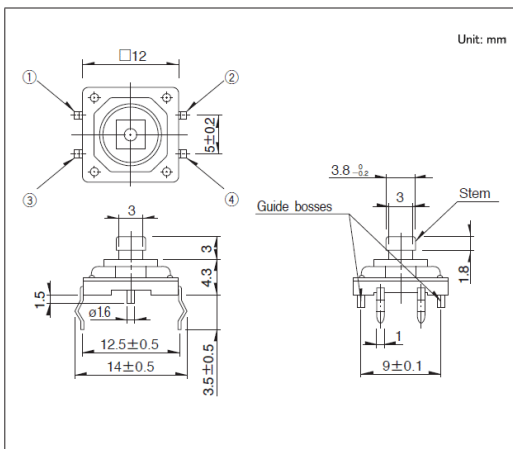

Mounting Hole Dimensions

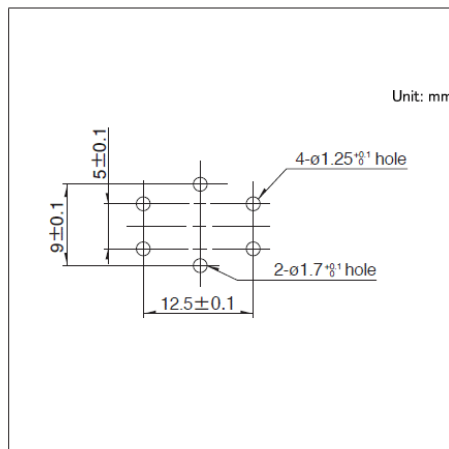

Circuit Diagram

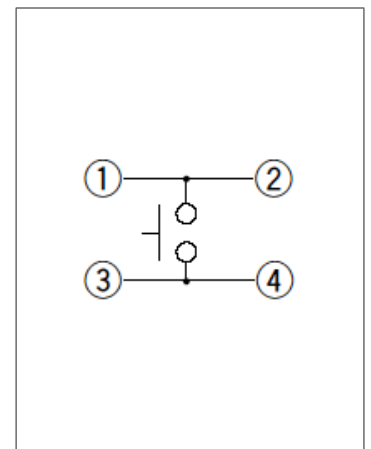

Viewed from mounting face.

TACT Switch™ Snap-in Type

12mm Square (Snap-in)
SKQE Series

Drawing No.2

■ Dimensions

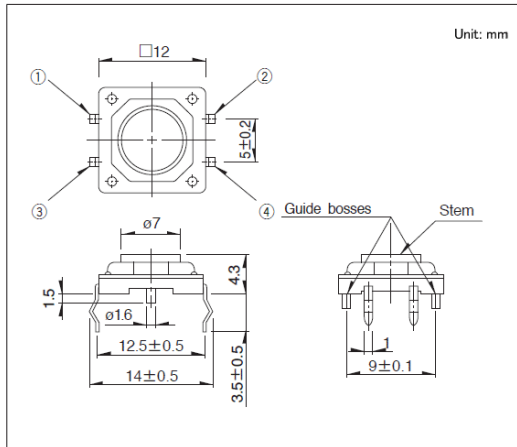

■ Mounting Hole Dimensions

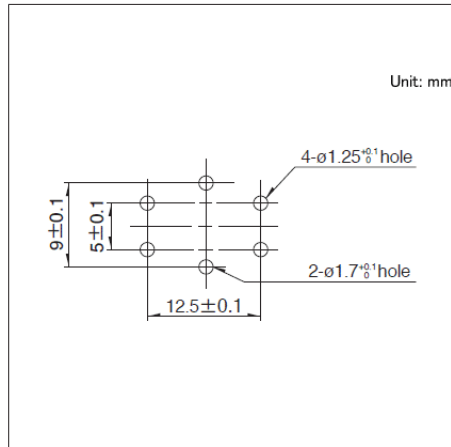

■ Circuit Diagram

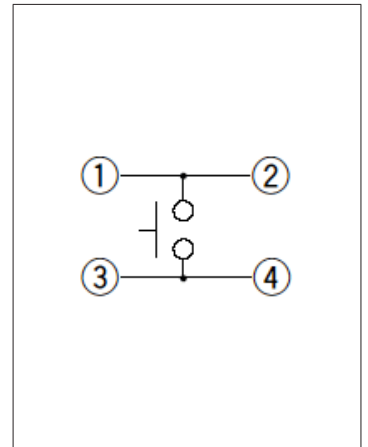

Viewed from mounting face.

TACT Switch™ Snap-in Type

12mm Square (Snap-in) SKHC Series

Features stable operation feel with joint stem and flat stem designs.



- Series type: Sharp feeling type
- Rating (max.): 50mA 12V DC
- Rating (min.): 10 μ A 1V DC

Applications: Energy_Industrial: Industrial equipment
Home: Office equipment

Product List

Products No.	Operating direction	Operating force (N)	Travel (mm)	Operating life (cycles)	Initial contact resistance	Stem	Dimensions (W×D×H) (mm)	Water-proof	Dust-proof	Automotive	Drawing No.
SKHCBJA010	Top push	0.74	0.3	500,000	100m Ω max.	Joint stem	12.0×12.0×7.3	—	—	—	1
SKHCBEA010	Top push	1.27	0.3	1,000,000	100m Ω max.	Joint stem	12.0×12.0×7.3	—	—	—	
SKHCBLA010	Top push	1.27	0.3	3,000,000	100m Ω max.	Joint stem	12.0×12.0×7.3	—	—	—	
SKHCBGA010	Top push	2.55	0.3	500,000	100m Ω max.	Joint stem	12.0×12.0×7.3	—	—	—	
SKHCBKA010	Top push	0.74	0.3	500,000	100m Ω max.	Flat stem	12.0×12.0×4.3	—	—	—	2
SKHCBFA010	Top push	1.27	0.3	1,000,000	100m Ω max.	Flat stem	12.0×12.0×4.3	—	—	—	
SKHCBMA010	Top push	1.27	0.3	3,000,000	100m Ω max.	Flat stem	12.0×12.0×4.3	—	—	—	
SKHCBHA010	Top push	2.55	0.3	500,000	100m Ω max.	Flat stem	12.0×12.0×4.3	—	—	—	

Note

1. This catalog shows only outline specifications. When using the products, please obtain formal specifications for supply.
2. Please use 1.6mm thick PC boards.
3. Please place purchase orders per minimum order unit (integer).

Packing Specifications

Bulk

Number of packages (pcs.)		Export package measurements (mm)
1 case / Japan	1 case / export packing	
5,000	15,000	309 x 476 x 347

TACT Switch™ Snap-in Type

12mm Square (Snap-in)
SKHC Series

Drawing No.1

■ Dimensions

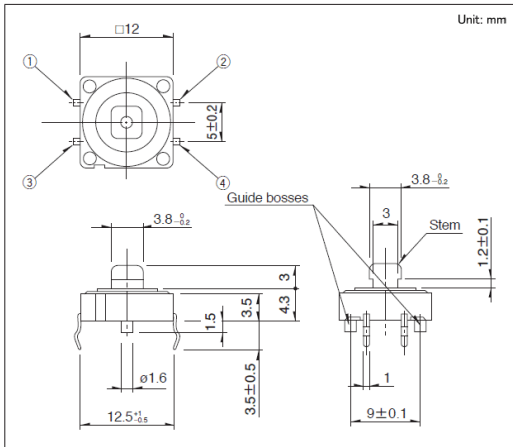

■ Mounting Hole Dimensions

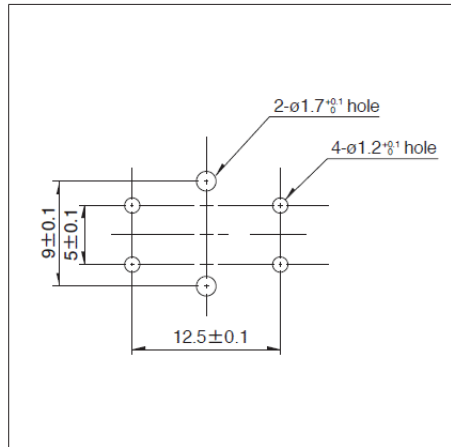

■ Circuit Diagram

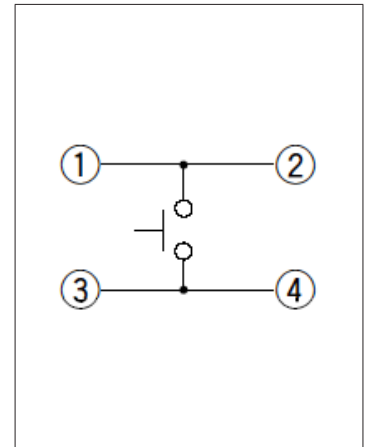

Viewed from mounting face.

Drawing No.2

■ Dimensions

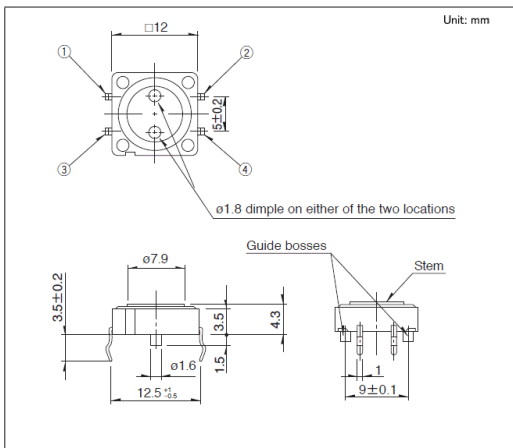

■ Mounting Hole Dimensions

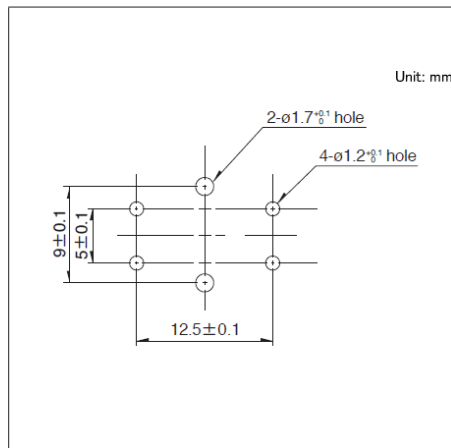



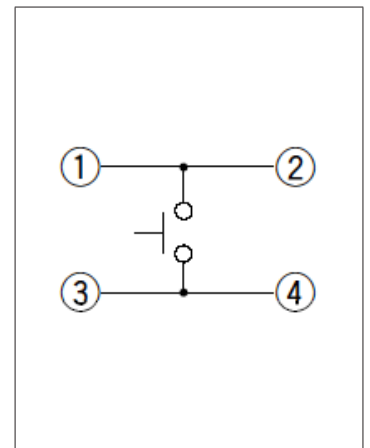

■ Circuit Diagram

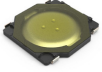
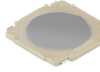

Viewed from mounting face.

Surface Mount Type

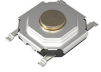

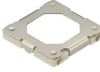



List of Varieties

Series		SKRW	SKRM	SKRB	SKRR	SKQG	SKSD	SKRN
Photo								
Operation feeling		Sharp feeling						
Water-proof		—	—	—	—	—	—	—
Dust-proof		—	—	—	—	—	—	—
IP standard		—	—	—	—	—	—	—
Operating direction	Top push	●	●	●	●	●	●	●
	Side push	—	—	—	—	—	—	—
Ground terminal		—	—	—	—	—	—	—
Dimensions (mm)		3.7×3.7×0.35	4.5×4.5×0.4	4.8×4.8×0.55	7.5×7.0×0.6	5.2 x 5.2×1.5	4.1×3.9×0.6	6.0×6.0×0.9
Operating force (N)		1.27 1.57 2.35	1.57 2.55	1.1 1.57 2.55 3.5	1.0 1.6 2.0	0.98 1.57 2.55 3.43	1st 0.8, 2nd 1.6 1st 0.8, 2nd 1.9	1st 0.59, 2nd 1.57 1st 0.78, 2nd 1.57 1st 0.78, 2nd 2.45
Travel (mm)		0.15	0.15 0.2		0.25		1st 0.15, All 0.25	1st 0.25, All 0.4
Operating temperature range		-30°C to +85°C -30°C to +86°C -30°C to +87°C	-40°C to +85°C			-40°C to +90°C		
Electrical performance	Rating (max.)	50mA 12V DC						
	Rating (min.)	10μA 1V DC						
	Insulation resistance	100MΩ min. 100V DC for 1 min.						
	Voltage proof	100V AC for 1 min.				250V AC for 1 min.	100V AC for 1 min.	250V AC for 1 min.
Environmental performance	Cold	-40°C 96h						
	Dry heat	90°C 96h						
	Damp heat	60°C, 90 to 95%RH 96h						
Automotive		—	—	●	—	●	—	—

⚠ Note

● Indicates applicability to all products in the series, while ○ indicates applicability to some products in the series.







Surface Mount Type

Series		SKUB	SKTA	SKSV	SKSW	SKTK	SKUA	SKSG	
Photo									
Operation feeling		Sharp feeling							
Water-proof		●	●	●	●	●	●	—	
Dust-proof		●	●	●	●	●	●	—	
IP standard		IP6X equivalent/ IPX8	IP6X equivalent/ IPX7	IP6X equivalent/ IPX7	IP6X equivalent/ IPX7 IP6X equivalent/ IPX8	IP6X equivalent/ IPX7	IP6X equivalent/ IPX7	—	
Operating direction	Top push	●	●	●	●	●	●	●	
	Side push	—	—	—	—	—	—	—	
Ground terminal		—	—	—	—	—	—	○	
Dimensions (mm)		2.4×1.4×0.55	2.6×1.6×0.53	2.8×1.9×0.5 2.8×1.9×0.55	3.0×2.0×0.6	5.9×4.0×0.78	7.0×7.5×0.67	3.0×2.7×1.4	
Operating force (N)		1.6	1.0 1.6	1.0 1.6 2.2	1.6 1.8 2.4 3.3	2.5	2.0	1.6 2.0 2.8 4.0	
Travel (mm)		0.11		0.12	0.13	0.23	0.22	0.12	
Operating temperature range		-30°C to +85°C					-40°C to +90°C	-40°C to +85°C	
Electrical performance	Rating (max.)	50mA 12V DC							
	Rating (min.)	10μA 1V DC							
	Insulation resistance	100MΩ min. 100V DC for 1 min.							
	Voltage proof	100V AC for 1 min.							
Environmental performance	Cold	-40°C 96h							
	Dry heat	90°C 96h							
	Damp heat	60°C, 90 to 95%RH 96h							
Automotive		—	—	—	—	—	—	●	

 Note

● Indicates applicability to all products in the series, while ○ indicates applicability to some products in the series.



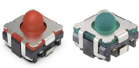



Surface Mount Type

Series		SKRK	SKTH	SKRP	SKQM	SKQY	SKTQ	SKSU
Photo								
Operation feeling		Sharp feeling						
Water-proof		—	—	—	—	—	—	●
Dust-proof		—	●	—	—	—	—	●
IP standard		—	IP6X equivalent	—	—	—	—	IP6X equivalent/ IPX7
Operating direction	Top push	●	●	●	●	●	●	●
	Side push	—	—	—	—	—	—	—
Ground terminal		—	—	—	—	○	—	—
Dimensions (mm)		3.9×2.9×1.5 3.9×2.9×2.0	3.5×3.2×1.75 3.5×3.2×1.8 3.5×3.2×2.5	4.2×3.2×2.5	6.0×3.5×4.3 6.0×3.5×5.0	6.1×3.7×2.5	5.3×5.4×4.25	5.3×5.4×3.85 5.3×5.4×4.34
Operating force (N)		0.98 1.57	1.4 3.0 5.0 7.0	1.0 1.57 2.55 3.0 4.0 5.0	0.98 1.57 2.55	0.98 1.57 2.55 3.14	2.5 3.0 3.5 5.0	1.4 3.0 3.5 5.0
Travel (mm)		0.13	0.12 0.15	0.15 0.2	0.25		0.7 0.71 0.73 0.74	0.7 0.8 0.9 1.04
Operating temperature range		-40°C to +85°C	-30°C to +85°C -40°C to +90°C	-40°C to +90°C				
Electrical performance	Rating (max.)	50mA 12V DC	25mA 12V DC 25mA 16V DC 50mA 16V DC	50mA 16V DC	50mA 12V DC		50mA 16V DC	50mA 12V DC 50mA 16V DC
	Rating (min.)	10μA 1V DC						
	Insulation resistance	100MΩ min. 100V DC for 1 min.						
	Voltage proof	250V AC for 1 min.	100V AC for 1 min. 250V AC for 1 min.	250V AC for 1 min.				100V AC for 1 min. 250V AC for 1 min.
Environmental performance	Cold	-40°C 96h	-40°C 96h -40°C 500h	-40°C 96h -40°C 1,000h	-40°C 96h		-40°C 1,000h	-40°C 96h -40°C 1,000h
	Dry heat	90°C 96h	90°C 96h 90°C 500h	90°C 96h 90°C 1,000h	90°C 96h		90°C 1,000h	90°C 96h 90°C 1,000h
	Damp heat	60°C, 90 to 95%RH 96h	60°C, 90 to 95%RH 96h 60°C, 90 to 95%RH 500h	60°C, 90 to 95%RH 96h 60°C, 90 to 95%RH 1,000h	60°C, 90 to 95%RH 96h		60°C, 90 to 95%RH 1,000h	60°C, 90 to 95%RH 96h 60°C, 90 to 95%RH 1,000h
Automotive		—	●	○	●	●	●	○

 Note

● Indicates applicability to all products in the series, while ○ indicates applicability to some products in the series.

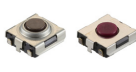





Surface Mount Type

Series		SKTR	SKTT	SKRA	SKHM	SKHU	SKST	SKTD
Photo								
Operation feeling		Sharp feeling						
Water-proof		—	—	○	—	—	—	●
Dust-proof		●	—	○	—	○	—	●
IP standard		IP6X equivalent	—	IP6X equivalent/ IPX7	—	—	—	IP6X equivalent/ IPX7
Operating direction	Top push	●	●	●	●	●	●	—
	Side push	—	—	—	—	—	—	●
Ground terminal		—	—	—	—	○	—	—
Dimensions (mm)		6.1×6.1×4.1	6.2×6.2×4.4	6.2×6.2×3.4 6.2×6.2×3.5 6.2×6.2×5.2	6.2×6.5×3.1	6.2×6.3×2.5 6.2×6.3×3.1	8.5×8.5×3.95	3.9×2.9×1.55
Operating force (N)		3.0 3.8 4.0	4.0	0.6 1.2 1.96 2.0 2.45 3.43 3.92	0.98 1.57 2.35	0.98 1.57 2.55	4.0 4.5 7.0 10.0	1.6 2.0
Travel (mm)		0.72 0.75 0.78	0.36	0.25 0.3 0.35 0.4 0.5 0.55	0.25		0.75 0.9	0.15
Operating temperature range		-40°C to +90°C			-40°C to +85°C		-40°C to +90°C	-30°C to +85°C
Electrical performance	Rating (max.)	50mA 16V DC		50mA 12V DC 50mA 16V DC	50mA 12V DC		50mA 16V DC	50mA 12V DC
	Rating (min.)	10μA 1V DC						
	Insulation resistance	100MΩ min. 100V DC for 1 min.						
	Voltage proof	250V AC for 1 min.						100V AC for 1 min.
Environmental performance	Cold	-40°C 1,000h		-40°C 96h -40°C 1,000h	-40°C 96h		-40°C 1,000h	-40°C 96h
	Dry heat	90°C 1,000h		90°C 96h 90°C 1,000h	90°C 96h		90°C 1,000h	85°C 96h
	Damp heat	60°C, 90 to 95%RH 1,000h		60°C, 90 to 95%RH 96h 60°C, 90 to 95%RH 1,000h	60°C, 90 to 95%RH 96h		60°C, 90 to 95%RH 1,000h	60°C, 90 to 95%RH 96h
Automotive		●	●	○	—	●	●	—

 Note

● Indicates applicability to all products in the series, while ○ indicates applicability to some products in the series.

Surface Mount Type

Series		SKSN	SKSL	SKSC	SKRT	SKSJ	SKPS	SKPM	
Photo									
Operation feeling		Sharp feeling					Soft feeling		
Water-proof		—	—	—	—	—	—	—	
Dust-proof		—	—	—	—	—	—	—	
IP standard		—	—	—	—	—	—	—	
Operating direction	Top push	—	—	—	—	—	●	●	
	Side push	●	●	●	●	●	—	—	
Ground terminal		—	—	○	—	—	—	—	
Dimensions (mm)		6.2×3.0×3.5 7.5×3.0×3.5 7.5×4.07×3.5	4.5×2.6×2.2	3.5×3.55×1.25	4.5×3.4×3.3	4.8×3.25×3.3	5.9×6.0×5.0		
Operating force (N)		1.6 2.4 4.5 5.0	1.6 2.2 3.5	1.6 2.2	1.6		2.5 3.0 3.3 3.6	1.57 1.96 2.45 3.0	
Travel (mm)		0.15 0.2 0.23	0.15	0.2		1.05		1.3	
Operating temperature range		-40°C to +85°C -40°C to +90°C	-30°C to +85°C		-40°C to +90°C	-30°C to +85°C	-40°C to +90°C		
Electrical performance	Rating (max.)	50mA 12V DC 50mA 16V DC		50mA 12V DC			50mA 16V DC		
	Rating (min.)	10μA 1V DC							
	Insulation resistance	100MΩ min. 100V DC for 1 min. 100MΩ min. 500V DC for 1 min.	100MΩ min. 100V DC for 1 min.						
	Voltage proof	100V AC for 1 min. 250V AC for 1 min.	250V AC for 1 min.	100V AC for 1 min.	250V AC for 1 min.	100V AC for 1 min.	250V AC for 1 min.		
Environmental performance	Cold	-40°C 96h -40°C 1,000h		-40°C 96h		-30°C 96h	-40°C 1,000h		
	Dry heat	85°C 96h 90°C 96h 90°C 1,000h	85°C 96h 90°C 1,000h	90°C 96h		85°C 96h	90°C 1,000h		
	Damp heat	60°C, 90 to 95%RH 96h 60°C, 90 to 95%RH 1,000h		60°C, 90 to 95%RH 96h			60°C, 90 to 95%RH 1,000h		
Automotive		○	○	—	—	—	●	●	

 Note

● Indicates applicability to all products in the series, while ○ indicates applicability to some products in the series.

Surface Mount Type

Series		SKPR
Photo		
Operation feeling		Soft feeling
Water-proof		—
Dust-proof		—
IP standard		—
Operating direction	Top push	●
	Side push	—
Ground terminal		—
Dimensions (mm)		7.5×7.8×6.5
Operating force (N)		5.0
Travel (mm)		1.0
Operating temperature range		-40°C to +90°C
Electrical performance	Rating (max.)	50mA 16V DC
	Rating (min.)	10μA 1V DC
	Insulation resistance	100MΩ min. 100V DC for 1 min.
	Voltage proof	250V AC for 1 min.
Environmental performance	Cold	-40°C 1,000h
	Dry heat	90°C 1,000h
	Damp heat	60°C, 90 to 95%RH 1,000h
Automotive		●

Note

● Indicates applicability to all products in the series, while ○ indicates applicability to some products in the series.

TACT Switch™ Surface Mount Type

3.7mm Square (Surface Mount) SKRW Series

Compact, thin-profile type with a height of 0.35mm.

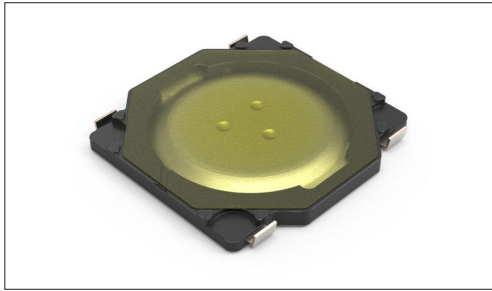

- Series type: Sharp feeling type
- Absolute Maximum Ratings: 50mA 12V DC
- Rating (min.): 10μA 1V DC

Applications: Mobile: Headsets, wearables, Notebooks, peripherals
Audio_TV: Visual, Audio, Cameras

Product List

Products No.	Operating direction	Operating force (N)	Travel (mm)	Operating life (cycles)	Initial contact resistance	Dimensions (WxDxH) (mm)	Water-proof	Dust-proof	Automotive	Drawing No.
SKRWAE030	Top push	1.57	0.15	500,000	100mΩ max.	3.7×3.7×0.35	—	—	—	1
SKRWAE030	Top push	2.35	0.15	50,000	100mΩ max.	3.7×3.7×0.35	—	—	—	
SKRWAME030	Top push	1.57	0.15	1,000,000	100mΩ max.	3.7×3.7×0.35	—	—	—	
SKRWANE030	Top push	1.27	0.15	1,000,000	100mΩ max.	3.7×3.7×0.35	—	—	—	

Note

1. This catalog shows only outline specifications. When using the products, please obtain formal specifications for supply.
2. Please place purchase orders for taping products per minimum order unit (1 reel or a case).

Packing Specifications

Taping

Number of packages (pcs.)			Tape width (mm)	Export package measurements (mm)
1 reel	1 case / Japan	1 case / export packing		
10,000	100,000	100,000	12	395 x 395 x 205

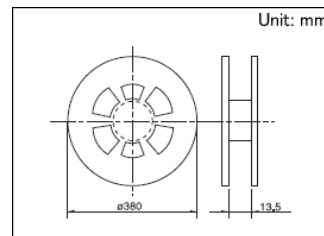

Drawing No.1

Dimensions

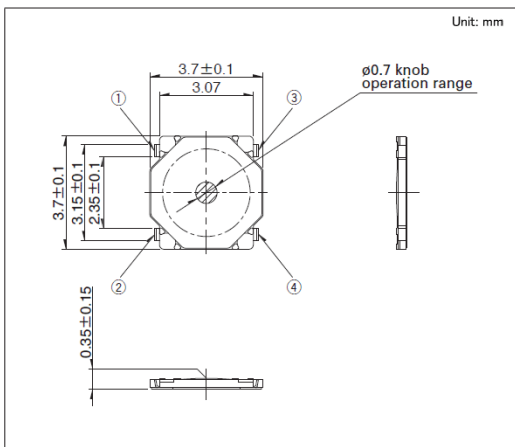

Land Dimensions

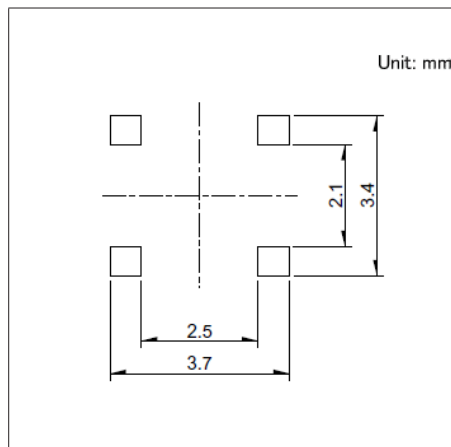

Circuit Diagram

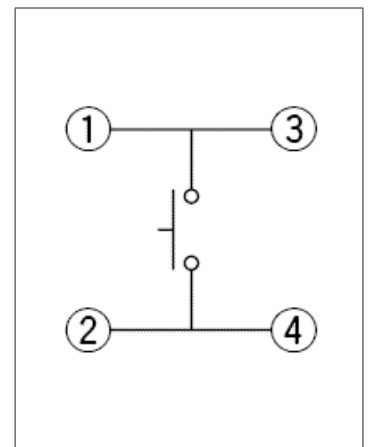

Viewed from mounting face.

TACT Switch™ Surface Mount Type

4.5mm Square (Surface Mount) SKRM Series

Compact, thin-profile type with a height of 0.4mm.



- Series type: Sharp feeling type
- Absolute Maximum Ratings: 50mA 12V DC
- Rating (min.): 10μA 1V DC

Applications: Mobile: Headsets, wearables, Notebooks, peripherals

Product List

Products No.	Operating direction	Operating force (N)	Travel (mm)	Operating life (cycles)	Initial contact resistance	Dimensions (W×D×H) (mm)	Water-proof	Dust-proof	Automotive	Drawing No.
SKRMAAE010	Top push	1.57	0.15	500,000	100mΩ max.	4.5×4.5×0.4	—	—	—	1
SKRMABE010	Top push	2.55	0.2	100,000	100mΩ max.	4.5×4.5×0.4	—	—	—	

⚠ Note

1. This catalog shows only outline specifications. When using the products, please obtain formal specifications for supply.
2. Please place purchase orders for taping products per minimum order unit (1 reel or a case).

Packing Specifications

Taping

Number of packages (pcs.)			Tape width (mm)	Export package measurements (mm)
1 reel	1 case / Japan	1 case / export packing		
10,000	100,000	100,000	12	395 x 395 x 205

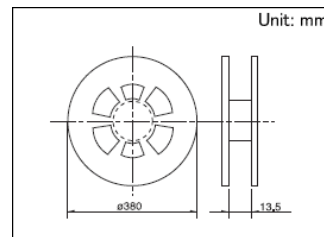

Drawing No.1

Dimensions

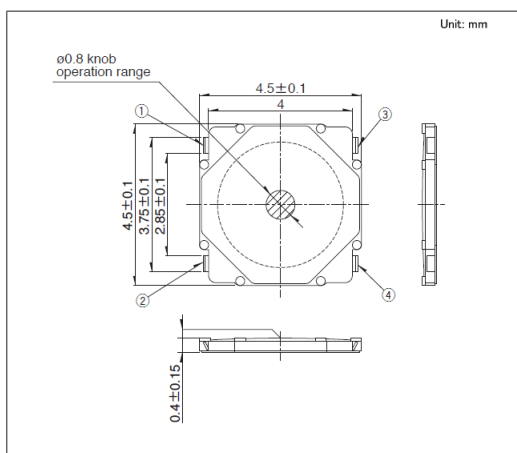

Land Dimensions

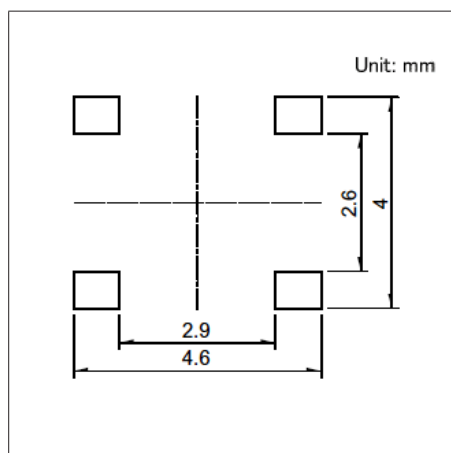

Circuit Diagram

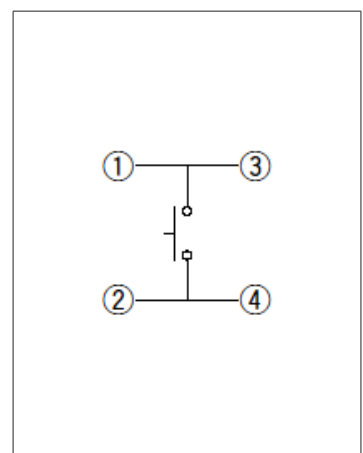

Viewed from mounting face.

TACT Switch™ Surface Mount Type

4.8mm Square (Surface Mount)

SKRB Series

Automotive-compatible compact, thin-profile type with a height of 0.55mm.



- Series type: Sharp feeling type
- Absolute Maximum Ratings: 50mA 12V DC
- Rating (min.): 10μA 1V DC

Applications: Home: Major home appliances, Office equipment
 Automotive: Remote Keyless Entry (RKE), Navigation/audio systems, HVAC, Overhead consoles, Steering, Shifter

■ Product List

Products No.	Operating direction	Operating force (N)	Travel (mm)	Operating life (cycles)	Initial contact resistance	Dimensions (W×D×H) (mm)	Water-proof	Dust-proof	Automotive	Drawing No.
SKRBAGE010	Top push	1.1	0.15	2,000,000	100mΩ max.	4.8×4.8×0.55	—	—	●	1
SKRBAAE010	Top push	1.57	0.2	1,000,000	100mΩ max.	4.8×4.8×0.55	—	—	●	
SKRBACE010	Top push	2.55	0.2	500,000	100mΩ max.	4.8×4.8×0.55	—	—	●	
SKRBAKE010	Top push	3.5	0.2	200,000	100mΩ max.	4.8×4.8×0.55	—	—	●	

Note

1. This catalog shows only outline specifications. When using the products, please obtain formal specifications for supply.
2. Please place purchase orders for taping products per minimum order unit (1 reel or a case).

■ Packing Specifications

Taping

Number of packages (pcs.)			Tape width (mm)	Export package measurements (mm)
1 reel	1 case / Japan	1 case / export packing		
10,000	100,000	100,000	12	395 x 395 x 205

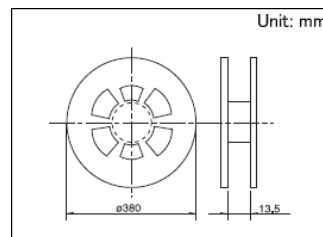

Drawing No.1

■ Dimensions

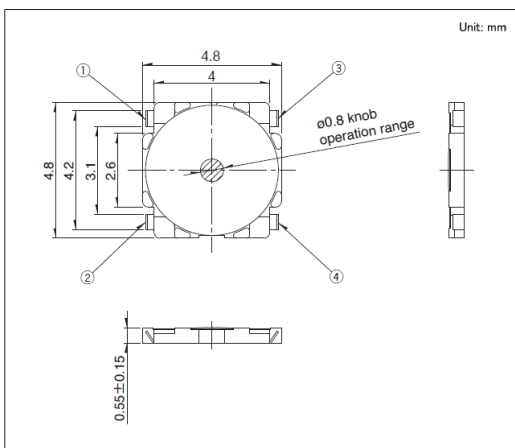

■ Land Dimensions

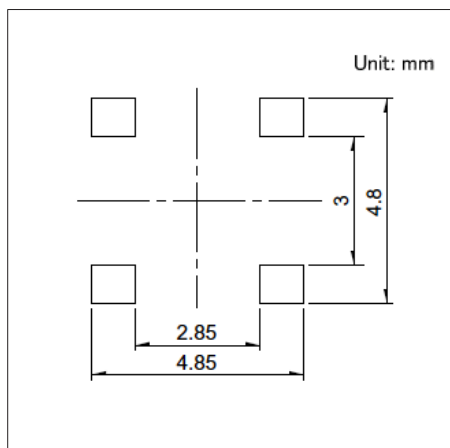

■ Circuit Diagram

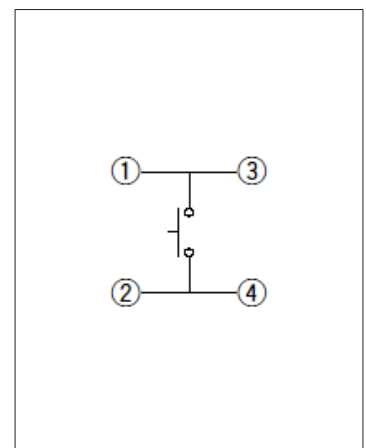

Viewed from mounting face.

TACT Switch™ Surface Mount Type

7.5×7.0mm (Surface Mount)

SKRR Series

Long-life type with a height of 0.6mm, capable of 5 million operations.



- Series type: Sharp feeling type
- Absolute Maximum Ratings: 50mA 12V DC
- Rating (min.): 10μA 1V DC

Applications: Game: Home handheld consoles, Virtual/augmented reality

Product List

Products No.	Operating direction	Operating force (N)	Travel (mm)	Operating life (cycles)	Initial contact resistance	Dimensions (W×D×H) (mm)	Water-proof	Dust-proof	Automotive	Drawing No.
SKRRAAE010	Top push	1.0	0.25	5,000,000	500mΩ max.	7.5×7.0×0.6	—	—	—	1
SKRRABE010	Top push	1.6	0.25	5,000,000	500mΩ max.	7.5×7.0×0.6	—	—	—	
SKRRACE010	Top push	2.0	0.25	5,000,000	500mΩ max.	7.5×7.0×0.6	—	—	—	

⚠ Note

1. This catalog shows only outline specifications. When using the products, please obtain formal specifications for supply.
2. Please place purchase orders for taping products per minimum order unit (1 reel or a case).

Packing Specifications

Taping

Number of packages (pcs.)			Tape width (mm)	Export package measurements (mm)
1 reel	1 case / Japan	1 case / export packing		
7,000	56,000	56,000	16	395 x 395 x 205

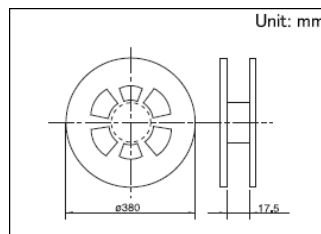

Drawing No. 1

Dimensions

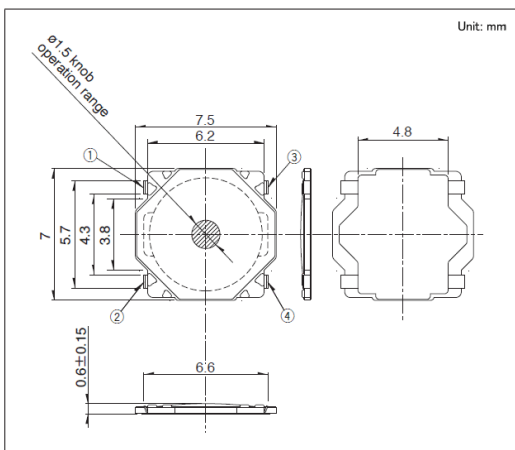

Land Dimensions

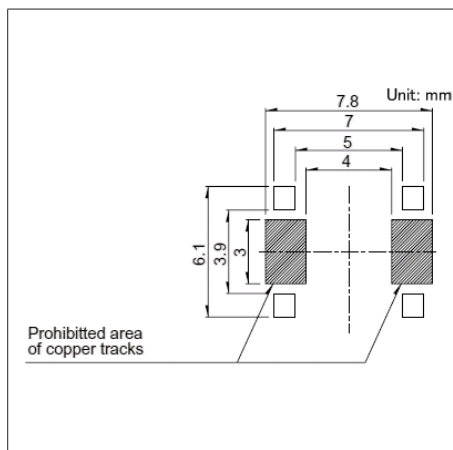

Circuit Diagram

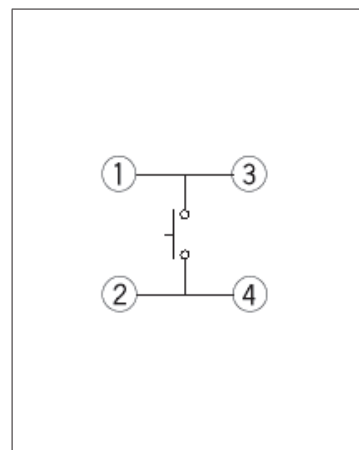

Viewed from mounting face.

TACT Switch™ Surface Mount Type

5.2mm Square (Surface Mount) SKQG Series

Automotive-compatible compact, thin-profile type with a height of 1.5mm.

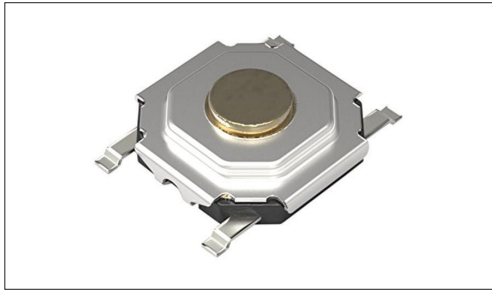

- Series type: Sharp feeling type
- Absolute Maximum Ratings: 50mA 12V DC
- Rating (min.): 10μA 1V DC

Applications: Mobile: Notebooks, peripherals
 Healthcare: Healthcare equipment
 Automotive: Remote Keyless Entry (RKE), Navigation/audio systems, HVAC, Overhead consoles, Steering, Shifter

Product List

Products No.	Operating direction	Operating force (N)	Travel (mm)	Operating life (cycles)	Initial contact resistance	Dimensions (W×D×H) (mm)	Water-proof	Dust-proof	Automotive	Drawing No.
SKQGAFE010	Top push	0.98	0.25	500,000	100mΩ max.	5.2 x 5.2×1.5	—	—	●	1
SKQGABE010	Top push	1.57	0.25	1,000,000	100mΩ max.	5.2 x 5.2×1.5	—	—	●	
SKQGAD E010	Top push	2.55	0.25	100,000	100mΩ max.	5.2 x 5.2×1.5	—	—	●	
SKQGAKE020	Top push	3.43	0.25	100,000	100mΩ max.	5.2 x 5.2×1.5	—	—	●	

Note

1. This catalog shows only outline specifications. When using the products, please obtain formal specifications for supply.
2. Please place purchase orders for taping products per minimum order unit (1 reel or a case).

Packing Specifications

Taping

Number of packages (pcs.)			Tape width (mm)	Export package measurements (mm)
1 reel	1 case / Japan	1 case / export packing		
4,000	40,000	40,000	12	395 x 395 x 205

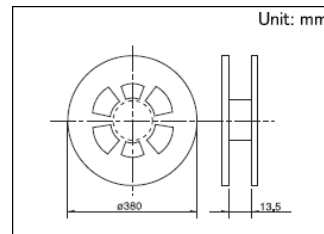

Drawing No. 1

Dimensions

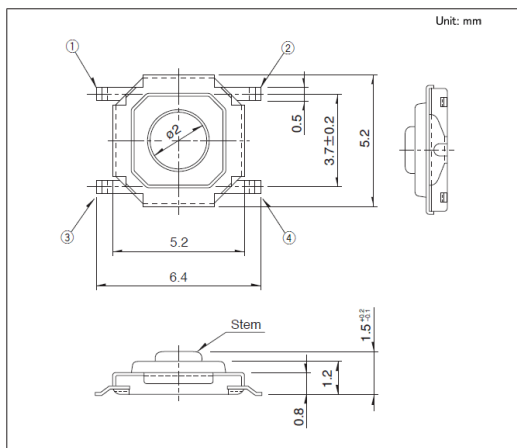

Land Dimensions

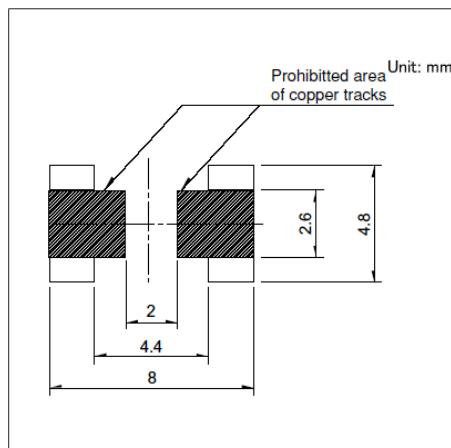

Circuit Diagram

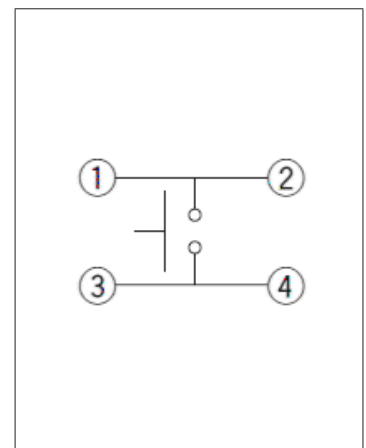

Viewed from mounting face.

TACT Switch™ Surface Mount Type

4.1×3.9mm Double Action Type (Surface Mount)

SKSD Series

Compact, thin-profile double-action type with a height of 0.6mm.



- Series type: Sharp feeling type
- Absolute Maximum Ratings: 50mA 12V DC
- Rating (min.): 10μA 1V DC

Applications: Audio_TV:Cameras

Product List

Products No.	Operating direction	Operating force (N)	Travel (mm)	Operating life (cycles)	Initial contact resistance	Dimensions (W×D×H) (mm)	Water-proof	Dust-proof	Automotive	Drawing No.
SKSDPBE010	Top push	1st 0.8, 2nd 1.6	1st 0.15, All 0.25	100,000	200mΩ max.	4.1×3.9×0.6	—	—	—	1
SKSDPCE010	Top push	1st 0.8, 2nd 1.9	1st 0.15, All 0.25	50,000	200mΩ max.	4.1×3.9×0.6	—	—	—	

Note

1. This catalog shows only outline specifications. When using the products, please obtain formal specifications for supply.
2. Please place purchase orders for taping products per minimum order unit (1 reel or a case).

Packing Specifications

Taping

Number of packages (pcs.)			Tape width (mm)	Export package measurements (mm)
1 reel	1 case / Japan	1 case / export packing		
10,000	100,000	100,000	12	395 x 395 x 205

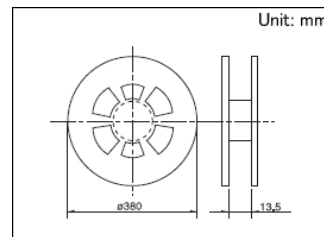

Drawing No. 1

Dimensions

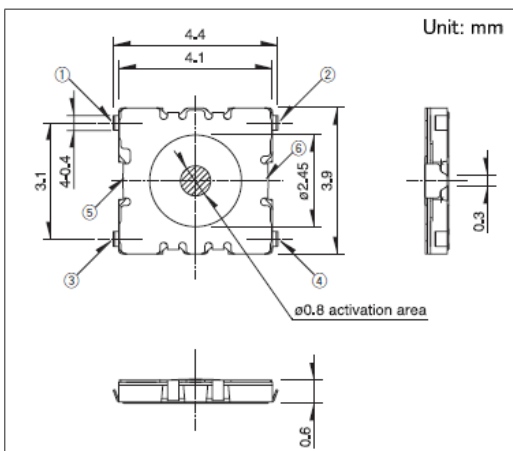

Land Dimensions

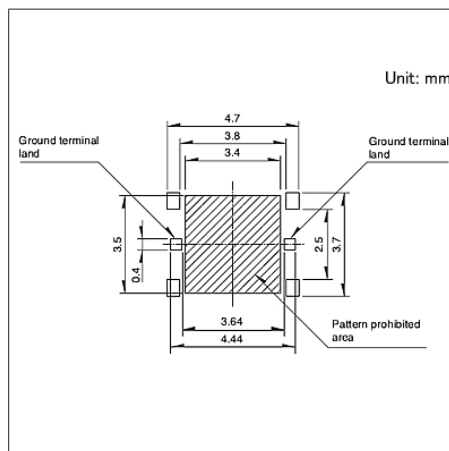

Viewed from mounting face.

Circuit Arrangement

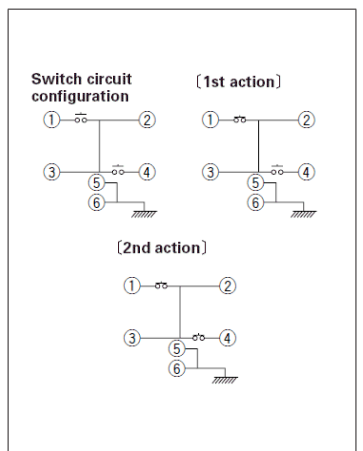

TACT Switch™ Surface Mount Type

6.0mm Square Double Action Type (Surface Mount)

SKRN Series

Thin-profile double-action type with a height of 0.9mm.

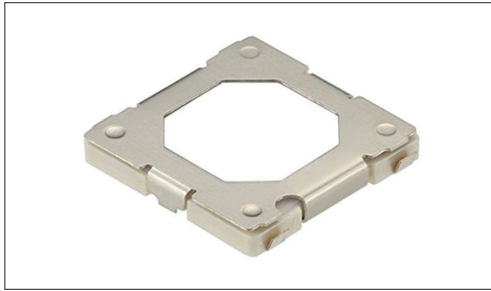

- Series type: Sharp feeling type
- Absolute Maximum Ratings: 50mA 12V DC
- Rating (min.): 10 μ A 1V DC

Applications: Audio_TV:Cameras

Product List

Products No.	Operating direction	Operating force (N)	Travel (mm)	Operating life (cycles)	Initial contact resistance	Guide bosses	Dimensions (W×D×H) (mm)	Water-proof	Dust-proof	Automotive	Drawing No.
SKRNPAE010	Top push	1st 0.78, 2nd 2.45	1st 0.25, All 0.4	30,000	100m Ω max.	Without	6.0×6.0×0.9	—	—	—	1
SKRNPBE010	Top push	1st 0.78, 2nd 2.45	1st 0.25, All 0.4	30,000	100m Ω max.	With	6.0×6.0×0.9	—	—	—	
SKRNPCE010	Top push	1st 0.78, 2nd 1.57	1st 0.25, All 0.4	30,000	100m Ω max.	With	6.0×6.0×0.9	—	—	—	
SKRNPDE010	Top push	1st 0.78, 2nd 1.57	1st 0.25, All 0.4	30,000	100m Ω max.	Without	6.0×6.0×0.9	—	—	—	
SKRNPEE010	Top push	1st 0.59, 2nd 1.57	1st 0.25, All 0.4	100,000	100m Ω max.	Without	6.0×6.0×0.9	—	—	—	
SKRNPME010	Top push	1st 0.59, 2nd 1.57	1st 0.25, All 0.4	100,000	100m Ω max.	With	6.0×6.0×0.9	—	—	—	

⚠ Note

1. This catalog shows only outline specifications. When using the products, please obtain formal specifications for supply.
2. Please place purchase orders for taping products per minimum order unit (1 reel or a case).

Packing Specifications

Taping

Number of packages (pcs.)			Tape width (mm)	Export package measurements (mm)
1 reel	1 case / Japan	1 case / export packing		
5,000	50,000	50,000	12	395 x 395 x 205

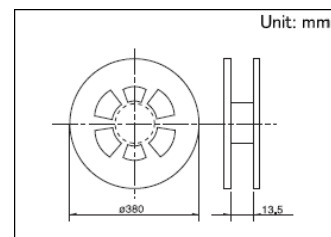

TACT Switch™ Surface Mount Type

6.0mm Square Double Action Type (Surface Mount)

SKRN Series

Drawing No.1

■ Dimensions

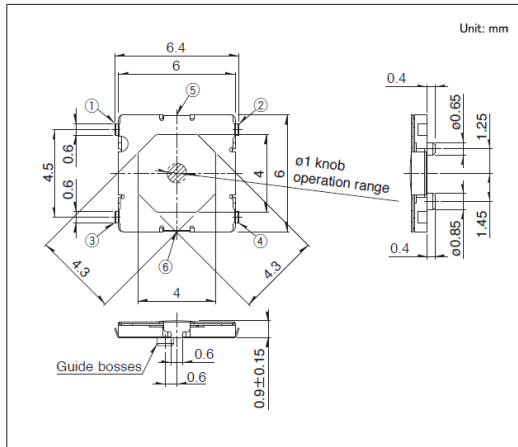

■ Land Dimensions

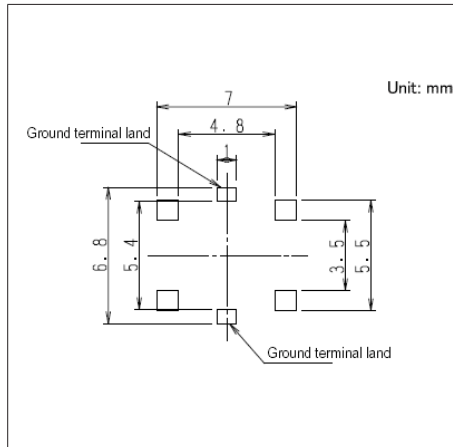

■ Circuit Arrangement

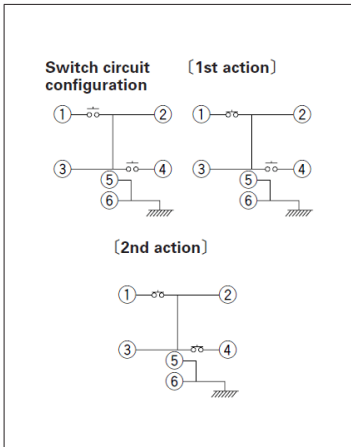

Viewed from mounting face.

TACT Switch™ Surface Mount Type

2.4×1.4mm Compact Type with Projection (Surface Mount)

SKUB Series

Compact, thin-profile type with a height of 0.55mm, compliant with IP6X equivalent/IPX8.

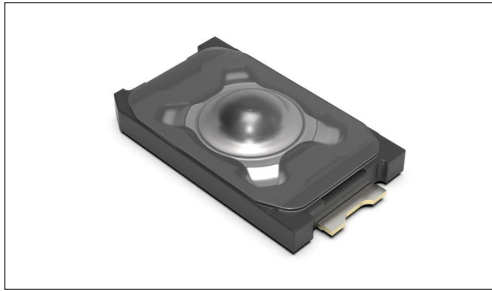

Water-proof Type

Dust-proof Type

- Series type: Sharp feeling type
- Absolute Maximum Ratings: 50mA 12V DC
- Rating (min.): 10μA 1V DC

Applications: Mobile: Smartphones, tablets, Headsets, wearables

■ Product List

Products No.	Operating direction	Operating force (N)	Travel (mm)	Operating life (cycles)	Initial contact resistance	Dimensions (W×D×H) (mm)	Water-proof	Dust-proof	Water-proof & Dust-proof	Automotive	Drawing No.
SKUBAAE010	Top push	1.6	0.11	500,000	500mΩ max.	2.4×1.4×0.55	●	●	IP6X equivalent/IPX8	—	1

Note

1. This catalog shows only outline specifications. When using the products, please obtain formal specifications for supply.
2. Please place purchase orders for taping products per minimum order unit (1 reel or a case).
3. Protective structure :
Assumes the switch is left alone without being operated. Under the specified conditions, dust and water ingress with a significant impact on the switch's on-off function is prevented.
IP6X equivalent/IPX8 dust and water resistance is guaranteed for the switch alone and performance may not be guaranteed depending on the mounting conditions and usage.

■ Packing Specifications

Taping

Number of packages (pcs.)			Tape width (mm)	Export package measurements (mm)
1 reel	1 case / Japan	1 case / export packing		
20,000	200,000	200,000	12	395 x 395 x 205

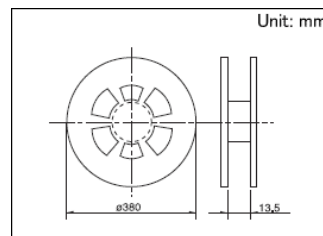

Drawing No.1

■ Dimensions

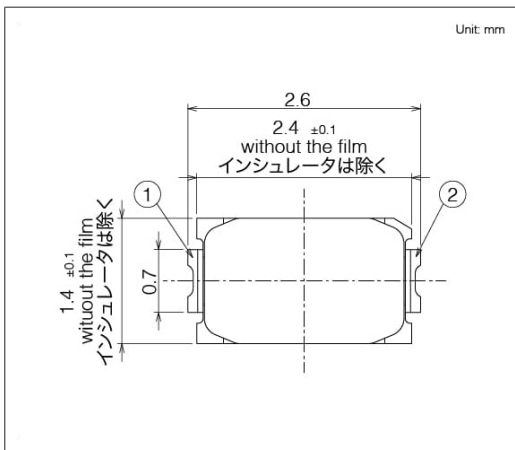

■ Land Dimensions

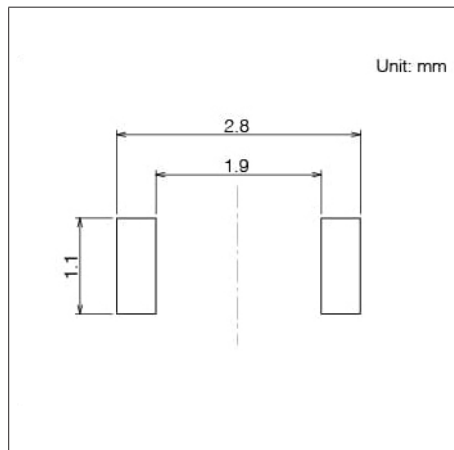

■ Circuit Diagram

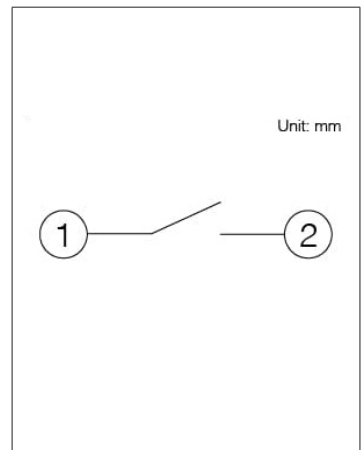

Viewed from mounting face.

TACT Switch™ Surface Mount Type

2.6×1.6mm Compact Type with Projection (Surface Mount)

SKTA Series

Compact, thin-profile type with a height of 0.53mm, compliant with IP6X equivalent/IPX7.



Water-proof Type

Dust-proof Type

- Series type: Sharp feeling type
- Absolute Maximum Ratings: 50mA 12V DC
- Rating (min.): 10μA 1V DC

Applications: Mobile: Smartphones, tablets, Headsets, wearables

■ Product List

Products No.	Operating direction	Operating force (N)	Travel (mm)	Operating life (cycles)	Initial contact resistance	Dimensions (W×D×H) (mm)	Water-proof	Dust-proof	Water-proof & Dust-proof	Automotive	Drawing No.
SKTAACE010	Top push	1.0	0.11	300,000	500mΩ max.	2.6×1.6×0.53	●	●	IP6X equivalent/IPX7	—	1
SKTAAAE010	Top push	1.6	0.11	300,000	500mΩ max.	2.6×1.6×0.53	●	●	IP6X equivalent/IPX7	—	

Note

1. This catalog shows only outline specifications. When using the products, please obtain formal specifications for supply.
2. Please place purchase orders for taping products per minimum order unit (1 reel or a case).
3. Protective structure :
Assumes the switch is left alone without being operated. Under the specified conditions, dust and water ingress with a significant impact on the switch's on-off function is prevented.
IP6X equivalent/IPX7 dust and water resistance is guaranteed for the switch alone and performance may not be guaranteed depending on the mounting conditions and usage.

■ Packing Specifications

Taping

Number of packages (pcs.)			Tape width (mm)	Export package measurements (mm)
1 reel	1 case / Japan	1 case / export packing		
20,000	20,000	20,000	12	395 x 395 x 205

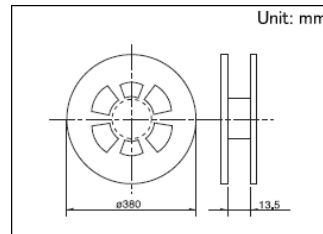

Drawing No. 1

■ Dimensions

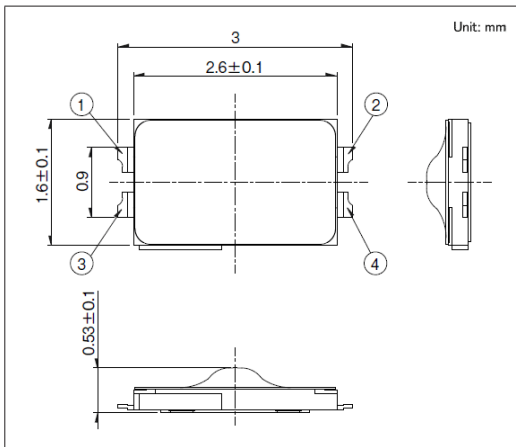

■ Land Dimensions

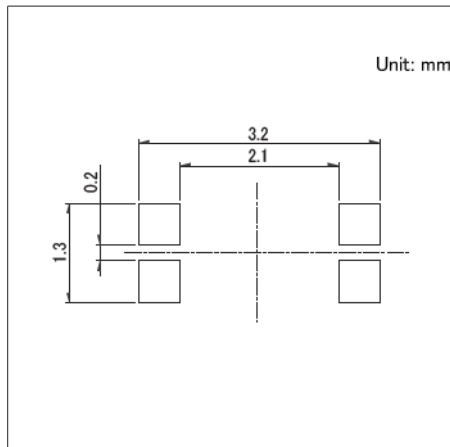

■ Circuit Diagram

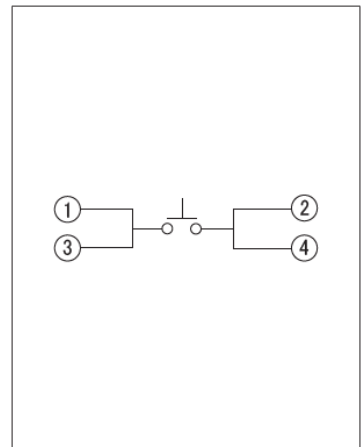

Viewed from mounting face.

TACT Switch™ Surface Mount Type

2.8×1.9mm Compact Type with Projection (Surface Mount)

SKSV Series

Compact, thin-profile type with a height of 0.5mm, compliant with IP6X equivalent/IPX7.

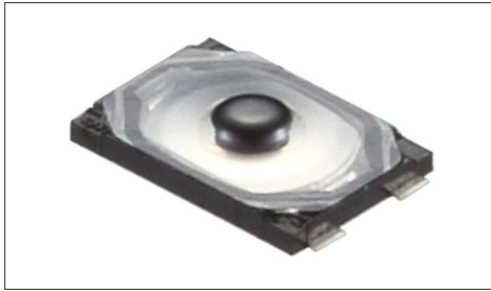

 Water-proof Type

 Dust-proof Type

- Series type: Sharp feeling type
- Absolute Maximum Ratings: 50mA 12V DC
- Rating (min.): 10μA 1V DC

Applications: Mobile: Smartphones, tablets, Headsets, wearables
 Healthcare: Healthcare equipment
 Audio_TV: Audio, Cameras
 Game: Home handheld consoles, Virtual/augmented reality

■ Product List

Products No.	Operating direction	Operating force (N)	Travel (mm)	Operating life (cycles)	Initial contact resistance	Dimensions (W×D×H) (mm)	Water-proof	Dust-proof	Water-proof & Dust-proof	Automotive	Drawing No.
SKSVCBE010	Top push	1.0	0.12	300,000	500mΩ max.	2.8×1.9×0.55	●	●	IP6X equivalent/IPX7	—	1
SKSVCAE010	Top push	1.6	0.12	300,000	500mΩ max.	2.8×1.9×0.5	●	●	IP6X equivalent/IPX7	—	2
SKSVCCE010	Top push	2.2	0.12	100,000	500mΩ max.	2.8×1.9×0.5	●	●	IP6X equivalent/IPX7	—	

Note

1. This catalog shows only outline specifications. When using the products, please obtain formal specifications for supply.
2. Please place purchase orders for taping products per minimum order unit (1 reel or a case).
3. Protective structure :
 Assumes the switch is left alone without being operated. Under the specified conditions, dust and water ingress with a significant impact on the switch's on-off function is prevented.
 IP6X equivalent/IPX7 dust and water resistance is guaranteed for the switch alone and performance may not be guaranteed depending on the mounting conditions and usage.

■ Packing Specifications

Taping

Number of packages (pcs.)			Tape width (mm)	Export package measurements (mm)
1 reel	1 case / Japan	1 case / export packing		
20,000	200,000	200,000	12	395 x 395 x 205

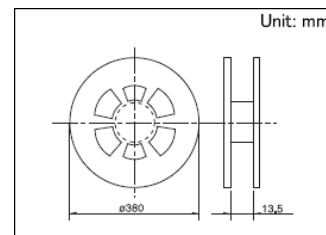

TACT Switch™ Surface Mount Type

2.8×1.9mm Compact Type with Projection (Surface Mount)
SKSV Series

Drawing No.1

■ Dimensions

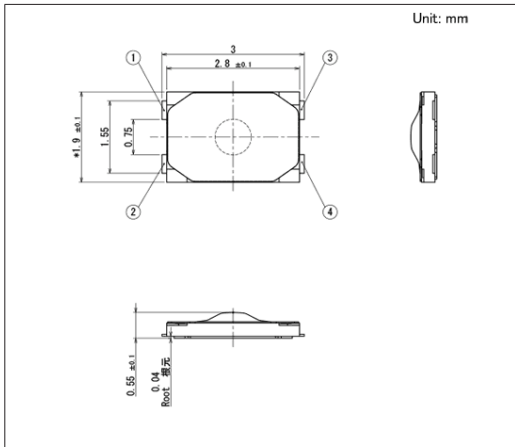

■ Land Dimensions

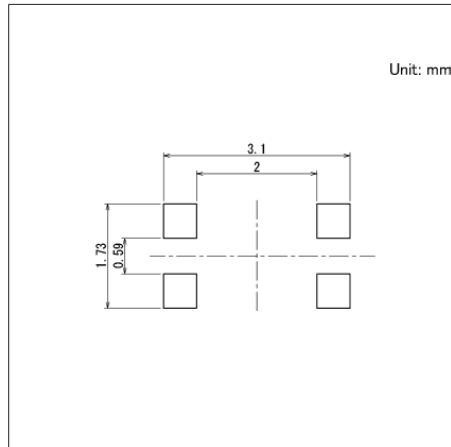

■ Circuit Diagram

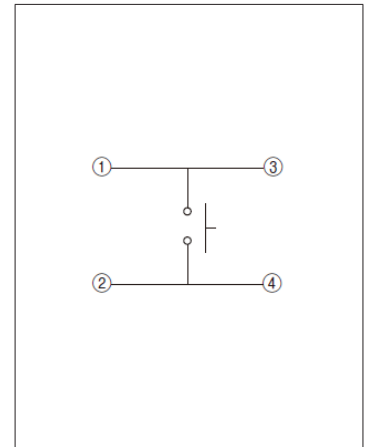

Viewed from mounting face.

Drawing No.2

■ Dimensions

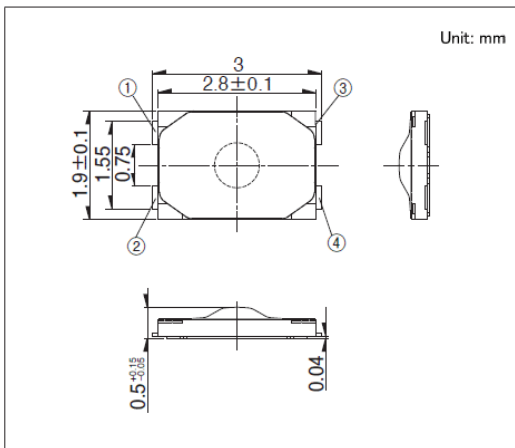

■ Land Dimensions

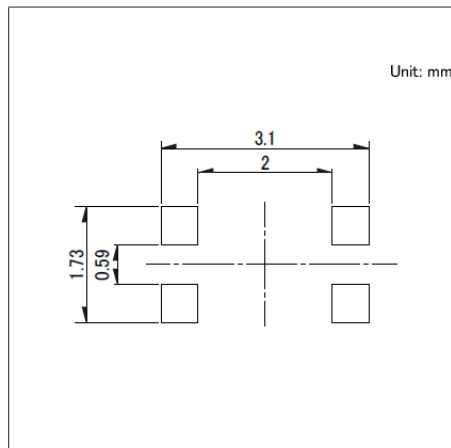

■ Circuit Diagram

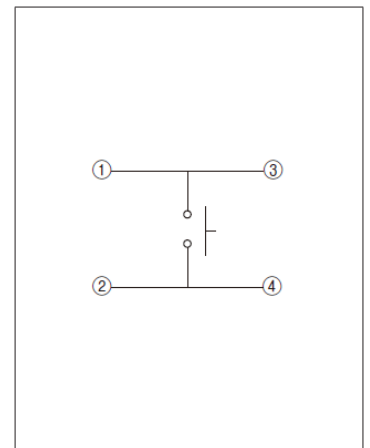

Viewed from mounting face.

TACT Switch™ Surface Mount Type

3.0×2.0mm Compact Type with Projection (Surface Mount)

SKSW Series

Compact, thin-profile type with a height of 0.6mm, compliant with IP6X equivalent/IPX7 (partially IPX8).

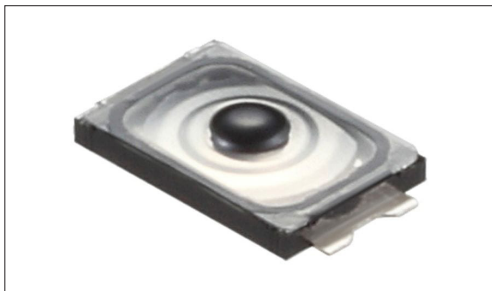

 Water-proof Type

 Dust-proof Type

- Series type: Sharp feeling type
- Absolute Maximum Ratings: 50mA 12V DC
- Rating (min.): 10μA 1V DC

Applications: Mobile: Smartphones, tablets, Headsets, wearables
 Game: Home handheld consoles, Virtual/augmented reality
 Audio_TV: Cameras

Product List

Products No.	Operating direction	Operating force (N)	Travel (mm)	Operating life (cycles)	Initial contact resistance	Dimensions (W×D×H) (mm)	Water-proof	Dust-proof	Water-proof & Dust-proof	Automotive	Drawing No.
SKSWCBE010	Top push	1.6	0.13	300,000	500mΩ max.	3.0×2.0×0.6	●	●	IP6X equivalent/IPX7	—	1
SKSWCEE010	Top push	1.8	0.13	300,000	500mΩ max.	3.0×2.0×0.6	●	●	IP6X equivalent/IPX7	—	
SKSWCFE010	Top push	2.4	0.13	500,000	500mΩ max.	3.0×2.0×0.6	●	●	IP6X equivalent/IPX7	—	
SKSWCGE010	Top push	3.3	0.13	300,000	500mΩ max.	3.0×2.0×0.6	●	●	IP6X equivalent/IPX7	—	
SKSWDAE010	Top push	2.4	0.13	300,000	500mΩ max.	3.0×2.0×0.6	●	●	IP6X equivalent/IPX8	—	2

Note

1. This catalog shows only outline specifications. When using the products, please obtain formal specifications for supply.
2. Please place purchase orders for taping products per minimum order unit (1 reel or a case).
3. Protective structure :
 Assumes the switch is left alone without being operated. Under the specified conditions, dust and water ingress with a significant impact on the switch's on-off function is prevented.
 IP6X equivalent/IPX7, or IP6X equivalent/IPX8, dust and water resistance is guaranteed for the switch alone and performance may not be guaranteed depending on the mounting conditions and usage.

Packing Specifications

Taping

Number of packages (pcs.)			Tape width (mm)	Export package measurements (mm)
1 reel	1 case / Japan	1 case / export packing		
20,000	200,000	200,000	12	395 x 395 x 205

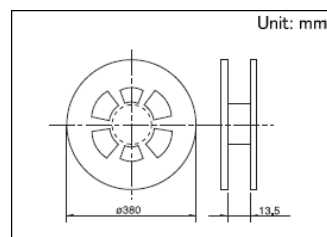

TACT Switch™ Surface Mount Type

3.0x2.0mm Compact Type with Projection (Surface Mount)

SKSW Series

Drawing No.1

■ Dimensions

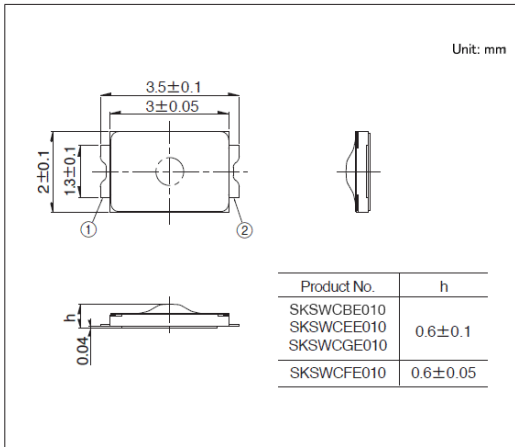

■ Land Dimensions

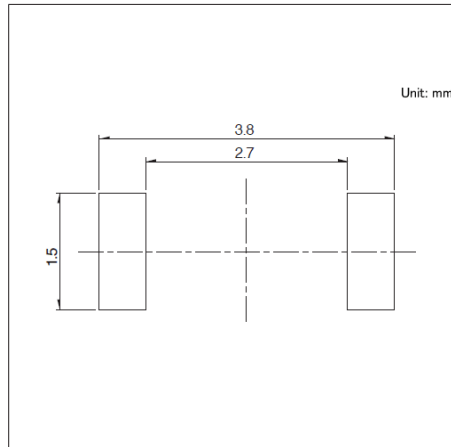

■ Circuit Diagram

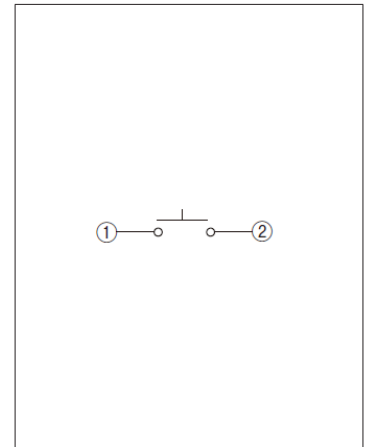

Viewed from mounting face.

Drawing No.2

■ Dimensions

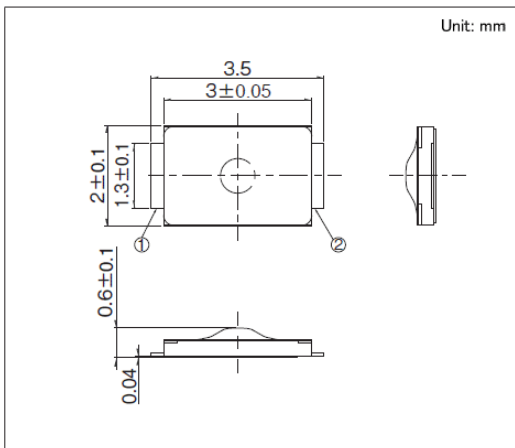

■ Land Dimensions

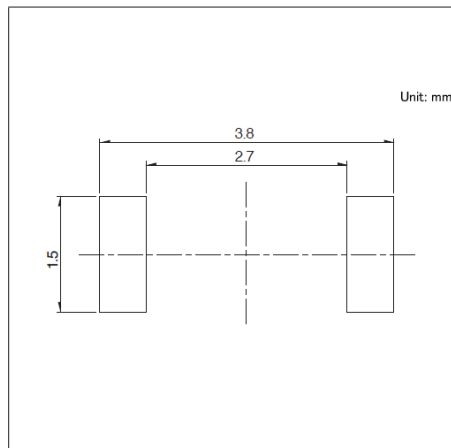

■ Circuit Diagram

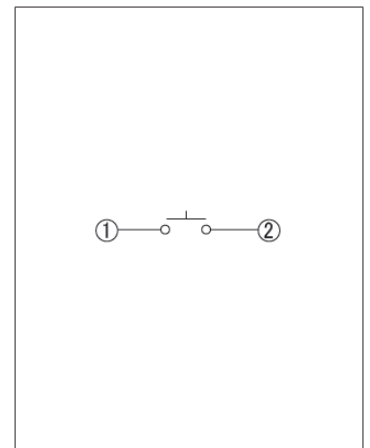

Viewed from mounting face.

TACT Switch™ Surface Mount Type

5.9×4.0mm with Projection (Surface Mount) SKTK Series

Long-life type with a height of 0.78mm, capable of 1 million operations, compliant with IP6X equivalent/IPX7.



Water-proof Type

Dust-proof Type

- Series type: Sharp feeling type
- Absolute Maximum Ratings: 50mA 12V DC
- Rating (min.): 10μA 1V DC

Applications: Mobile: Smartphones, tablets, Headsets, wearables, Notebooks, peripherals

Product List

Products No.	Operating direction	Operating force (N)	Travel (mm)	Operating life (cycles)	Initial contact resistance	Dimensions (W×D×H) (mm)	Water-proof	Dust-proof	Water-proof & Dust-proof	Automotive	Drawing No.
SKTKABE010	Top push	2.5	0.23	1,000,000	500mΩ max.	5.9×4.0×0.78	●	●	IP6X equivalent/IPX7	—	1

Note

1. This catalog shows only outline specifications. When using the products, please obtain formal specifications for supply.
2. Please place purchase orders for taping products per minimum order unit (1 reel or a case).
3. Protective structure :
Assumes the switch is left alone without being operated. Under the specified conditions, dust and water ingress with a significant impact on the switch's on-off function is prevented.
IP6X equivalent/IPX7 dust and water resistance is guaranteed for the switch alone and performance may not be guaranteed depending on the mounting conditions and usage.

Packing Specifications

Taping

Number of packages (pcs.)			Tape width (mm)	Export package measurements (mm)
1 reel	1 case / Japan	1 case / export packing		
10,000	80,000	80,000	16	395 x 395 x 205

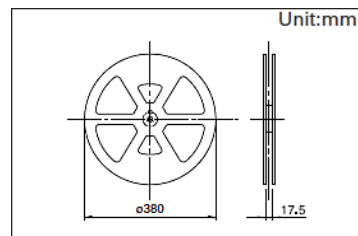

Drawing No. 1

Dimensions

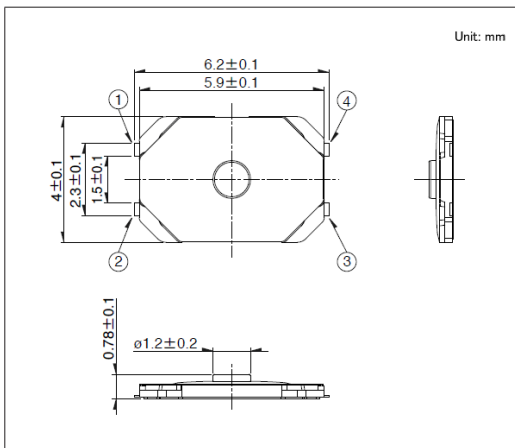

Land Dimensions

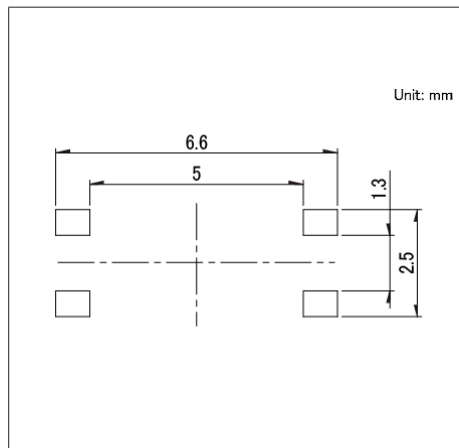

Circuit Diagram

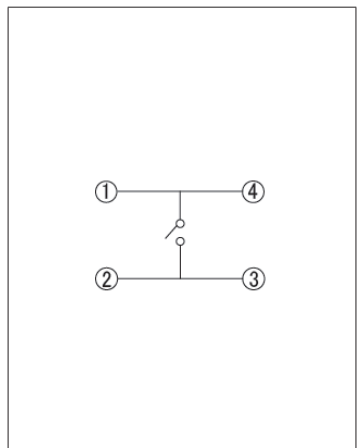

Viewed from switch mounting face

TACT Switch™ Surface Mount Type

7.0×7.5mm with Projection (Surface Mount)

SKUA Series

Long-life type with a height of 0.67mm, capable of 6 million operations, compliant with IP6X equivalent/IPX7.

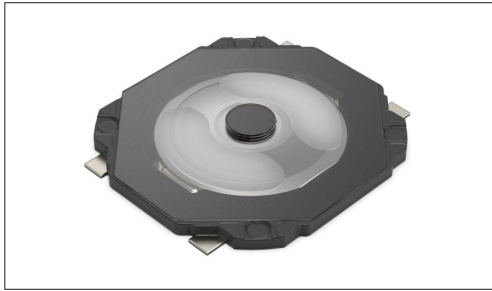

Water-proof Type

Dust-proof Type

- Series type: Sharp feeling type
- Absolute Maximum Ratings: 50mA 12V DC
- Rating (min.): 10μA 1V DC

Applications: Game: Home handheld consoles
Mobile: Smartphones, tablets, Notebooks, peripherals

■ Product List

Products No.	Operating direction	Operating force (N)	Travel (mm)	Operating life (cycles)	Initial contact resistance	Dimensions (W×D×H) (mm)	Water-proof	Dust-proof	Water-proof & Dust-proof	Automotive	Drawing No.
SKUAAE010	Top push	2.0	0.22	6,000,000	100mΩ max.	7.0×7.5×0.67	●	●	IP6X equivalent/IPX7	—	1

Note

1. This catalog shows only outline specifications. When using the products, please obtain formal specifications for supply.
2. Please place purchase orders for taping products per minimum order unit (1 reel or a case).
3. Protective structure :
Assumes the switch is left alone without being operated. Under the specified conditions, dust and water ingress with a significant impact on the switch's on-off function is prevented.
IP6X equivalent/IPX7 dust and water resistance is guaranteed for the switch alone and performance may not be guaranteed depending on the mounting conditions and usage.

■ Packing Specifications

Taping

Number of packages (pcs.)			Tape width (mm)	Export package measurements (mm)
1 reel	1 case / Japan	1 case / export packing		
6,800	54,400	54,400	16	395 x 395 x 205

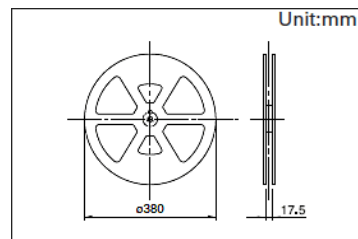

Drawing No. 1

■ Dimensions

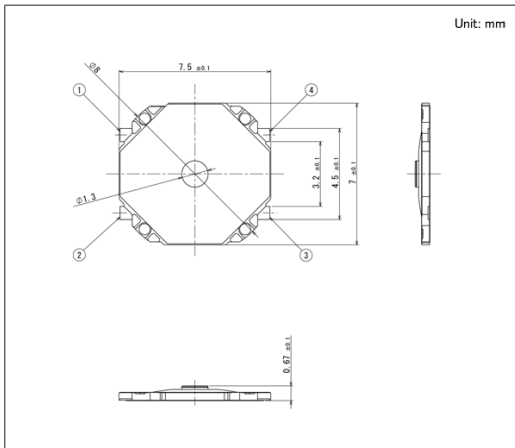

■ Land Dimensions

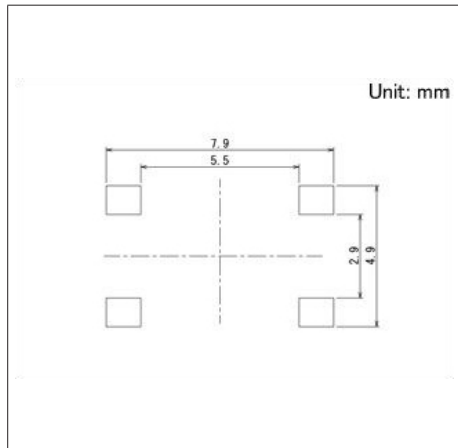

■ Circuit Diagram

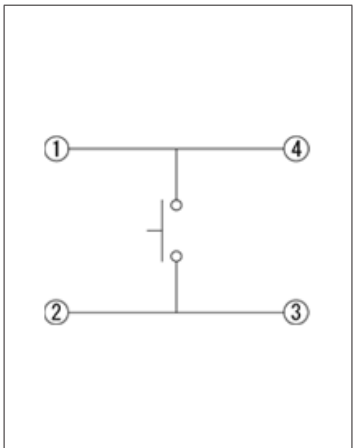

Viewed from switch mounting face

TACT Switch™ Surface Mount Type

3.0×2.7mm (Surface Mount)

SKSG Series

Compact short-stroke type with a height of 1.4mm, 0.12mm travel, automotive-compatible, with ground terminal options.



 Automotive

- Series type: Sharp feeling type
- Absolute Maximum Ratings: 50mA 12V DC
- Rating (min.): 10μA 1V DC

Applications: Mobile: Notebooks, peripherals
 Energy_Industrial: Robots, drones, Industrial equipment, Converters
 Game: Home handheld consoles, Virtual/augmented reality
 Automotive: Remote Keyless Entry (RKE), Navigation/audio systems, HVAC, Overhead consoles, Steering, Shifter

Product List

Products No.	Type	Operating direction	Operating force (N)	Travel (mm)	Operating life (cycles)	Initial contact resistance	Dimensions (W×D×H) (mm)	Water-proof	Dust-proof	Automotive	Drawing No.
SKSGACE010	Top push type	Top push	1.6	0.12	200,000	100mΩ max.	3.0×2.7×1.4	—	—	●	1
SKSGAFE010		Top push	2.8	0.12	200,000	100mΩ max.	3.0×2.7×1.4	—	—	●	
SKSGAAE010		Top push	4.0	0.12	200,000	100mΩ max.	3.0×2.7×1.4	—	—	●	
SKSGPCE010	With ground terminal type	Top push	1.6	0.12	200,000	100mΩ max.	3.0×2.7×1.4	—	—	●	
SKSGPJE010		Top push	2.0	0.12	200,000	100mΩ max.	3.0×2.7×1.4	—	—	●	
SKSGPGE010		Top push	2.8	0.12	200,000	100mΩ max.	3.0×2.7×1.4	—	—	●	
SKSGPAE010		Top push	4.0	0.12	200,000	100mΩ max.	3.0×2.7×1.4	—	—	●	

Note

1. This catalog shows only outline specifications. When using the products, please obtain formal specifications for supply.
2. Please place purchase orders for taping products per minimum order unit (1 reel or a case).

Packing Specifications

Taping

Number of packages (pcs.)			Tape width (mm)	Export package measurements (mm)
1 reel	1 case / Japan	1 case / export packing		
12,000	120,000	120,000	12	395 x 395 x 205

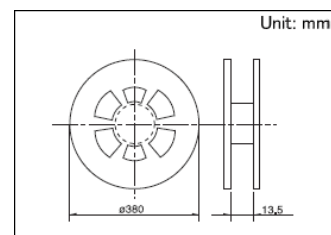

TACT Switch™ Surface Mount Type

3.0x2.7mm (Surface Mount)

SKSG Series

Drawing No.1

■ Dimensions

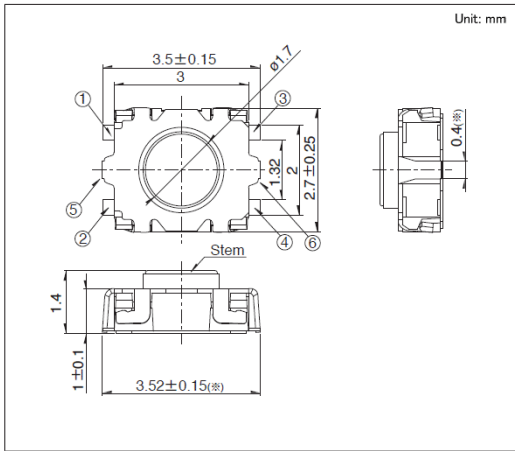

Parts indicated by ⑤, ⑥ and ※ apply only to products with a ground terminal.

■ Land Dimensions

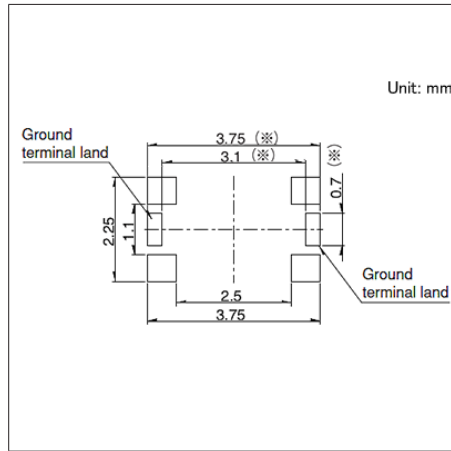

Viewed from switch mounting face
Parts indicated by a ※ apply only to products with a ground terminal.

■ Circuit Diagram

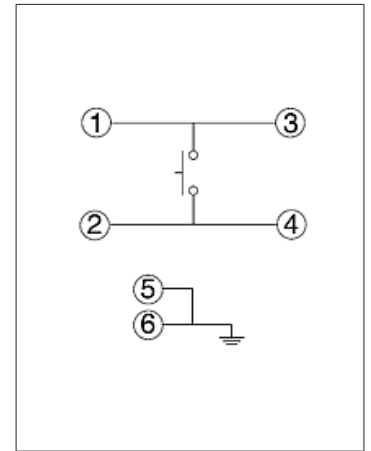

Parts indicated by ⑤ and ⑥ apply only to products with a ground terminal.

TACT Switch™ Surface Mount Type

3.9×2.9mm (Surface Mount)

SKRK Series

Short-stroke type with 0.13mm travel and heights of 1.5mm & 2.0mm.

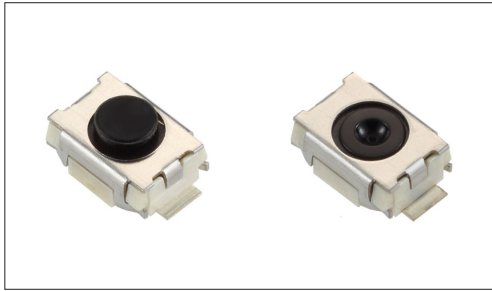

- Series type: Sharp feeling type
- Absolute Maximum Ratings: 50mA 12V DC
- Rating (min.): 10μA 1V DC

Applications: Mobile: Notebooks, peripherals
 Energy_Industrial: Robots, drones, Industrial equipment, Converters

Product List

Products No.	Operating direction	Operating force (N)	Travel (mm)	Operating life (cycles)	Initial contact resistance	Dimensions (W×D×H) (mm)	Water-proof	Dust-proof	Automotive	Drawing No.
SKRKAHE020	Top push	0.98	0.13	200,000	500mΩ max.	3.9×2.9×2.0	—	—	—	1
SKRKAEE020	Top push	1.57	0.13	200,000	100mΩ max.	3.9×2.9×2.0	—	—	—	
SKRKAGE020	Top push	1.57	0.13	200,000	100mΩ max.	3.9×2.9×1.5	—	—	—	2

⚠ Note

1. This catalog shows only outline specifications. When using the products, please obtain formal specifications for supply.
2. Please place purchase orders for taping products per minimum order unit (1 reel or a case).

Packing Specifications

Taping

Products No.	Number of packages (pcs.)			Tape width (mm)	Export package measurements (mm)
	1 reel	1 case / Japan	1 case / export packing		
SKRKAHE020 SKRKAEE020	4,500	45,000	45,000	12	395 x 395 x 205
SKRKAGE020	5,000	50,000	50,000	12	395 x 395 x 205

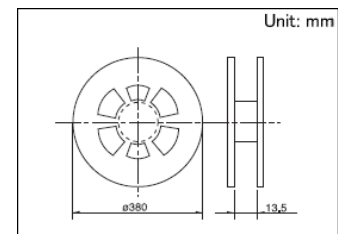

Drawing No. 1

Dimensions

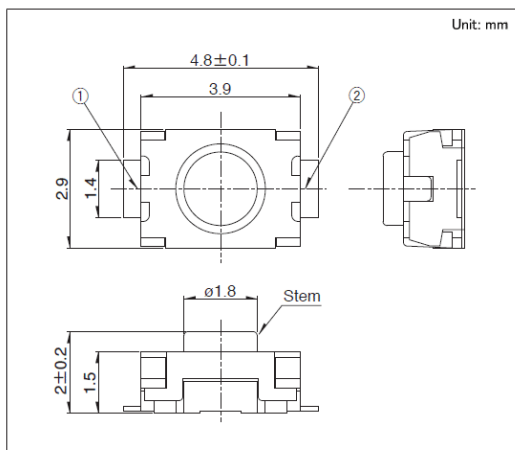

Land Dimensions

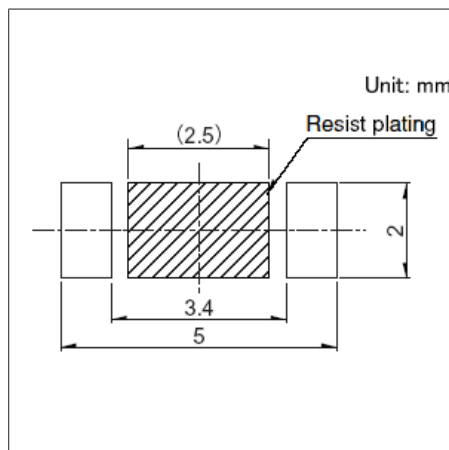

Circuit Diagram

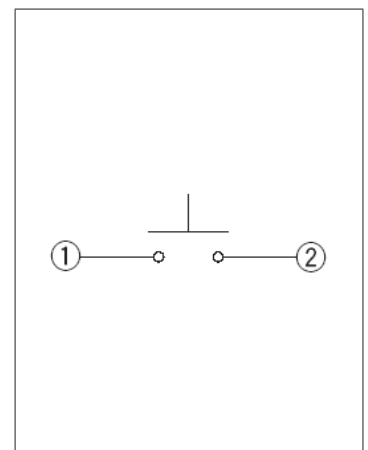

Viewed from mounting face.

Drawing No.2

■ Dimensions

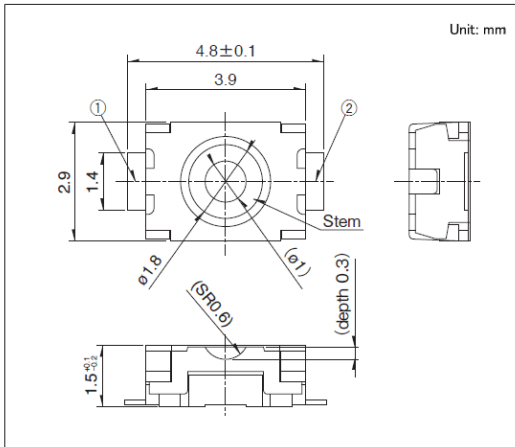

■ Land Dimensions

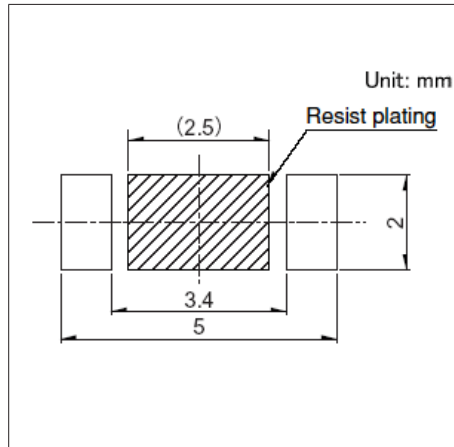

■ Circuit Diagram

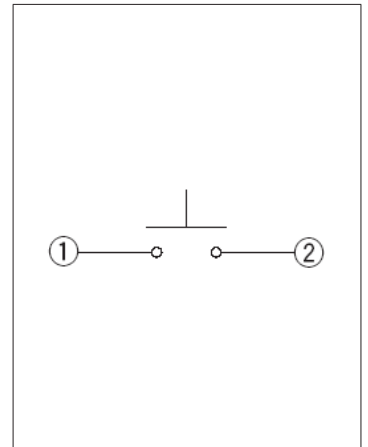

Viewed from mounting face.

TACT Switch™ Surface Mount Type

3.5×3.2mm (Surface Mount)

SKTH Series

Short-stroke type with dust-proof performance (IP6X equivalent) due to contact sealing structure, automotive-compatible.

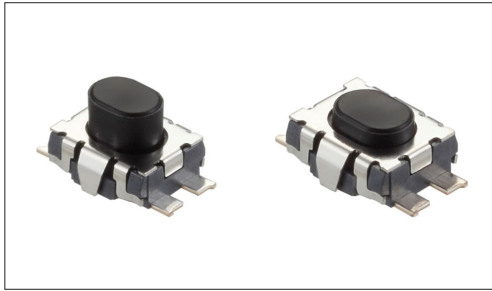

Automotive

Dust-proof Type

- Series type: Sharp feeling type
- Absolute Maximum Ratings: 25mA 16V DC
- Rating (min.): 10μA 1V DC

Applications: Energy_Industrial: Robots, drones, Industrial equipment, Converters
 Game: Home handheld consoles
 Automotive: Remote Keyless Entry (RKE), Navigation/audio systems, HVAC, Overhead consoles, Steering

Product List

Products No.	Operating direction	Operating force (N)	Travel (mm)	Operating life (cycles)	Initial contact resistance	Dimensions (W×D×H) (mm)	Water-proof	Dust-proof	Water-proof & Dust-proof	Automotive	Drawing No.
SKTHBAE010	Top push	3.0	0.12	200,000	500mΩ max.	3.5×3.2×2.5	—	●	IP6X equivalent	●	1
SKTHACE010	Top push	1.4	0.12	100,000	1Ω max.	3.5×3.2×1.8	—	●	IP6X equivalent	●	2
SKTHAEE010	Top push	5.0	0.15	200,000	500mΩ max.	3.5×3.2×1.75	—	●	IP6X equivalent	●	3
SKTHAHE010	Top push	3.0	0.12	200,000	500mΩ max.	3.5×3.2×1.8	—	●	IP6X equivalent	●	2
SKTHAJE010	Top push	7.0	0.15	100,000	500mΩ max.	3.5×3.2×1.75	—	●	IP6X equivalent	●	3

Note

1. This catalog shows only outline specifications. When using the products, please obtain formal specifications for supply.
2. Please place purchase orders for taping products per minimum order unit (1 reel or a case).

Packing Specifications

Taping

Products No.	Number of packages(pcs.)			Tape width (mm)	Export package measurements (mm)
	1 reel	1 case / Japan	1 case / export packing		
SKTHBAE010	4,000	40,000	40,000	12	395 x 395 x 205
SKTHACE010 SKTHAEE010 SKTHAHE010 SKTHAJE010	5,000	50,000	50,000	12	395 x 395 x 205

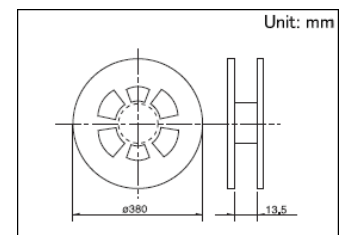

TACT Switch™ Surface Mount Type

3.5x3.2mm (Surface Mount)

SKTH Series

Drawing No.1

■ Dimensions

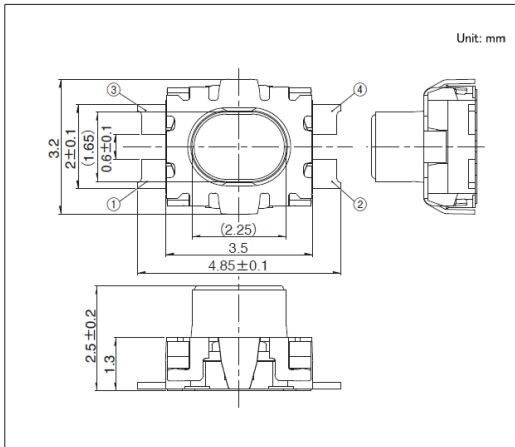

■ Land Dimensions

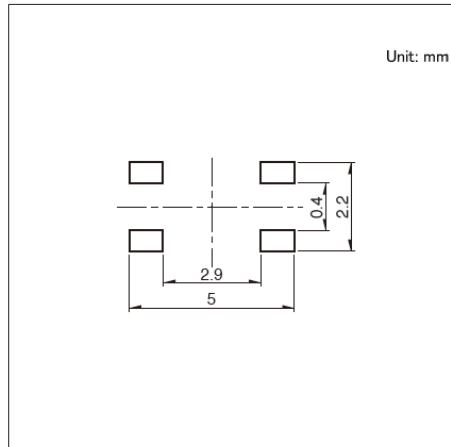

■ Circuit Diagram

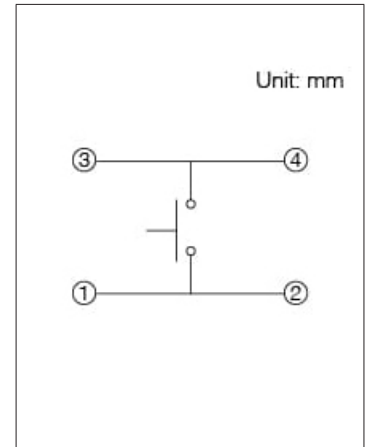

Viewed from mounting face.

Drawing No.2

■ Dimensions

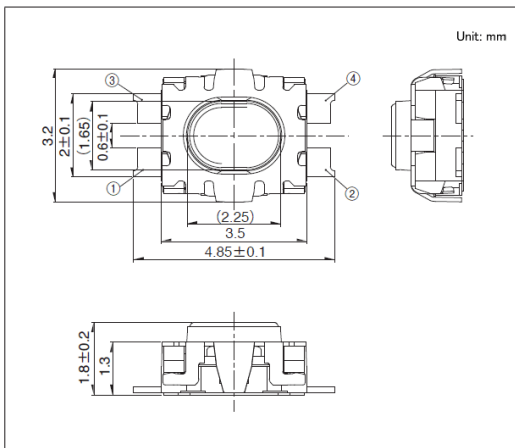

■ Land Dimensions

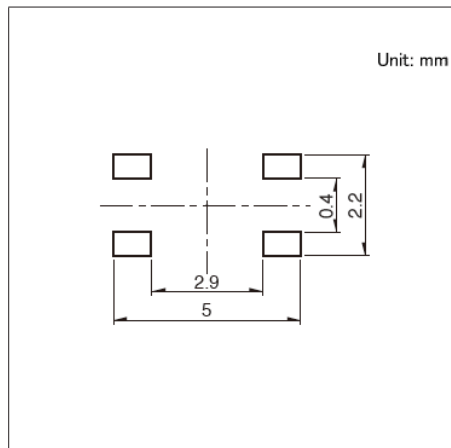

■ Circuit Diagram

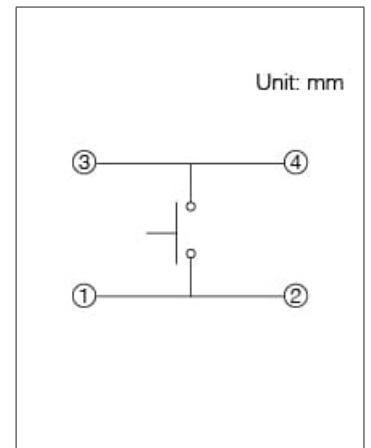

Viewed from switch mounting face

Drawing No.3

■ Dimensions

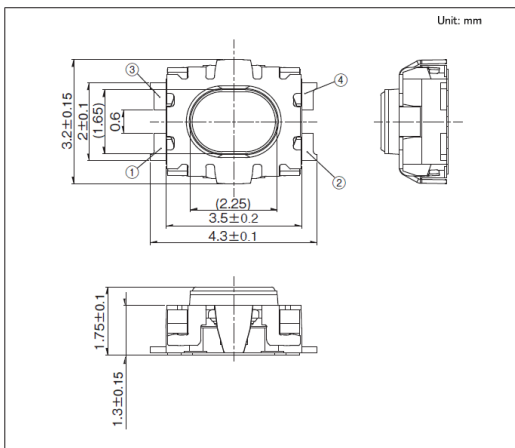

■ Land Dimensions

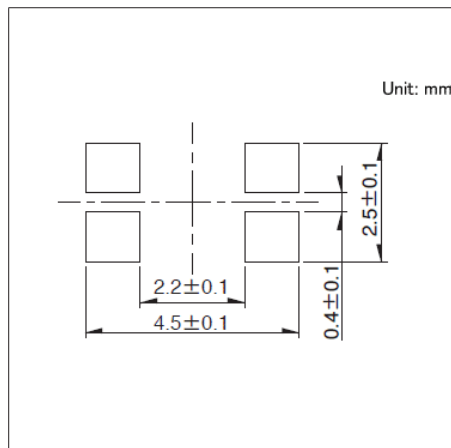

■ Circuit Diagram

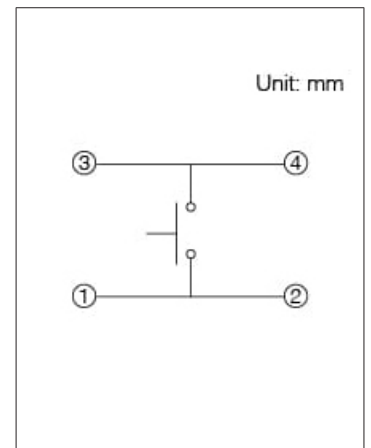

Viewed from switch mounting face

TACT Switch™ Surface Mount Type

4.2×3.2mm Compact High Operating Force (Surface Mount)

SKRP Series

Short-stroke type with a height of 2.5mm, 0.2mm travel, wide stem area for excellent mountability, with long-life options.

 Automotive

※Please check the product list for compatible products

- Series type: Sharp feeling type
- Absolute Maximum Ratings: 50mA 16V DC
- Rating (min.): 10μA 1V DC

Applications: Mobile: Notebooks, peripherals
 Energy_Industrial: Robots, drones, Industrial equipment, Converters
 Game: Home handheld consoles, Virtual/augmented reality
 Healthcare: Healthcare equipment, Nursing care equipment, Analysis, test equipment
 Home: Major home appliances, Office equipment
 Audio_TV: Visual, Audio, Pro audio
 Automotive: Remote Keyless Entry (RKE), Navigation/audio systems, HVAC, Overhead consoles, Steering, Shifter

Product List

Products No.	Type	Operating direction	Operating force (N)	Travel (mm)	Operating life (cycles)	Initial contact resistance	Dimensions (W×D×H) (mm)	Water-proof	Dust-proof	Automotive	Drawing No.
SKRPAKE010	Standard type	Top push	1.0	0.15	1,000,000	500mΩ max.	4.2×3.2×2.5	—	—	—	1
SKRPABE010		Top push	1.57	0.2	100,000	500mΩ max.	4.2×3.2×2.5	—	—	●	
SKRPACE010		Top push	2.55	0.2	50,000	500mΩ max.	4.2×3.2×2.5	—	—	●	
SKRPAME010		Top push	3.0	0.2	100,000	500mΩ max.	4.2×3.2×2.5	—	—	●	
SKRPADE010		Top push	4.0	0.2	100,000	500mΩ max.	4.2×3.2×2.5	—	—	●	
SKRPARE010		Top push	5.0	0.2	300,000	500mΩ max.	4.2×3.2×2.5	—	—	●	
SKRPANE010	Long life type	Top push	1.57	0.2	1,000,000	500mΩ max.	4.2×3.2×2.5	—	—	●	
SKRPASE010		Top push	2.55	0.2	500,000	500mΩ max.	4.2×3.2×2.5	—	—	●	

Note

1. This catalog shows only outline specifications. When using the products, please obtain formal specifications for supply.
2. Please place purchase orders for taping products per minimum order unit (1 reel or a case).

Packing Specifications

Taping

Number of packages (pcs.)			Tape width (mm)	Export package measurements (mm)
1 reel	1 case / Japan	1 case / export packing		
4,000	40,000	40,000	12	395 x 395 x 205

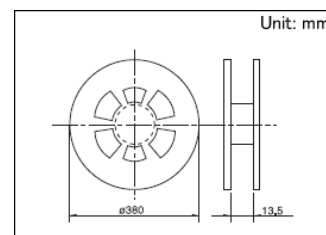

Drawing No.1

■ Dimensions

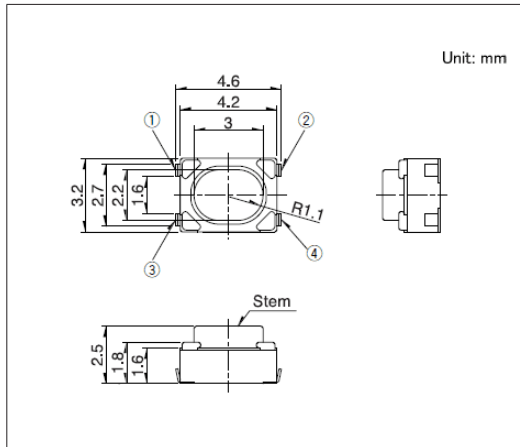

■ Land Dimensions

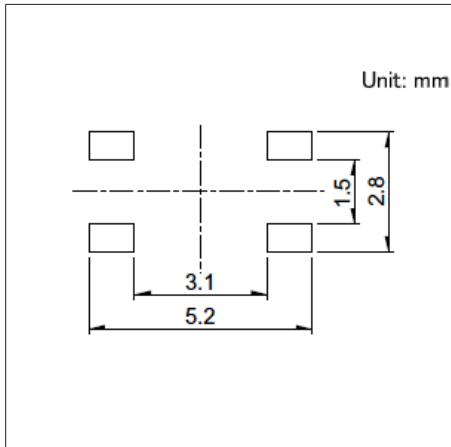

■ Circuit Diagram

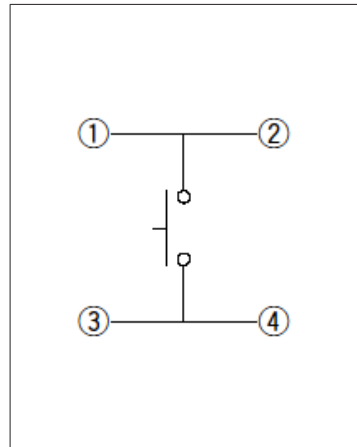

Viewed from mounting face.

TACT Switch™ Surface Mount Type

6.0×3.5mm (Surface Mount)

SKQM Series

Heights of 4.3mm and 5mm available.

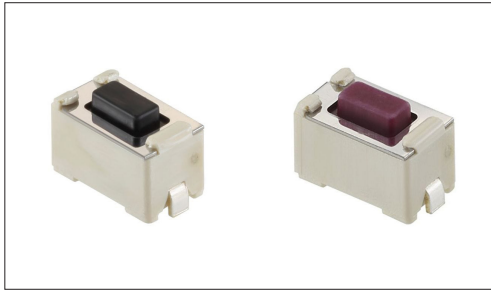

 Automotive

- Series type: Sharp feeling type
- Absolute Maximum Ratings: 50mA 12V DC
- Rating (min.): 10μA 1V DC

Applications: Energy_Industrial: Industrial equipment
 Home: Office equipment
 Automotive: Navigation/audio systems, HVAC,
 Overhead consoles, Steering

Product List

Products No.	Operating direction	Operating force (N)	Travel (mm)	Operating life (cycles)	Initial contact resistance	Dimensions (W×D×H) (mm)	Water-proof	Dust-proof	Automotive	Drawing No.
SKQMBAE010	Top push	0.98	0.25	50,000	500mΩ max.	6.0×3.5×4.3	—	—	●	1
SKQMASE010	Top push	1.57	0.25	50,000	500mΩ max.	6.0×3.5×4.3	—	—	●	
SKQMAQE010	Top push	2.55	0.25	30,000	500mΩ max.	6.0×3.5×4.3	—	—	●	
SKQMATE010	Top push	0.98	0.25	50,000	500mΩ max.	6.0×3.5×5.0	—	—	●	2
SKQMBBE010	Top push	1.57	0.25	50,000	500mΩ max.	6.0×3.5×5.0	—	—	●	
SKQMARE010	Top push	2.55	0.25	30,000	500mΩ max.	6.0×3.5×5.0	—	—	●	

Note

1. This catalog shows only outline specifications. When using the products, please obtain formal specifications for supply.
2. Please place purchase orders for taping products per minimum order unit (1 reel or a case).

Packing Specifications

Taping

Number of packages (pcs.)			Tape width (mm)	Export package measurements (mm)
1 reel	1 case / Japan	1 case / export packing		
2,000	20,000	20,000	12	395 x 395 x 205

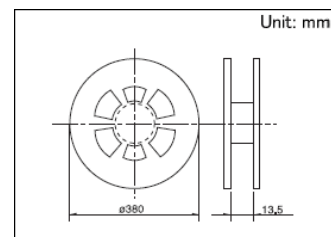

TACT Switch™ Surface Mount Type

6.0×3.5mm (Surface Mount)

SKQM Series

Drawing No.1

■ Dimensions

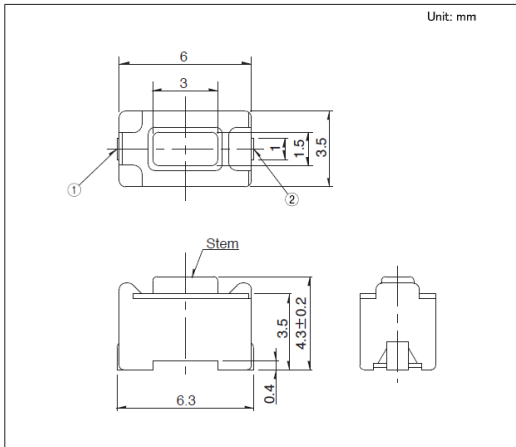

■ Land Dimensions

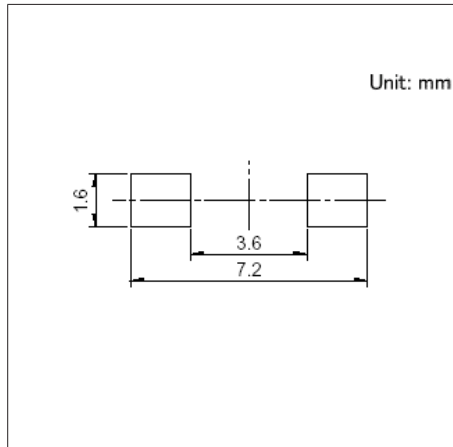

■ Circuit Diagram

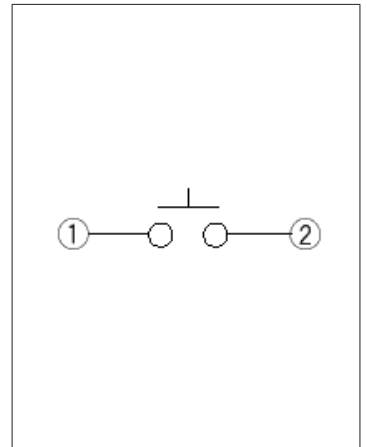

Viewed from mounting face.

Drawing No.2

■ Dimensions

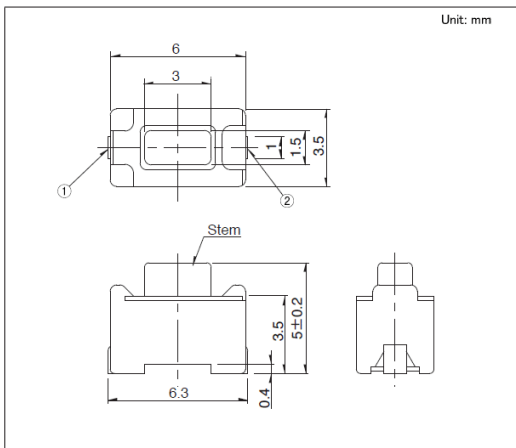

■ Land Dimensions

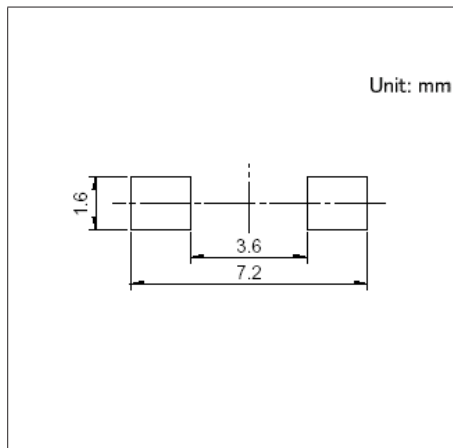

■ Circuit Diagram

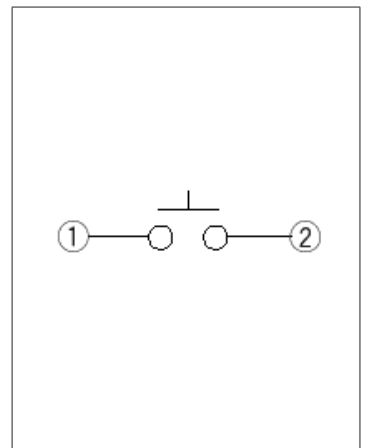

Viewed from mounting face.

TACT Switch™ Surface Mount Type

6.1×3.7mm (Surface Mount)

SKQY Series

High-speed mounting type with a height of 2.5mm, with ground terminal options.

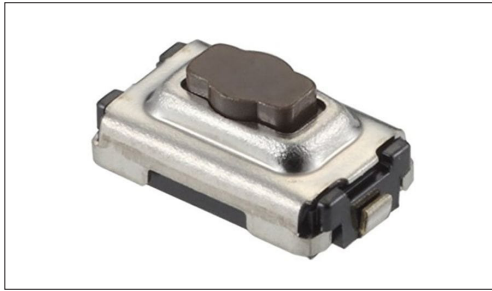

 Automotive

- Series type: Sharp feeling type
- Absolute Maximum Ratings: 50mA 12V DC
- Rating (min.): 10μA 1V DC

Applications: Energy_Industrial: Industrial equipment
Home: Office equipment
Automotive: Navigation/audio systems, HVAC,
Overhead consoles, Steering

Product List

Products No.	Type	Operating direction	Operating force (N)	Travel (mm)	Operating life (cycles)	Initial contact resistance	Dimensions (W×D×H) (mm)	Water-proof	Dust-proof	Automotive	Drawing No.
SKQYACE010	Top push type	Top push	0.98	0.25	50,000	500mΩ max.	6.1×3.7×2.5	—	—	●	1
SKQYAAE010		Top push	1.57	0.25	50,000	500mΩ max.	6.1×3.7×2.5	—	—	●	
SKQYABE010		Top push	2.55	0.25	50,000	500mΩ max.	6.1×3.7×2.5	—	—	●	
SKQYAFE010		Top push	3.14	0.25	50,000	500mΩ max.	6.1×3.7×2.5	—	—	●	
SKQYPCE010	With ground terminal type	Top push	0.98	0.25	50,000	500mΩ max.	6.1×3.7×2.5	—	—	●	2
SKQYPAE010		Top push	1.57	0.25	50,000	500mΩ max.	6.1×3.7×2.5	—	—	●	
SKQYPBE010		Top push	2.55	0.25	50,000	500mΩ max.	6.1×3.7×2.5	—	—	●	
SKQYPDE010		Top push	3.14	0.25	50,000	500mΩ max.	6.1×3.7×2.5	—	—	●	

Note

1. This catalog shows only outline specifications. When using the products, please obtain formal specifications for supply.
2. Please place purchase orders for taping products per minimum order unit (1 reel or a case).

Packing Specifications

Taping

Number of packages (pcs.)			Tape width (mm)	Export package measurements (mm)
1 reel	1 case / Japan	1 case / export packing		
3,000	30,000	30,000	12	395 x 395 x 205

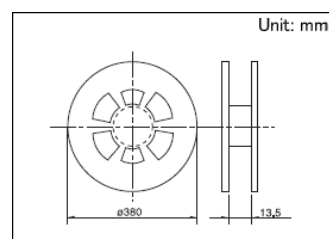

Drawing No.1

■ Dimensions

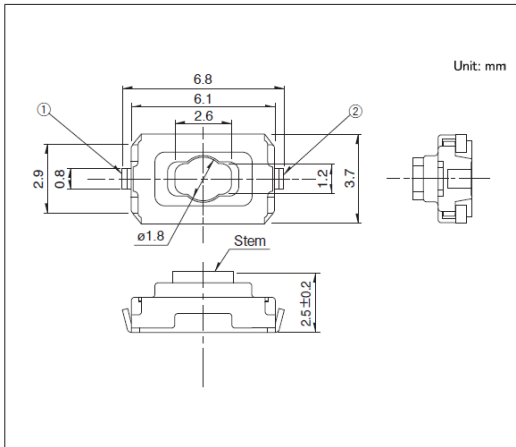

■ Land Dimensions

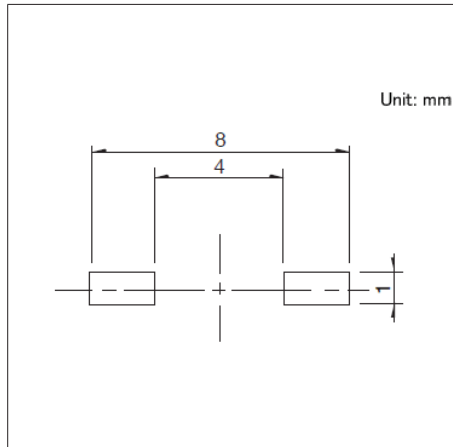

■ Circuit Diagram

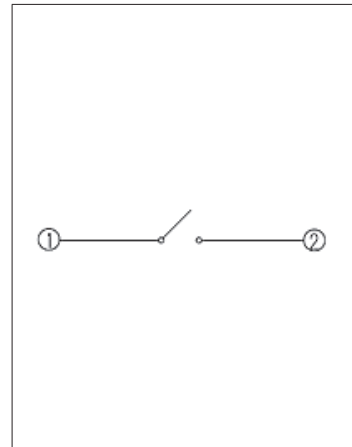

Viewed from mounting face.

Drawing No.2

■ Dimensions

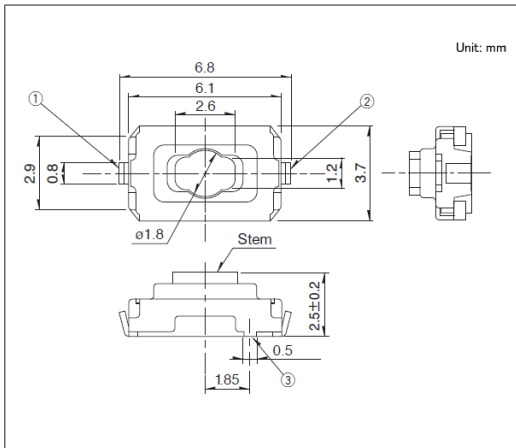

■ Land Dimensions

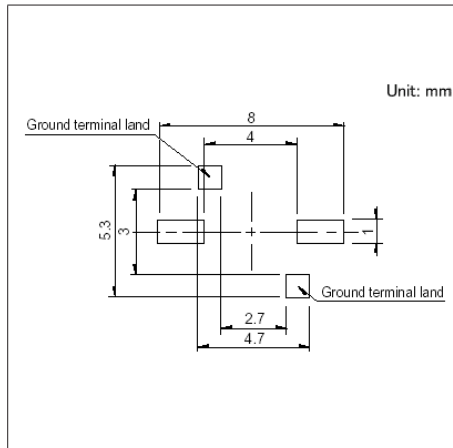

■ Circuit Diagram

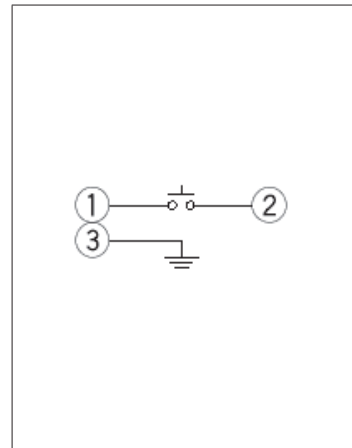

Viewed from mounting face.

TACT Switch™ Surface Mount Type

5.3×5.4mm (Surface Mount)

SKTQ Series

Compact mid-stroke type with reliable operation feel, including small-click and long-life variants.

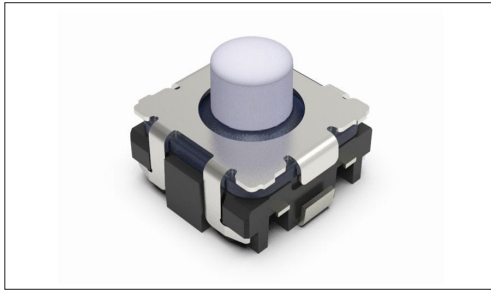

 Automotive

- Series type: Sharp feeling type
- Absolute Maximum Ratings: 50mA 16V DC
- Rating (min.): 10μA 1V DC

Applications: Automotive: Navigation/audio systems, HVAC, Overhead consoles, Steering, Shifter

Product List

Products No.	Operating direction	Operating force (N)	Click type	Travel (mm)	Operating life (cycles)	Initial contact resistance	Dimensions (W×D×H) (mm)	Water-proof	Dust-proof	Automotive	Drawing No.
SKTQADE010	Top push	2.5	Standard	0.7	200,000	100mΩ max.	5.3×5.4×4.25	—	—	●	1
SKTQABE010	Top push	3.0	Standard	0.71	200,000	100mΩ max.	5.3×5.4×4.25	—	—	●	
SKTQAAE010	Top push	5.0	Standard	0.71	200,000	100mΩ max.	5.3×5.4×4.25	—	—	●	
SKTQAGE010	Top push	5.0	Standard	0.7	1,000,000	100mΩ max.	5.3×5.4×4.25	—	—	●	
SKTQAFE010	Top push	3.0	Low click	0.73	500,000	100mΩ max.	5.3×5.4×4.25	—	—	●	
SKTQACE010	Top push	3.5	Low click	0.71	500,000	100mΩ max.	5.3×5.4×4.25	—	—	●	
SKTQAAE010	Top push	5.0	Low click	0.74	200,000	100mΩ max.	5.3×5.4×4.25	—	—	●	

Note

1. This catalog shows only outline specifications. When using the products, please obtain formal specifications for supply.
2. Please place purchase orders for taping products per minimum order unit (1 reel or a case).

Packing Specifications

Taping

Number of packages (pcs.)			Tape width (mm)	Export package measurements (mm)
1 reel	1 case / Japan	1 case / export packing		
2,200	17,600	17,600	16	395 x 395 x 205

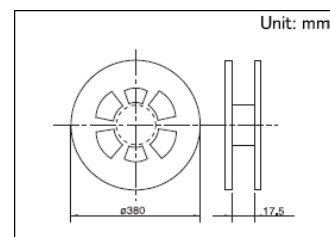

TACT Switch™ Surface Mount Type

5.3×5.4mm (Surface Mount)

SKTQ Series

Drawing No.1

■ Dimensions

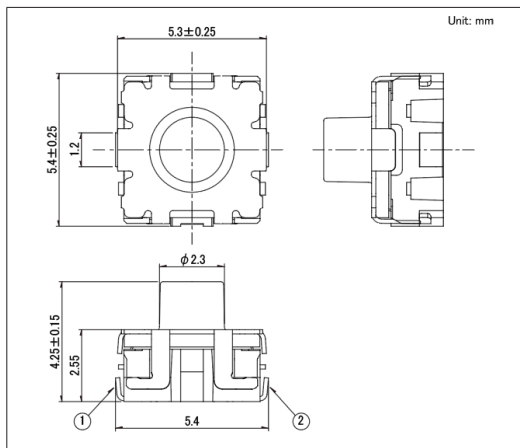

■ Land Dimensions

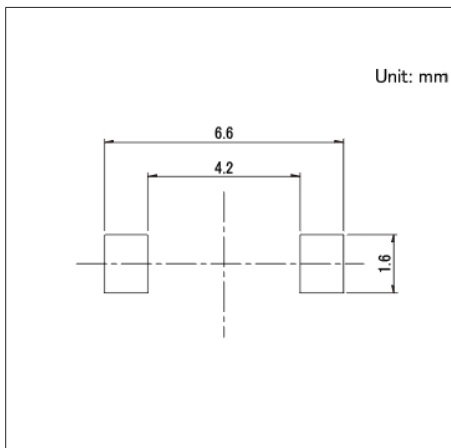

■ Circuit Diagram

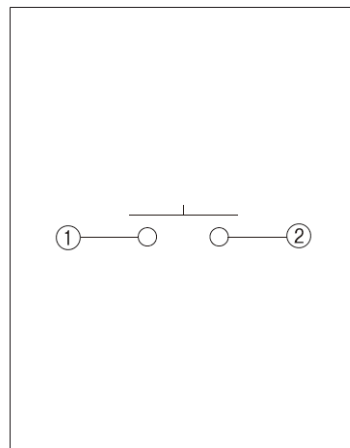

Viewed from switch mounting face

TACT Switch™ Surface Mount Type

5.3×5.4mm (Surface Mount)

SKSU Series

Compact, quiet, heavy-duty mid-stroke type compliant with IP6X equivalent/IPX7.



Automotive

Water-proof Type

Dust-proof Type

※Please check the product list for compatible products

- Series type: Sharp feeling type
- Absolute Maximum Ratings: 50mA 16V DC
- Rating (min.): 10μA 1V DC

Applications: Home: Major home appliances
 Mobile: Headsets, wearables
 Game: Home handheld consoles
 Audio_TV: Pro audio
 Automotive: Navigation/audio systems, HVAC,
 Overhead consoles, Steering, Shifter

Product List

Products No.	Operating direction	Operating force (N)	Travel (mm)	Operating life (cycles)	Initial contact resistance	Dimensions (W×D×H) (mm)	Water-proof	Dust-proof	Water-proof & Dust-proof	Automotive	Drawing No.
SKSUBCE010	Top push	3.0	0.9	250,000	100mΩ max.	5.3×5.4×4.34	●	●	IP6X equivalent/IPX7	●	1
SKSUAAE010	Top push	3.5	0.7	250,000	100mΩ max.	5.3×5.4×3.85	●	●	IP6X equivalent/IPX7	●	2
SKSUBBE010	Top push	5.0	1.04	250,000	100mΩ max.	5.3×5.4×4.34	●	●	IP6X equivalent/IPX7	●	1
SKSUBDE010	Top push	1.4	0.8	2,000,000	500mΩ max.	5.3×5.4×4.34	●	●	IP6X equivalent/IPX7	—	

⚠Note

1. This catalog shows only outline specifications. When using the products, please obtain formal specifications for supply.
2. Please place purchase orders for taping products per minimum order unit (1 reel or a case).
3. Protective structure :
 Assumes the switch is left alone without being operated. Under the specified conditions, dust and water ingress with a significant impact on the switch's on-off function is prevented.
 IP6X equivalent/IPX7 dust and water resistance is guaranteed for the switch alone and performance may not be guaranteed depending on the mounting conditions and usage.

Packing Specifications

Taping

Products No.	Number of packages(pcs.)			Tape width (mm)	Export package measurements (mm)
	1 reel	1 case / Japan	1 case / export packing		
SKSUBCE010 SKSUBBE010 SKSUBDE010	2,200	17,600	17,600	16	395 x 395 x 205
SKSUAAE010	2,400	19,200	19,200	16	395 x 395 x 205

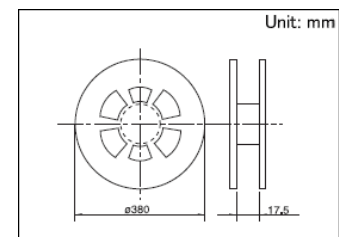

TACT Switch™ Surface Mount Type

5.3x5.4mm (Surface Mount)

SKSU Series

Drawing No.1

■ Dimensions

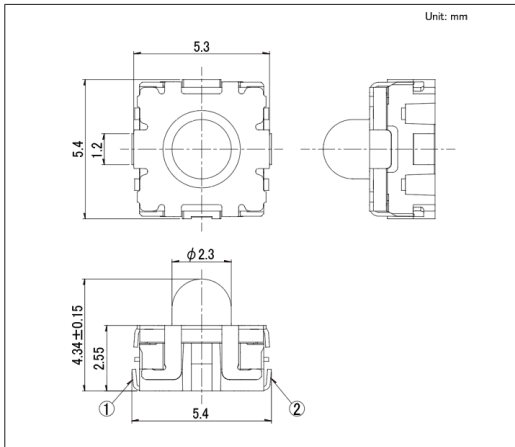

■ Land Dimensions

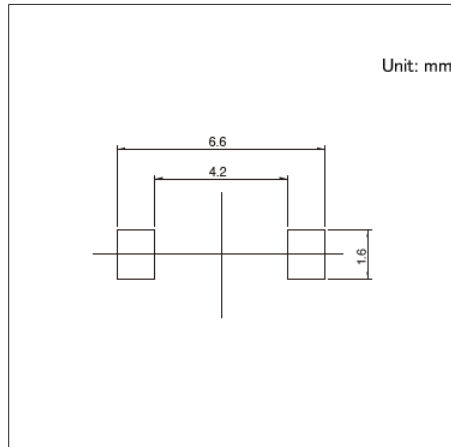

■ Circuit Diagram

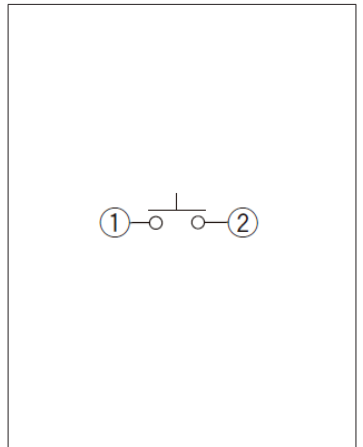

Viewed from switch mounting face

Drawing No.2

■ Dimensions

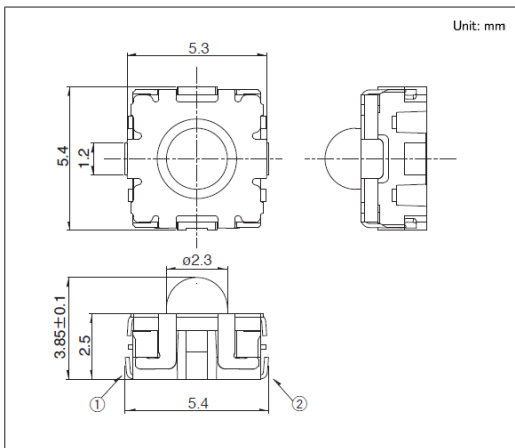

■ Land Dimensions

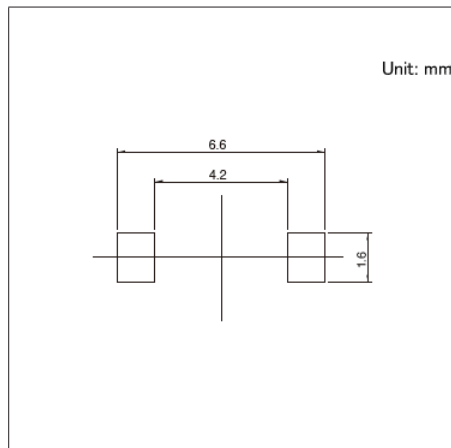

■ Circuit Diagram

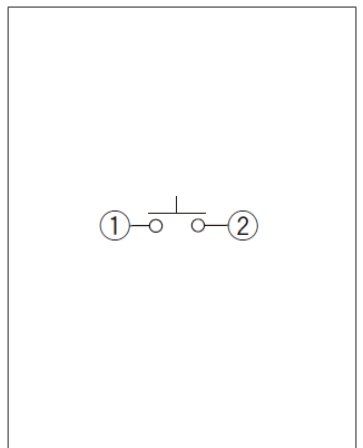

Viewed from switch mounting face

TACT Switch™ Surface Mount Type

6.1mm Square (Surface Mount) SKTR Series

Quiet mid-stroke type with reliable operation feel and dust-proof performance (IP6X equivalent).

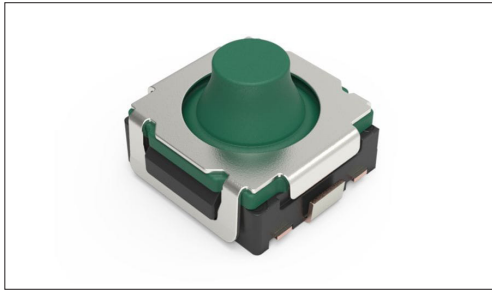

Automotive

Dust-proof Type

- Series type: Sharp feeling type
- Absolute Maximum Ratings: 50mA 16V DC
- Rating (min.): 10μA 1V DC

Applications: Automotive: Navigation/audio systems, HVAC, Overhead consoles, Steering, Shifter

Product List

Products No.	Operating direction	Operating force (N)	Click type	Travel (mm)	Operating life (cycles)	Initial contact resistance	Dimensions (W×D×H) (mm)	Water-proof	Dust-proof	Water-proof & Dust-proof	Automotive	Drawing No.
SKTRAE010	Top push	3.8	Standard	0.72	200,000	500mΩ max.	6.1×6.1×4.1	—	●	IP6X equivalent	●	1
SKTRAF010	Top push	4.0	Low click	0.78	200,000	500mΩ max.	6.1×6.1×4.1	—	●	IP6X equivalent	●	
SKTRAGE010	Top push	3.0	Low click	0.75	200,000	500mΩ max.	6.1×6.1×4.1	—	●	IP6X equivalent	●	

Note

1. This catalog shows only outline specifications. When using the products, please obtain formal specifications for supply.
2. Please place purchase orders for taping products per minimum order unit (1 reel or a case).

Packing Specifications

Taping

Number of packages (pcs.)			Tape width (mm)	Export package measurements (mm)
1 reel	1 case / Japan	1 case / export packing		
2,500	25,000	25,000	12	395 x 395 x 205

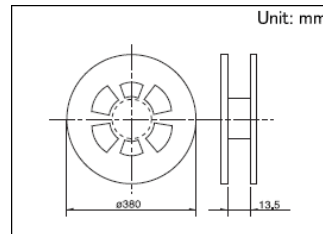

Drawing No. 1

Dimensions

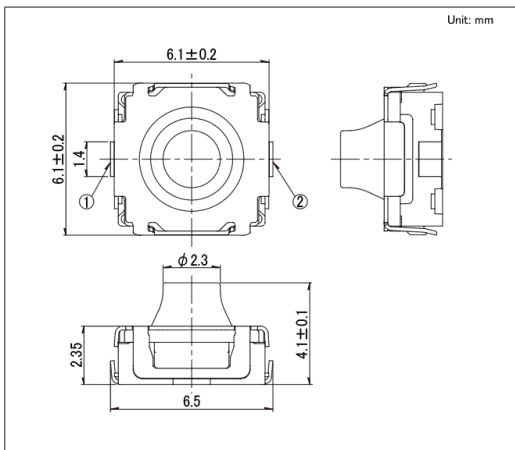

Land Dimensions

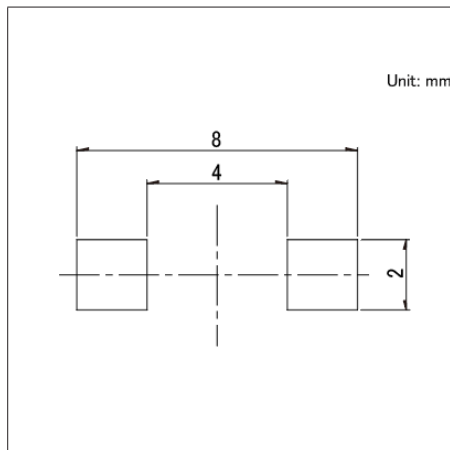

Circuit Diagram

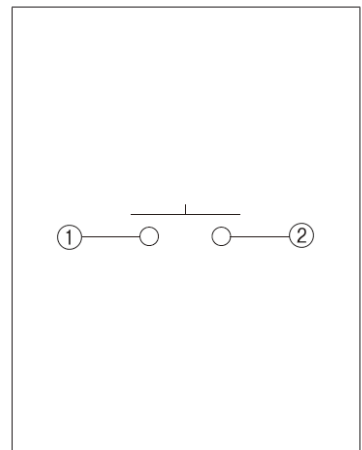

Viewed from switch mounting face

TACT Switch™ Surface Mount Type

6.2mm Square (Surface Mount) SKTT Series

Mid-stroke type with a height of 4.4mm, operating force of 4N, 500,000 operation cycles, and 0.36mm travel.

 Automotive

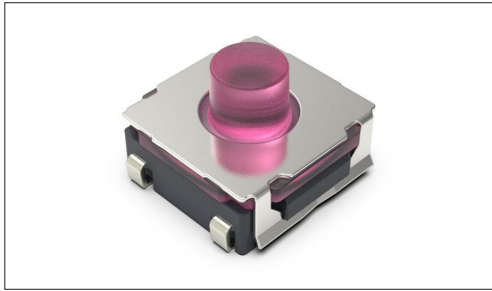

- Series type: Sharp feeling type
- Absolute Maximum Ratings: 50mA 16V DC
- Rating (min.): 10μA 1V DC

Applications: Energy_Industrial: Industrial equipment
 Healthcare: Healthcare equipment
 Home: Major home appliances
 Automotive: Navigation/audio systems, HVAC, Steering

Product List

Products No.	Operating direction	Operating force (N)	Travel (mm)	Operating life (cycles)	Initial contact resistance	Dimensions (W×D×H) (mm)	Water-proof	Dust-proof	Automotive	Drawing No.
SKTTABE010	Top push	4.0	0.36	500,000	100mΩ max.	6.2×6.2×4.4	—	—	●	1

Note

1. This catalog shows only outline specifications. When using the products, please obtain formal specifications for supply.
2. Please place purchase orders for taping products per minimum order unit (1 reel or a case).

Packing Specifications

Taping

Number of packages (pcs.)			Tape width (mm)	Export package measurements (mm)
1 reel	1 case / Japan	1 case / export packing		
1,600	12,800	12,800	16	395 x 395 x 205

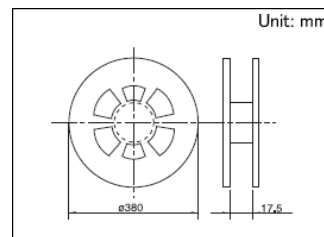

Drawing No.1

Dimensions

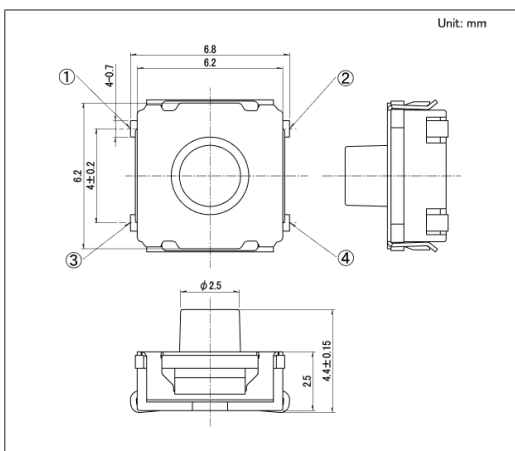

Land Dimensions

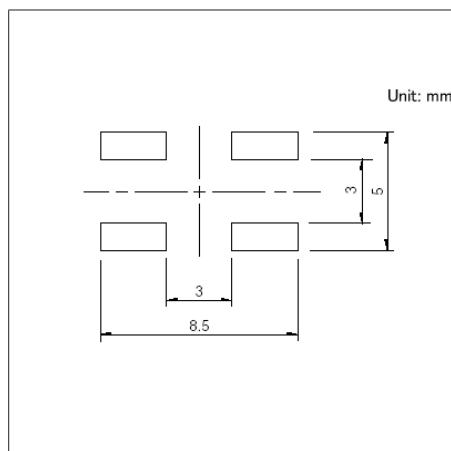

Circuit Diagram

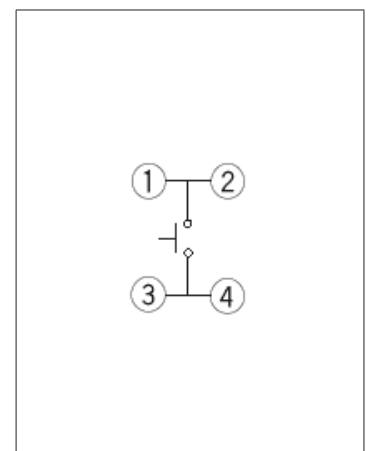

Viewed from switch mounting face

TACT Switch™ Surface Mount Type

6.2mm Square (Surface Mount) SKRA Series

Variety of mid-stroke types with rubber stems and 0.25–0.55mm travel.

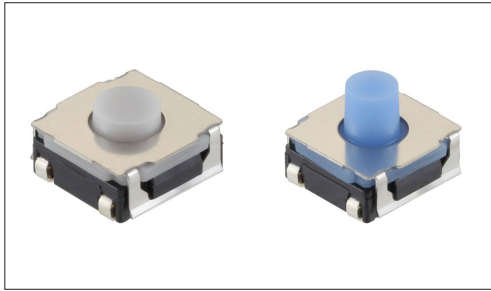

Automotive

Water-proof Type

Dust-proof Type

※Please check the product list for compatible products

- Series type: Sharp feeling type
- Absolute Maximum Ratings: 50mA 12V DC
- Rating (min.): 10μA 1V DC

Applications: Mobile: Notebooks, peripherals
 Energy_Industrial: Robots, drones, Industrial equipment, Converters
 Game: Home handheld consoles, Virtual/augmented reality
 Healthcare: Healthcare equipment, Nursing care equipment, Analysis, test equipment
 Home: Major home appliances, Office equipment
 Automotive: Navigation/audio systems, HVAC, Overhead consoles, Steering, Shifter

Product List

Products No.	Operating direction	Operating force (N)	Travel (mm)	Operating life (cycles)	Initial contact resistance	Dimensions (W×D×H) (mm)	Water-proof	Dust-proof	Water-proof & Dust-proof	Automotive	Drawing No.
SKRAAWE010	Top push	0.6	0.3	4,000,000	100mΩ max	6.2×6.2×3.5	—	—	—	—	1
SKRAAKE010	Top push	2.45	0.3	100,000	100mΩ max	6.2×6.2×3.5	●	●	IP6X equivalent/IPX7	●	2
SKRAALE010	Top push	3.92	0.35	100,000	100mΩ max.	6.2×6.2×3.5	●	●	IP6X equivalent/IPX7	●	
SKRAAME010	Top push	1.96	0.5	100,000	100mΩ max.	6.2×6.2×5.2	●	●	IP6X equivalent/IPX7	●	3
SKRAAQE010	Top push	3.43	0.55	100,000	100mΩ max.	6.2×6.2×5.2	●	●	IP6X equivalent/IPX7	●	
SKRABCE010	Top push	1.2	0.4	3,000,000	100mΩ max.	6.2×6.2×3.5	—	—	—	—	1
SKRABGE010	Top push	2.0	0.25	2,000,000	100mΩ max.	6.2×6.2×3.5	●	●	IP6X equivalent/IPX7	—	2
SKRABNE010	Top push	2.0	0.4	5,000,000	100mΩ max.	6.2×6.2×3.4	●	●	IP6X equivalent/IPX7	—	4

⚠Note

1. This catalog shows only outline specifications. When using the products, please obtain formal specifications for supply.
2. Please place purchase orders for taping products per minimum order unit (1 reel or a case).
3. Protective structure :
 Assumes the switch is left alone without being operated. Under the specified conditions, dust and water ingress with a significant impact on the switch's on-off function is prevented.
 IP6X equivalent/IPX7 dust and water resistance is guaranteed for the switch alone and performance may not be guaranteed depending on the mounting conditions and usage.

Packing Specifications

Taping

Products No.	Number of packages (pcs.)			Reel width W (mm)	Tape width (mm)	Export package measurements (mm)
	1 reel	1 case / Japan	1 case / export packing			
SKRAAWE010 SKRAAKE010 SKRAALE010 SKRABCE010 SKRABGE010	3,000	30,000	30,000	13.5	12	395 x 395 x 205
SKRAAME010 SKRAAQE010	1,400	11,200	11,200	17.5	16	395 x 395 x 205
SKRABNE010	3,000	30,000	30,000	—	12	395×395×205

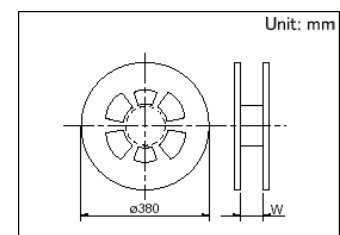

TACT Switch™ Surface Mount Type

6.2mm Square (Surface Mount)
SKRA Series

Drawing No.1

■ Dimensions

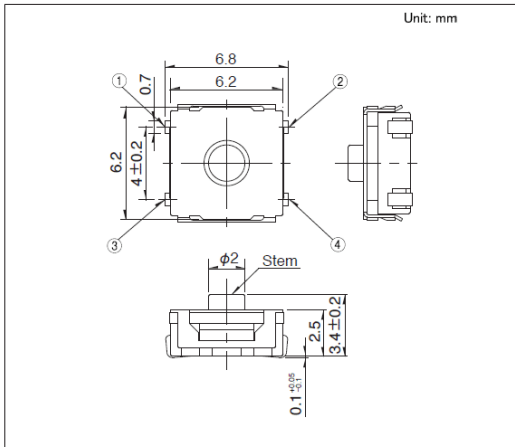

■ Land Dimensions

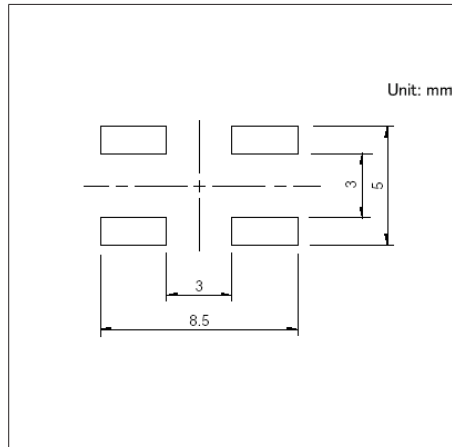

■ Circuit Diagram

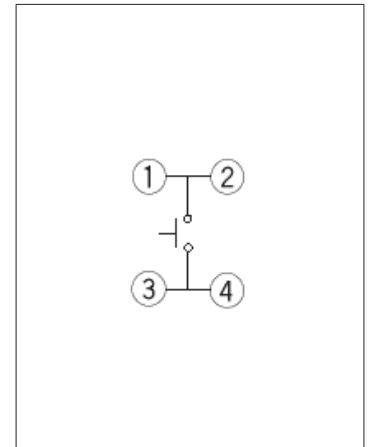

Viewed from switch mounting face

Drawing No.2

■ Dimensions

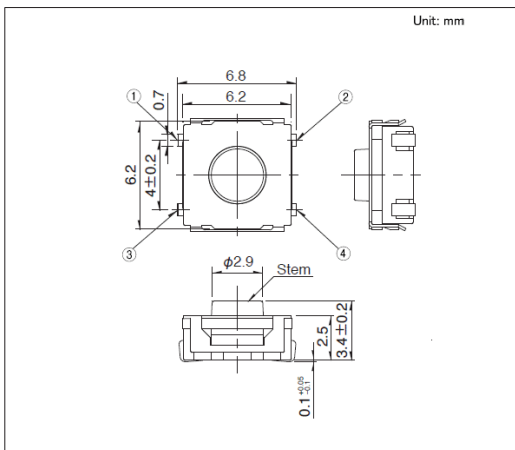

■ Land Dimensions

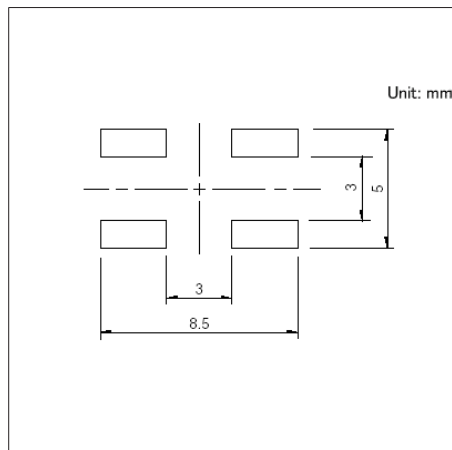

■ Circuit Diagram

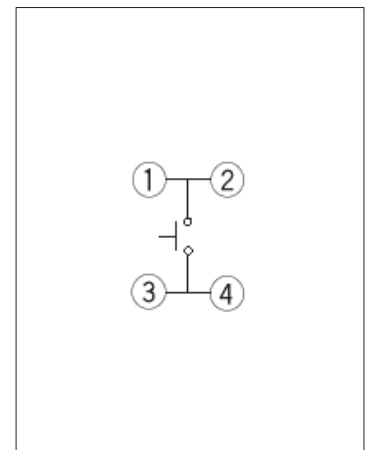

Viewed from switch mounting face

Drawing No.3

■ Dimensions

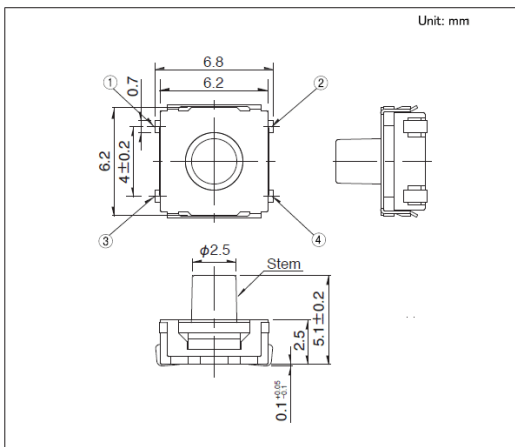

■ Land Dimensions

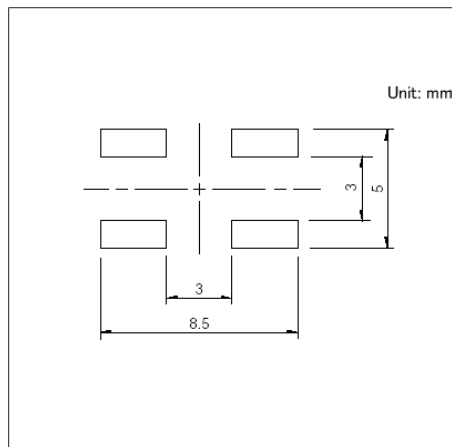

■ Circuit Diagram

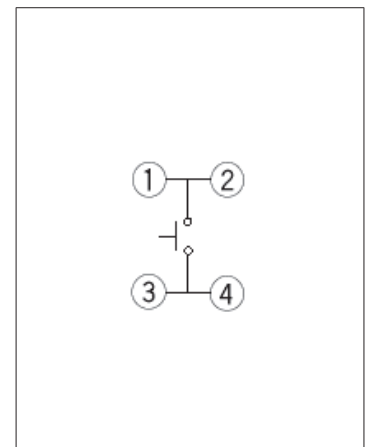

Viewed from switch mounting face

Drawing No.4

■ Dimensions

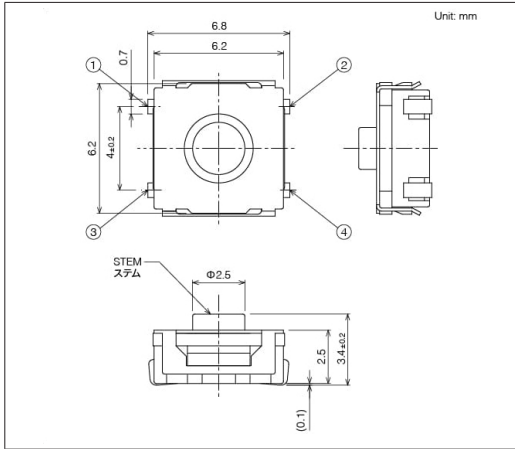

■ Land Dimensions

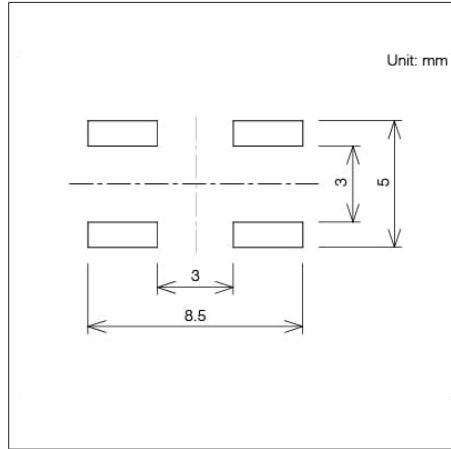

■ Circuit Diagram

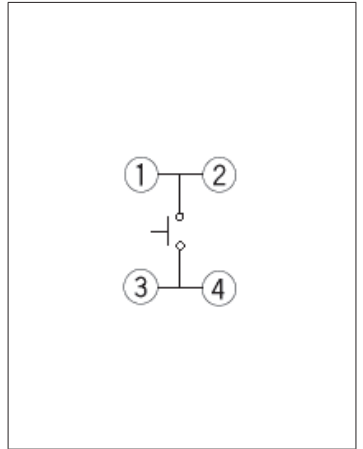

Viewed from switch mounting face

TACT Switch™ Surface Mount Type

6.2×6.5mm (Surface Mount)

SKHM Series

Type with a height of 3.1 mm, including ground terminal options.



- Series type: Sharp feeling type
- Absolute Maximum Ratings: 50mA 12V DC
- Rating (min.): 10μA 1V DC

Applications: Energy_Industrial: Industrial equipment
 Home: Major home appliances, Office equipment
 Audio_TV: Visual

Product List

Products No.	Operating direction	Operating force (N)	Travel (mm)	Operating life (cycles)	Initial contact resistance	Dimensions (W×D×H) (mm)	Water-proof	Dust-proof	Automotive	Drawing No.
SKHMQKK010	Top push	0.98	0.25	500,000	100mΩ max.	6.2×6.5×3.1	—	—	—	1
SKHMQLK010	Top push	1.57	0.25	300,000	100mΩ max.	6.2×6.5×3.1	—	—	—	
SKHMQMK010	Top push	2.35	0.25	200,000	100mΩ max.	6.2×6.5×3.1	—	—	—	

⚠ Note

1. This catalog shows only outline specifications. When using the products, please obtain formal specifications for supply.
2. Please place purchase orders for taping products per minimum order unit (1 reel or a case).

Packing Specifications

Taping

Number of packages (pcs.)			Tape width (mm)	Export package measurements (mm)
1 reel	1 case / Japan	1 case / export packing		
3,000	24,000	24,000	16	395 x 395 x 205

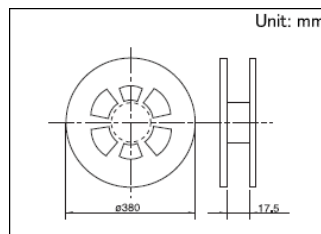

Drawing No. 1

Dimensions

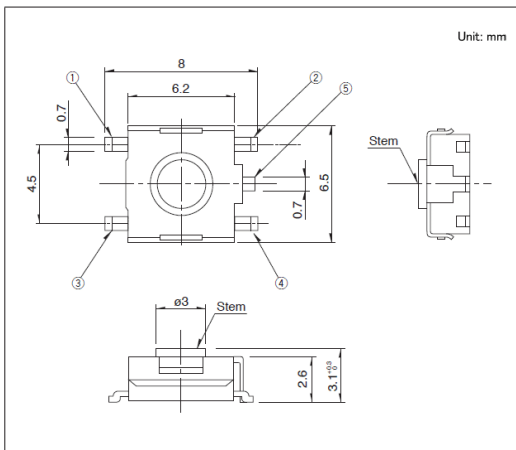

Land Dimensions

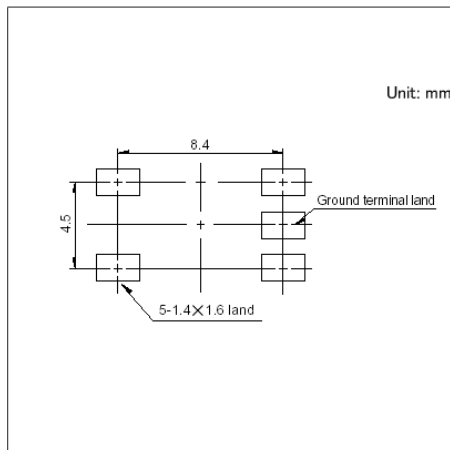

Circuit Diagram

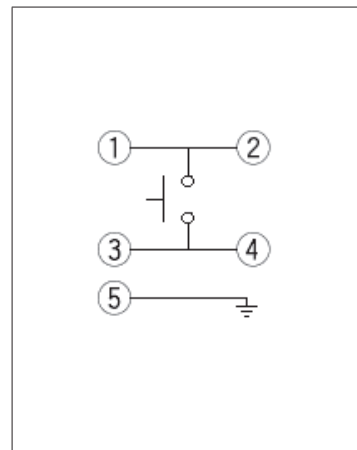

Viewed from switch mounting face

TACT Switch™ Surface Mount Type

6.2×6.3mm (Surface Mount)

SKHU Series

Wide variety including dust-proof types.

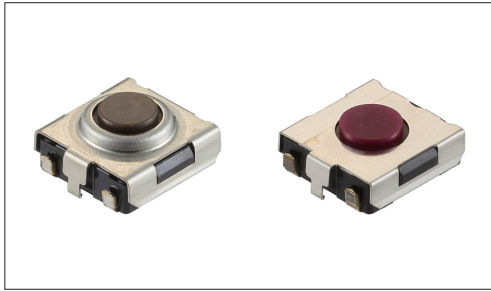

Automotive

Dust-proof Type

※Please check the product list for compatible products

- Series type: Sharp feeling type
- Absolute Maximum Ratings: 50mA 12V DC
- Rating (min.): 10μA 1V DC

Applications: Energy_Industrial: Industrial equipment
 Home: Major home appliances, Office equipment
 Audio_TV: Visual
 Automotive: Navigation/audio systems, HVAC

Product List

Products No.	Type	Operating direction	Operating force (N)	Travel (mm)	Operating life (cycles)	Initial contact resistance	Dimensions (W×D×H) (mm)	Water-proof	Dust-proof	Automotive	Drawing No.
SKHUAKE010	Top push type	Top push	0.98	0.25	300,000	100mΩ max.	6.2×6.3×2.5	—	—	●	1
SKHUALE010		Top push	1.57	0.25	300,000	100mΩ max.	6.2×6.3×2.5	—	—	●	
SKHUAEME010		Top push	2.55	0.25	100,000	100mΩ max.	6.2×6.3×2.5	—	—	●	
SKHUPKE010	With ground terminal type	Top push	0.98	0.25	300,000	100mΩ max.	6.2×6.3×2.5	—	—	●	2
SKHUPLE010		Top push	1.57	0.25	300,000	100mΩ max.	6.2×6.3×2.5	—	—	●	
SKHUPME010		Top push	2.55	0.25	100,000	100mΩ max.	6.2×6.3×2.5	—	—	●	
SKHUBHE010	Dust-proof type	Top push	1.57	0.25	50,000	100mΩ max.	6.2×6.3×3.1	—	●	●	3
SKHUQHE010	Dust-proof and with ground terminal type	Top push	1.57	0.25	50,000	100mΩ max.	6.2×6.3×3.1	—	●	●	4
SKHUQGE010		Top push	2.55	0.25	50,000	100mΩ max.	6.2×6.3×3.1	—	●	●	

Note

1. This catalog shows only outline specifications. When using the products, please obtain formal specifications for supply.
2. Please place purchase orders for taping products per minimum order unit (1 reel or a case).

Packing Specifications

Taping

Number of packages (pcs.)			Tape width (mm)	Export package measurements (mm)
1 reel	1 case / Japan	1 case / export packing		
3,000	30,000	30,000	12	395 x 395 x 205

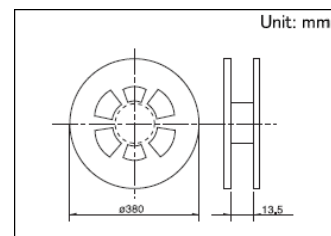

TACT Switch™ Surface Mount Type

6.2x6.3mm (Surface Mount)

SKHU Series

Drawing No.1

■ Dimensions

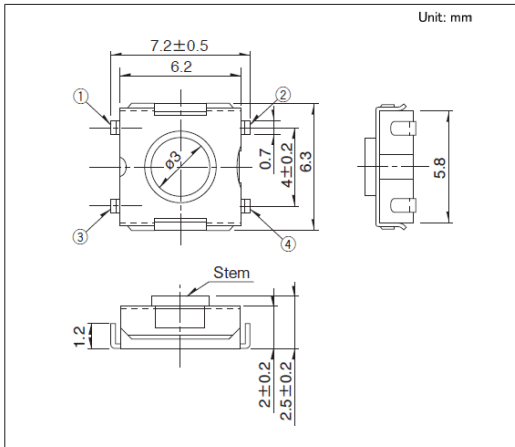

■ Land Dimensions

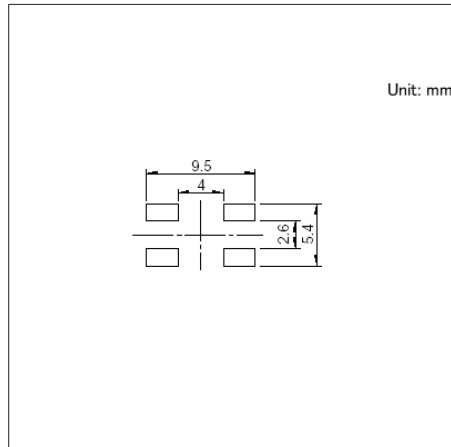

■ Circuit Diagram

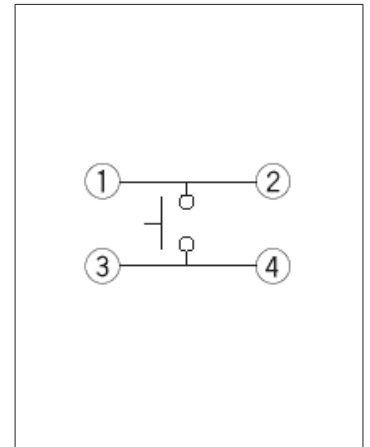

Viewed from switch mounting face

Drawing No.2

■ Dimensions

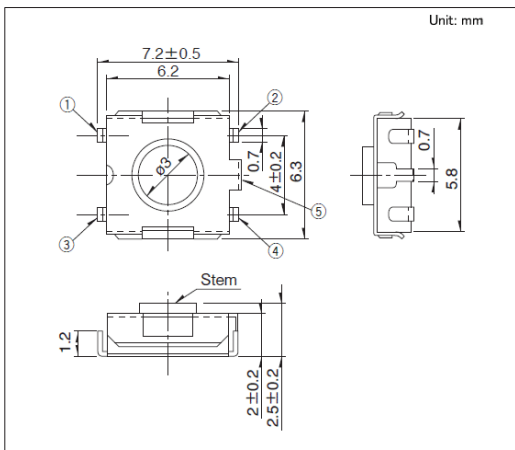

■ Land Dimensions

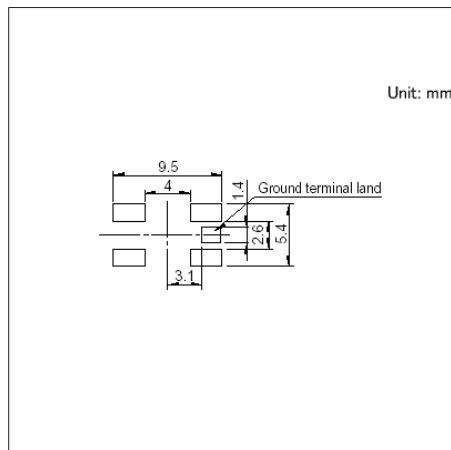

■ Circuit Diagram

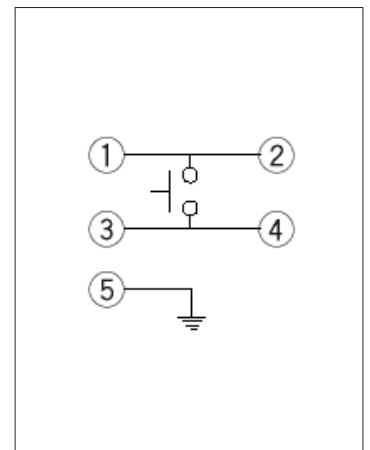

Viewed from switch mounting face

Drawing No.3

■ Dimensions

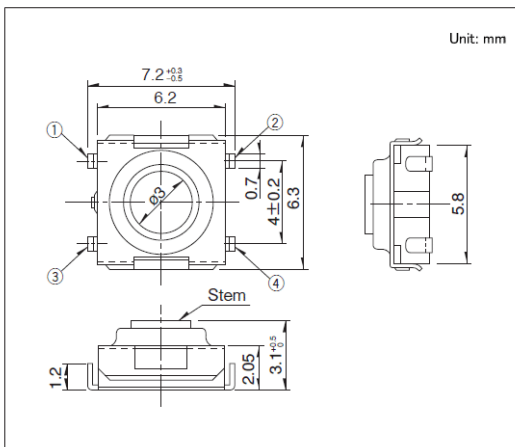

■ Land Dimensions

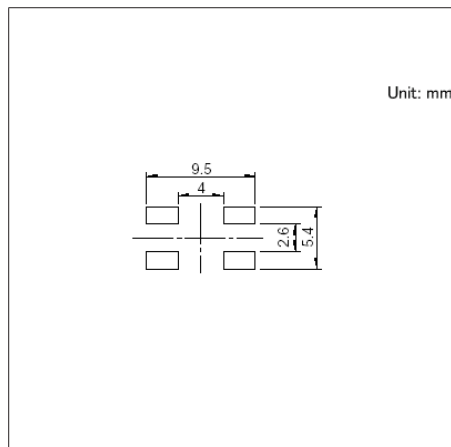

■ Circuit Diagram

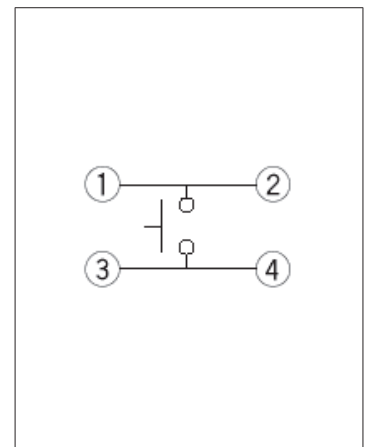

Viewed from switch mounting face

TACT Switch™ Surface Mount Type

6.2×6.3mm (Surface Mount)

SKHU Series

Drawing No.4

■ Dimensions

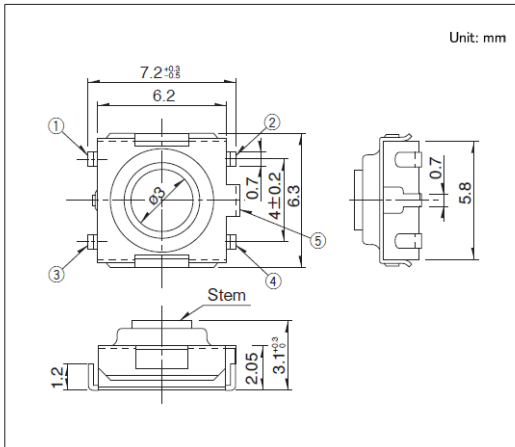

■ Land Dimensions

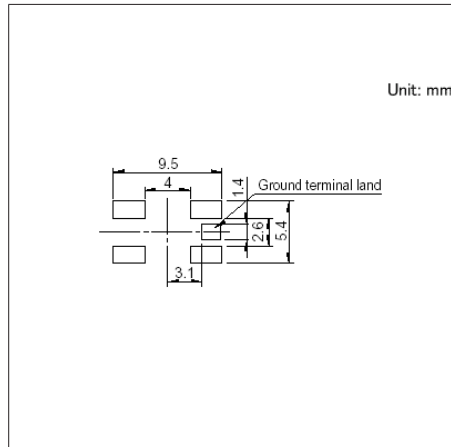

■ Circuit Diagram

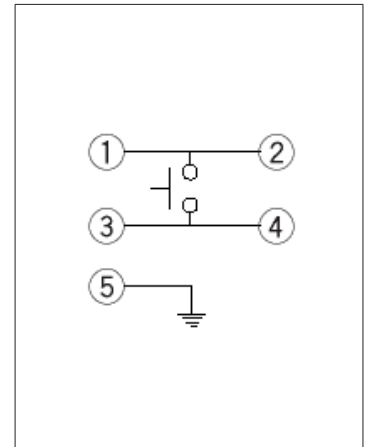

Viewed from switch mounting face

TACT Switch™ Surface Mount Type

8.5mm Square (Surface Mount) SKST Series

Type with a height of 3.95mm, delivering a refined operation feel with a mid-stroke.

 Automotive



- Series type: Sharp feeling type
- Absolute Maximum Ratings: 50mA 16V DC
- Rating (min.): 10μA 1V DC

Applications: Automotive: Navigation/audio systems, HVAC, Overhead consoles, Steering, Shifter

Product List

Products No.	Operating direction	Operating force (N)	Travel (mm)	Operating life (cycles)	Initial contact resistance	Dimensions (W×D×H) (mm)	Water-proof	Dust-proof	Automotive	Drawing No.
SKSTABE010	Top push	4.0	0.75	500,000	100mΩ max.	8.5×8.5×3.95	—	—	●	1
SKSTAAE010	Top push	4.0	0.9	500,000	100mΩ max.	8.5×8.5×3.95	—	—	●	
SKSTAHE010	Top push	4.5	0.9	1,000,000	100mΩ max.	8.5×8.5×3.95	—	—	●	
SKSTAJE010	Top push	7.0	0.9	1,000,000	100mΩ max.	8.5×8.5×3.95	—	—	●	
SKSTACE010	Top push	7.0	0.9	500,000	500mΩ max.	8.5×8.5×3.95	—	—	●	
SKSTADE010	Top push	10.0	0.9	200,000	100mΩ max.	8.5×8.5×3.95	—	—	●	

Note

1. This catalog shows only outline specifications. When using the products, please obtain formal specifications for supply.
2. Please place purchase orders for taping products per minimum order unit (1 reel or a case).

Packing Specifications

Taping

Number of packages (pcs.)			Tape width (mm)	Export package measurements (mm)
1 reel	1 case / Japan	1 case / export packing		
1,500	9,000	9,000	24	395 x 395 x 205

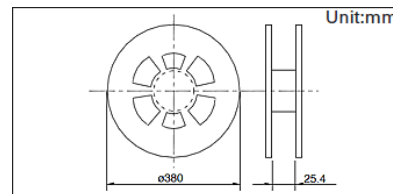

TACT Switch™ Surface Mount Type

8.5mm Square (Surface Mount)

SKST Series

Drawing No.1

■ Dimensions

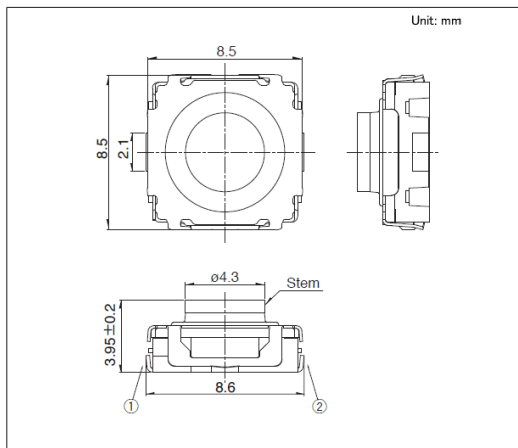

■ Land Dimensions

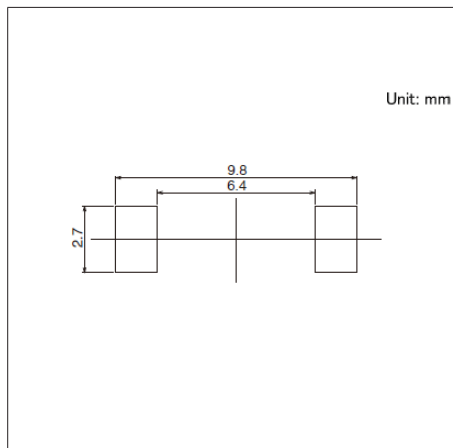

■ Circuit Diagram

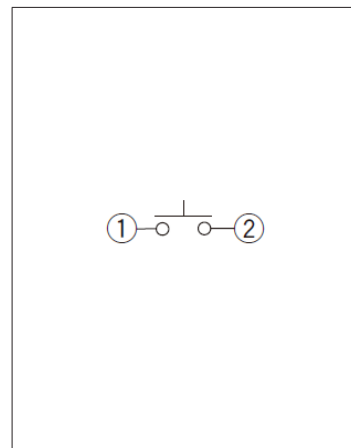

Viewed from switch mounting face

TACT Switch™ Surface Mount Type

3.9x2.9mm Side Push (Surface Mount)

SKTD Series

Type with a height of 1.55mm, compliant with IP6X equivalent/IPX7.



Water-proof Type

Dust-proof Type

- Series type: Sharp feeling type
- Absolute Maximum Ratings: 50mA 12V DC
- Rating (min.): 10μA 1V DC

Applications: Mobile: Smartphones, tablets, Headsets, wearables,
Notebooks, peripherals
Healthcare: Healthcare equipment

■ Product List

Products No.	Operating direction	Operating force (N)	Travel (mm)	Operating life (cycles)	Initial contact resistance	Dimensions (WxDxH) (mm)	Water-proof	Dust-proof	Water-proof & Dust-proof	Automotive	Drawing No.
SKTDLDE010	Side push	1.6	0.15	200,000	500mΩ max.	3.9x2.9x1.55	●	●	IP6X equivalent/IPX7	—	1
SKTDLGE010	Side push	2.0	0.15	200,000	500mΩ max.	3.9x2.9x1.55	●	●	IP6X equivalent/IPX7	—	

Note

1. This catalog shows only outline specifications. When using the products, please obtain formal specifications for supply.
2. Please place purchase orders for taping products per minimum order unit (1 reel or a case).
3. Protective structure :
Assumes the switch is left alone without being operated. Under the specified conditions, dust and water ingress with a significant impact on the switch's on-off function is prevented.
IP6X equivalent/IPX7 dust and water resistance is guaranteed for the switch alone and performance may not be guaranteed depending on the mounting conditions and usage.

■ Packing Specifications

Taping

Number of packages (pcs.)			Tape width (mm)	Export package measurements (mm)
1 reel	1 case / Japan	1 case / export packing		
4,500	45,000	45,000	12	395 x 395 x 205

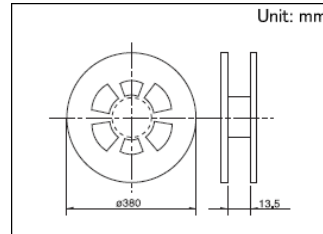

Drawing No. 1

■ Dimensions

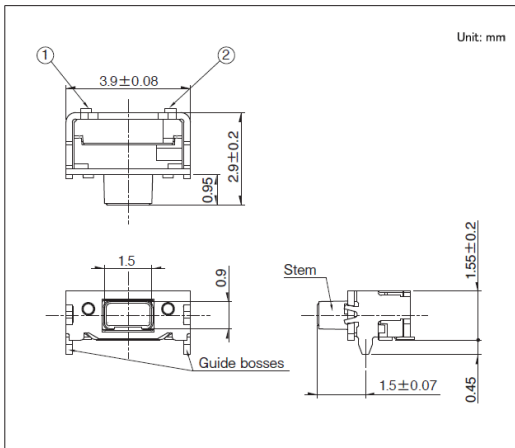

■ Land Dimensions

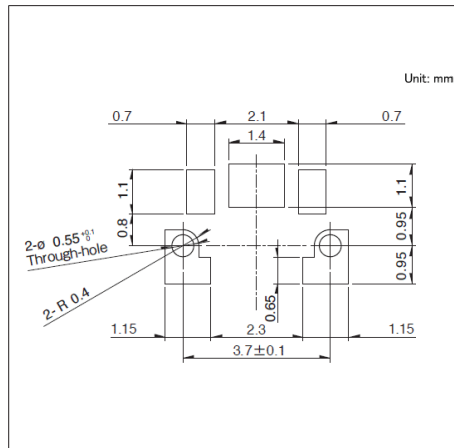

■ Circuit Diagram

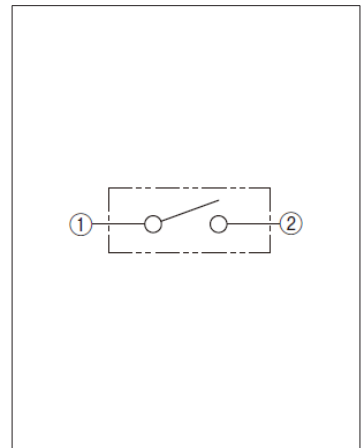

Viewed from switch mounting face

TACT Switch™ Surface Mount Type

6.2×3.0mm Side Push (Surface Mount)

SKSN Series

Mid-mount type with a mounting height of 1.35mm from the board surface, including automotive-compatible variants.



 Automotive

※Please check the product list for compatible products

- Series type: Sharp feeling type
- Absolute Maximum Ratings: 50mA 12V DC
- Rating (min.): 10μA 1V DC

Applications: Mobile: Headsets, wearables, Notebooks, peripherals
 Energy_Industrial: Robots, drones
 Game: Home handheld consoles
 Healthcare: Healthcare equipment, Analysis, test equipment
 Automotive: Remote Keyless Entry (RKE)

Product List

Products No.	Operating direction	Operating force (N)	Travel (mm)	Operating life (cycles)	Initial contact resistance	Dimensions (W×D×H) (mm)	Water-proof	Dust-proof	Automotive	Drawing No.
SKSNLME010	Side push	1.6	0.15	1,000,000	100mΩ max.	7.5×3.0×3.5	—	—	—	1
SKSNLAE010	Side push	2.4	0.2	500,000	100mΩ max.	6.2×3.0×3.5	—	—	—	2
SKSNLKE010	Side push	4.5	0.2	100,000	100mΩ max.	6.2×3.0×3.5	—	—	●	
SKSNLHE010	Side push	5.0	0.2	100,000	100mΩ max.	6.2×3.0×3.5	—	—	●	
SKSNLPE010	Side push	1.6	0.23	1,000,000	500mΩ max.	7.5×4.07×3.5	—	—	—	3

Note

1. This catalog shows only outline specifications. When using the products, please obtain formal specifications for supply.
2. Please place purchase orders for taping products per minimum order unit (1 reel or a case).

Packing Specifications

Taping

Products No.	Number of packages(pcs.)			Tape width (mm)	Export package measurements (mm)
	1 reel	1 case / Japan	1 case / export packing		
SKSNLME010	1,900	19,000	19,000	12	395 x 395 x 205
SKSNLAE010 SKSNLKE010 SKSNLHE010	2,500	25,000	25,000	12	395 x 395 x 205
SKSNLPE010	1,200	12,000	12,000	12	395×395×205

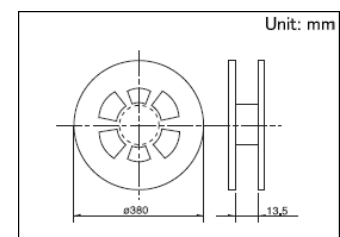

TACT Switch™ Surface Mount Type
6.2×3.0mm Side Push (Surface Mount)
SKSN Series

Drawing No.1

■ Dimensions

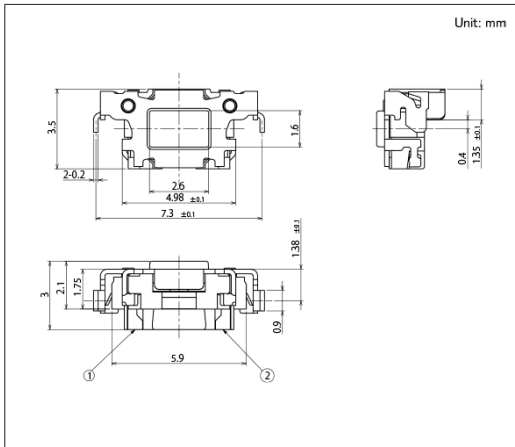

■ Land Dimensions

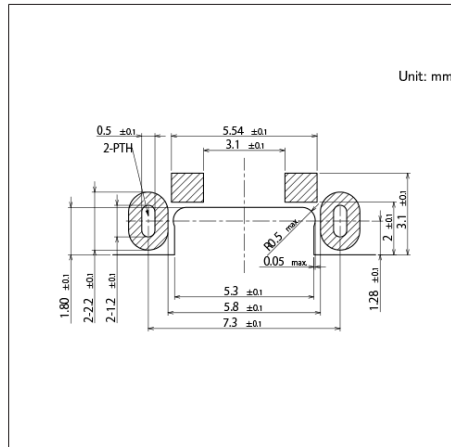

■ Circuit Diagram

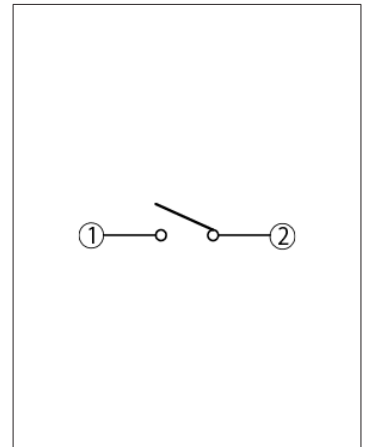

Viewed from switch mounting face

Drawing No.2

■ Dimensions

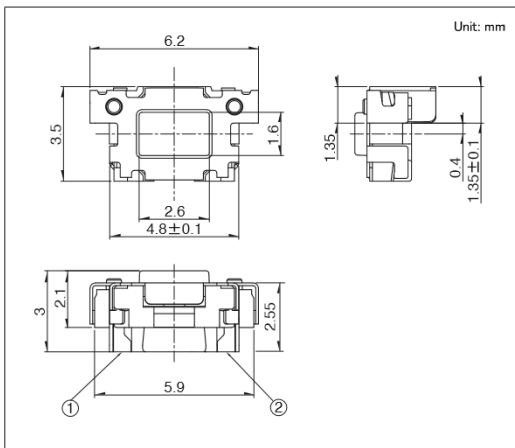

■ Land Dimensions

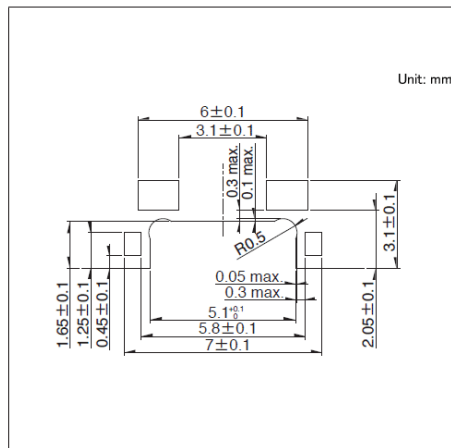

■ Circuit Diagram

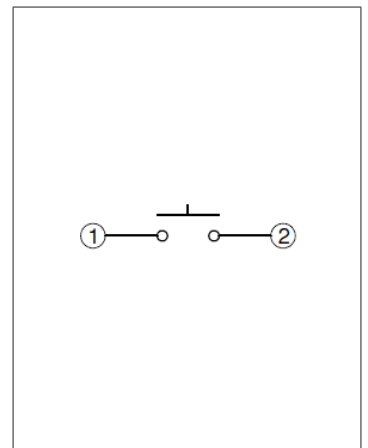

Viewed from switch mounting face

Drawing No.3

■ Dimensions

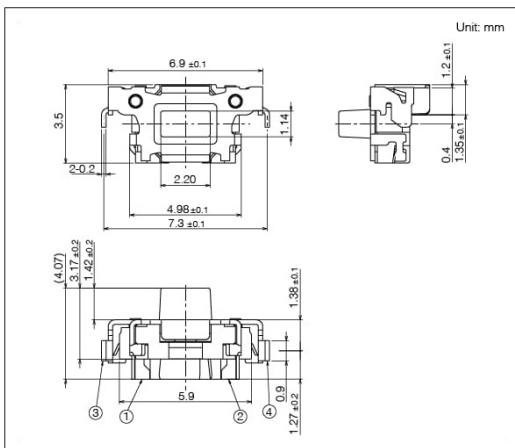

■ Land Dimensions

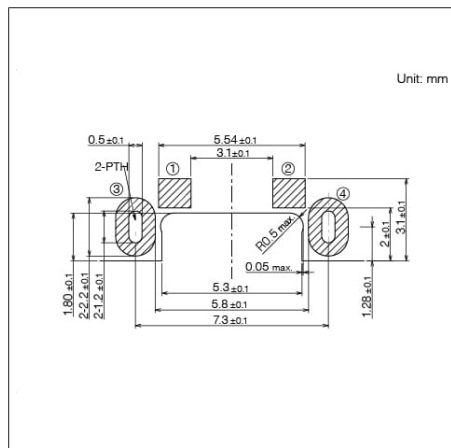

■ Circuit Diagram

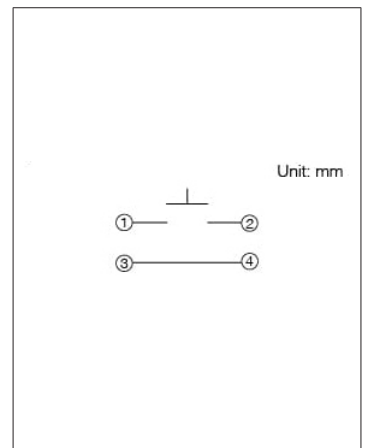

Viewed from switch mounting face

TACT Switch™ Surface Mount Type

4.5×2.6mm Side Push (Surface Mount)

SKSL Series

Half-mount type with a mounting height of 1.6mm from the board surface.



Automotive

※Please check the product list for compatible products

- Series type: Sharp feeling type
- Absolute Maximum Ratings: 50mA 12V DC
- Rating (min.): 10μA 1V DC

Applications: Mobile: Smartphones, tablets, Smartphones, tablets,
Notebooks, peripherals
Automotive: Remote Keyless Entry (RKE)

■ Product List

Products No.	Operating direction	Operating force (N)	Travel (mm)	Operating life (cycles)	Initial contact resistance	Dimensions (W×D×H) (mm)	Water-proof	Dust-proof	Automotive	Drawing No.
SKSLLAE010	Side push	1.6	0.15	600,000	500mΩ max.	4.5×2.6×2.2	—	—	—	1
SKSLLE010	Side push	2.2	0.15	600,000	500mΩ max.	4.5×2.6×2.2	—	—	—	
SKSLLE010	Side push	3.5	0.15	100,000	500mΩ max.	4.5×2.6×2.2	—	—	●	

Note

1. This catalog shows only outline specifications. When using the products, please obtain formal specifications for supply.
2. Please place purchase orders for taping products per minimum order unit (1 reel or a case).

■ Packing Specifications

Taping

Number of packages (pcs.)			Tape width (mm)	Export package measurements (mm)
1 reel	1 case / Japan	1 case / export packing		
4,400	44,000	44,000	12	395 x 395 x 205

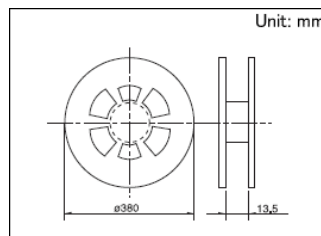

Drawing No. 1

■ Dimensions

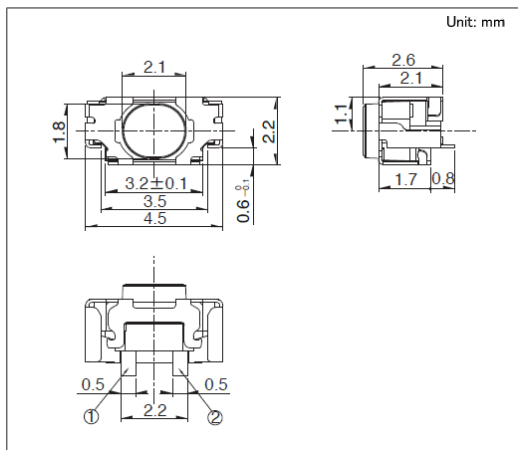

■ Land Dimensions

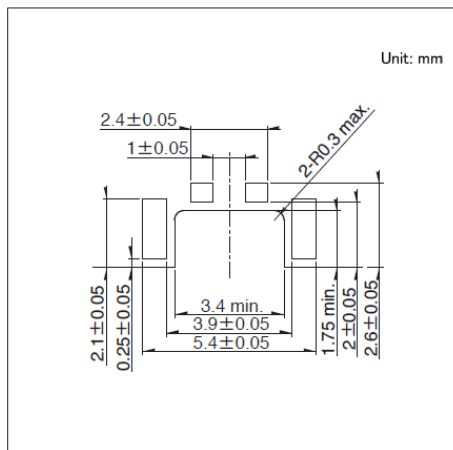

■ Circuit Diagram

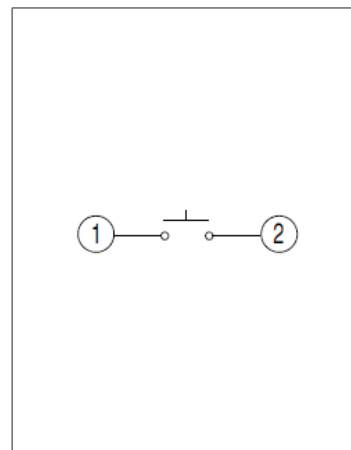

Viewed from switch mounting face

TACT Switch™ Surface Mount Type

3.5×3.55mm Side Push (Surface Mount)

SKSC Series

Half-mount type with excellent soldering strength, compact and thin (1.25mm), including ground terminal options.

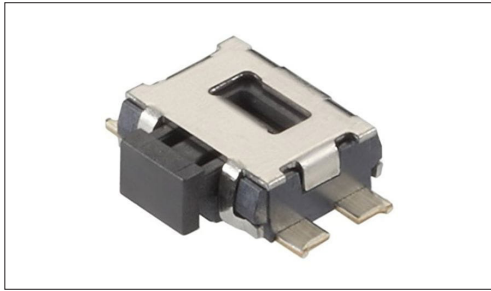

- Series type: Sharp feeling type
- Absolute Maximum Ratings: 50mA 12V DC
- Rating (min.): 10μA 1V DC

Applications: Mobile: Smartphones, tablets, Smartphones, tablets, Notebooks, peripherals

■ Product List

Products No.	Type	Operating direction	Operating force (N)	Travel (mm)	Operating life (cycles)	Initial contact resistance	Guide bosses	Dimensions (W×D×H) (mm)	Water-proof	Dust-proof	Automotive	Drawing No.
SKSCLCE010	Side push type	Side push	1.6	0.2	100,000	100mΩ max.	Without	3.5×3.55×1.25	—	—	—	1
SKSCLAE010		Side push	2.2	0.2	100,000	100mΩ max.	Without	3.5×3.55×1.25	—	—	—	
SKSCLDE010		Side push	1.6	0.2	100,000	100mΩ max.	With	3.5×3.55×1.25	—	—	—	2
SKSCLBE010		Side push	2.2	0.2	100,000	100mΩ max.	With	3.5×3.55×1.25	—	—	—	
SKSCPCE010	With ground terminal type	Side push	1.6	0.2	100,000	100mΩ max.	Without	3.5×3.55×1.25	—	—	—	3
SKSCP AE010		Side push	2.2	0.2	100,000	100mΩ max.	Without	3.5×3.55×1.25	—	—	—	
SKSCPDE010		Side push	1.6	0.2	100,000	100mΩ max.	With	3.5×3.55×1.25	—	—	—	4
SKSCPBE010		Side push	2.2	0.2	100,000	100mΩ max.	With	3.5×3.55×1.25	—	—	—	

⚠ Note

1. This catalog shows only outline specifications. When using the products, please obtain formal specifications for supply.
2. Please place purchase orders for taping products per minimum order unit (1 reel or a case).

■ Packing Specifications

Taping

Number of packages (pcs.)			Tape width (mm)	Export package measurements (mm)
1 reel	1 case / Japan	1 case / export packing		
5,000	50,000	50,000	12	395 x 395 x 205

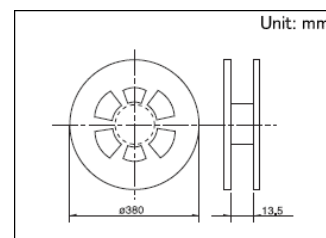

TACT Switch™ Surface Mount Type
3.5×3.5mm Side Push (Surface Mount)
SKSC Series

Drawing No.1

■ Dimensions

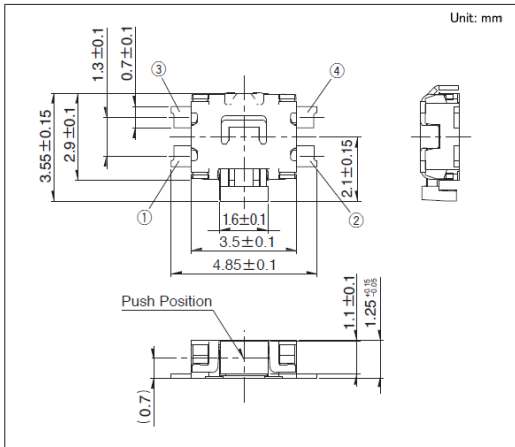

■ Land Dimensions

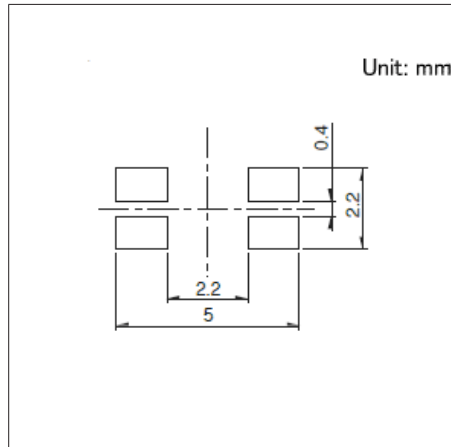

■ Circuit Diagram

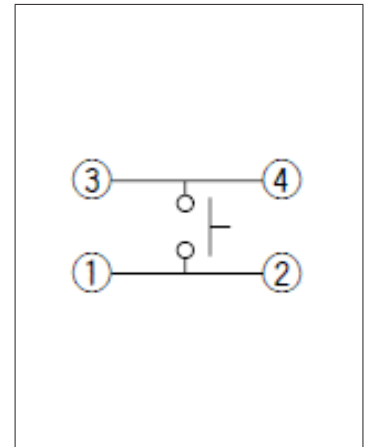

Viewed from switch mounting face

Drawing No.2

■ Dimensions

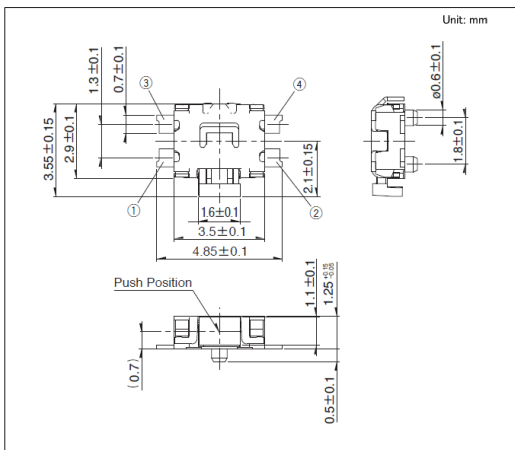

■ Land Dimensions

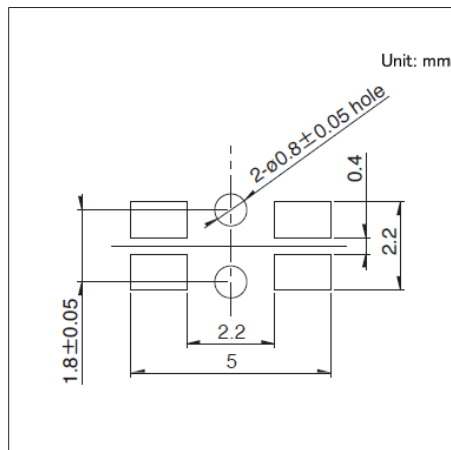

■ Circuit Diagram

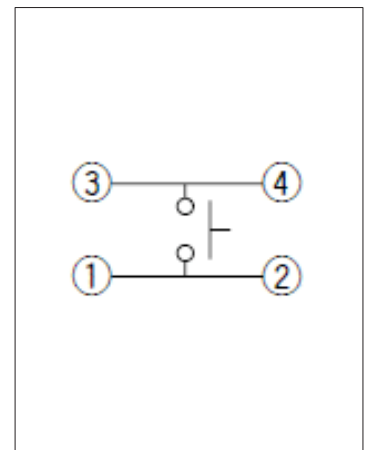

Viewed from switch mounting face

Drawing No.3

■ Dimensions

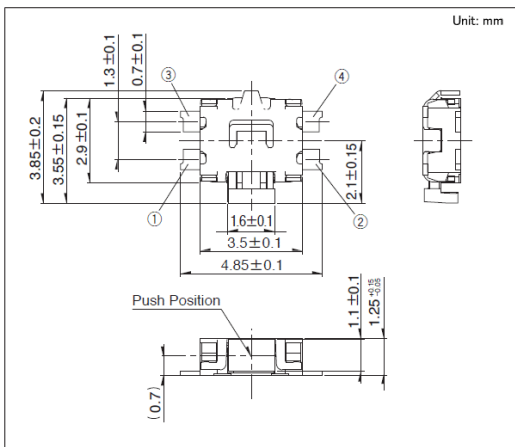

■ Land Dimensions

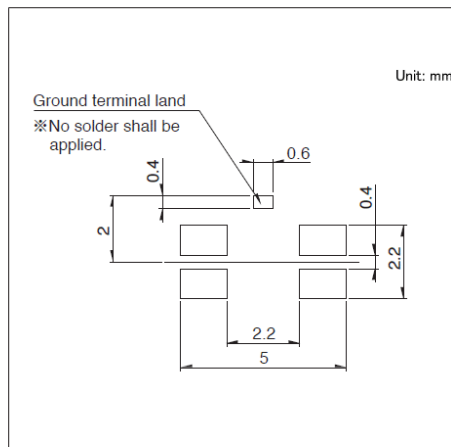

■ Circuit Diagram

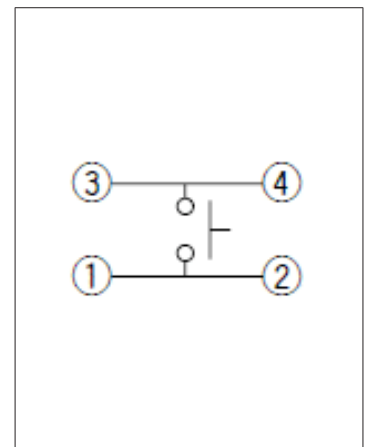

Viewed from switch mounting face

TACT Switch™ Surface Mount Type
3.5x3.55mm Side Push (Surface Mount)
SKSC Series

Drawing No.4

■ Dimensions

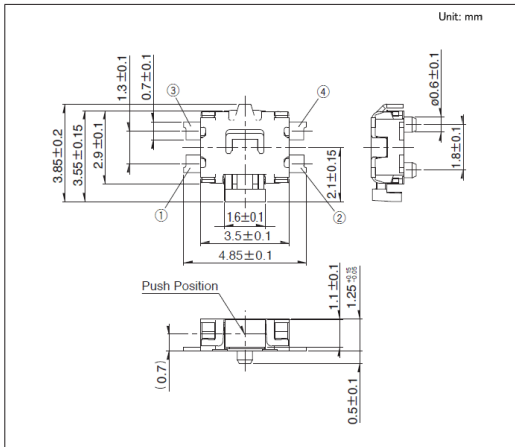

■ Land Dimensions

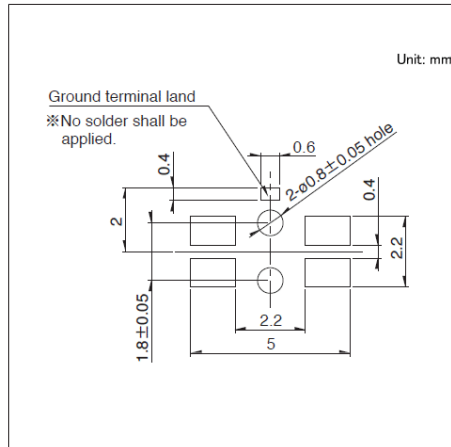

■ Circuit Diagram

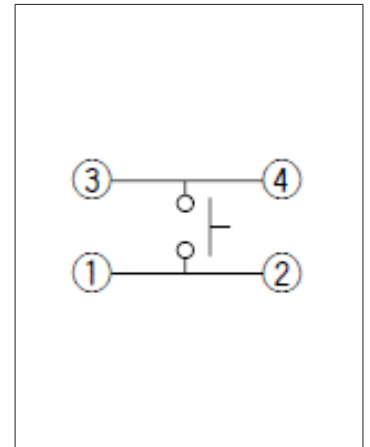

Viewed from switch mounting face

TACT Switch™ Surface Mount Type

4.5×3.4mm Side Push (Surface Mount)

SKRT Series

Side-push type with excellent soldering strength and good operation feel.



- Series type: Sharp feeling type
- Absolute Maximum Ratings: 50mA 12V DC
- Rating (min.): 10μA 1V DC

Applications: Mobile: Headsets, wearables

Product List

Products No.	Operating direction	Operating force (N)	Travel (mm)	Operating life (cycles)	Initial contact resistance	Guide bosses	Dimensions (W×D×H) (mm)	Water-proof	Dust-proof	Automotive	Drawing No.
SKRTLAE010	Side push	1.6	0.2	100,000	500mΩ max.	With	4.5×3.4×3.3	—	—	—	1
SKRTLBE010	Side push	1.6	0.2	100,000	500mΩ max.	Without	4.5×3.4×3.3	—	—	—	2

Note

1. This catalog shows only outline specifications. When using the products, please obtain formal specifications for supply.
2. Please place purchase orders for taping products per minimum order unit (1 reel or a case).

Packing Specifications

Taping

Number of packages (pcs.)			Tape width (mm)	Export package measurements (mm)
1 reel	1 case / Japan	1 case / export packing		
3,000	30,000	30,000	12	395 x 395 x 205

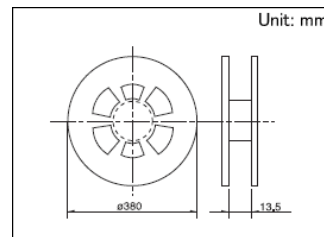

Drawing No. 1

Dimensions

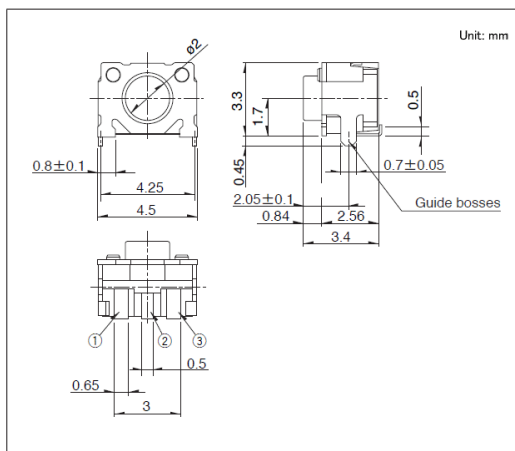

Land Dimensions

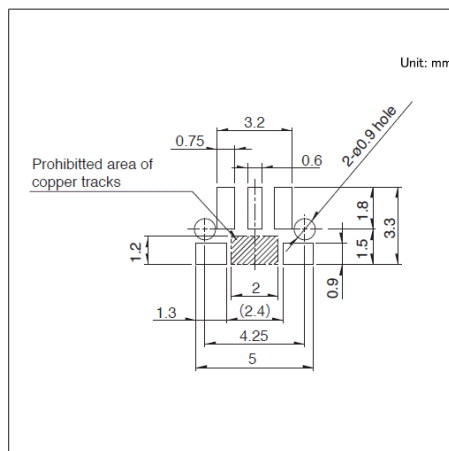

Circuit Diagram

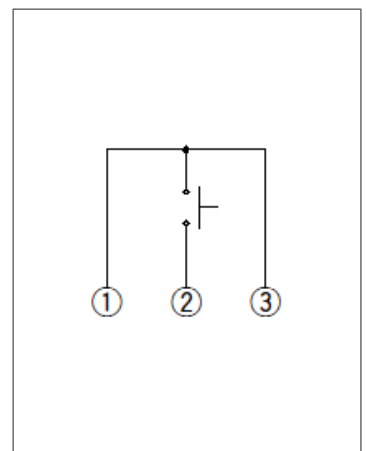

Viewed from switch mounting face

TACT Switch™ Surface Mount Type

4.5×3.4mm Side Push (Surface Mount)

SKRT Series

Drawing No.2

■ Dimensions

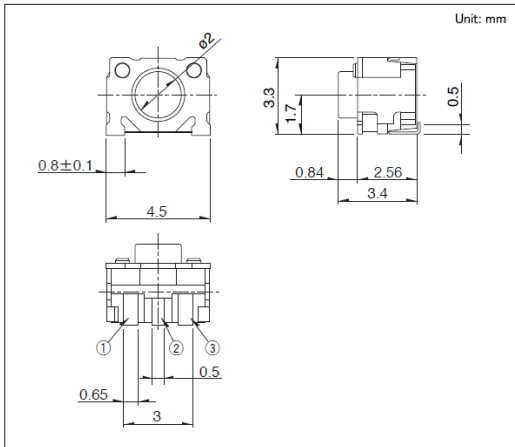

■ Land Dimensions

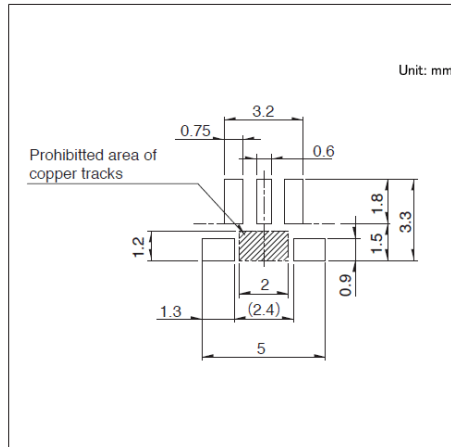

■ Circuit Diagram

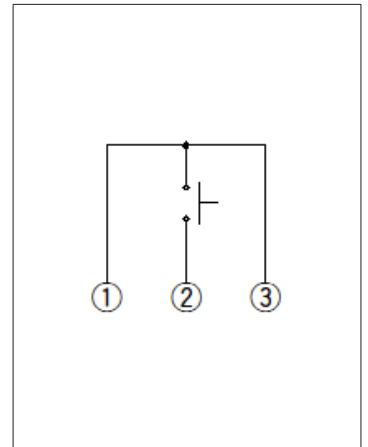

Viewed from switch mounting face

TACT Switch™ Surface Mount Type

4.8x3.25mm Side Push (Surface Mount)

SKSJ Series

Long-life half-mount type with excellent soldering strength, capable of 1 million operation cycles.

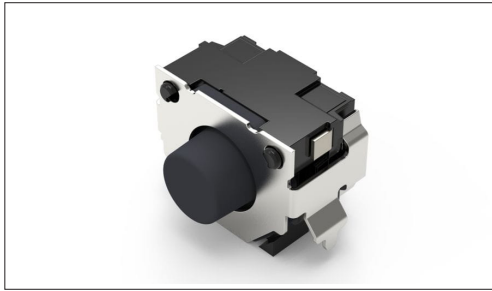

- Series type: Sharp feeling type
- Absolute Maximum Ratings: 50mA 12V DC
- Rating (min.): 10μA 1V DC

Applications: Mobile: Notebooks, peripherals, Headsets, wearables
 Game: Home handheld consoles
 Mobile: Headsets, wearables
 Healthcare: Healthcare equipment

Product List

Products No.	Operating direction	Operating force (N)	Travel (mm)	Operating life (cycles)	Initial contact resistance	Dimensions (WxDxH) (mm)	Water-proof	Dust-proof	Automotive	Drawing No.
SKSJLEE010	Side push	1.6	0.2	1,000,000	500mΩ max.	4.8x3.25x3.3	—	—	—	1

Note

1. This catalog shows only outline specifications. When using the products, please obtain formal specifications for supply.
2. Please place purchase orders for taping products per minimum order unit (1 reel or a case).

Packing Specifications

Taping

Number of packages (pcs.)			Tape width (mm)	Export package measurements (mm)
1 reel	1 case / Japan	1 case / export packing		
3,000	30,000	30,000	12	395 x 395 x 205

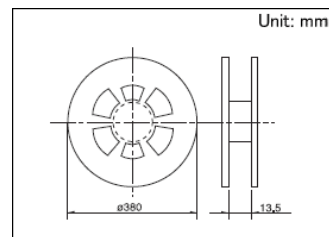

Drawing No. 1

Dimensions

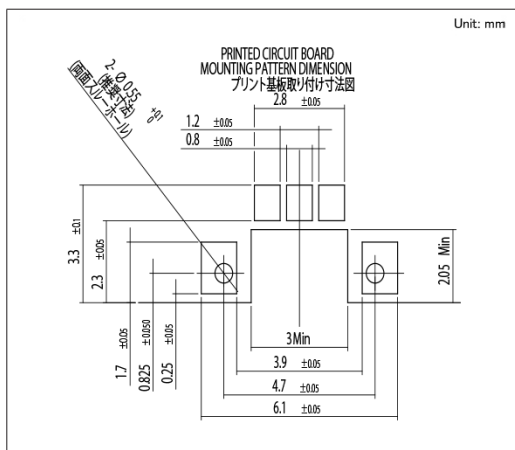

Land Dimensions

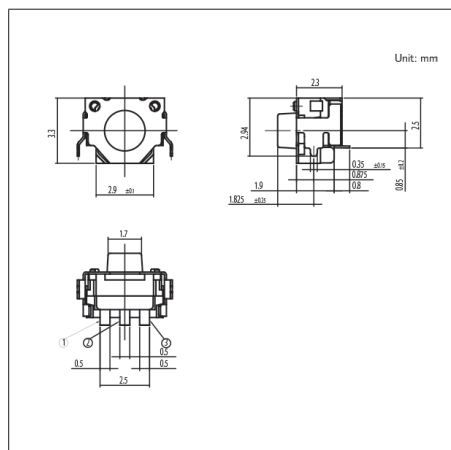

Circuit Diagram

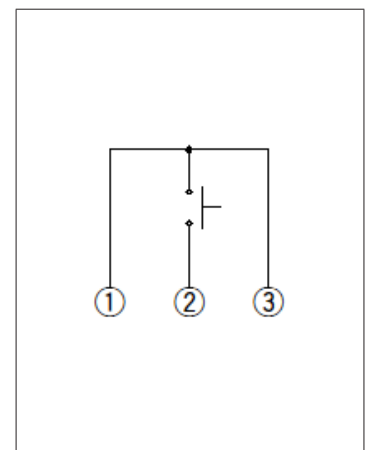

Viewed from switch mounting face

TACT Switch™ Surface Mount Type

6.0×5.9mm Low Contact Resistance (Surface Mount)

SKPS Series

Long-stroke, soft-feel type with 1.05mm travel, capable of 300,000 operation cycles.

 Automotive



- Series type: Soft feeling type
- Absolute Maximum Ratings: 50mA 16V DC
- Rating (min.): 10μA 1V DC

Applications: Automotive: Navigation/audio systems, HVAC, Overhead consoles, Steering, Shifter

Product List

Products No.	Operating direction	Operating force (N)	Travel (mm)	Operating life (cycles)	Initial contact resistance	Dimensions (W×D×H) (mm)	Water-proof	Dust-proof	Automotive	Drawing No.
SKPSAEE010	Top push	2.5	1.05	300,000	100mΩ max.	5.9×6.0×5.0	—	—	●	1
SKPSACE010	Top push	3.0	1.05	300,000	100mΩ max.	5.9×6.0×5.0	—	—	●	
SKPSADE010	Top push	3.3	1.05	300,000	100mΩ max.	5.9×6.0×5.0	—	—	●	
SKPSAAE010	Top push	3.6	1.05	300,000	100mΩ max.	5.9×6.0×5.0	—	—	●	

Note

1. This catalog shows only outline specifications. When using the products, please obtain formal specifications for supply.
2. Please place purchase orders for taping products per minimum order unit (1 reel or a case).

Packing Specifications

Taping

Number of packages (pcs.)			Tape width (mm)	Export package measurements (mm)
1 reel	1 case / Japan	1 case / export packing		
2,000	20,000	20,000	12	395 x 395 x 205

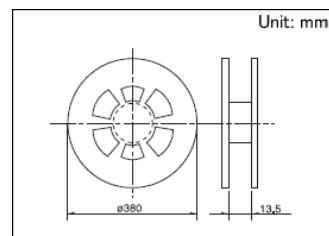

Drawing No.1

Dimensions

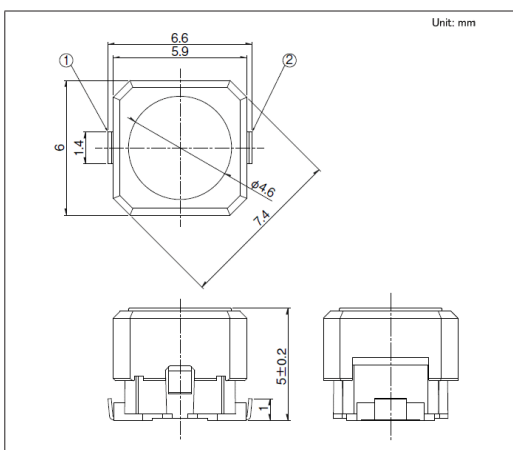

Land Dimensions

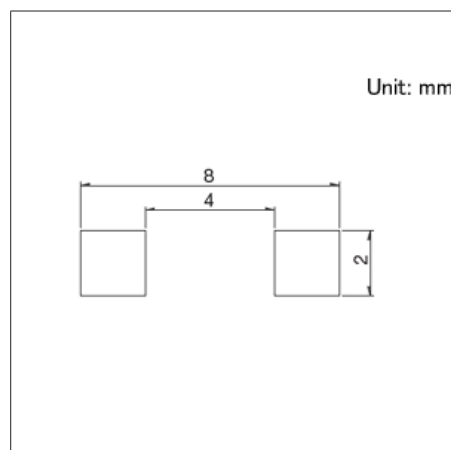

Circuit Diagram

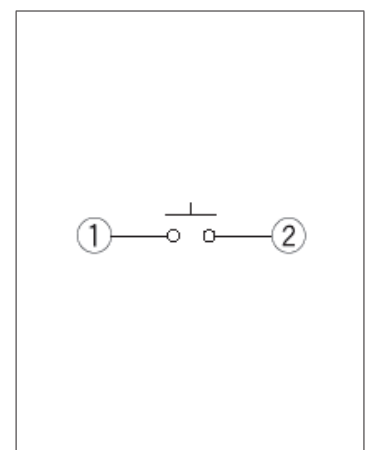

Viewed from switch mounting face

TACT Switch™ Surface Mount Type

6.0x5.9mm Low Contact Resistance (Surface Mount)

SKPM Series

Long-stroke, soft-feel type with a 1.3mm travel, featuring metal contacts for low contact resistance.

 Automotive



- Series type: Soft feeling type
- Absolute Maximum Ratings: 50mA 16V DC
- Rating (min.): 10μA 1V DC

Applications: Audio_TV: Pro audio
Automotive: Navigation/audio systems, HVAC, Overhead consoles, Steering, Shifter

Product List

Products No.	Operating direction	Operating force (N)	Travel (mm)	Operating life (cycles)	Initial contact resistance	Dimensions (WxDxH) (mm)	Water-proof	Dust-proof	Automotive	Drawing No.
SKPMAME010	Top push	1.57	1.3	100,000	100mΩ max.	5.9x6.0x5.0	—	—	●	1
SKPMANE010	Top push	1.96	1.3	100,000	100mΩ max.	5.9x6.0x5.0	—	—	●	
SKPMAPE010	Top push	2.45	1.3	100,000	100mΩ max.	5.9x6.0x5.0	—	—	●	
SKPMBHE010	Top push	3.0	1.3	100,000	100mΩ max.	5.9x6.0x5.0	—	—	●	

Note

1. This catalog shows only outline specifications. When using the products, please obtain formal specifications for supply.
2. Please place purchase orders for taping products per minimum order unit (1 reel or a case).

Packing Specifications

Taping

Number of packages (pcs.)			Tape width (mm)	Export package measurements (mm)
1 reel	1 case / Japan	1 case / export packing		
2,000	20,000	20,000	12	395 x 395 x 205

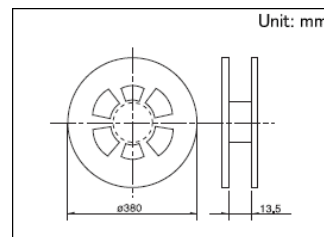

Drawing No.1

Dimensions

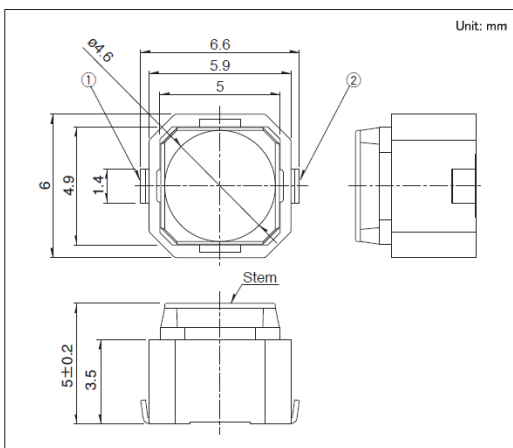

Land Dimensions

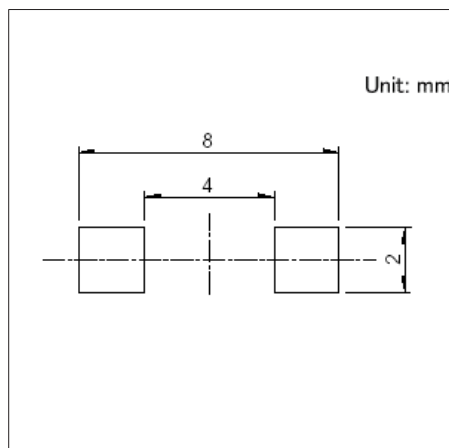

Circuit Diagram

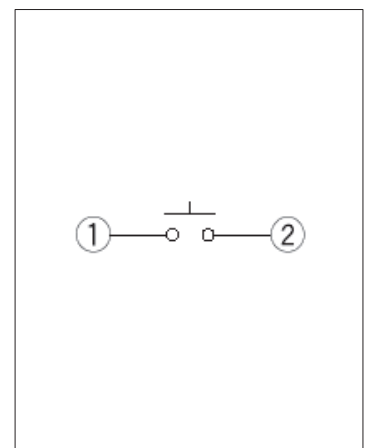

Viewed from switch mounting face

TACT Switch™ Surface Mount Type

7.5×7.8mm High Operation Force, Low Contact Resistance (Surface Mount) SKPR Series

Heavy-duty long-stroke, soft-feel type with a 1.0mm travel, featuring metal contacts for low contact resistance.



Automotive

- Series type: Soft feeling type
- Absolute Maximum Ratings: 50mA 16V DC
- Rating (min.): 10μA 1V DC

Applications: Automotive: Navigation/audio systems, HVAC, Overhead consoles, Steering, Shifter

Product List

Products No.	Operating direction	Operating force (N)	Travel (mm)	Operating life (cycles)	Initial contact resistance	Dimensions (W×D×H) (mm)	Water-proof	Dust-proof	Automotive	Drawing No.
SKPRAAE010	Top push	5.0	1.0	100,000	100mΩ max.	7.5×7.8×6.5	—	—	●	1

Note

1. This catalog shows only outline specifications. When using the products, please obtain formal specifications for supply.
2. Please place purchase orders for taping products per minimum order unit (1 reel or a case).

Packing Specifications

Taping

Number of packages (pcs.)			Tape width (mm)	Export package measurements (mm)
1 reel	1 case / Japan	1 case / export packing		
1,050	6,300	6,300	24	395 x 395 x 205

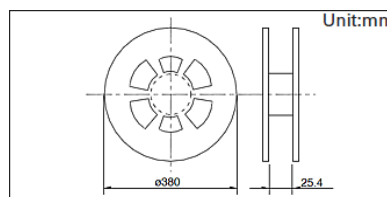

Drawing No. 1

Dimensions

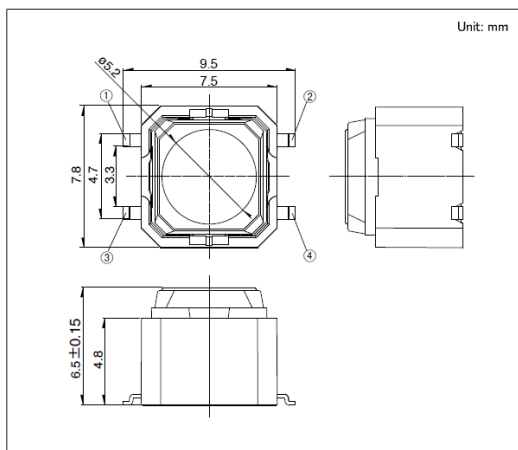

Land Dimensions

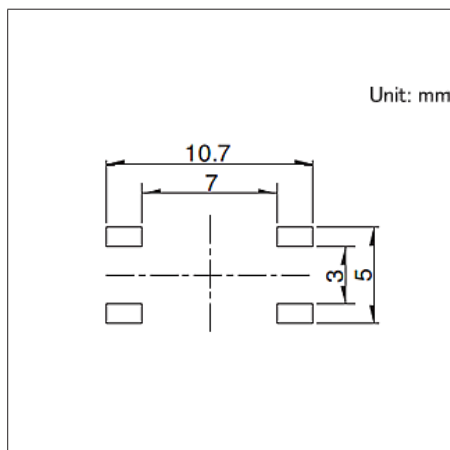

Circuit Diagram

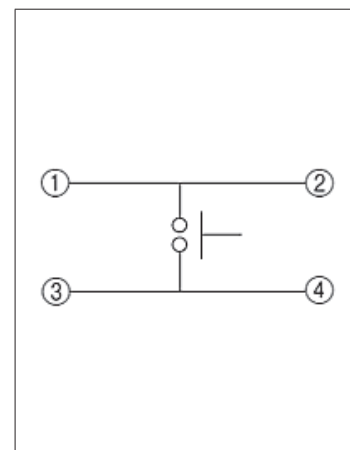

Viewed from switch mounting face

Radial Type

List of Varieties

Series		SKRC
Photo		
Operation feeling		Sharp feeling
Water-proof		●
Dust-proof		●
IP standard		In the coated state
Operating direction	Top push	●
	Side push	—
Ground terminal		—
Dimensions (mm)		φ9mm×13
Operating force (N)		1.57 2.55
Travel (mm)		0.25
Operating temperature range		-30°C to +85°C
Electrical performance	Rating (max.)	50mA 12V DC
	Rating (min.)	10μA 1V DC
	Insulation resistance	100MΩ min. 100V DC 1min.
	Voltage proof	250V AC 1 min.
Environmental performance	Cold	-40°C 96h
	Dry heat	90°C 96h
	Damp heat	60°C, 90 to 95%RH 1,000h
Automotive		—

Note

● Indicates applicability to all products in the series, while ○ indicates applicability to some products in the series.

TACT Switch™ Radial Type

9.0mm Diameter (Radial) SKRC Series

Round terminal design with excellent mountability, achieving water-proof and dust-proof performance.

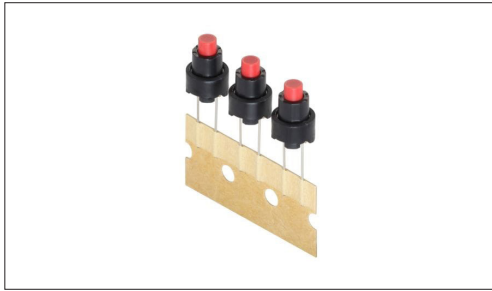

Water-proof Type

Dust-proof Type

- Series type: Sharp feeling type
- Rating (max.): 50mA 12V DC
- Rating (min.): 10μA 1V DC

Applications: Energy_Industrial: Industrial equipment
Home: Major home appliances

■ Product List

Products No.	Operating direction	Operating force (N)	Travel (mm)	Operating life (cycles)	Initial contact resistance	Dimensions (W×D×H) (mm)	Water-proof	Dust-proof	Water-proof & Dust-proof	Automotive	Drawing No.
SKRCACD010	Top push	1.57	0.25	100,000	500mΩ max.	φ9mm×13	●	●	In the coated state	—	1
SKRCADD010	Top push	2.55	0.25	100,000	500mΩ max.	φ9mm×13	●	●	In the coated state	—	

Note

1. This catalog shows only outline specifications. When using the products, please obtain formal specifications for supply.
2. When the switch is used in an environment subject to high humidity or condensation, make sure the terminals are coated thoroughly to prevent current leakage between terminals.
3. Avoid using coating material coating toluene or xylene. For more information on coating material, please contact us.
4. Switch terminals must be coated thoroughly until the terminals are fully covered.
5. For more information on coating material, please contact us.
6. Please use 1.6mm thick PC boards.
7. Please place purchase orders for taping products per minimum order unit (1 box or a case).

■ Packing Specifications

Radial taping

Number of packages (pcs.)			Export package measurements (mm)
1 box	1 case / Japan	1 case / export packing	
900	9,000	9,000	353×764×309

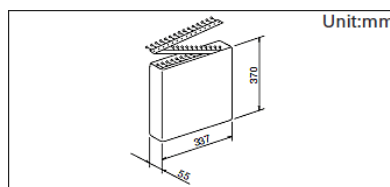

Drawing No.1

■ Dimensions

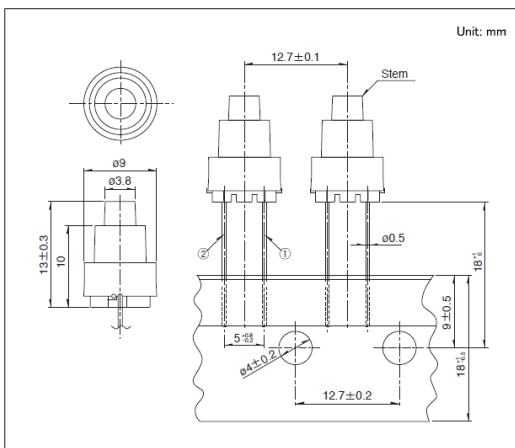

■ Mounting Hole Dimensions

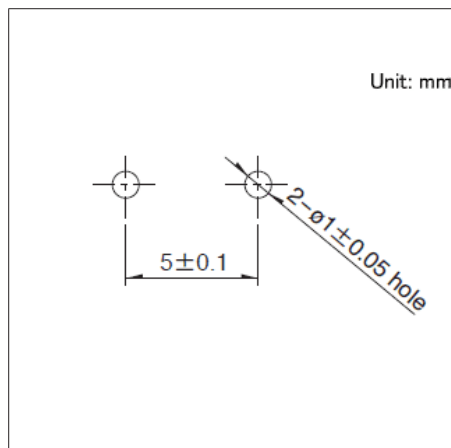

■ Circuit Diagram

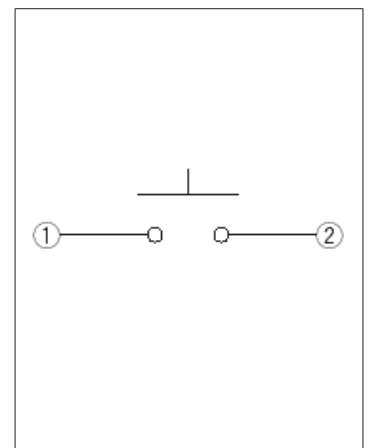

Viewed from mounting face.

TACT Switch™ / Soldering Conditions

■ Condition for Reflow

Available for Surface Mount Type.
Temperature profile

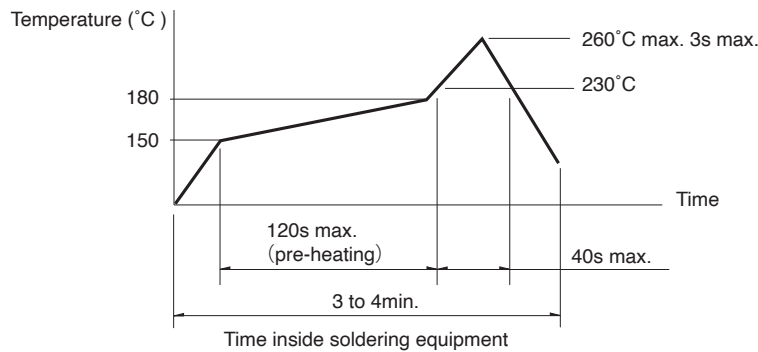

⚠ Note

1. Please confirm the specifications of our product for the detailed condition.
2. Soldering conditions differ depending on reflow soldering machines.
Prior verification of soldering condition is highly recommended.
3. Allowable soldering time : 2 times Max. The second soldering should be done after the switch is stable with normal temperature.

■ Conditions for Auto-dip

Available for Snap-in Type and Radial Type.

Items	Condition
Flux built-up	Mounting surface should not be exposed to flux
Preheating temperature	Ambient temperature of the soldered surface of PC board. 100°C max.
Preheating time	60s max.
Soldering temperature	260°C max.
Duration of immersion	5s max.
Number of soldering	2times max.

SKHH Series

Items	Condition
Flux built-up	Mounting surface should not be exposed to flux
Preheating temperature	Ambient temperature of the soldered surface of PC board. 110°C max.
Preheating time	60s max.
Soldering temperature	260°C max.
Duration of immersion	5s max.
Number of soldering	2times max.

SKHLTop Push Type, SKQJ Series

Items	Condition
Flux built-up	Mounting surface should not be exposed to flux
Preheating temperature	Ambient temperature of the soldered surface of PC board. 100°C max.
Preheating time	45s max.
Soldering temperature	255°C max.
Duration of immersion	5s max.
Number of soldering	2times max.

⚠ Note

1. Prevent flux penetration from the top side of the TACT Switch™.
2. Switch terminals and a PC board should not be coated with flux prior to soldering.
3. The second soldering should be done after the switch is stable with normal temperature.
4. Use the flux with a specific gravity of min 0.81.
(EC-19S-8 by TAMURA CORPORATION, or equivalents.)

■ Manual Soldering

Items

Items	Condition
Soldering temperature	350°Cmax.
Duration of soldering	3s max.
Capacity of soldering iron	60W max.

SKHH, SKHW Series

Items	Condition
Soldering temperature	360°Cmax.
Duration of soldering	3s max.
Capacity of soldering iron	60W max.

SKTD, SKQJ, SKSN Series

Items	Condition
Soldering temperature	350°Cmax.
Duration of soldering	3s max.
Capacity of soldering iron	20W max.

TACT Switch™ / Cautions

1. When terminals are exposed to mechanical stress during soldering, it may cause degradation in deformation and electrical property.
2. Through-hole PC board, or a PC board thickness other than the recommendation may cause larger heat stress. Prior verification is highly recommended.
3. In prior to the 2nd soldering switch shall be stable with normal temperature. It may cause deformation of switch, loose terminals, terminal removed from PC board, and / or degradation of electric property.
4. Verify samples with actual mass production conditions.
5. After soldering, do not wash switches with a solvent, etc.
6. The products are designed and manufactured for direct current resistance. Individual consultation is recommended for use of other resistances such as inductive (L) or capacitive (C).
7. The sizes of holes and patterns on a PC board for mounting a switch, be as per the recommended dimensions in the product drawings.
8. This switch is designed for manually operated units. Must not use this switch for a mechanical detection unit. For detection purposes, please use our detection switch.
9. The switch will be broken if impact force or a greater stress than that specified is applied. Take great care not to let the switch be subject to greater stress than specified.
10. Do not apply a force from the side of the stem.
11. Be sure to push the center of switch for "without-stem" type. Extreme care is required for a hinge structure type, as the activation point may shift when it is pressed down.
12. The circuit setting (software setting) shall be ensured for error-free operations, caused by bounce and chattering as specified by each model of the switches.
13. Prior verification is needed to ensure that no corrosive gas-generating components are used near our switch. It may give negative influence such as contact failure.
14. Contact resistance of a carbon contact type may vary depending on push force. Confirm that it functions sufficiently in using TACT Switch™ with a voltage divider circuit.
15. Be aware of dust intrusion into a non dust-proof TACT switch™.
16. Storage
 1. Store the products as delivered, at a normal temperature and humidity, without direct sunshine and corrosive gas ambient. Use them at an earliest possible timing, not later than six months upon receipt.
 2. After breaking the seal, keep the products in a plastic bag to prevent out ambient air, store them in the same environment as above, and use all as soon as possible.
 3. Do not stack too many switches.
 4. Store the key switches in released position.
17. TACT Switch is a trademark or registered trademark of Alps Alpine Co., Ltd.







Switches

● Detector Switches	129
● Slide Switches	239
● Push Switches	290
● Rotary Switches	320

Switches

Detector Switches







List of Varieties

Series	SPVS	SPVN	SPVT	SPVM	SPVR	SPVE	SSCQ	
Photo								
Features/Type	Horizontal Compact	Horizontal Low-profile	Horizontal	Vertical Compact	Vertical Low-profile lever type	Vertical Compact push operation type	Horizontal Compact	
Operation type	Two-way operation type					One-way operation type	Two-way output, two-step detection type	
Water-proof	—	—	—	—	—	—	—	
Dust-proof	—	—	—	—	—	—	—	
IP standard	—	—	—	—	—	—	—	
Dimensions (mm)	3.3×3.5×1.0	3.6×3.8×1.0	4.7×5.6×1.9	2.8×3.5×1.5	3.6×4.2×1.2	3.4×3.0×2.3 3.4×4.0×1.8	3.8×3.6×0.9	
Poles	1							
Positions	1						Two-direction, 2-positions each side	
Operating force	0.35N max.		0.4N max.		0.35N max.	0.3N max.	0.35N max.	
Operating temperature range	-40°C to +85°C					-10°C to +60°C		
Rating(max.)/(min.) (Resistive load)	1mA 5V DC/50μA 3V DC		50mA 20V DC/ 100μA 3V DC	1mA 5V DC/ 50μA 3V DC	1mA 5V DC/ 100μA 3V DC	0.1A 30V DC/ 50μA 3V DC	1mA 5V DC/ 50μA 3V DC	
Electrical performance	Contact resistance (Initial/After operating life)	2Ω max./5Ω max.		500mΩ max./ 1Ω max.	2Ω max./ 5Ω max.	3Ω max./ 5Ω max.	500mΩ max./ 1Ω max.	2Ω max./ 5Ω max.
	Insulation resistance	100MΩ min. 100V DC						
	Voltage proof	100V AC for 1 minute						
Mechanical performance	Terminal strength	0.5N for 1 minute		1N for 1 minute	0.5N for 1 minute			
	Actuator strength	5N	10N	5N	2N	5N	1N	
Durability	Operating life without load	50,000 cycles 5Ω max.		100,000 cycles 1Ω max.	50,000 cycles 5Ω max.		50,000 cycles 1Ω max.	50,000 cycles 5Ω max.
	Operating life with load Rating(max.) (Resistive load)	50,000 cycles 5Ω max.		100,000 cycles 1Ω max.	50,000 cycles 5Ω max.		50,000 cycles 1Ω max.	50,000 cycles 5Ω max.
Environmental performance	Cold	-40°C 96h				-20°C 96h		
	Dry heat	85°C 96h						
	Damp heat	40°C, 90 to 95%RH 96h						
Automotive	●	●	●	●	●	—	—	

 Note

● Indicates applicability to all products in the series, while ○ indicates applicability to some products in the series.







Detector Switches

Series	SSCM	SPVL	SPPB	SSCT	SSCF	SSCW	SSCL	
Photo								
Features/Type	Horizontal Compact	Horizontal Low-profile	General-purpose type	Micro switch type	Two-way output type	With female connector terminal		
Operation type	Two-way output type	Multi-direction operation type	One-way output type Two-way output type	Two-way output type				
Water-proof	—	—	—	—	—	—	—	
Dust-proof	—	—	—	—	—	—	—	
IP standard	—	—	—	—	—	—	—	
Dimensions (mm)	4.0×5.0×1.5	6.6×5.55×1.0	6.3×3.0×4.9 6.3×5.1×3.7 6.3×6.1×4.25 6.4×3.0×4.9 6.5×3.1×4.9 8.8×3.5×5.1 9.15×3.75×5.5 9.7×3.75×5.1 9.75×3.75×5.7 10.0×6.1×5.25	12.5×5.0×11.5	11.0×5.8×12.4 15.5×5.8×12.4	5.3×13.1×11.35	5.3×11.0×16.1	
Poles	1							
Positions	2	1		2		1	2	
Operating force	0.35N max.			0.7±0.3N	0.7N max.	1N max.	0.7N max.	
Operating temperature range	-10°C to +60°C		-40°C to +85°C					
Rating(max.)/(min.) (Resistive load)	1mA 5V DC/50μA 3V DC		0.1A 30V DC/ 50μA 3V DC	0.1A 12V DC/50μA 3V DC		0.1A 12V DC/ 100μA 3V DC	0.1A 12V DC/ 50μA 5V DC	
Electrical performance	Contact resistance (Initial/After operating life)	2Ω max./5Ω max.		1Ω max./ 2Ω max.	200mΩ max./ 500mΩ max.	100mΩ max./ 300mΩ max.	500mΩ max./1Ω max.	
	Insulation resistance	100MΩ min. 100V DC			100MΩ min. 250V DC	100MΩ min. 100V DC	100MΩ min. 250V DC	100MΩ min. 100V DC
	Voltage proof	100V AC for 1 minute			250V AC for 1 minute	100V AC for 1 minute	250V AC for 1 minute	100V AC for 1 minute
Mechanical performance	Terminal strength	0.5N for 1 minute	1N for 1 minute	3N for 1 minute		5N for 1 minute	—	
	Actuator strength	2N	5N	10N	20N	10N	20N	10N
Durability	Operating life without load	50,000 cycles 5Ω max.		50,000 cycles 2Ω max.	10,000 cycles 500mΩ max.	50,000 cycles 300mΩ max.	100,000 cycles 1Ω max.	50,000 cycles 1Ω max.
	Operating life with load Rating(max.) (Resistive load)	50,000 cycles 5Ω max.		50,000 cycles 2Ω max.	10,000 cycles 500mΩ max.	50,000 cycles 300mΩ max.	100,000 cycles 1Ω max.	50,000 cycles 1Ω max.
Environmental performance	Cold	-20°C 96h	-40°C 500h					
	Dry heat	85°C 96h	85°C 500h					
	Damp heat	40°C, 90 to 95%RH 96h	60°C, 90 to 95%RH 500h					
Automotive	—	●	●	●	●	●	●	

⚠ Note

● Indicates applicability to all products in the series, while ○ indicates applicability to some products in the series.





Detector Switches

Series	SSCZ	SPVQ3	SPVQ6	SPVQ7	SPVQ8	SPVQ8H	SPVQ9	
Photo								
Features/Type	Connector terminal 1-pole 2-positions type	Water-proof type Long travel type	Compact size & water-proof type With internal resistor type	Water-proof type	Ultra-compact & water-proof type With internal resistor type	Water-proof type	Water-proof type Two-pole fast switching type	
Operation type	Two-way output type		One-way output type Two-way output type	Two-way output type				
Water-proof	—	●	●	●	●	●	●	
Dust-proof	—	●	●	●	●	●	●	
IP standard	—	IP6K7	IP6K7	IP6K7	IP6K7	IP6K7	IP6K7	
Dimensions (mm)	13.84×5.4×15.4	5.3×13.0×8.35	5.3×13.3×6.5	5.4×14.7×6.7	5.3×8.3×6.5	6.45×14.8×14.5 6.45×17.95×14.5	8.4×15.4×7.5	
Poles	1						2	
Positions	2	1 2			1		2	
Operating force	1.1N max.	1±0.5N 3N max.		1±0.5N	1±0.5N 3N max.	4.7N max.	1±0.5N	
Operating temperature range	-40°C to +85°C							
Rating(max.)/(min.) (Resistive load)	0.1A 16V DC/ 100μA 3V DC	0.1A 12V DC/ 50μA 5V DC	0.1A 12V DC/ 50μA 5V DC Respond individually	0.1A 12V DC/ 50μA 5V DC	0.1A 16V DC/ 50μA 5V DC Respond individually	0.1A 16V DC/ 50μA 5V DC	50mA 26V DC/ 50μA 5V DC	
Electrical performance	Contact resistance (Initial/After operating life)	500mΩ max./1Ω max.		500mΩ max./1Ω max. Respond individually	500mΩ max./ 1Ω max.	500mΩ max./1Ω max. 500mΩ max./3Ω max. Respond individually	500mΩ max./ 1Ω max.	75mΩ max./ 200mΩ max.
	Insulation resistance	100MΩ min. 250V DC	100MΩ min. 500V DC	100MΩ min. 500V DC Respond individually	100MΩ min. 500V DC	100MΩ min. 500V DC Respond individually	100MΩ min. 500V DC	
	Voltage proof	250V AC for 1minute	500V AC for 1 minute	500V AC for 1 minute Respond individually	500V AC for 1 minute	500V AC for 1 minute Respond individually	500V AC for 1 minute	
Mechanical performance	Terminal strength	—	3N for 1 minute				110N for 1 minute	3N for 1 minute
	Actuator strength	20N						
Durability	Operating life without load	300,000 cycles 1Ω max.		300,000 cycles 300,000 cycles 1Ω max.	300,000 cycles 1Ω max.	300,000 cycles 300,000 cycles 1Ω max. 1,000,000 cycles 3Ω max.	100,000cycles 1Ω max.	300,000 cycles 200mΩ max.
	Operating life with load Rating(max.) (Resistive load)	300,000 cycles 1Ω max.		300,000 cycles 1Ω max. Respond individually	300,000 cycles 1Ω max.	300,000 cycles 1Ω max. 1,000,000 cycles 3Ω max. Respond individually	100,000cycles 1Ω max.	300,000 cycles 200mΩ max.
Environmental performance	Cold	-40°C 500h						
	Dry heat	85°C 500h						
	Damp heat	60°C, 90 to 95%RH 500h						
Automotive	●	●	●	●	●	●	●	

 Note

● Indicates applicability to all products in the series, while ○ indicates applicability to some products in the series.

Detector Switches

Series		SPVQA	SPVQC	SPVQF	SSCN	SDDH
Photo						
Features/Type		Water-proof type (Fork terminals)	Water-proof type Two-pole fast switching type (surface mount)		Water-proof type	
Operation type		Two-way output type				Push
Water-proof		●	●	●	●	●
Dust-proof		●	●	●	●	●
IP standard		IP6K7	IP6K7	IP6K7	IP6K7	IP6K8
Dimensions (mm)		6.4×15.2×7.95	7.4×15.4×7.5	6.3×8.5×7.0	5.0×13.0×15.0	28.5×9.0×24.3
Poles		1	2		1	
Positions		1 2	2			1
Operating force		1±0.5N		1.8N max.	2N max.	4.6N max.
Operating temperature range		-40°C to +85°C		-40°C to +90°C	-40°C to +85°C	-15°C to +80°C
Rating(max.)/(min.) (Resistive load)		0.1A 12V DC/ 50μA 5V DC	50mA 18V DC/50μA 5V DC		0.1A 12V DC/ 100μA 5V DC	4.5A 12V DC/ 10mA 12V DC
Electrical performance	Contact resistance (Initial/After operating life)	500mΩ max./ 1Ω max.	75mΩ max./ 200mΩ max.	75mΩ max./ 2Ω max.	500mΩ max./1Ω max.	
	Insulation resistance	100MΩ min. 500V DC	100MΩ min. 250V DC		100MΩ min. 500V DC	10MΩ min. 500V DC
	Voltage proof	500V AC for 1 minute	250V AC for 1 minute		500V AC for 1 minute	
Mechanical performance	Terminal strength	3N for 1 minute		5±1N for 10±1S	3N for 1 minute	Slider pull-out strength: 100N min
	Actuator strength	20N			10N	—
Durability	Operating life without load	300,000 cycles 1Ω max.	300,000 cycles 200mΩ max.	300,000 cycles 2Ω max.	100,000 cycles 1Ω max.	
	Operating life with load Rating(max.) (Resistive load)	300,000 cycles 1Ω max.	300,000 cycles 200mΩ max.	300,000 cycles 2Ω max.	100,000 cycles 1Ω max.	
Environmental performance	Cold	-40°C 500h				-15°C 96h
	Dry heat	85°C 500h		90°C 500h	85°C 500h	80°C 96h
	Damp heat	60°C, 90 to 95%RH 500h				40°C, 90 to 95%RH 96h
Automotive		●	●	●	●	●

⚠ Note

● Indicates applicability to all products in the series, while ○ indicates applicability to some products in the series.

Compact Two-way Operation SPVS Series

Compact, thin-profile type with a body height of 1.0mm, 3.3×3.5mm, offering N/O & N/C two-circuit varieties.

 Automotive

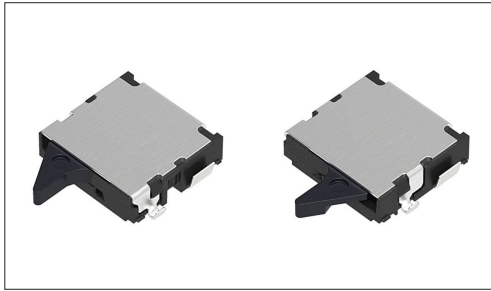

- Rating(max.)/(min.)(Resistive load): 1mA 5V DC/50 μ A 3V DC
- Contact resistance(Initial/After operating life): 2 Ω max./5 Ω max.
- Operating life without load: 50,000 cycles
- Operating life with load Rating(max.)(Resistive load):
50,000 cycles 5 Ω max.

Applications: Mobile: Smartphones, tablets, Headsets, wearables,
Notebooks, peripherals
Energy_Industrial: Robots, drones, Industrial equipment,
Converters
Game: Home handheld consoles, Virtual/augmented reality
Healthcare: Healthcare equipment, Nursing care
equipment, Analysis, test equipment
Audio_TV: Visual, Audio, Cameras
Automotive: Navigation/audio systems, HVAC

Product List

Products No.	Poles	Positions	Operating force	Terminal type	Lever length	Operating direction	Circuit	Location lug	Dimensions (W×D×H) (mm)	Water-proof	Dust-proof	Automotive	Drawing No.
SPVS310100	1	1	0.35N max.	For PC board (Reflow)	Standard	Right	N/O	With	3.3×3.5×1.0	—	—	●	1
SPVS310200	1	1	0.35N max.	For PC board (Reflow)	Standard	Right	N/O	Without	3.3×3.5×1.0	—	—	●	2
SPVS320100	1	1	0.35N max.	For PC board (Reflow)	Standard	Right	N/C	With	3.3×3.5×1.0	—	—	●	3
SPVS320200	1	1	0.35N max.	For PC board (Reflow)	Standard	Right	N/C	Without	3.3×3.5×1.0	—	—	●	4
SPVS410100	1	1	0.35N max.	For PC board (Reflow)	Standard	Left	N/O	With	3.3×3.5×1.0	—	—	●	5
SPVS410200	1	1	0.35N max.	For PC board (Reflow)	Standard	Left	N/O	Without	3.3×3.5×1.0	—	—	●	6
SPVS420100	1	1	0.35N max.	For PC board (Reflow)	Standard	Left	N/C	With	3.3×3.5×1.0	—	—	●	7
SPVS420200	1	1	0.35N max.	For PC board (Reflow)	Standard	Left	N/C	Without	3.3×3.5×1.0	—	—	●	8
SPVS360100	1	1	0.35N max.	For PC board (Reflow)	Long	Right	N/C	With	3.3×3.5×1.0	—	—	●	9
SPVS360200	1	1	0.35N max.	For PC board (Reflow)	Long	Right	N/C	Without	3.3×3.5×1.0	—	—	●	10

Note

1. This catalog shows only outline specifications. When using the products, please obtain formal specifications for supply.
2. Please place purchase orders per minimum order unit (integer).
3. This products can be used in vehicles.
Although these products are designed to perform over a wide operating temperature range, please ensure that you receive and read the formal delivery specifications before use.
4. For the Terminal Layout, please check our website.

Compact Two-way Operation
SPVS Series

■ Packing Specifications

Taping

Number of packages (pcs.)			Tape width (mm)	Export package measurements (mm)
1 reel	1 case / Japan	1 case / export packing		
5,000	10,000	20,000	16	417 x 409 x 139

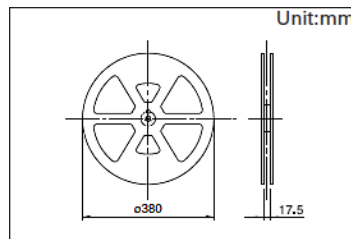

Drawing No.1

■ Dimensions

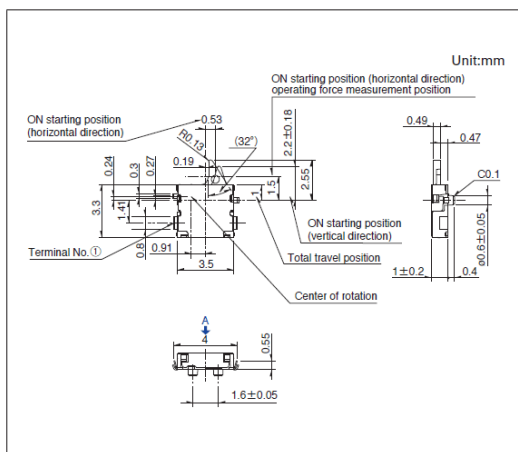

■ Land Dimensions

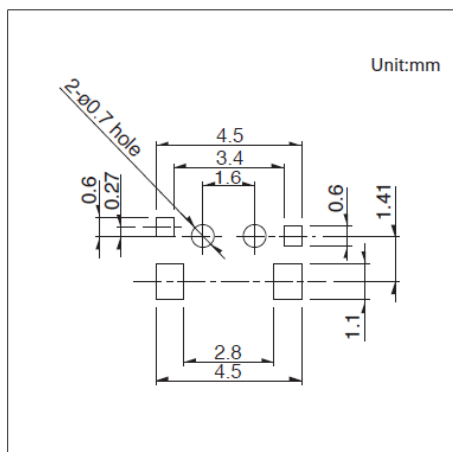

■ Circuit Diagram

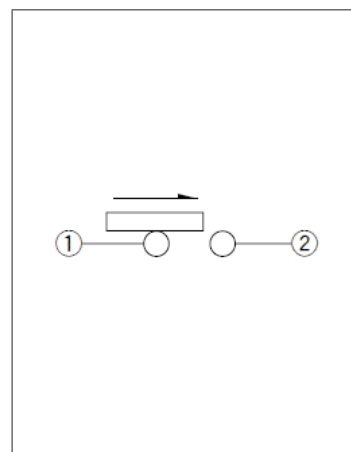

Viewed from direction A in the dimensions.

Drawing No.2

■ Dimensions

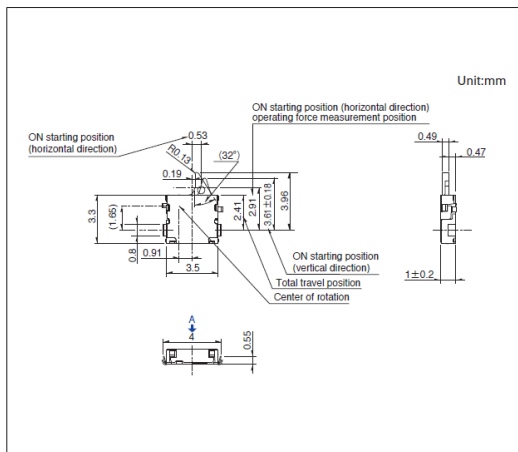

■ Land Dimensions

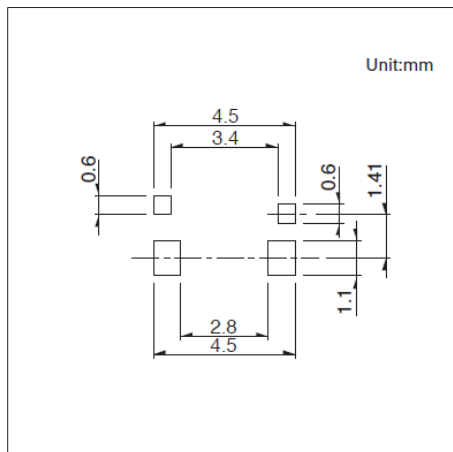

■ Circuit Diagram

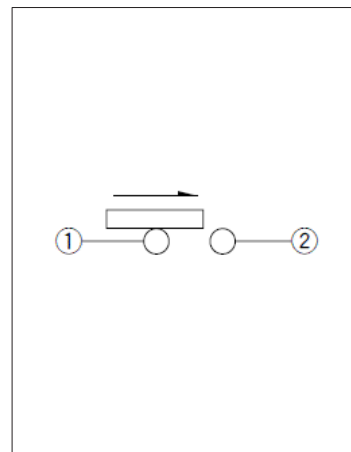

Viewed from direction A in the dimensions.

Compact Two-way Operation
SPVS Series

Drawing No.3

■ Dimensions

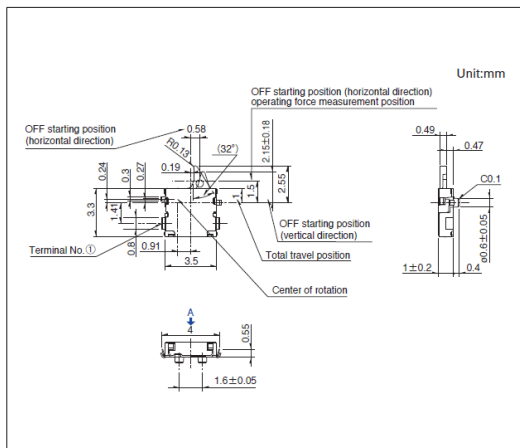

■ Land Dimensions

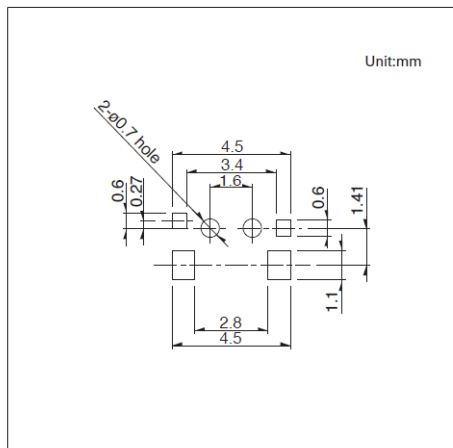

■ Circuit Diagram

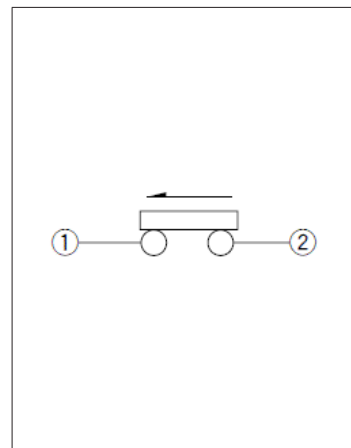

Viewed from direction A in the dimensions.

Drawing No.4

■ Dimensions

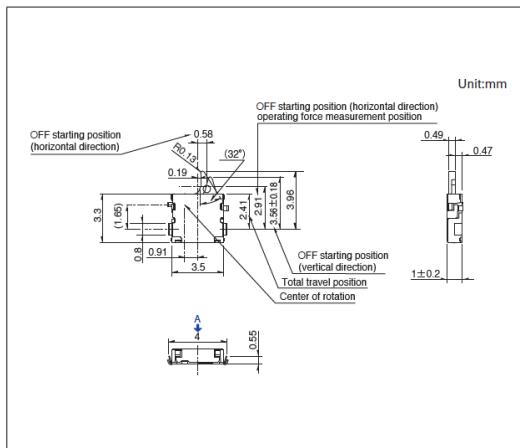

■ Land Dimensions

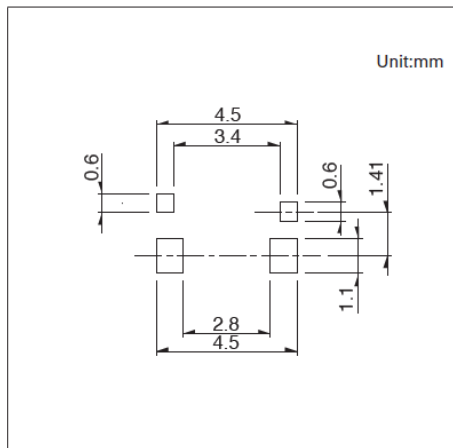

■ Circuit Diagram

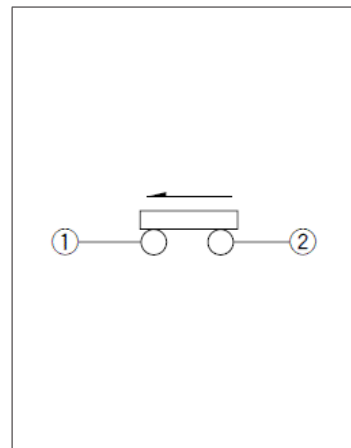

Viewed from direction A in the dimensions.

Drawing No.5

■ Dimensions

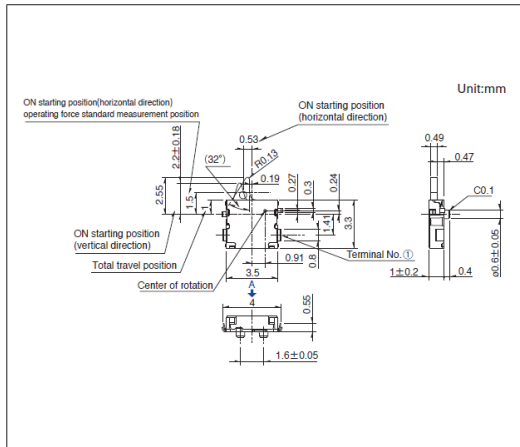

■ Land Dimensions

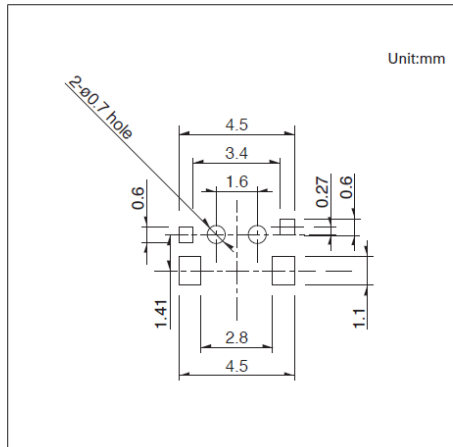

■ Circuit Diagram

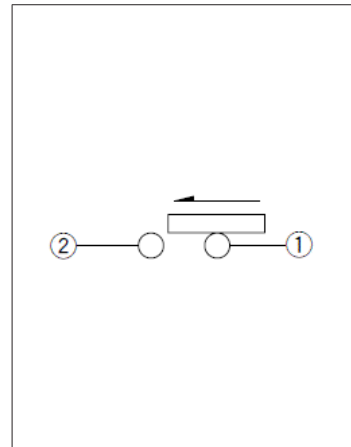

Viewed from direction A in the dimensions.

Compact Two-way Operation
SPVS Series

Drawing No.6

■ Dimensions

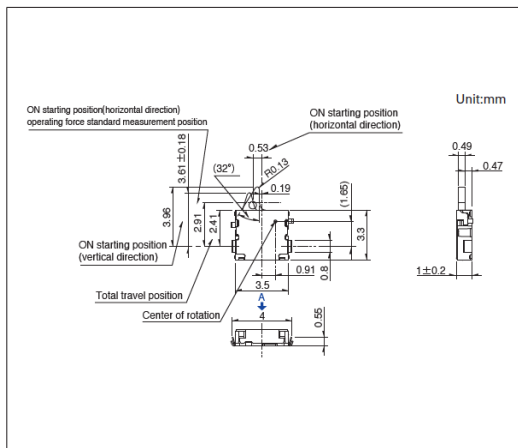

■ Land Dimensions

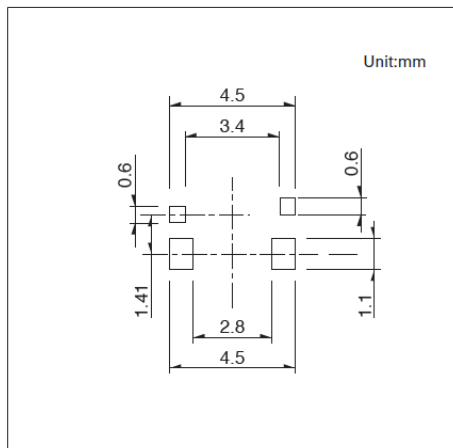

■ Circuit Diagram

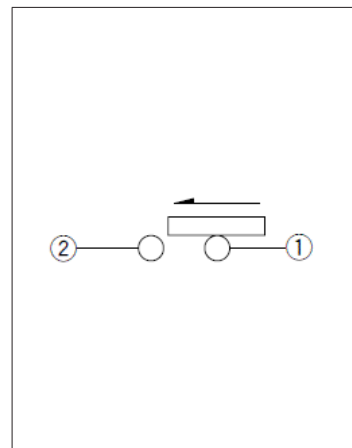

Viewed from direction A in the dimensions.

Drawing No.7

■ Dimensions

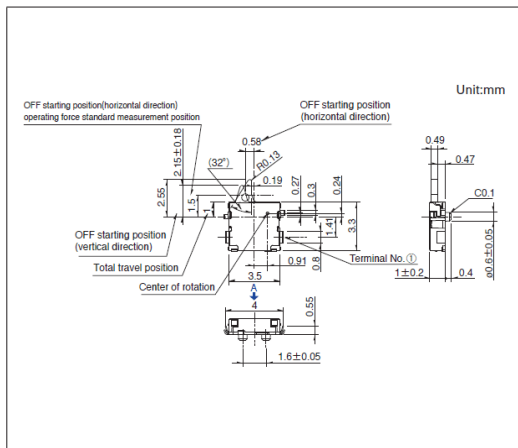

■ Land Dimensions

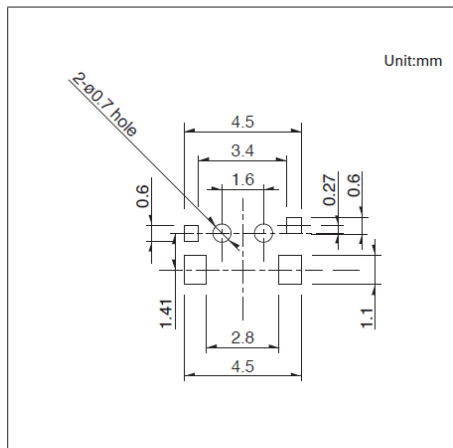

■ Circuit Diagram

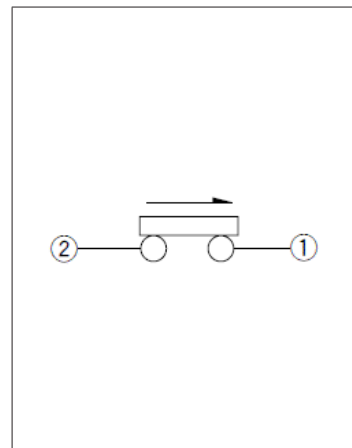

Viewed from direction A in the dimensions.

Drawing No.8

■ Dimensions

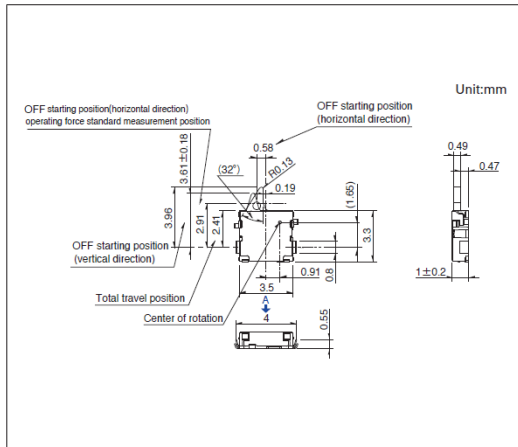

■ Land Dimensions

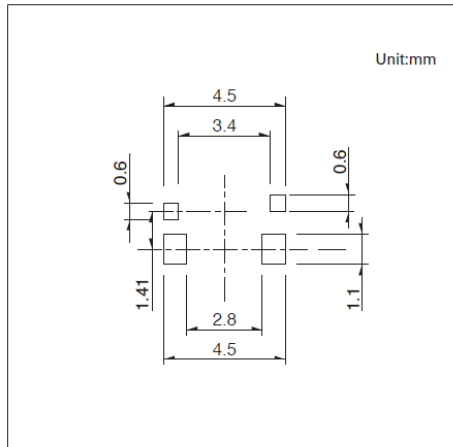

■ Circuit Diagram

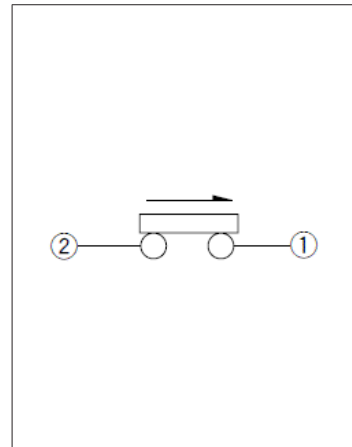

Viewed from direction A in the dimensions.

Compact Two-way Operation
SPVS Series

Drawing No.9

■ Dimensions

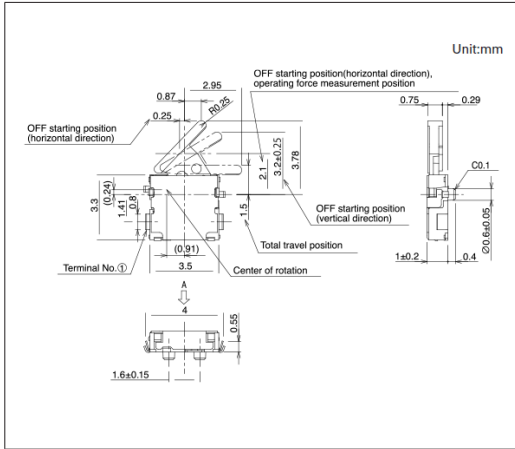

■ Land Dimensions

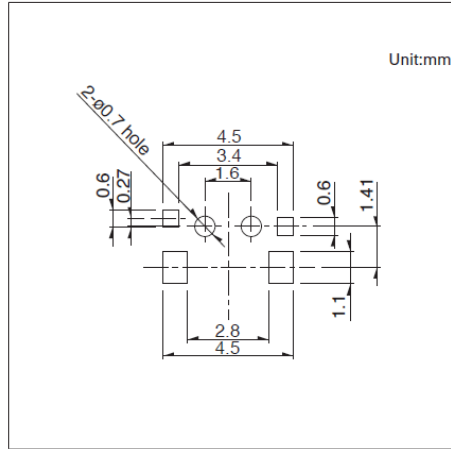

■ Circuit Diagram

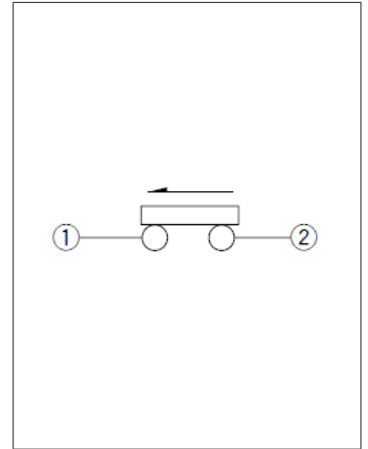

Viewed from direction A in the dimensions.

Drawing No.10

■ Dimensions

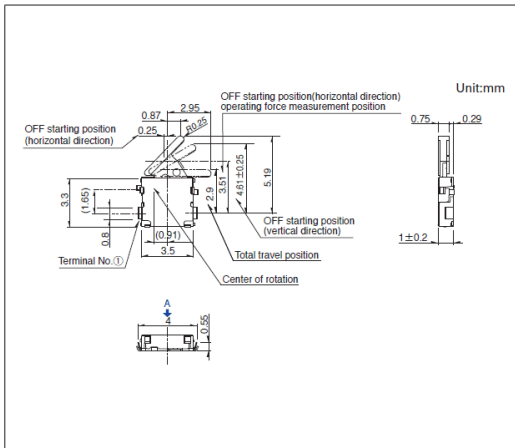

■ Land Dimensions

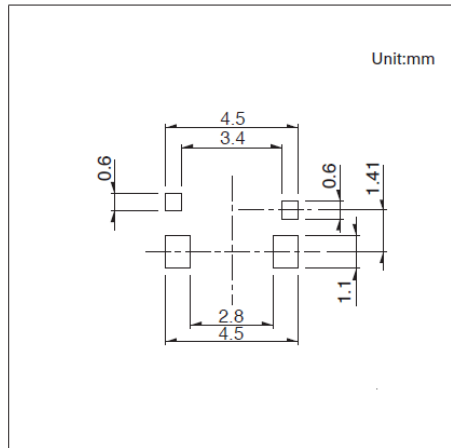

■ Circuit Diagram

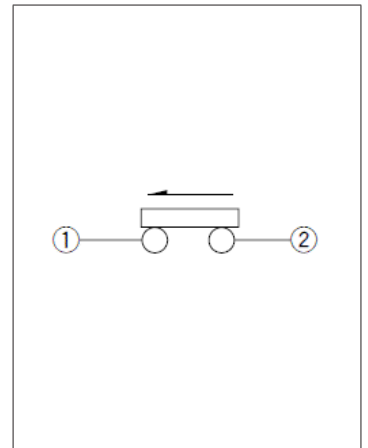

Viewed from direction A in the dimensions.

Low-profile Two-way Operation SPVN Series

Thin-profile type with a body height of 1.0mm, 3.6×3.8mm.



 Automotive

- Rating(max.)/(min.)(Resistive load): 1mA 5V DC/50 μ A 3V DC
- Contact resistance(Initial/After operating life): 2 Ω max./5 Ω max.
- Operating life without load: 50,000 cycles
- Operating life with load Rating(max.)(Resistive load):
50,000 cycles 5 Ω max.

Applications: Mobile: Smartphones, tablets, Headsets, wearables,
Notebooks, peripherals
Healthcare: Healthcare equipment
Audio_TV: Visual, Audio, Cameras
Automotive: Navigation/audio systems, HVAC

Product List

Products No.	Poles	Positions	Operating force	Terminal type	Lever length	Operating direction	Location lug	Dimensions (W×D×H) (mm)	Water-proof	Dust-proof	Automotive	Drawing No.
SPVN110107	1	1	0.35N max.	For PC board (Reflow)	Standard	Right	With	3.6×3.8×1.0	—	—	●	1
SPVN120104	1	1	0.35N max.	For PC board (Reflow)	Standard	Right	Without	3.6×3.8×1.0	—	—	●	2
SPVN210106	1	1	0.35N max.	For PC board (Reflow)	Standard	Left	With	3.6×3.8×1.0	—	—	●	3
SPVN220103	1	1	0.35N max.	For PC board (Reflow)	Standard	Left	Without	3.6×3.8×1.0	—	—	●	4
SPVN310101	1	1	0.35N max.	For PC board (Reflow)	Long	Right	With	3.6×3.8×1.0	—	—	●	5
SPVN320101	1	1	0.35N max.	For PC board (Reflow)	Long	Right	Without	3.6×3.8×1.0	—	—	●	6
SPVN410101	1	1	0.35N max.	For PC board (Reflow)	Long	Left	With	3.6×3.8×1.0	—	—	●	7
SPVN420101	1	1	0.35N max.	For PC board (Reflow)	Long	Left	Without	3.6×3.8×1.0	—	—	●	8

Note

1. This catalog shows only outline specifications. When using the products, please obtain formal specifications for supply.
2. Please place purchase orders per minimum order unit (integer).
3. This products can be used in vehicles.
Although these products are designed to perform over a wide operating temperature range, please ensure that you receive and read the formal delivery specifications before use.
4. For the Terminal Layout, please check our website.

Packing Specifications

Taping

Number of packages (pcs.)			Tape width (mm)	Export package measurements (mm)
1 reel	1 case / Japan	1 case / export packing		
5,000	10,000	20,000	16	417 x 409 x 139

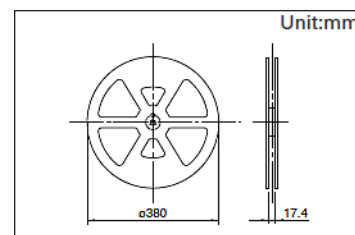

Drawing No.1

■ Dimensions

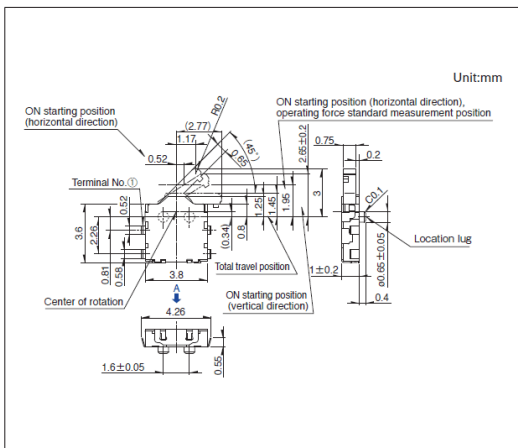

■ Land Dimensions

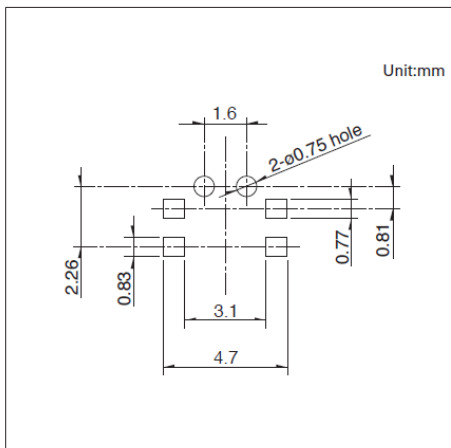

■ Circuit Diagram

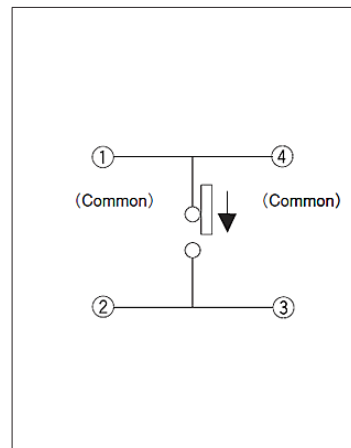

Viewed from direction A in the dimensions.

Drawing No.2

■ Dimensions

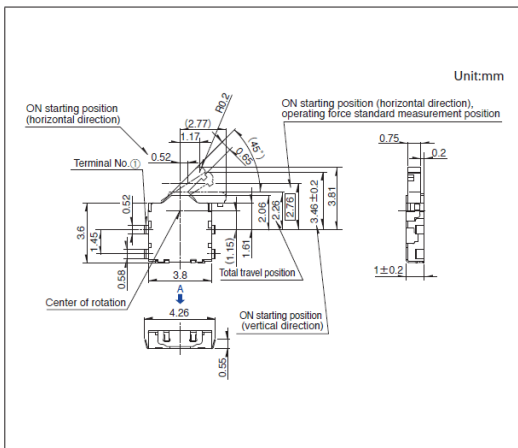

■ Land Dimensions

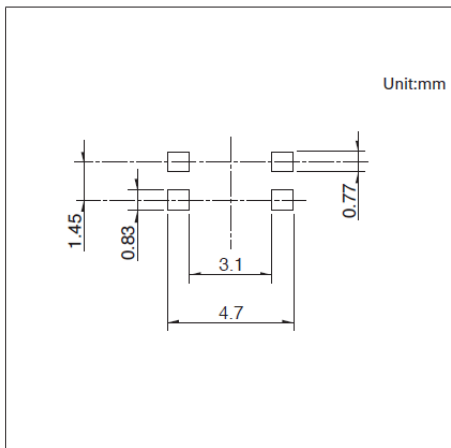

■ Circuit Diagram

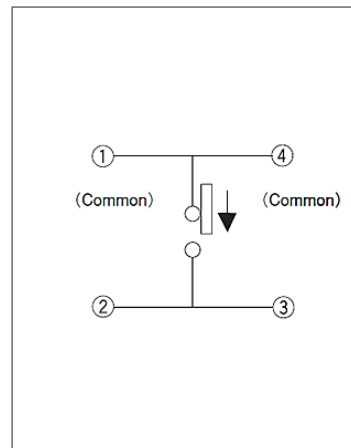

Viewed from direction A in the dimensions.

Drawing No.3

■ Dimensions

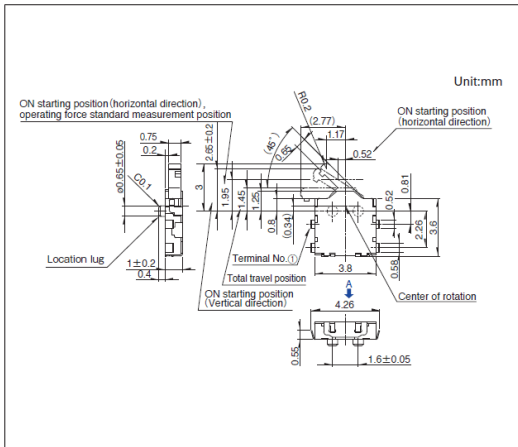

■ Land Dimensions

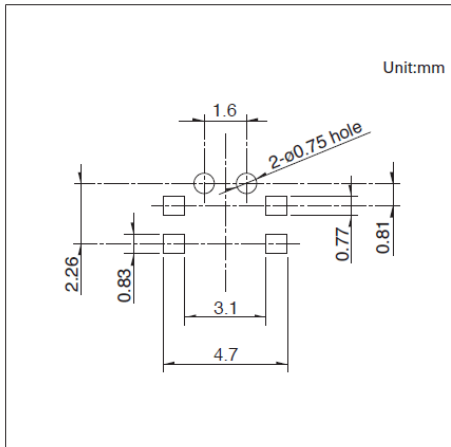

■ Circuit Diagram

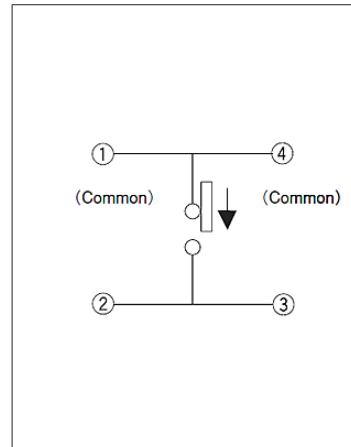

Viewed from direction A in the dimensions.

Low-profile Two-way Operation
SPVN Series

Drawing No.4

■ Dimensions

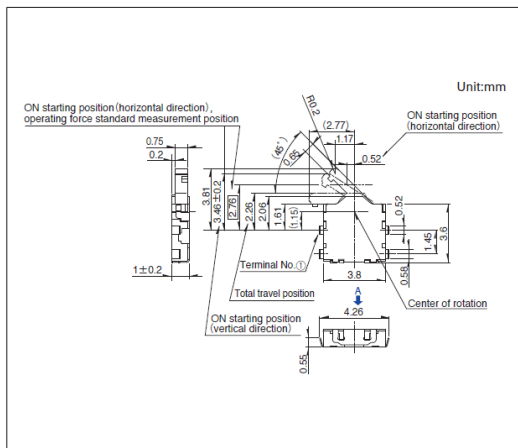

■ Land Dimensions

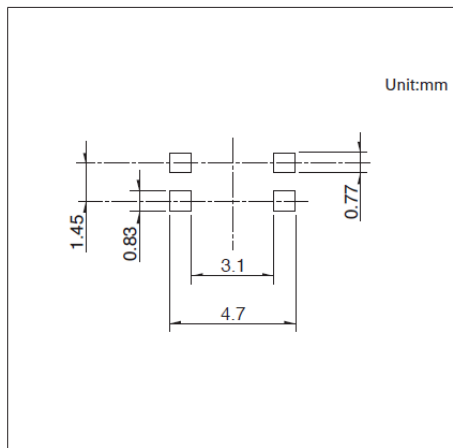

■ Circuit Diagram

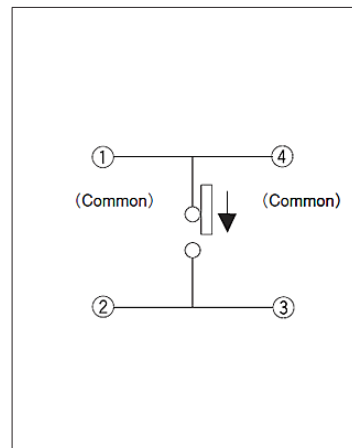

Viewed from direction A in the dimensions.

Drawing No.5

■ Dimensions

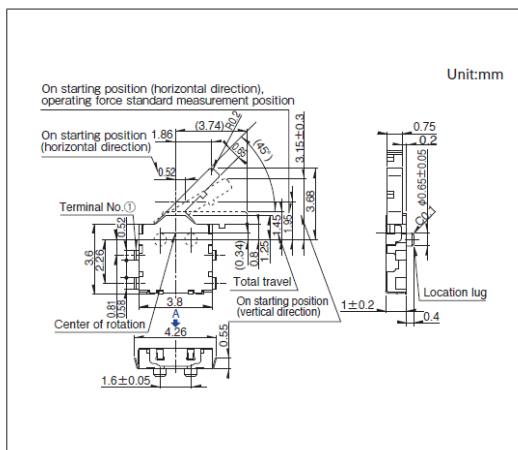

■ Land Dimensions

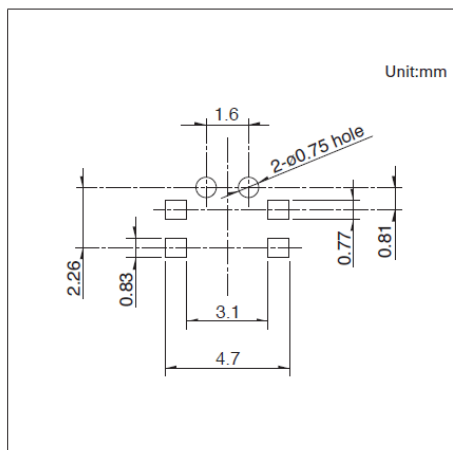

■ Circuit Diagram

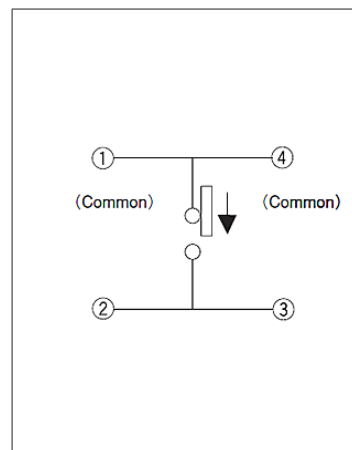

Viewed from direction A in the dimensions.

Drawing No.6

■ Dimensions

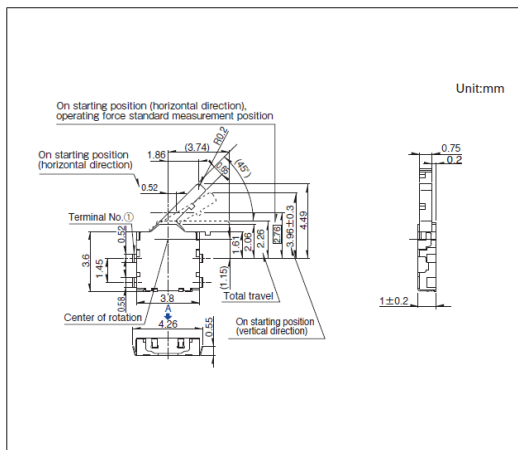

■ Land Dimensions

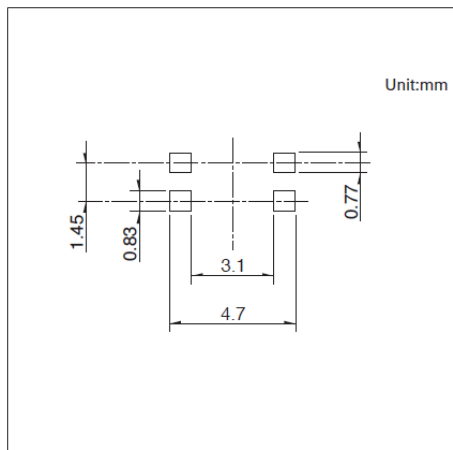

■ Circuit Diagram

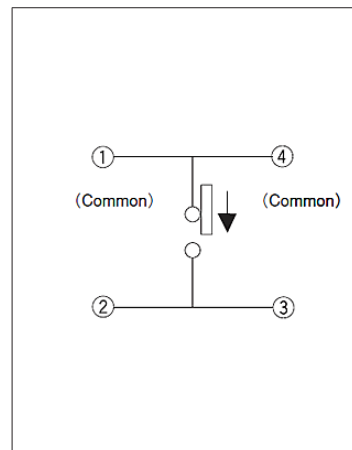

Viewed from direction A in the dimensions.

Low-profile Two-way Operation
SPVN Series

Drawing No.7

■ Dimensions

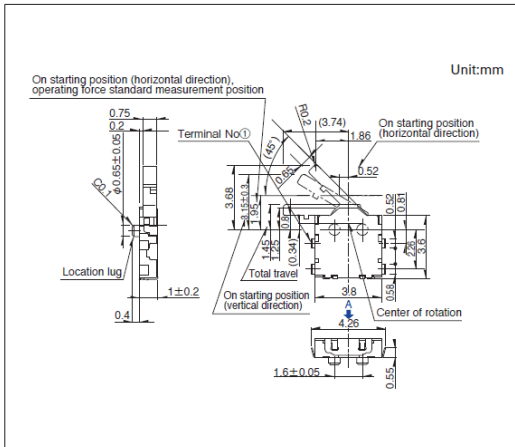

■ Land Dimensions

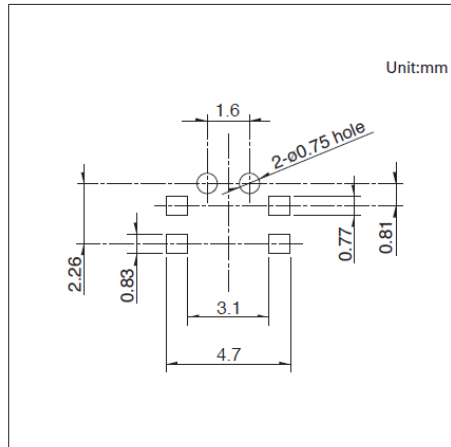

■ Circuit Diagram

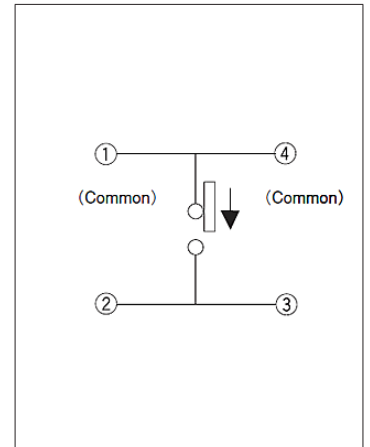

Viewed from direction A in the dimensions.

Drawing No.8

■ Dimensions

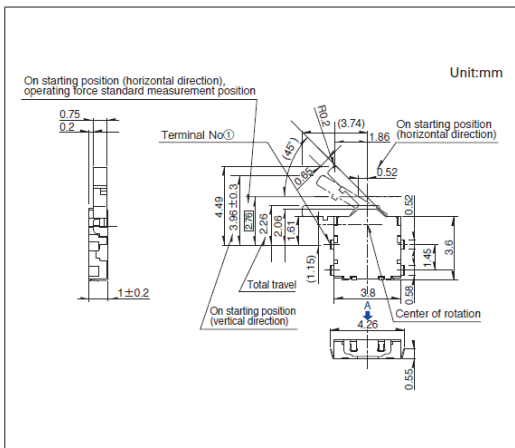

■ Land Dimensions

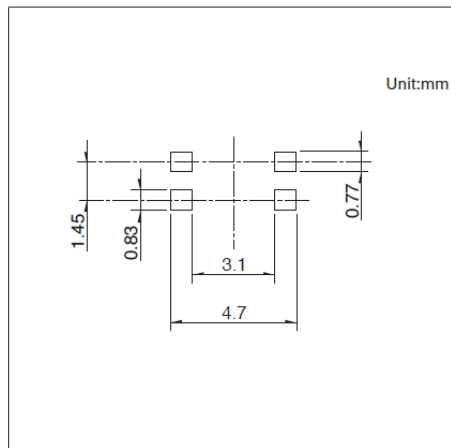

■ Circuit Diagram

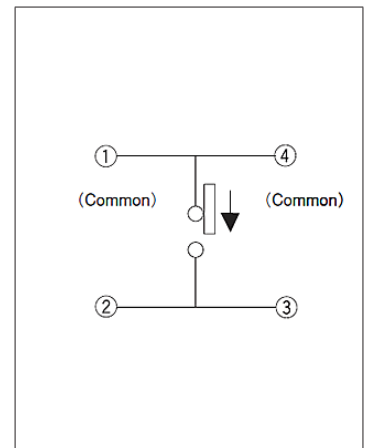

Viewed from direction A in the dimensions.

Two-way Operation

SPVT Series

Compact type with a body height of 1.9mm, 4.7×5.6mm, capable of two-direction detection.

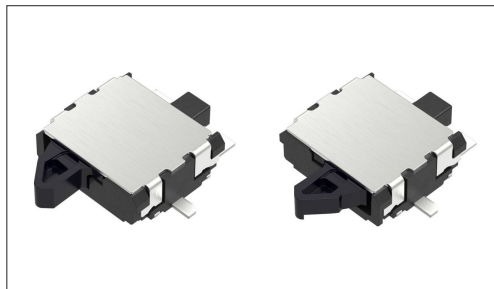
 Automotive

- Rating(max.)/(min.)(Resistive load):50mA 20V DC/100μA 3V DC
- Contact resistance(Initial/After operating life):500mΩ max./1Ω max.
- Operating life without load:100,000 cycles
- Operating life with load Rating(max.)(Resistive load):
100,000 cycles 1Ω max.

Applications: Mobile: Smartphones, tablets, Notebooks, peripherals
 Energy_Industrial: Robots, drones, Industrial equipment, Converters
 Game: Home handheld consoles, Virtual/augmented reality
 Healthcare: Healthcare equipment, Nursing care equipment, Analysis, test equipment
 Infrastructure: Smart meters, Power distribution facilities, Data servers, Communications cables
 Home: Major home appliances, Distribution boards, Storage batteries, Office equipment
 Audio_TV: Visual, Audio, Pro audio, Cameras
 Automotive: Navigation/audio systems, HVAC

■ Product List

Products No.	Poles	Positions	Operating force	Terminal type	Operating direction	Location lug	Dimensions (W×D×H) (mm)	Water-proof	Dust-proof	Automotive	Drawing No.
SPVT110106	1	1	0.4N max.	For PC board (Reflow)	Right	With	4.7×5.6×1.9	—	—	●	1
SPVT130102	1	1	0.4N max.	For PC board (Reflow)	Right	With	4.7×5.6×1.9	—	—	●	2
SPVT120103	1	1	0.4N max.	For PC board (Reflow)	Right	With	4.7×5.6×1.9	—	—	●	3
SPVT140104	1	1	0.4N max.	For PC board (Reflow)	Right	With	4.7×5.6×1.9	—	—	●	4
SPVT110202	1	1	0.4N max.	For PC board (Reflow)	Right	Without	4.7×5.6×1.9	—	—	●	5
SPVT130202	1	1	0.4N max.	For PC board (Reflow)	Right	Without	4.7×5.6×1.9	—	—	●	6
SPVT120202	1	1	0.4N max.	For PC board (Reflow)	Right	Without	4.7×5.6×1.9	—	—	●	7
SPVT210104	1	1	0.4N max.	For PC board (Reflow)	Left	With	4.7×5.6×1.9	—	—	●	8
SPVT230103	1	1	0.4N max.	For PC board (Reflow)	Left	With	4.7×5.6×1.9	—	—	●	9
SPVT220103	1	1	0.4N max.	For PC board (Reflow)	Left	With	4.7×5.6×1.9	—	—	●	10
SPVT240103	1	1	0.4N max.	For PC board (Reflow)	Left	With	4.7×5.6×1.9	—	—	●	11
SPVT210202	1	1	0.4N max.	For PC board (Reflow)	Left	Without	4.7×5.6×1.9	—	—	●	12
SPVT230202	1	1	0.4N max.	For PC board (Reflow)	Left	Without	4.7×5.6×1.9	—	—	●	13
SPVT220202	1	1	0.4N max.	For PC board (Reflow)	Left	Without	4.7×5.6×1.9	—	—	●	14

 Note

1. This catalog shows only outline specifications. When using the products, please obtain formal specifications for supply.
2. Please place purchase orders for taping products per minimum order unit (1 reel or a case).
3. This products can be used in vehicles.
Although these products are designed to perform over a wide operating temperature range, please ensure that you receive and read the formal delivery specifications before use.
4. For the Terminal Layout, please check our website.

Two-way Operation
SPVT Series

■ Packing Specifications

Taping

Number of packages (pcs.)			Tape width (mm)	Export package measurements (mm)
1 reel	1 case / Japan	1 case / export packing		
2,500	5,000	10,000	16	417 x 409 x 139

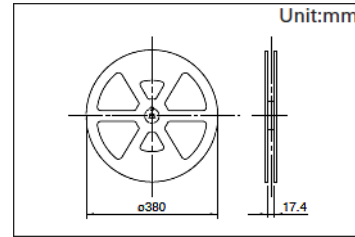

Drawing No.1

■ Dimensions

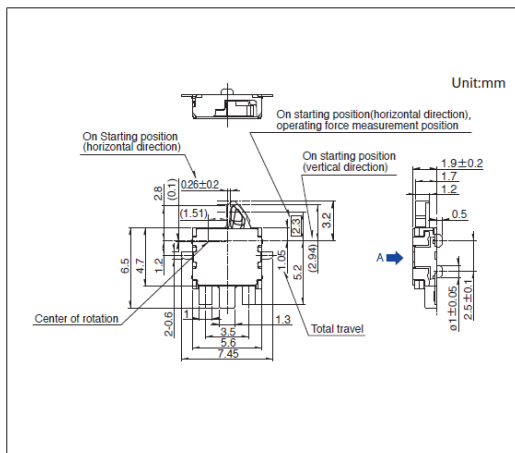

■ Land Dimensions

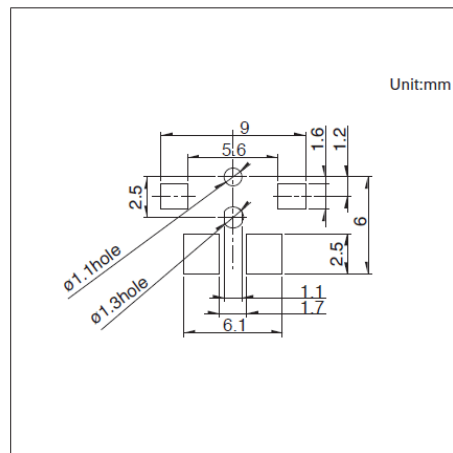

■ Circuit Diagram

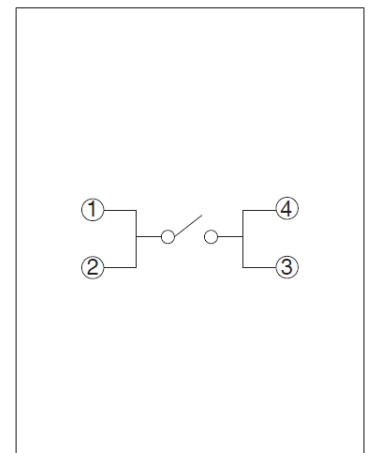

Viewed from direction A in the dimensions.

Drawing No.2

■ Dimensions

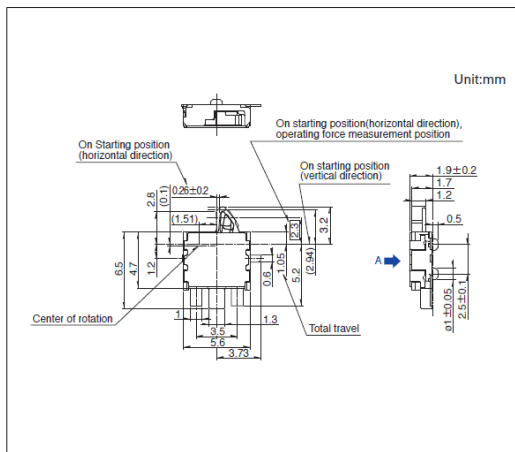

■ Land Dimensions

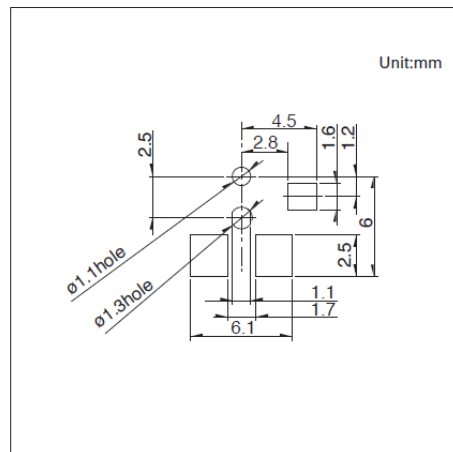

■ Circuit Diagram

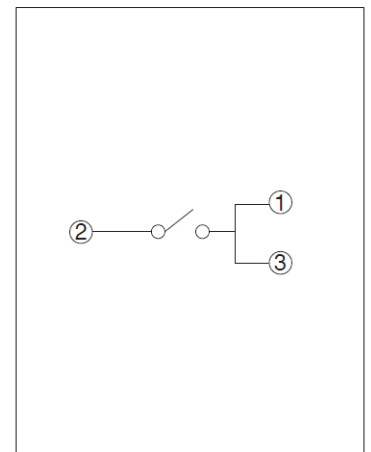

Viewed from direction A in the dimensions.

Two-way Operation
SPVT Series

Drawing No.3

■ Dimensions

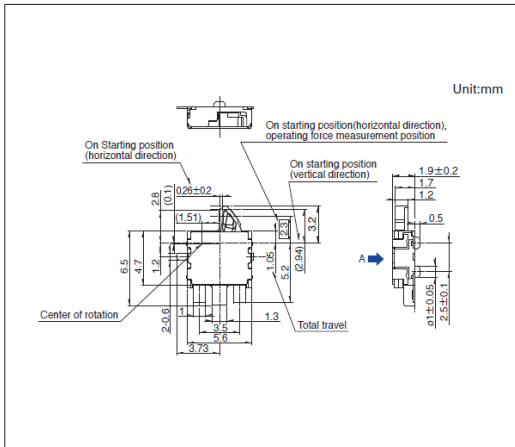

■ Land Dimensions

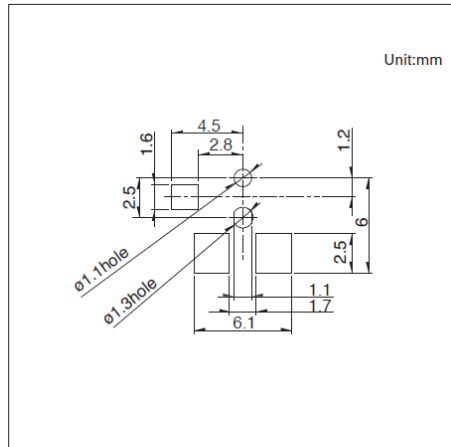

■ Circuit Diagram

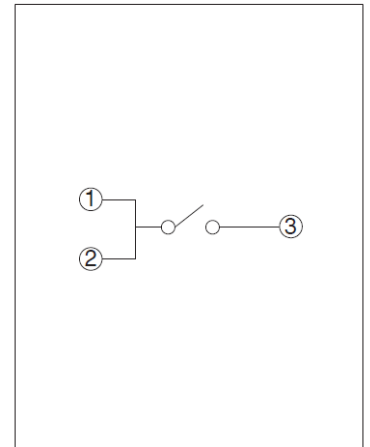

Viewed from direction A in the dimensions.

Drawing No.4

■ Dimensions

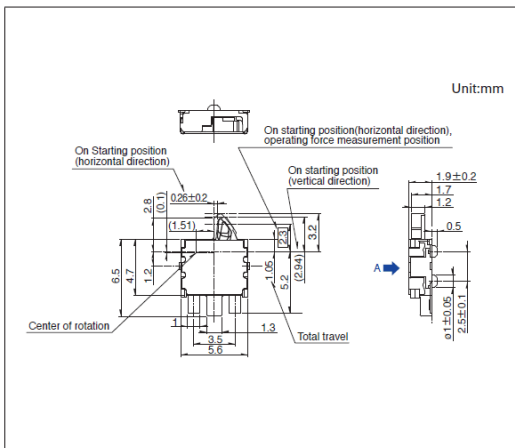

■ Land Dimensions

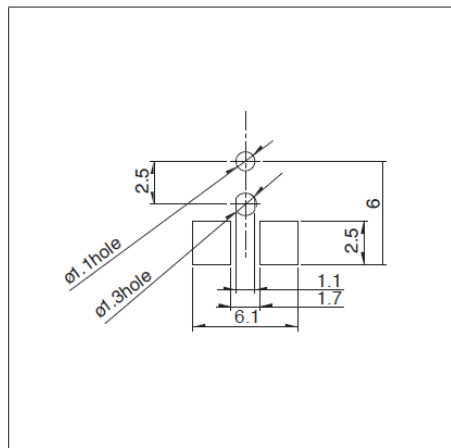

■ Circuit Diagram

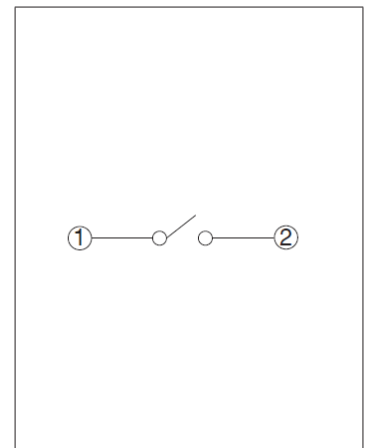

Viewed from direction A in the dimensions.

Drawing No.5

■ Dimensions

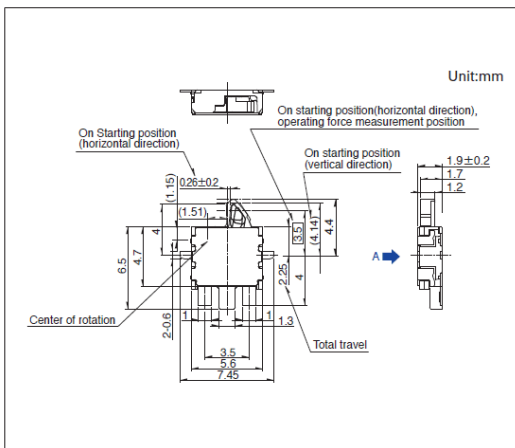

■ Land Dimensions

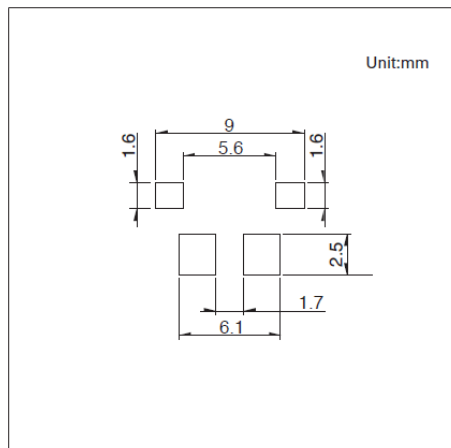

■ Circuit Diagram

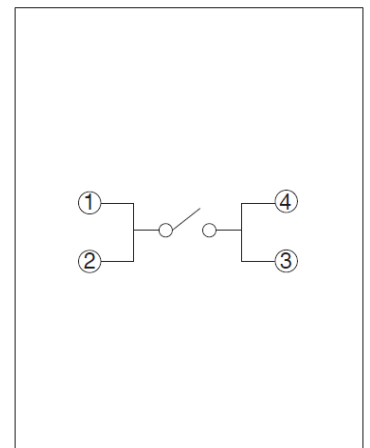

Viewed from direction A in the dimensions.

Two-way Operation
SPVT Series

Drawing No.6

■ Dimensions

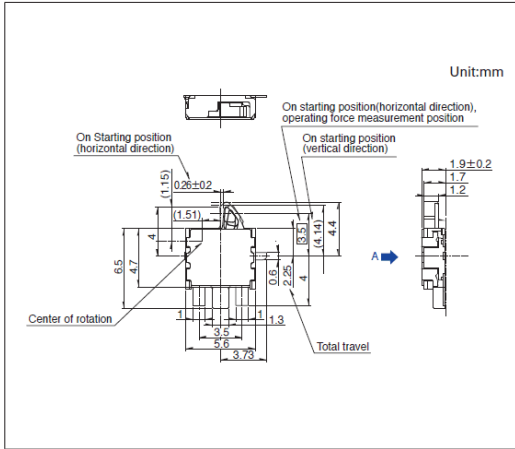

■ Land Dimensions

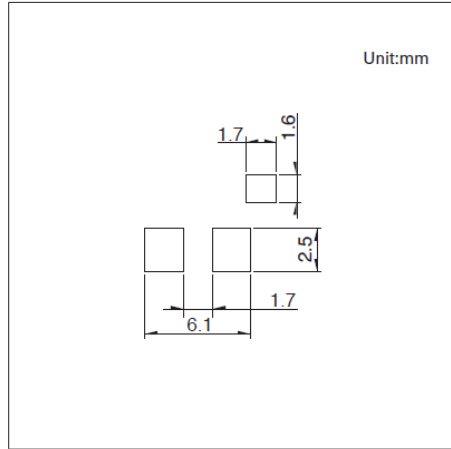

■ Circuit Diagram

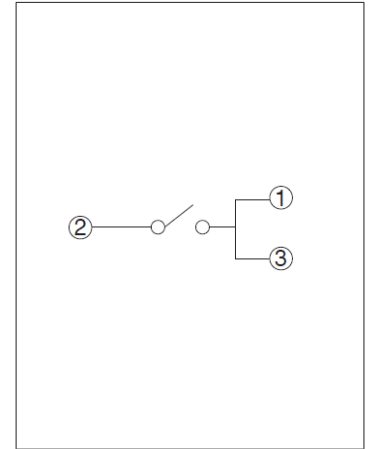

Viewed from direction A in the dimensions.

Drawing No.7

■ Dimensions

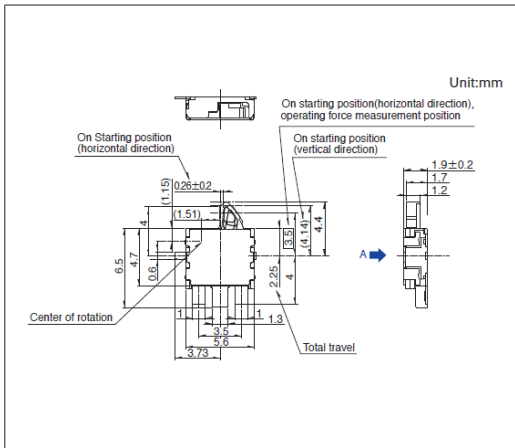

■ Land Dimensions

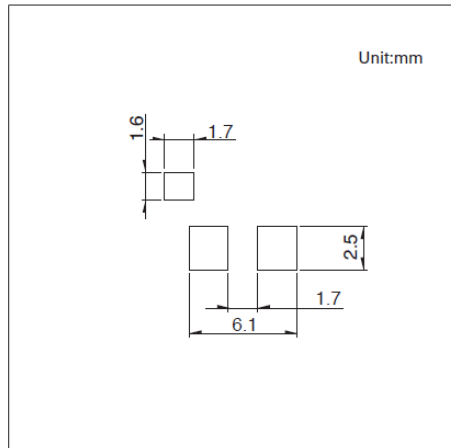

■ Circuit Diagram

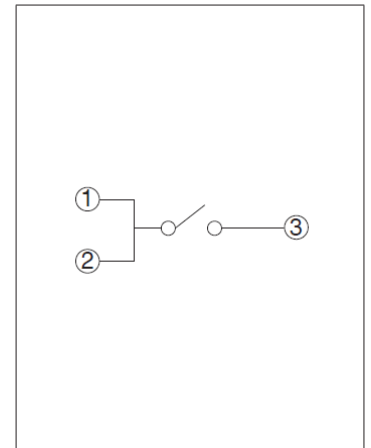

Viewed from direction A in the dimensions.

Drawing No.8

■ Dimensions

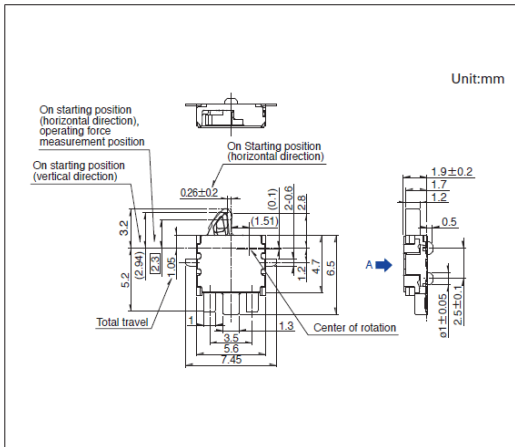

■ Land Dimensions

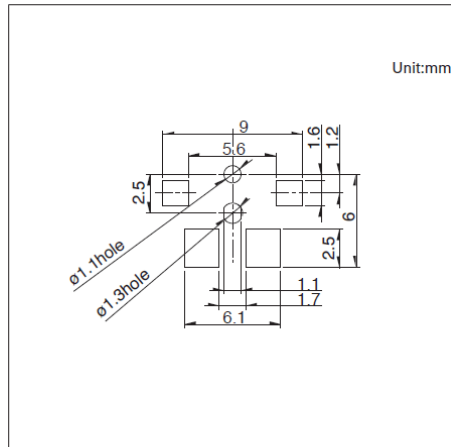

■ Circuit Diagram

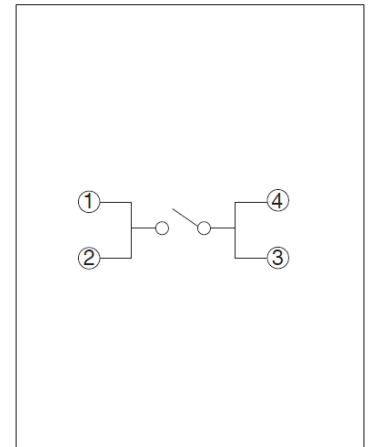

Viewed from direction A in the dimensions.

Two-way Operation
SPVT Series

Drawing No.9

■ Dimensions

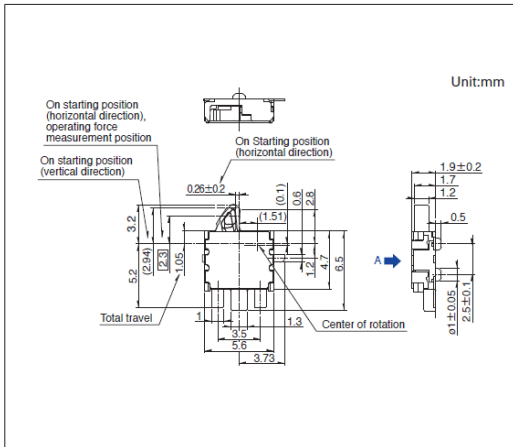

■ Land Dimensions

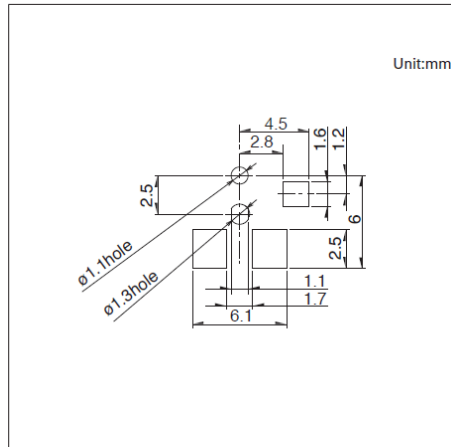

■ Circuit Diagram

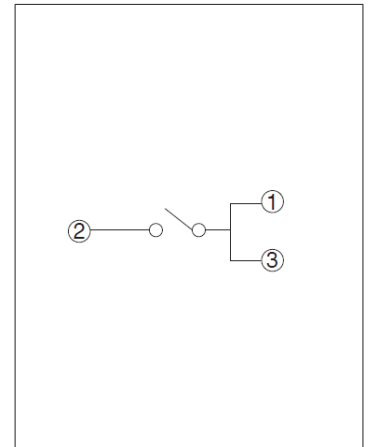

Viewed from direction A in the dimensions.

Drawing No.10

■ Dimensions

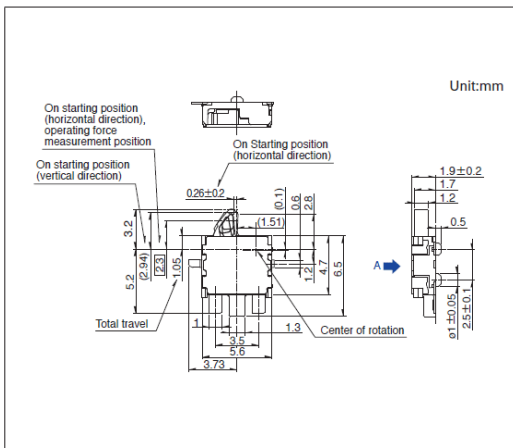

■ Land Dimensions

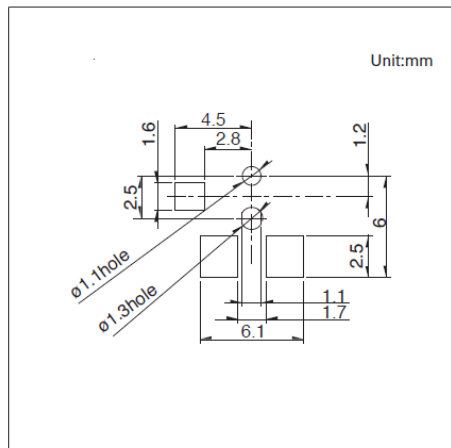

■ Circuit Diagram

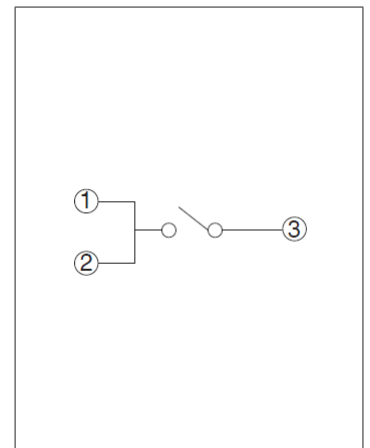

Viewed from direction A in the dimensions.

Drawing No.11

■ Dimensions

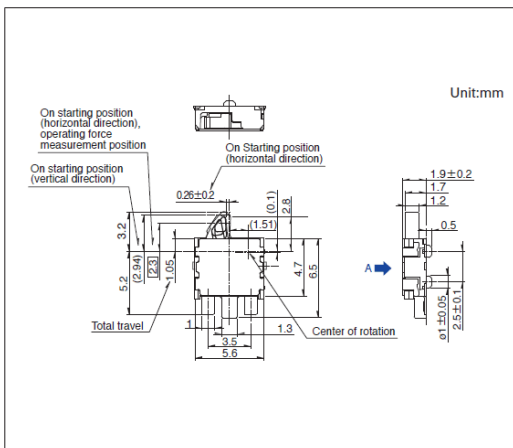

■ Land Dimensions

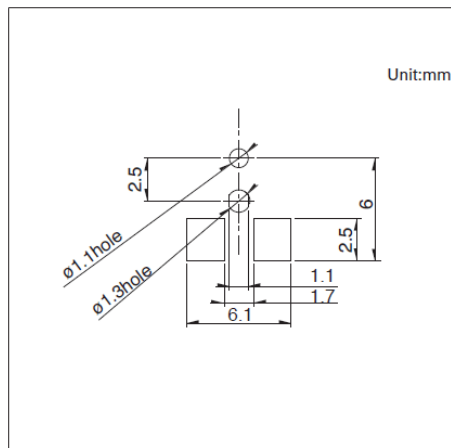

■ Circuit Diagram

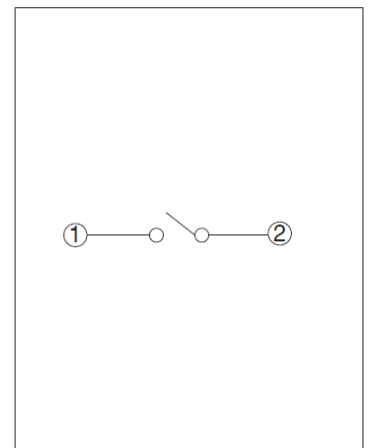

Viewed from direction A in the dimensions.

Two-way Operation
SPVT Series

Drawing No.12

■ Dimensions

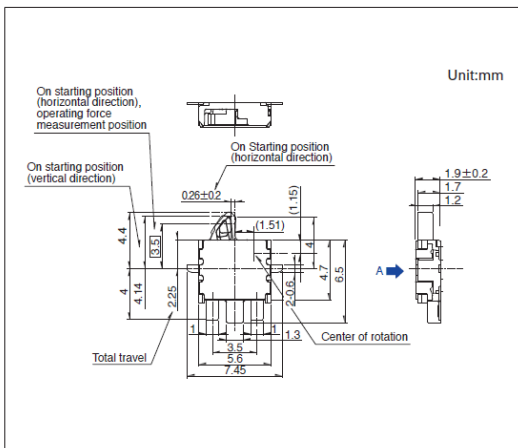

■ Land Dimensions

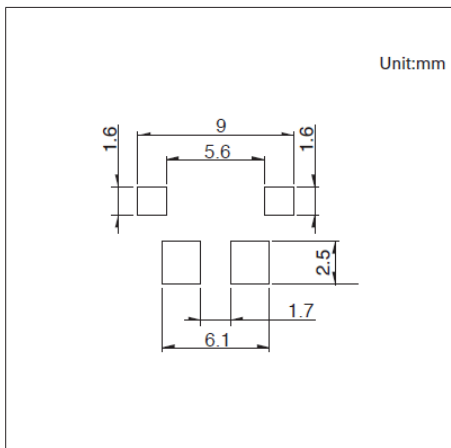

■ Circuit Diagram

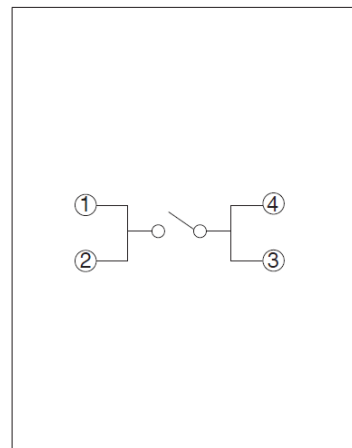

Viewed from direction A in the dimensions.

Drawing No.13

■ Dimensions

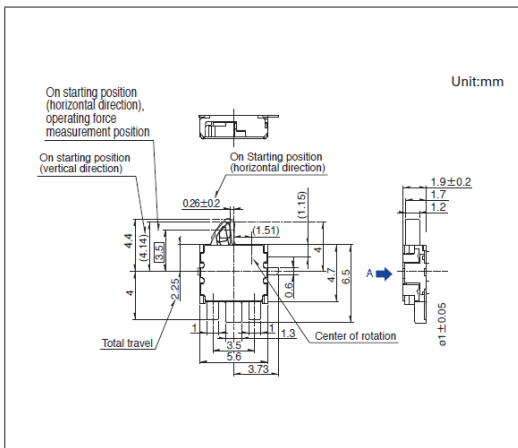

■ Land Dimensions

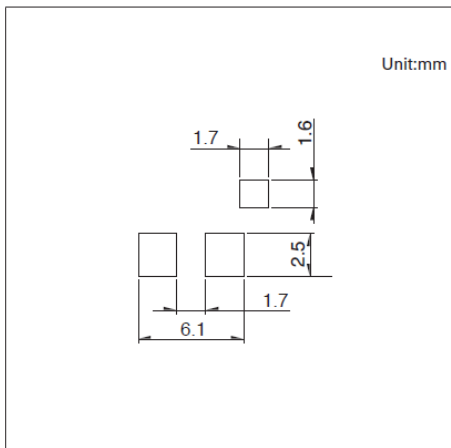

■ Circuit Diagram

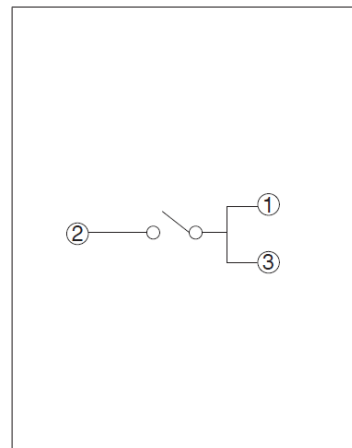

Viewed from direction A in the dimensions.

Drawing No.14

■ Dimensions

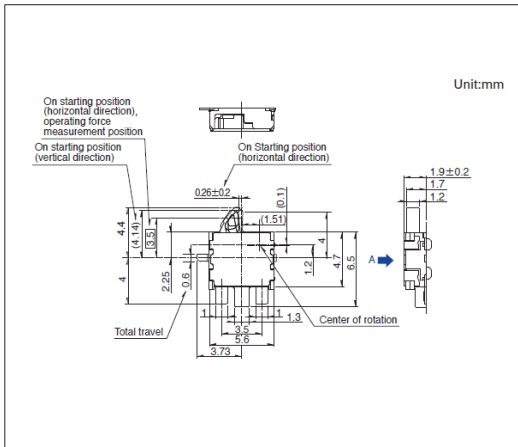

■ Land Dimensions

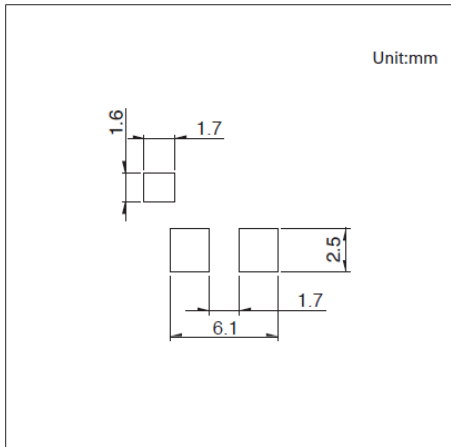

■ Circuit Diagram

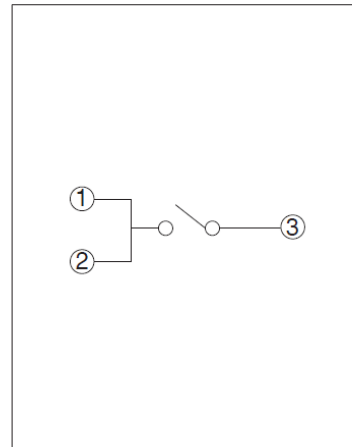

Viewed from direction A in the dimensions.

Compact Two-way Operation SPVM Series

Compact type with a body height of 1.5mm, 3.5×2.8mm, pressable from two directions, vertical and horizontal.



 Automotive

- Rating(max.)/(min.)(Resistive load): 1mA 5V DC/50 μ A 3V DC
- Contact resistance(Initial/After operating life): 2 Ω max./5 Ω max.
- Operating life without load: 50,000 cycles
- Operating life with load Rating(max.)(Resistive load):
50,000 cycles 5 Ω max.

Applications: Mobile: Smartphones, tablets, Notebooks, peripherals
Healthcare: Healthcare equipment
Audio_TV: Cameras
Automotive: Navigation/audio systems, HVAC

Product List

Products No.	Poles	Positions	Operating force	Terminal type	Location lug	Dimensions (W×D×H) (mm)	Water-proof	Dust-proof	Automotive	Drawing No.
SPVM110100	1	1	0.4N max.	For PC board (Reflow)	With	2.8×3.5×1.5	—	—	●	1
SPVM110200	1	1	0.4N max.	For PC board (Reflow)	Without	2.8×3.5×1.5	—	—	●	2

Note

1. This catalog shows only outline specifications. When using the products, please obtain formal specifications for supply.
2. Please place purchase orders per minimum order unit (integer).
3. This products can be used in vehicles.
Although these products are designed to perform over a wide operating temperature range, please ensure that you receive and read the formal delivery specifications before use.
4. For the Terminal Layout, please check our website.

Packing Specifications

Taping

Number of packages (pcs.)			Tape width (mm)	Export package measurements (mm)
1 reel	1 case / Japan	1 case / export packing		
3,000	6,000	12,000	16	417 x 409 x 139

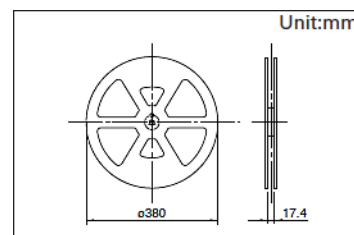

Compact Two-way Operation
SPVM Series

Drawing No.1

■ Dimensions

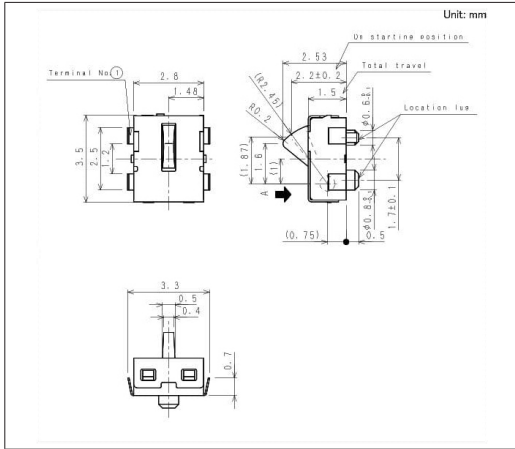

■ Land Dimensions

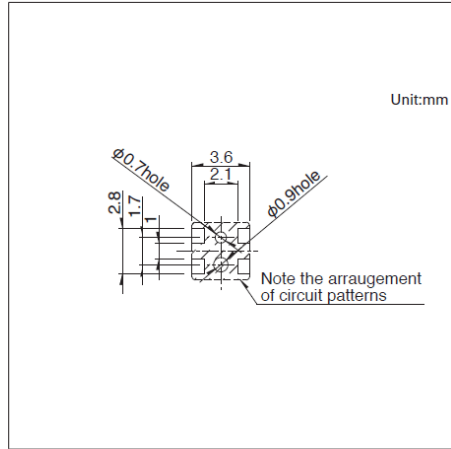

■ Circuit Diagram

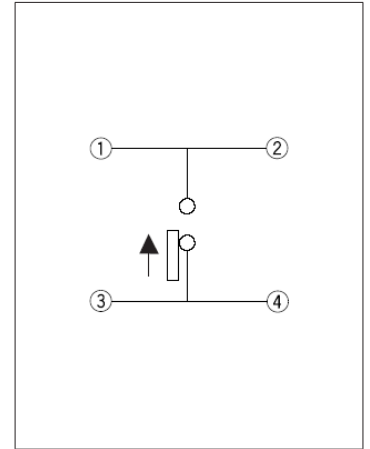

Viewed from direction A in the dimensions.

Drawing No.2

■ Dimensions

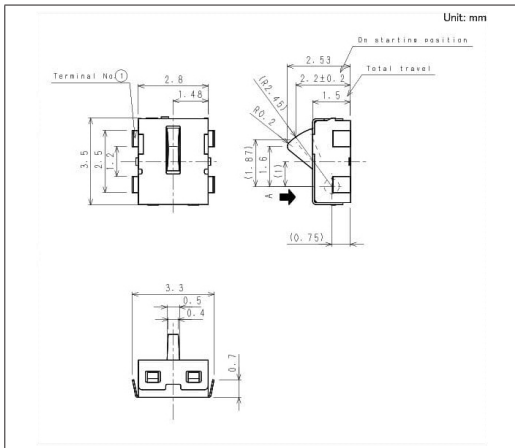

■ Land Dimensions

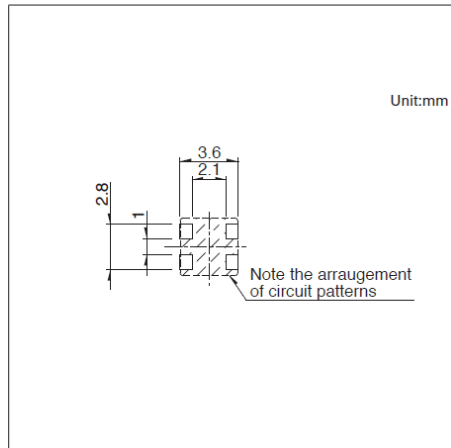

■ Circuit Diagram

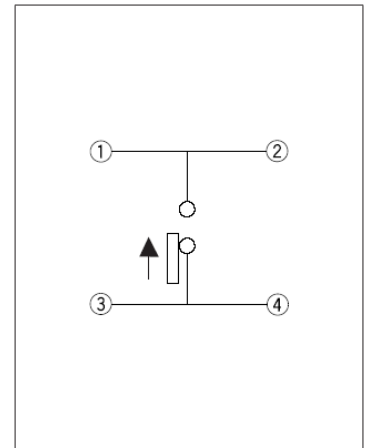

Viewed from direction A in the dimensions.

Low-profile Lever SPVR Series

Thin-profile long-stroke type with a body height of 1.2mm, 4.2×3.6mm.



 Automotive

- Rating(max.)/(min.)(Resistive load): 1mA 5V DC/100 μ A 3V DC
- Contact resistance(Initial/After operating life): 3 Ω max./5 Ω max.
- Operating life without load: 50,000 cycles
- Operating life with load Rating(max.)(Resistive load):
50,000 cycles 5 Ω max.

Applications: Mobile: Smartphones, tablets, Notebooks, peripherals
Healthcare: Healthcare equipment
Audio_TV: Cameras
Automotive: Navigation/audio systems, HVAC

■ Product List

Products No.	Poles	Positions	Operating force	Terminal type	Total travel position	Location lug	Dimensions (W×D×H) (mm)	Water-proof	Dust-proof	Automotive	Drawing No.
SPVR110102	1	1	0.35N max.	For PC board (Reflow)	1.93	With	3.6×4.2×1.2	—	—	●	1
SPVR120102	1	1	0.35N max.	For PC board (Reflow)	1.93	Without	3.6×4.2×1.2	—	—	●	2

Note

1. This catalog shows only outline specifications. When using the products, please obtain formal specifications for supply.
2. Please place purchase orders per minimum order unit (integer).
3. This products can be used in vehicles.
Although these products are designed to perform over a wide operating temperature range, please ensure that you receive and read the formal delivery specifications before use.
4. For the Terminal Layout, please check our website.

■ Packing Specifications

Taping

Number of packages (pcs.)			Tape width (mm)	Export package measurements (mm)
1 reel	1 case / Japan	1 case / export packing		
2,500	5,000	10,000	16	417 x 409 x 139

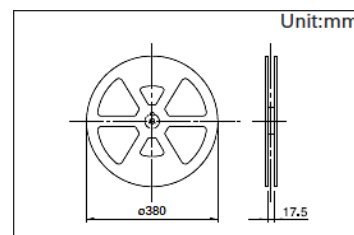

Low-profile Lever
SPVR Series

Drawing No.1

■ Dimensions

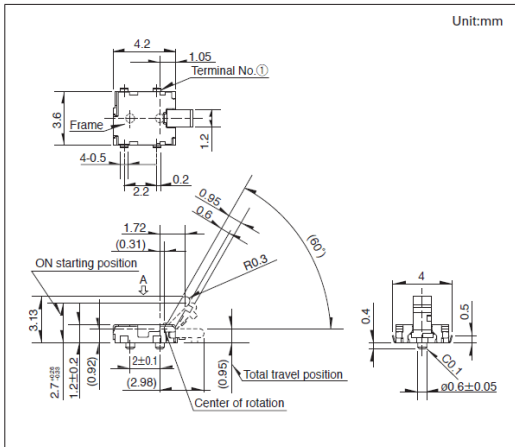

■ Land Dimensions

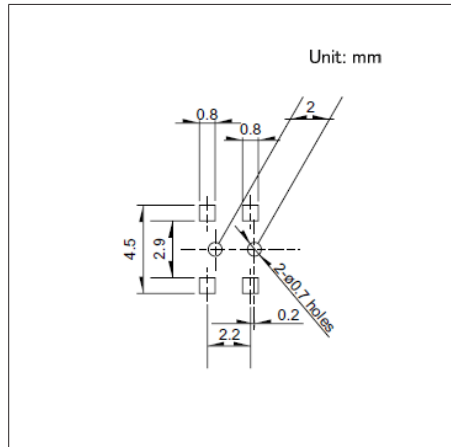

■ Circuit Diagram

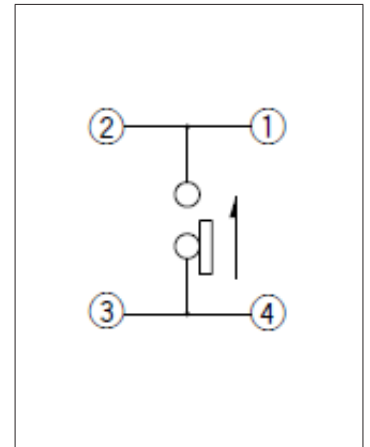

Viewed from direction A in the dimensions.

Drawing No.2

■ Dimensions

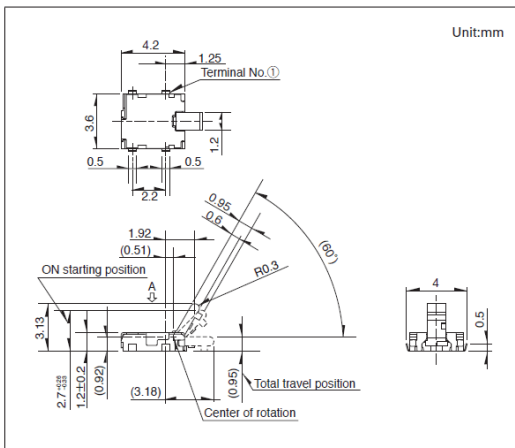

■ Land Dimensions

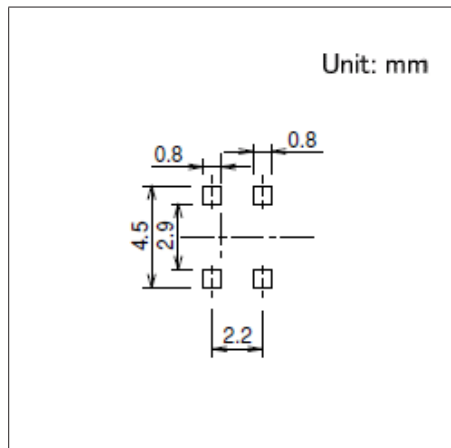

■ Circuit Diagram

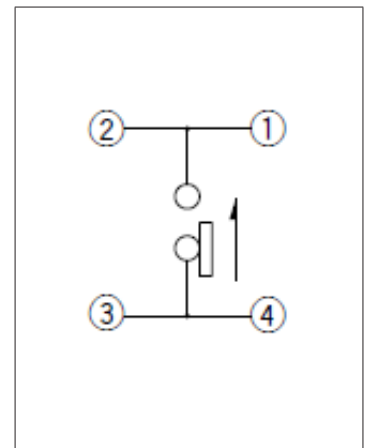

Viewed from direction A in the dimensions.

Switches

Detector Switches

Compact One-way Operation
SPVE Series

Industry's smallest class type with dimensions of 3.4×3.0mm.

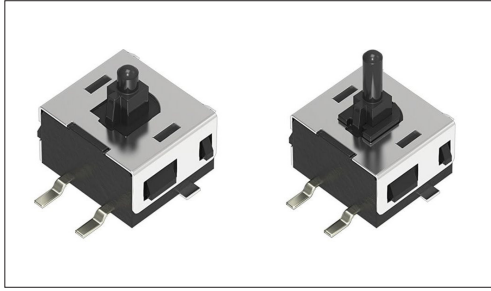

- Rating(max.)/(min.)(Resistive load):0.1A 30V DC/50μA 3V DC
- Contact resistance(Initial/After operating life):500mΩ max./1Ω max.
- Operating life without load:50,000 cycles
- Operating life with load Rating(max.)(Resistive load):
50,000 cycles 1Ω max.

Applications: Mobile: Smartphones, tablets, Notebooks, peripherals
Audio_TV: Cameras

■ Product List

Products No.	Poles	Positions	Operating force	Terminal type	Slider height	ON start position	Total travel position	Location lug	Dimensions (W×D×H) (mm)	Water-proof	Dust-proof	Automotive	Drawing No.
SPVE110100	1	1	0.3N max.	For PC board (Reflow)	3.8	3.5	2.5	Without	3.4×3.0×2.3	—	—	—	1
SPVE110600	1	1	0.3N max.	For PC board (Reflow)	3.8	3.5	2.5	With	3.4×3.0×2.3	—	—	—	2
SPVE110401	1	1	0.3N max.	For PC board (Reflow)	4.1	3.8	2.9	Without	3.4×3.0×2.3	—	—	—	3
SPVE110801	1	1	0.3N max.	For PC board (Reflow)	4.1	3.8	2.9	With	3.4×3.0×2.3	—	—	—	4
SPVE110200	1	1	0.3N max.	For PC board (Reflow)	4.8	4.5	3.6	Without	3.4×3.0×2.3	—	—	—	5
SPVE110900	1	1	0.3N max.	For PC board (Reflow)	4.8	4.5	3.6	With	3.4×3.0×2.3	—	—	—	6
SPVE111300	1	1	0.3N max.	For PC board (Reflow)	5.2	4.9	4.0	With	3.4×3.0×2.3	—	—	—	7
SPVE111200	1	1	0.3N max.	For PC board (Reflow)	5.5	5.2	4.3	With	3.4×3.0×2.3	—	—	—	8
SPVE210100	1	1	0.3N max.	For PC board (Reflow)	3.3	3.0	2.0	—	3.4×4.0×1.8	—	—	—	9

⚠ Note

1. This catalog shows only outline specifications. When using the products, please obtain formal specifications for supply.
2. Please place purchase orders for taping products per minimum order unit (1 reel or a case).
3. For the Terminal Layout, please check our website.

■ Packing Specifications

Taping

Products No.	Number of packages(pcs.)			Tape width (mm)	Export package measurements (mm)
	1 reel	1 case / Japan	1 case / export packing		
SPVE110100 SPVE110600 SPVE110401 SPVE110801 SPVE210100	2,800	5,600	22,400	12	406×406×190
SPVE110200 SPVE110900	2,200	4,400	17,600	12	406×406×190
SPVE111300 SPVE111200	2,000	4,000	16,000	12	406×406×190

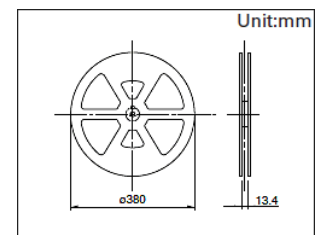

Compact One-way Operation
SPVE Series

Drawing No.1

■ Dimensions

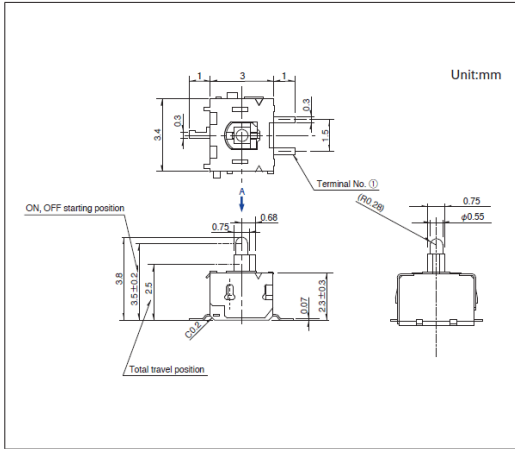

■ Land Dimensions

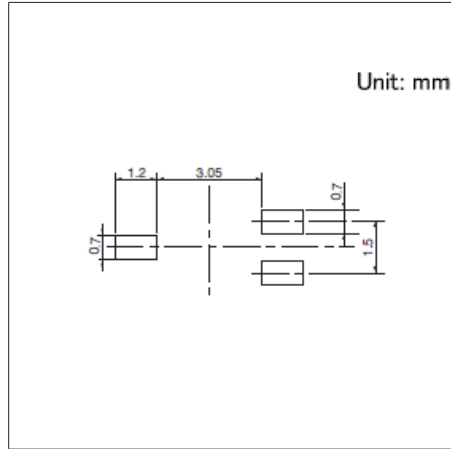

■ Circuit Diagram

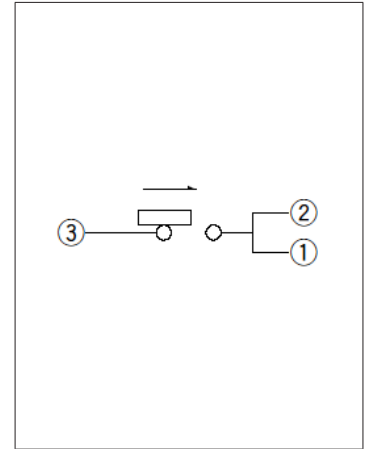

Viewed from direction A in the dimensions.

Drawing No.2

■ Dimensions

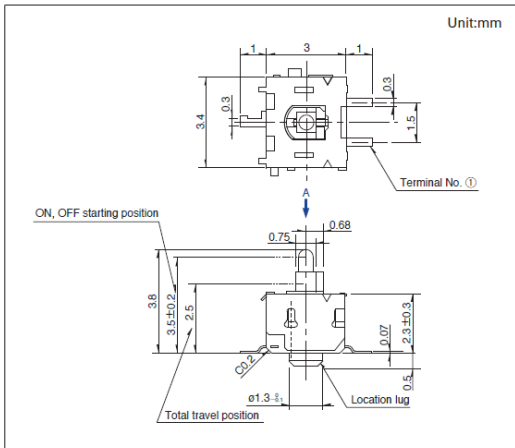

■ Land Dimensions

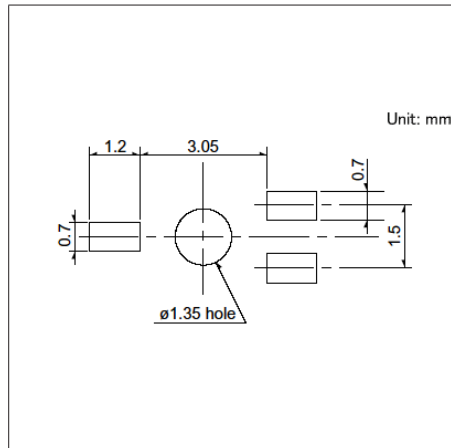

■ Circuit Diagram

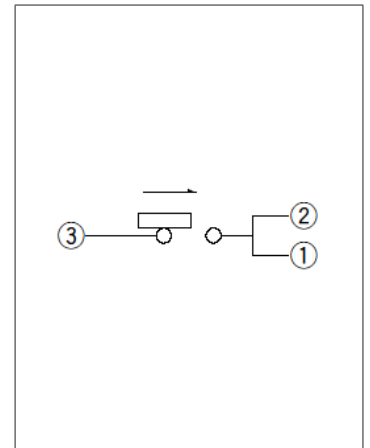

Viewed from direction A in the dimensions.

Drawing No.3

■ Dimensions

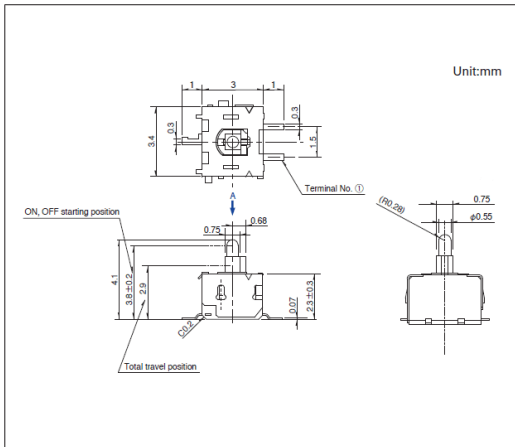

■ Land Dimensions

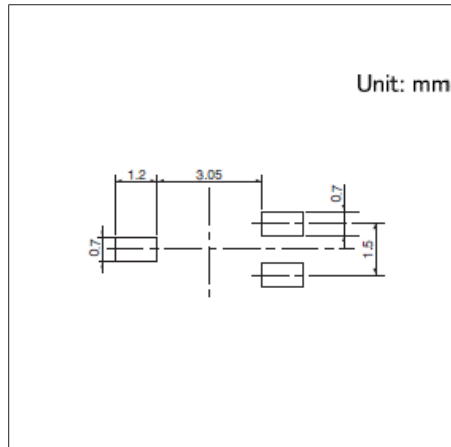

■ Circuit Diagram

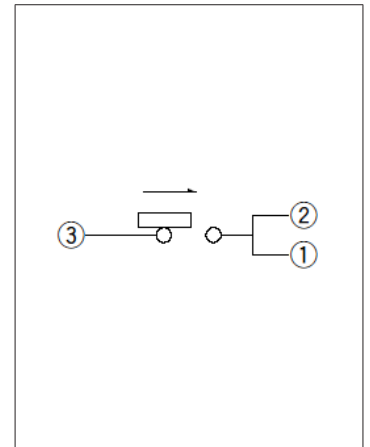

Viewed from direction A in the dimensions.

Compact One-way Operation
SPVE Series

Drawing No.4

■ Dimensions

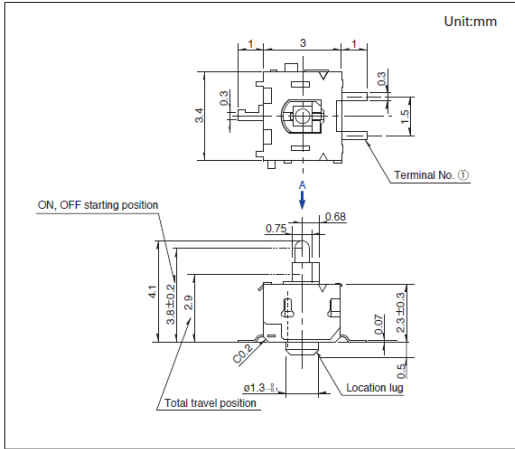

■ Land Dimensions

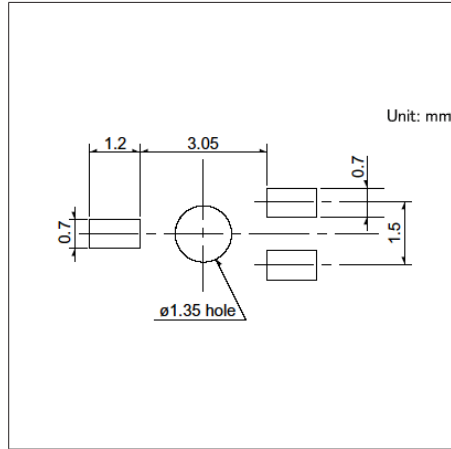

■ Circuit Diagram

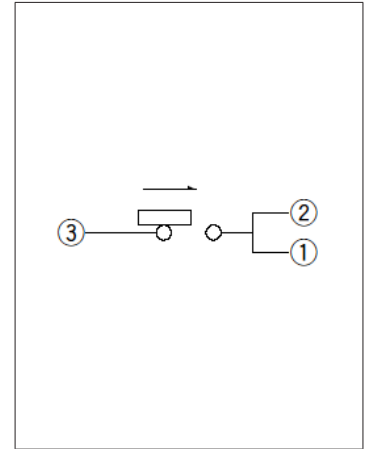

Viewed from direction A in the dimensions.

Drawing No.5

■ Dimensions

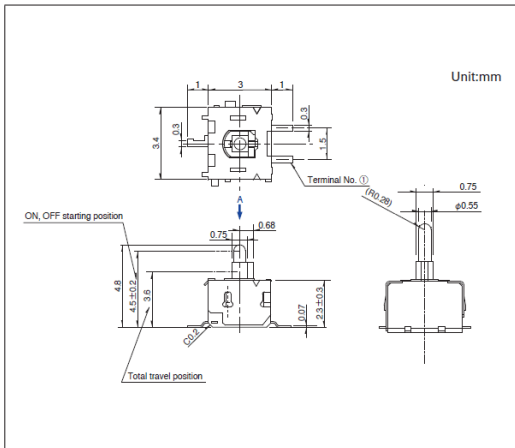

■ Land Dimensions

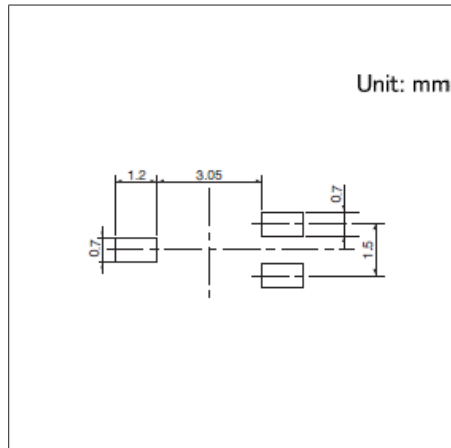

■ Circuit Diagram

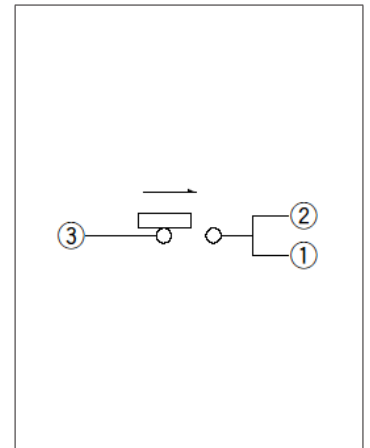

Viewed from direction A in the dimensions.

Drawing No.6

■ Dimensions

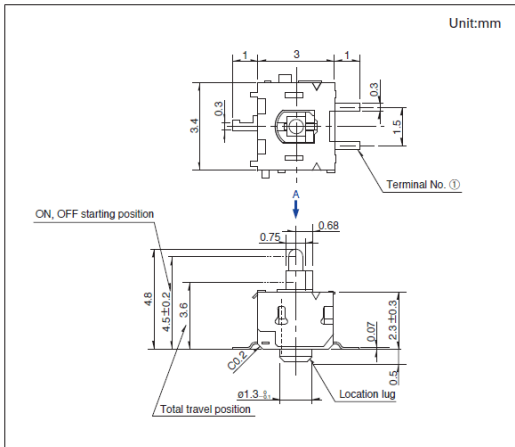

■ Land Dimensions

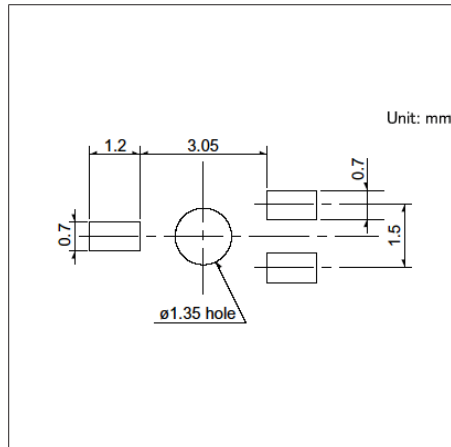

■ Circuit Diagram

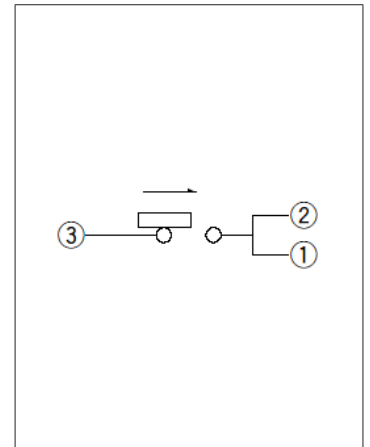

Viewed from direction A in the dimensions.

Compact One-way Operation
SPVE Series

Drawing No.7

■ Dimensions

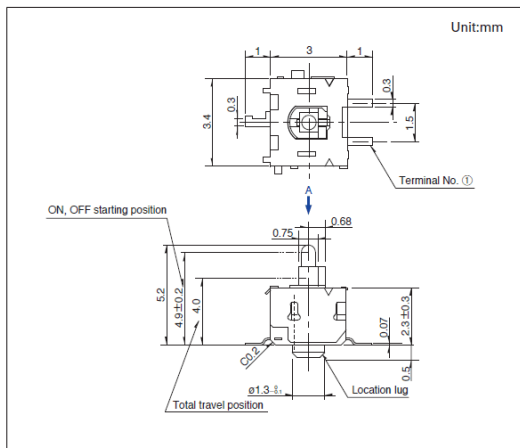

■ Land Dimensions

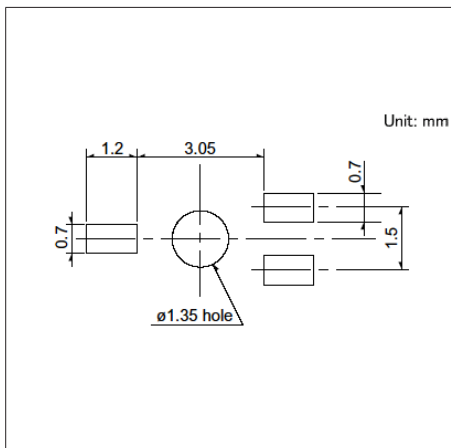

■ Circuit Diagram

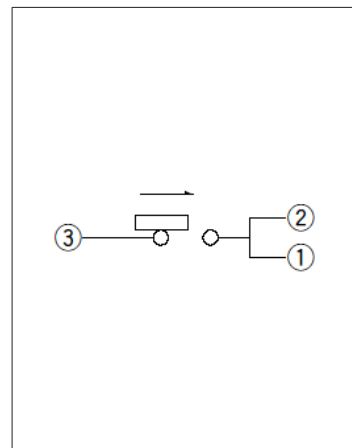

Viewed from direction A in the dimensions.

Drawing No.8

■ Dimensions

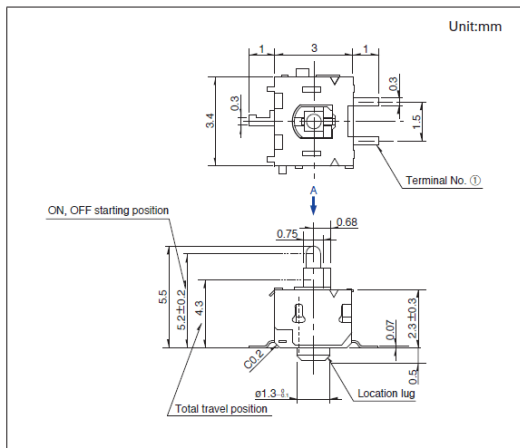

■ Land Dimensions

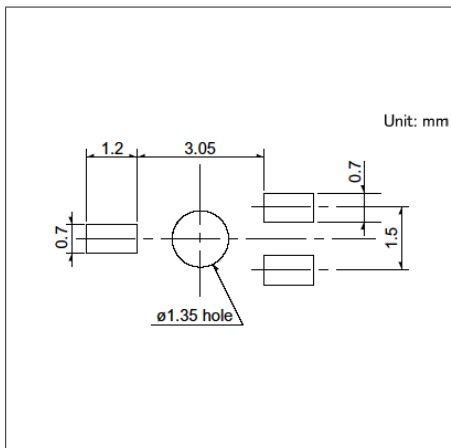

■ Circuit Diagram

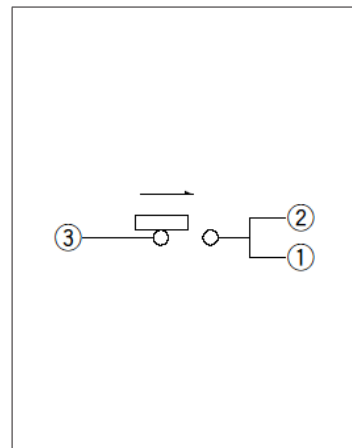

Viewed from direction A in the dimensions.

Drawing No.9

■ Dimensions

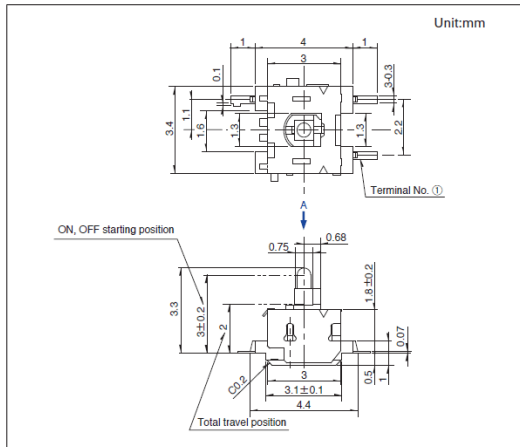

■ Land Dimensions

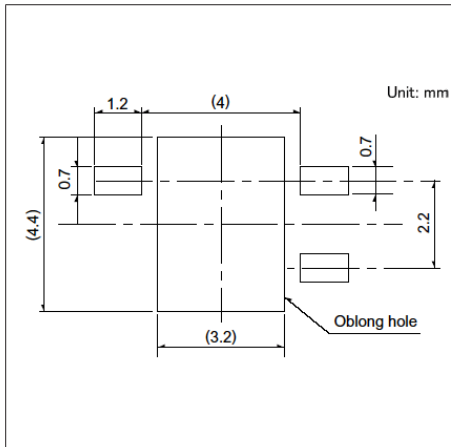

■ Circuit Diagram

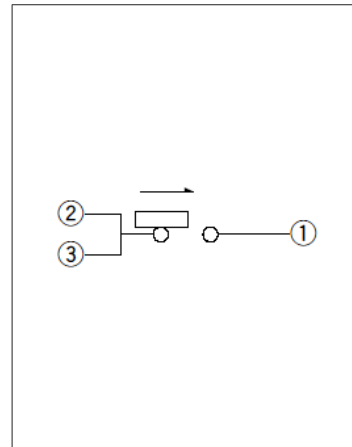

Viewed from direction A in the dimensions.

Switches **Detector Switches**

Compact Two-way, Two-step Detection
SSCQ Series

Two-stage detection type, 30% smaller than conventional products, among the smallest in the industry.

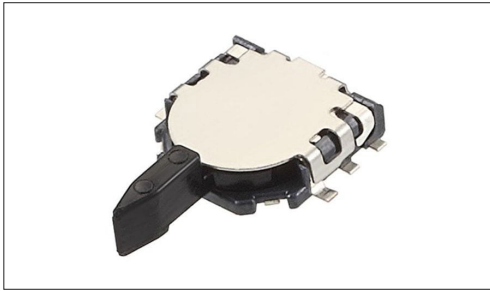

- Rating(max.)/(min.)(Resistive load): 1mA 5V DC/50μA 3V DC
- Contact resistance(Initial/After operating life): 2Ω max./5Ω max.
- Operating life without load: 50,000 cycles
- Operating life with load Rating(max.)(Resistive load):
50,000 cycles 5Ω max.

Applications: Audio_TV: Cameras

■ Product List

Products No.	Poles	Positions	Operating force	Total travel position	Location lug	Dimensions (W×D×H) (mm)	Water-proof	Dust-proof	Automotive	Drawing No.
SSCQ110100	1	Two-direction, 2-positions each side	0.35N max.	3.73	With	3.8×3.6×0.9	—	—	—	1
SSCQ120102	1	Two-direction, 2-positions each side	0.35N max.	3.73	Without	3.8×3.6×0.9	—	—	—	2

⚠ Note

1. This catalog shows only outline specifications. When using the products, please obtain formal specifications for supply.
2. Please place purchase orders for taping products per minimum order unit (1 reel or a case).
3. For the Terminal Layout, please check our website.

■ Packing Specifications

Taping

Number of packages (pcs.)			Tape width (mm)	Export package measurements (mm)
1 reel	1 case / Japan	1 case / export packing		
4,000	8,000	16,000	16	417 x 409 x 139

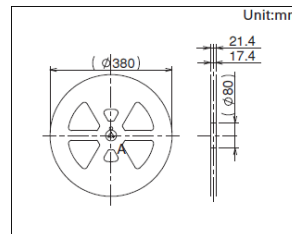

Drawing No.1

■ Dimensions

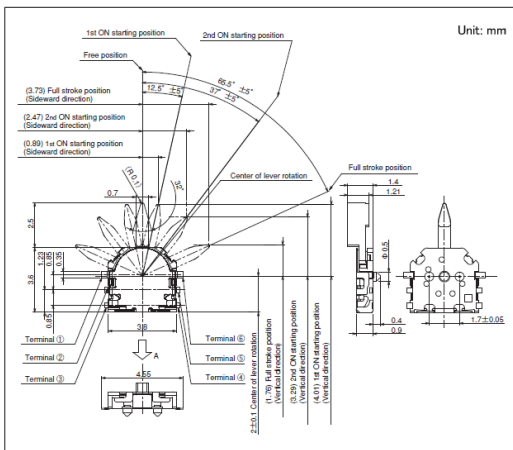

■ Land Dimensions

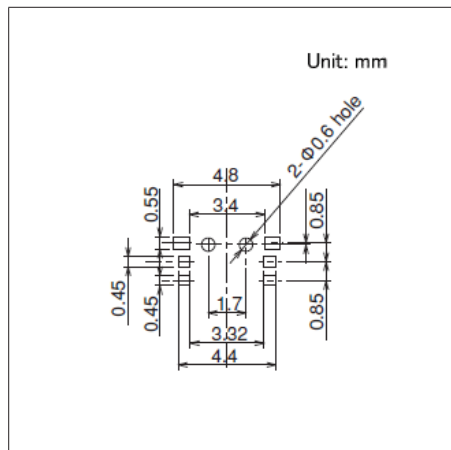

■ Circuit Diagram

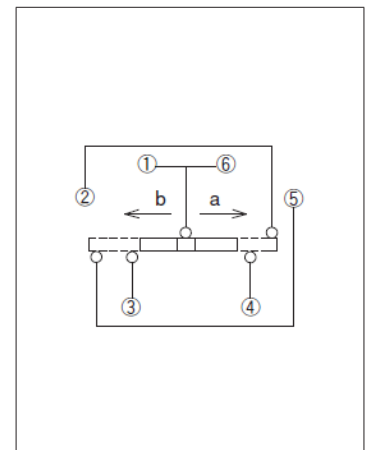

Compact Two-way, Two-step Detection SSCQ Series

Drawing No.2

■ Dimensions

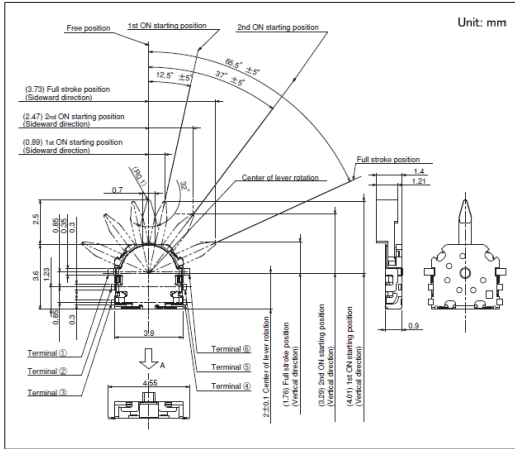

■ Land Dimensions

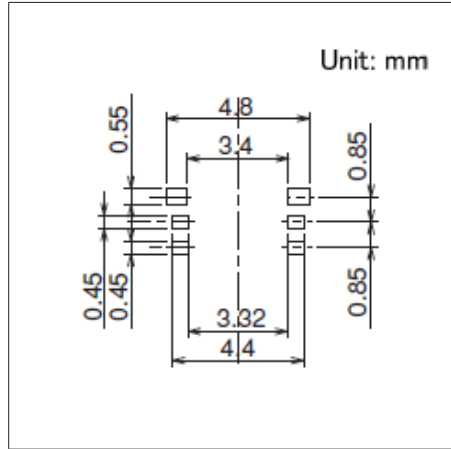

■ Circuit Diagram

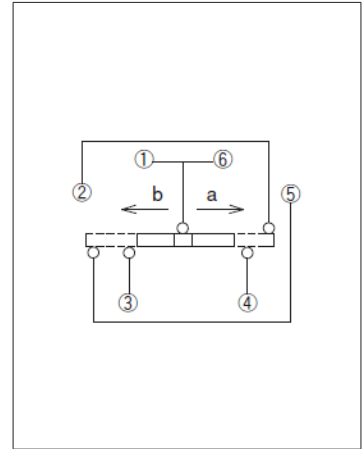

Switches **Detector Switches**

Compact Two-way Detection
SSCM Series

Thin-profile type with a body height of 1.5mm, capable of detecting two lateral directions.



- Rating(max.)/(min.)(Resistive load): 1mA 5V DC/50μA 3V DC
- Contact resistance(Initial/After operating life): 2Ω max./5Ω max.
- Operating life without load: 50,000 cycles
- Operating life with load Rating(max.)(Resistive load):
50,000 cycles 5Ω max.

Applications: Mobile: Smartphones, tablets, Headsets, wearables,
Notebooks, peripherals
Game: Home handheld consoles, Virtual/augmented reality
Healthcare: Healthcare equipment
Audio_TV: Audio, Cameras

■ Product List

Products No.	Poles	Positions	Operating force	Terminal type	Total travel position	Location lug	Dimensions (W×D×H) (mm)	Water-proof	Dust-proof	Automotive	Drawing No.
SSCM110100	1	2	0.35N max.	For PC board (Reflow)	1.57	With	4.0×5.0×1.5	—	—	—	1
SSCM120100	1	2	0.35N max.	For PC board (Reflow)	1.57	Without	4.0×5.0×1.5	—	—	—	2

Note

1. This catalog shows only outline specifications. When using the products, please obtain formal specifications for supply.
2. Please place purchase orders for taping products per minimum order unit (1 reel or a case).
3. For the Terminal Layout, please check our website.

■ Packing Specifications

Taping

Number of packages (pcs.)			Tape width (mm)	Export package measurements (mm)
1 reel	1 case / Japan	1 case / export packing		
3,000	6,000	12,000	16	417 x 409 x 139

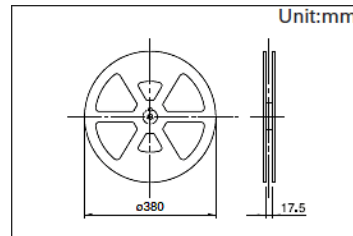

Drawing No.1

■ Dimensions

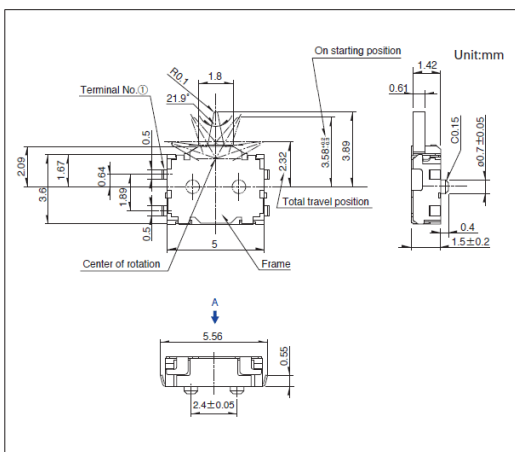

■ Land Dimensions

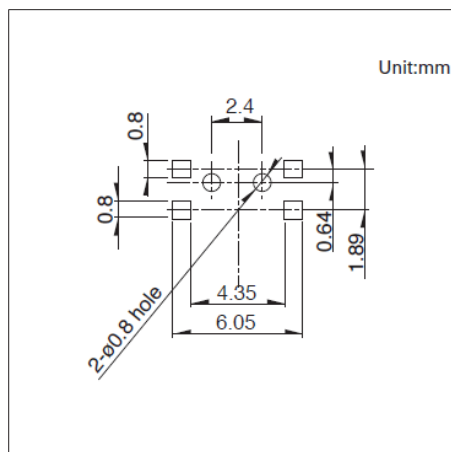

■ Circuit Diagram

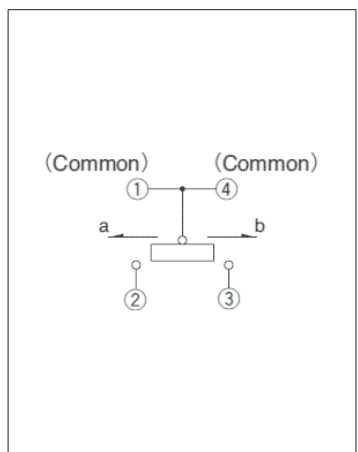

Viewed from direction A in the dimensions.

Compact Two-way Detection
SSCM Series

Drawing No.2

■ Dimensions

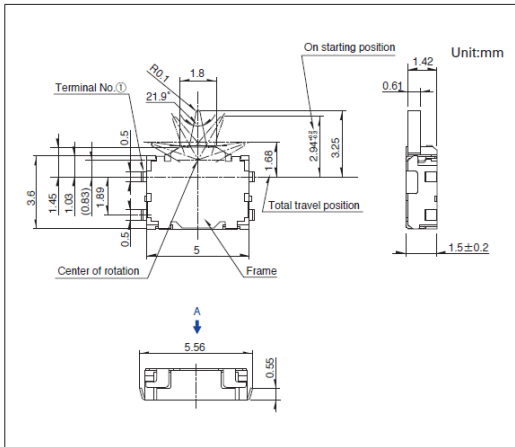

■ Land Dimensions

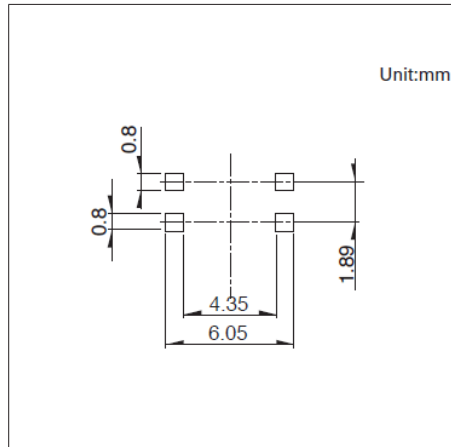

■ Circuit Diagram

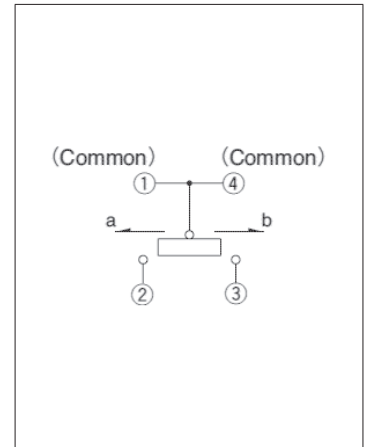

Viewed from direction A in the dimensions.

Low-profile Tri-directional Operation

SPVL Series

Thin-profile type with a body height of 1.0mm, offering 180° flexible operation.

 Automotive

- Rating(max.)/(min.)(Resistive load): 1mA 5V DC/50 μ A 3V DC
- Contact resistance(Initial/After operating life): 2 Ω max./5 Ω max.
- Operating life without load: 50,000 cycles
- Operating life with load Rating(max.)(Resistive load):
50,000 cycles 5 Ω max.

Applications: Mobile: Smartphones, tablets, Notebooks, peripherals
 Healthcare: Healthcare equipment
 Audio_TV: Cameras
 Automotive: Navigation/audio systems, HVAC

■ Product List

Products No.	Poles	Positions	Operating force	Terminal type	Location lug	Dimensions (W×D×H) (mm)	Water-proof	Dust-proof	Automotive	Drawing No.
SPVL110102	1	1	0.35N max.	For PC board (Reflow)	With	6.6×5.55×1.0	—	—	●	1
SPVL120101	1	1	0.35N max.	For PC board (Reflow)	Without	6.6×5.55×1.0	—	—	●	2

 Note

1. This catalog shows only outline specifications. When using the products, please obtain formal specifications for supply.
2. Please place purchase orders per minimum order unit (integer).
3. This products can be used in vehicles.
Although these products are designed to perform over a wide operating temperature range, please ensure that you receive and read the formal delivery specifications before use.
4. For the Terminal Layout, please check our website.

■ Packing Specifications

Taping

Number of packages (pcs.)			Tape width (mm)	Export package measurements (mm)
1 reel	1 case / Japan	1 case / export packing		
5,000	10,000	20,000	16	417 x 409 x 139

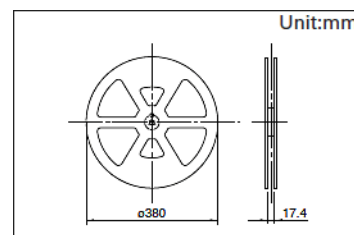

Low-profile Tri-directional Operation
SPVL Series

Drawing No.1

■ Dimensions

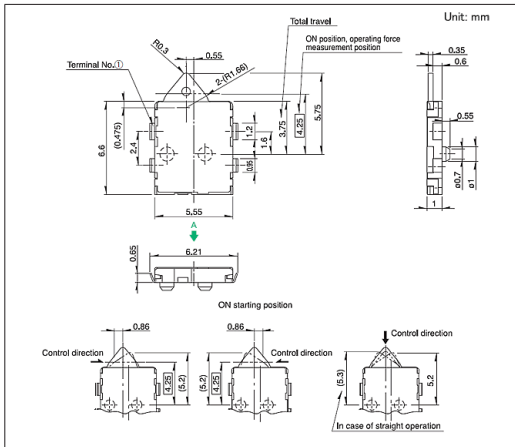

■ Land Dimensions

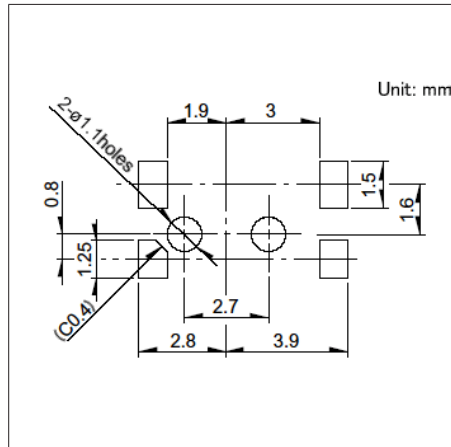

■ Circuit Diagram

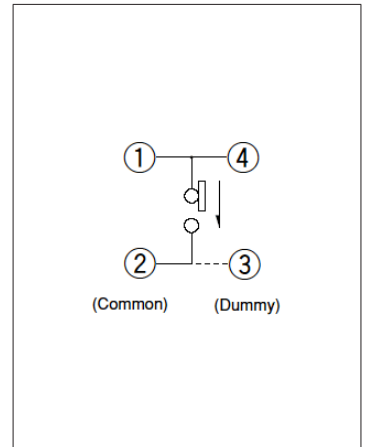

Viewed from direction A in the dimensions.

Drawing No.2

■ Dimensions

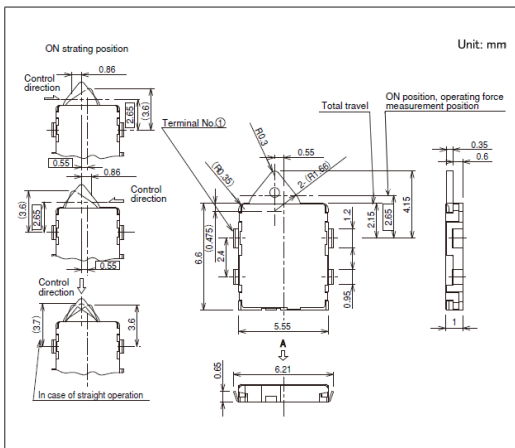

■ Land Dimensions

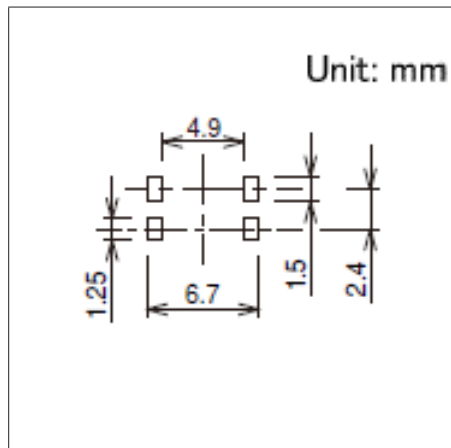

■ Circuit Diagram

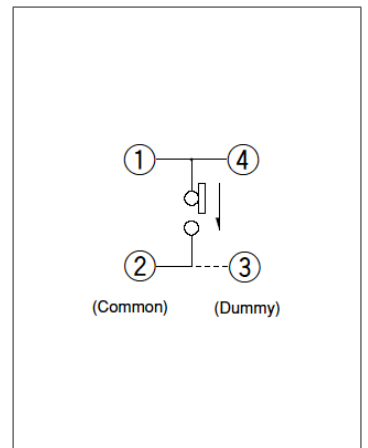

Viewed from direction A in the dimensions.

Switches **Detector Switches**General-purpose Type
SPPB Series

Wide product variety supporting various digital devices.

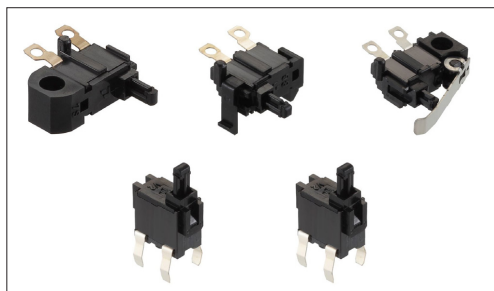

Automotive

- Rating(max.)/(min.)(Resistive load):0.1 A 30V DC/50 μ A 3V DC
- Contact resistance(Initial/After operating life): 1 Ω max./2 Ω max.
- Operating life without load:50,000 cycles
- Operating life with load Rating(max.)(Resistive load):
50,000 cycles 2 Ω max.

Applications:Healthcare:Healthcare equipment
Home:Major home appliances
Audio_TV:Audio
Automotive:Navigation/audio systems, HVAC

■ Product List

Products No.	Poles	Positions	Operating force	Operation part shape	Terminal type	Dimensions (W×D×H) (mm)	Water-proof	Dust-proof	Automotive	Drawing No.
SPPB110300	1	1	0.35N max.	Push	For Lead	9.7×3.75×5.1	—	—	●	1
SPPB120200	1	1	0.35N max.	Push	For Lead	9.7×3.75×5.1	—	—	●	2
SPPB310400	1	1	0.35N max.	Push	For Lead	8.8×3.5×5.1	—	—	●	3
SPPB320100	1	1	0.35N max.	Push	For Lead	8.8×3.5×5.1	—	—	●	4
SPPB1A0100	1	1	0.35N max.	Actuator A	For Lead	9.75×3.75×5.7	—	—	●	5
SPPB1A0101	1	1	0.35N max.	Actuator A	For Lead	9.75×3.75×5.7	—	—	●	6
SPPB2A0100	1	1	0.35N max.	Actuator C	For Lead	9.75×3.75×5.7	—	—	●	7
SPPB2A0101	1	1	0.35N max.	Actuator C	For Lead	9.75×3.75×5.7	—	—	●	8
SPPB512300	1	1	0.35N max.	Push	For PC board (Dip)	6.3×3.0×4.9	—	—	●	9
SPPB610400	1	1	0.35N max.	Push	For PC board (Dip)	6.3×5.1×3.7	—	—	●	10
SPPB620300	1	1	0.35N max.	Push	For PC board (Dip)	6.3×5.1×3.7	—	—	●	11
SPPB5A0100	1	1	0.35N max.	Actuator A	For PC board (Dip)	9.15×3.75×5.5	—	—	●	12
SPPB6A0100	1	1	0.35N max.	Actuator A	For PC board (Dip)	10.0×6.1×5.25	—	—	●	13
SPPB6A0400	1	1	0.35N max.	Actuator A	For PC board (Dip)	10.0×6.1×5.25	—	—	●	14
SPPB530701	1	1	0.35N max.	Push	For PC board (Reflow)	6.5×3.1×4.9	—	—	●	15
SPPB530601	1	1	0.35N max.	Push	For PC board (Reflow)	6.4×3.0×4.9	—	—	●	16
SPPB630101	1	1	0.35N max.	Push	For PC board (Reflow)	6.3×6.1×4.25	—	—	●	17
SPPB640201	1	1	0.35N max.	Push	For PC board (Reflow)	6.3×6.1×4.25	—	—	●	18

Note

1. This catalog shows only outline specifications. When using the products, please obtain formal specifications for supply.
2. Please place purchase orders per minimum order unit (integer).
3. Please place purchase orders for taping products per minimum order unit (1 reel or a case).
4. This products can be used in vehicles.

Although these products are designed to perform over a wide operating temperature range, please ensure that you receive and read the formal delivery specifications before use.

General-purpose Type
SPPB Series

■ Packing Specifications

Bulk

Products No.	Number of packages(pcs.)		Export package measurements (mm)
	1 case / Japan	1 case / export packing	
SPPB110300 SPPB120200 SPPB310400 SPPB320100 SPPB610400 SPPB620300	2,000	10,000	400 x 270 x 290
SPPB1A0100 SPPB1A0101 SPPB2A0100 SPPB2A0101 SPPB5A0100 SPPB6A0100 SPPB6A0400	1,000	5,000	400 x 270 x 290
SPPB512300	4,000	20,000	400 x 270 x 290

Taping

Products No.	Number of packages(pcs.)			Tape width (mm)	Export package measurements (mm)
	1 reel	1 case / Japan	1 case / export packing		
SPPB530701	1,500	3,000	6,000	24	406×406×160
SPPB530601	600	1,200	2,400	24	406×406×160
SPPB630101 SPPB640201	1,300	2,600	5,200	24	406×406×160

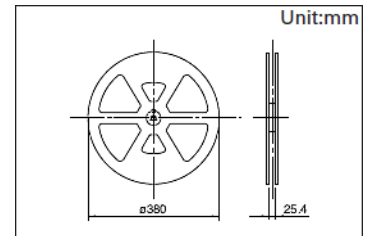

Drawing No.1

■ Dimensions

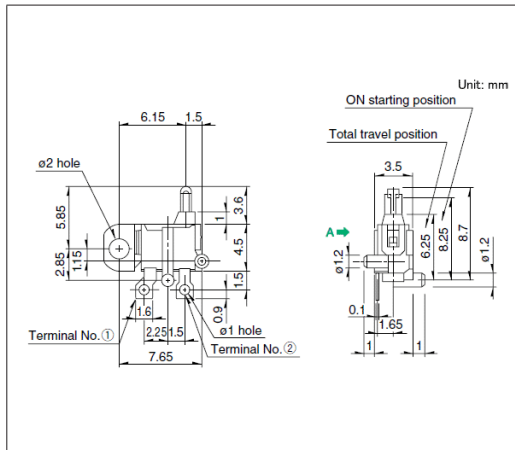

■ Mounting Hole Dimensions

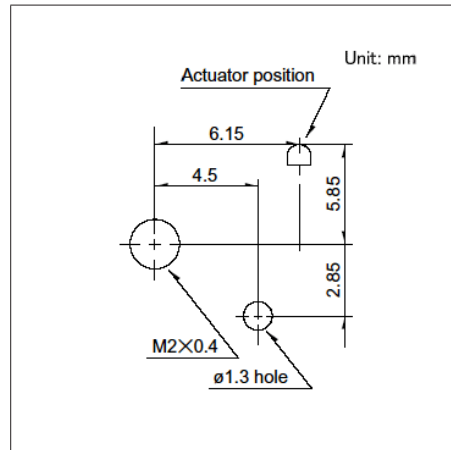

■ Circuit Diagram

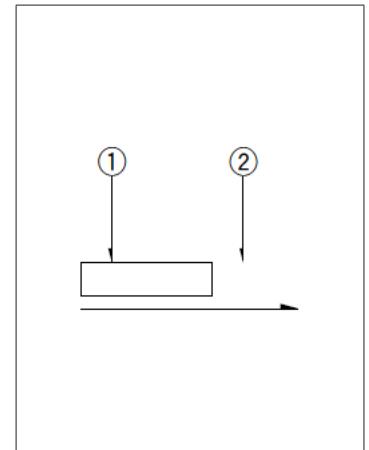

Viewed from direction A in the dimensions.

General-purpose Type
SPPB Series

Drawing No.2

■ Dimensions

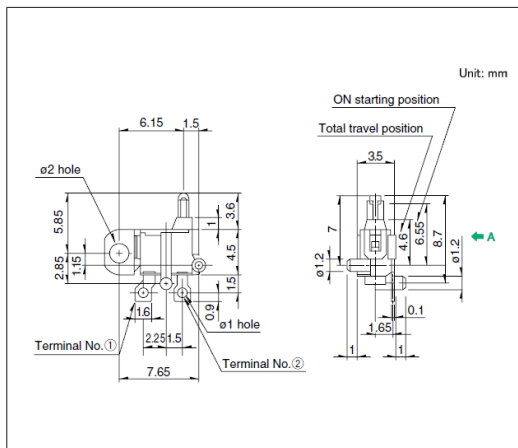

■ Mounting Hole Dimensions

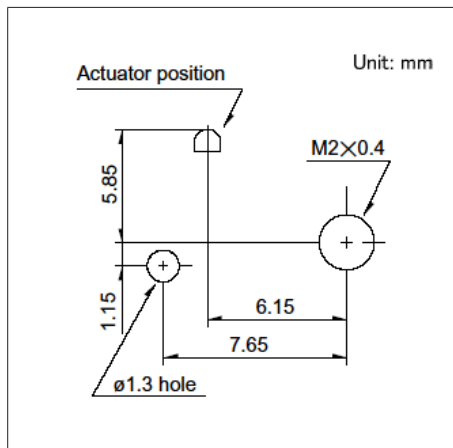

■ Circuit Diagram

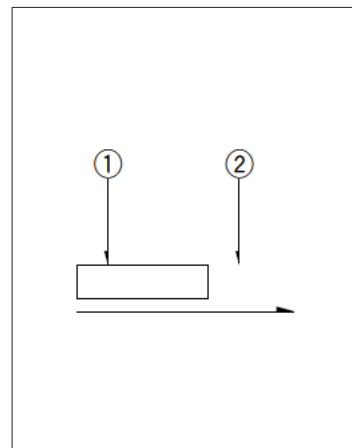

Viewed from direction A in the dimensions.

Drawing No.3

■ Dimensions

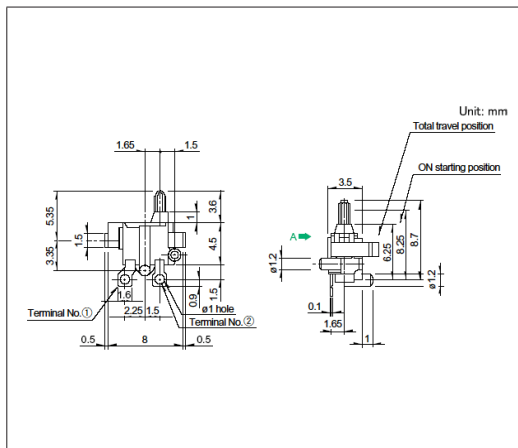

■ Mounting Hole Dimensions

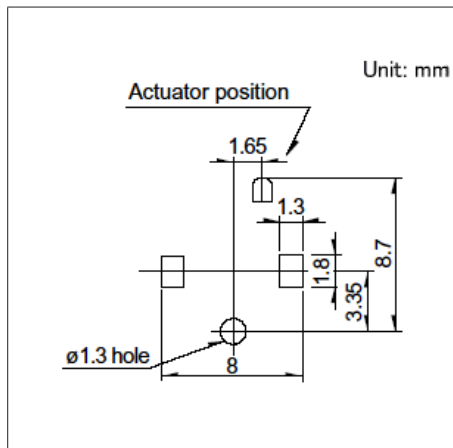

■ Circuit Diagram

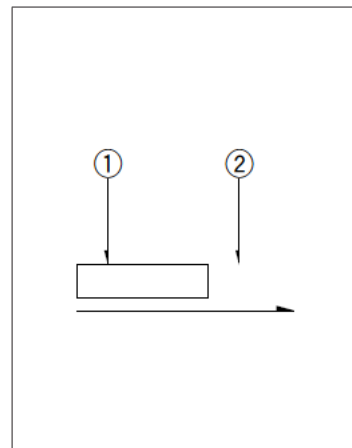

Viewed from direction A in the dimensions.

Drawing No.4

■ Dimensions

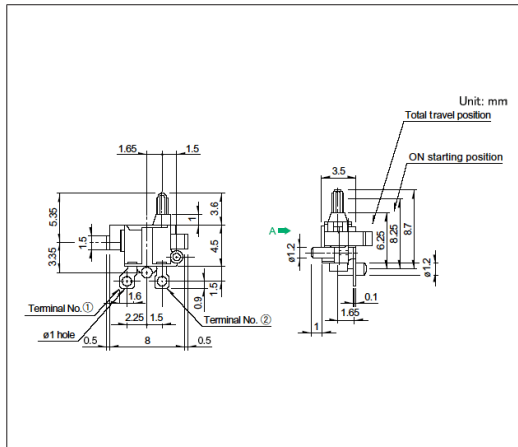

■ Mounting Hole Dimensions

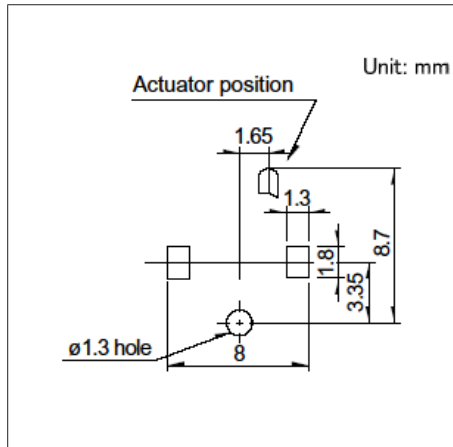

■ Circuit Diagram

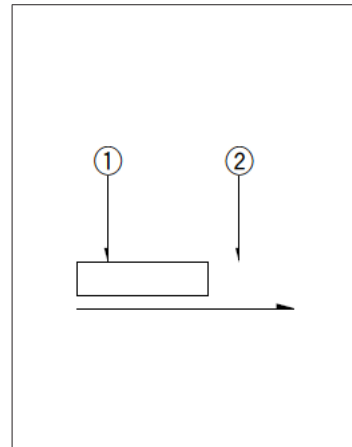

Viewed from direction A in the dimensions.

General-purpose Type
SPPB Series

Drawing No.5

■ Dimensions

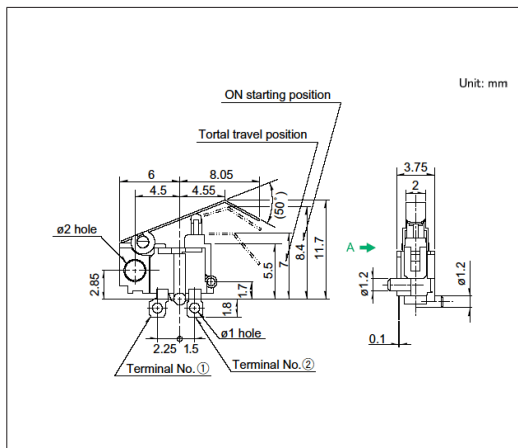

■ Mounting Hole Dimensions

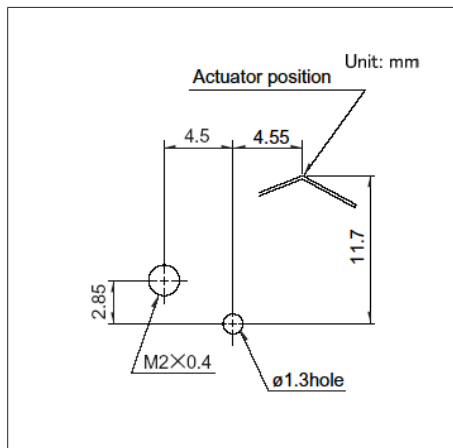

■ Circuit Diagram

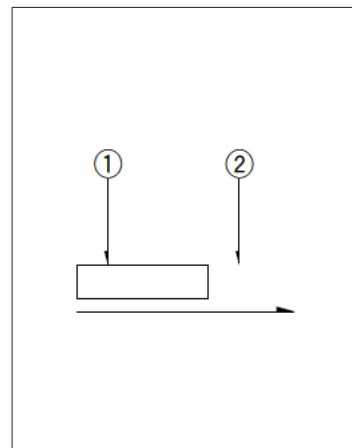

Viewed from direction A in the dimensions.

Drawing No.6

■ Dimensions

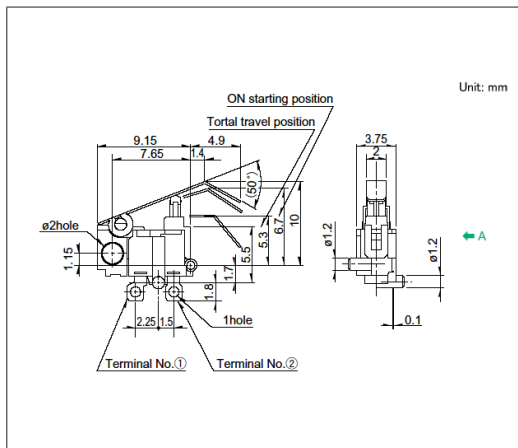

■ Mounting Hole Dimensions

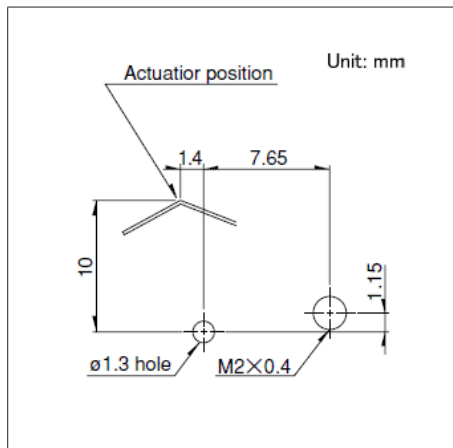

■ Circuit Diagram

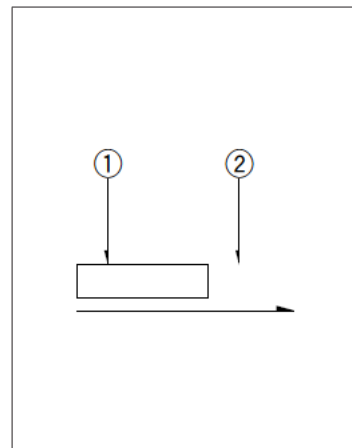

Viewed from direction A in the dimensions.

Drawing No.7

■ Dimensions

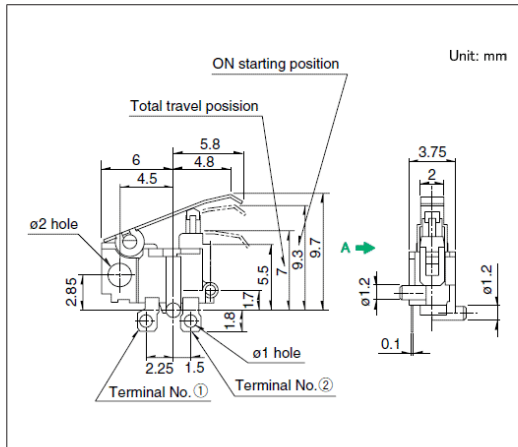

■ Mounting Hole Dimensions

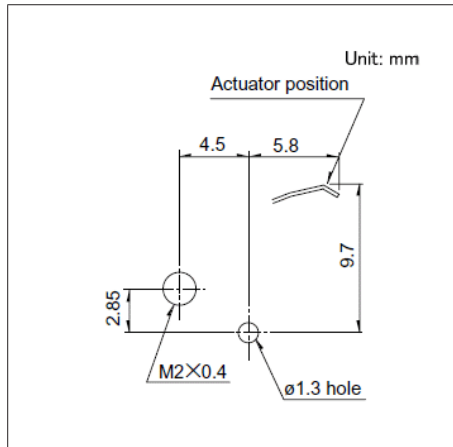

■ Circuit Diagram

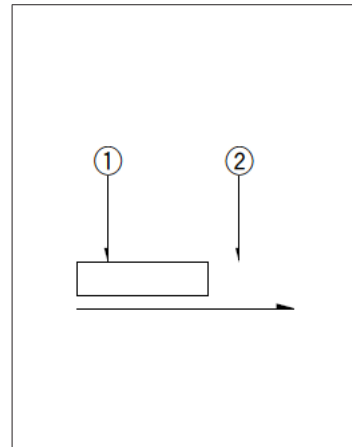

Viewed from direction A in the dimensions.

General-purpose Type
SPPB Series

Drawing No.11

■ Dimensions

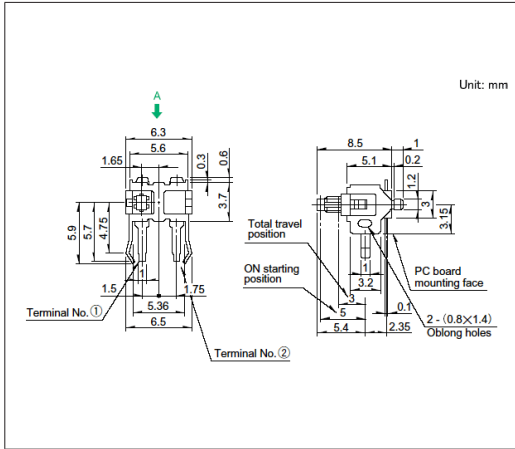

■ Mounting Hole Dimensions

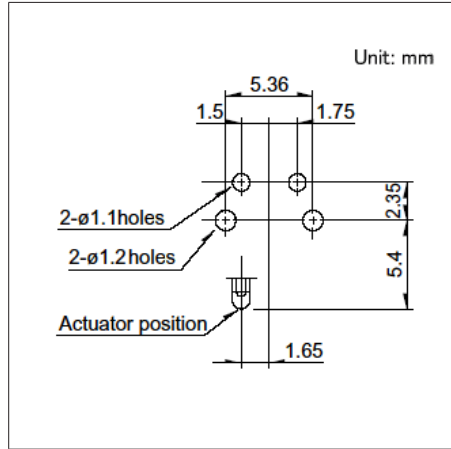

■ Circuit Diagram

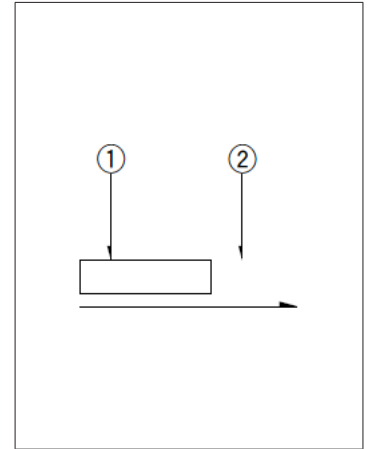

Viewed from direction A in the dimensions.

Drawing No.12

■ Dimensions

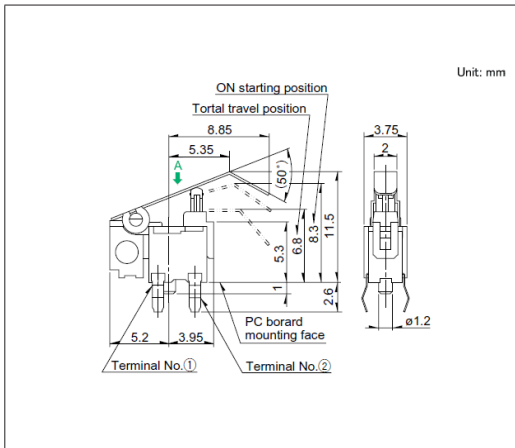

■ Mounting Hole Dimensions

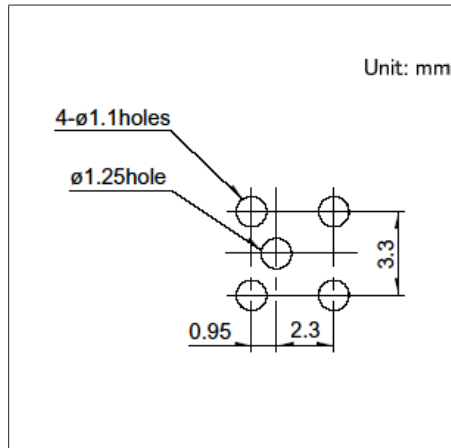

■ Circuit Diagram

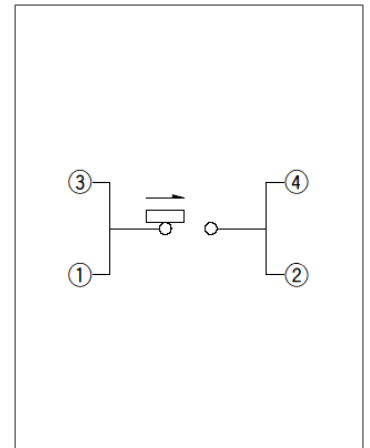

Viewed from direction A in the dimensions.

Drawing No.13

■ Dimensions

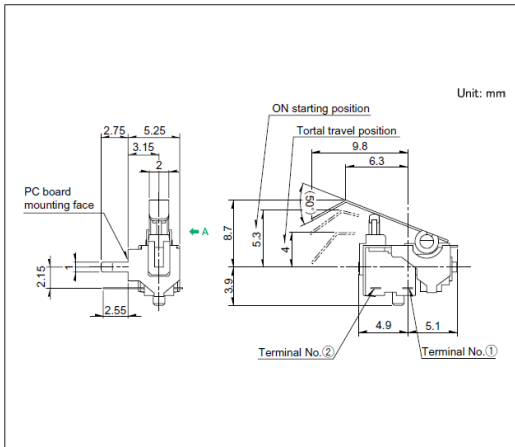

■ Mounting Hole Dimensions

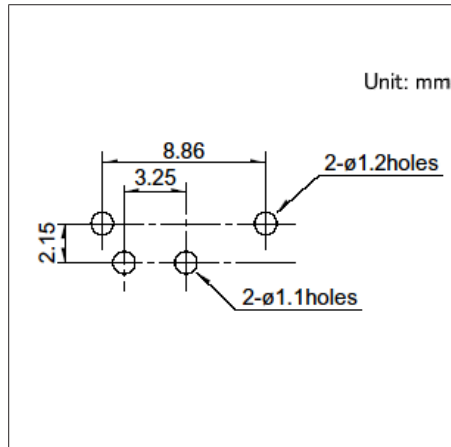

■ Circuit Diagram

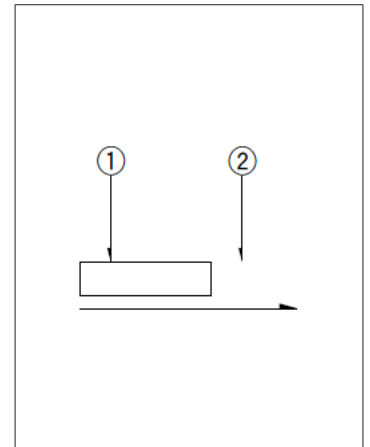

Viewed from direction A in the dimensions.

General-purpose Type
SPPB Series

Drawing No.17

■ Dimensions

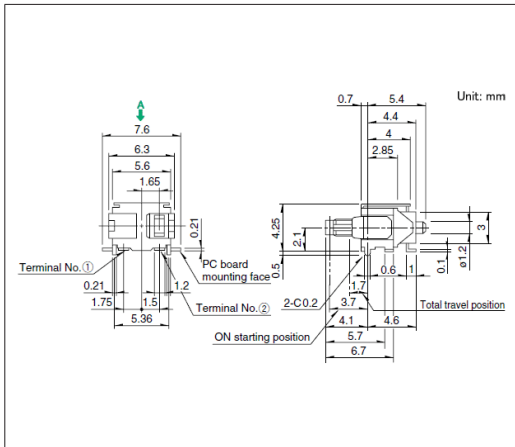

■ Land Dimensions

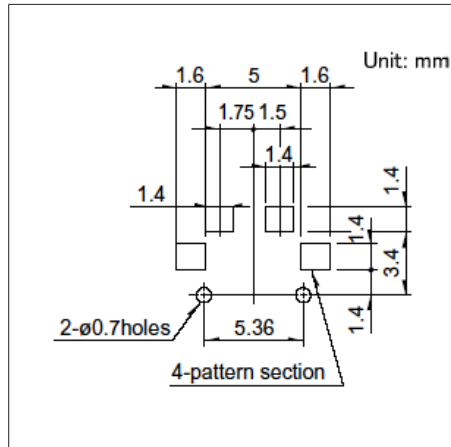

■ Circuit Diagram

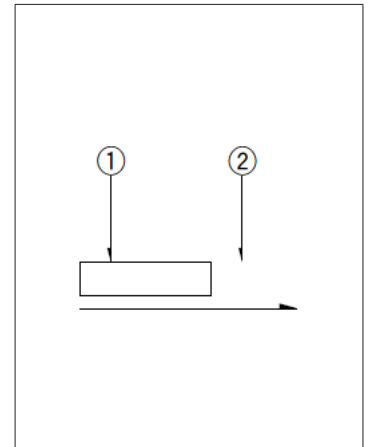

Viewed from direction A in the dimensions.

Drawing No.18

■ Dimensions

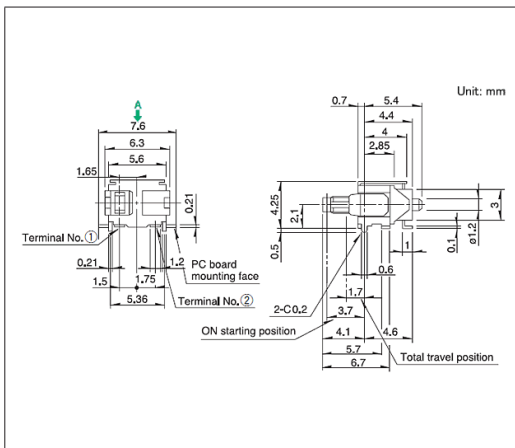

■ Land Dimensions

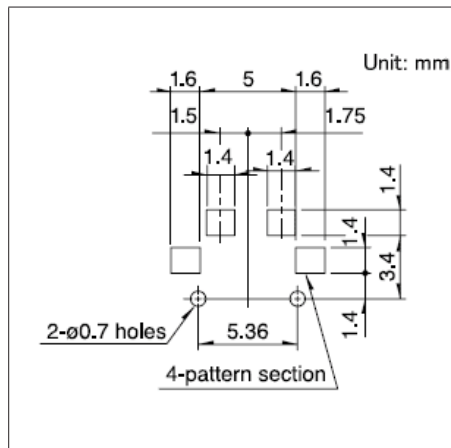

■ Circuit Diagram

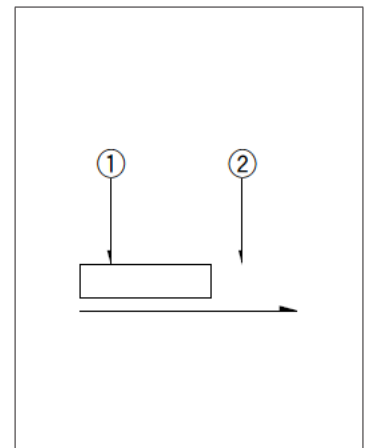

Viewed from direction A in the dimensions.

Switches **Detector Switches**

Micro Switch Type
SSCT Series

Micro switch type with printable or lead wiring, mountable on panels with screws.

Automotive

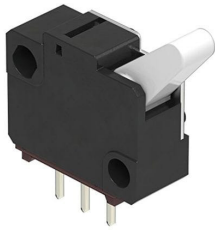

- Rating(max.)/(min.)(Resistive load):0.1A 12V DC/50μA 3V DC
- Contact resistance(Initial/After operating life):200mΩ max./500mΩ max.
- Operating life without load:10,000 cycles
- Operating life with load Rating(max.)(Resistive load):
10,000 cycles 500mΩ max.

Applications:Automotive:Hood Latch (Side/Rear/Door/Gear)

■ Product List

Products No.	Poles	Positions	Operating force	Changeover timing	Operation part shape	Terminal type	Dimensions (W×D×H) (mm)	Water-proof	Dust-proof	Automotive	Drawing No.
SSCTL10600	1	2	0.7±0.3N	Non shorting	Lever	For PC board	12.5×5.0×11.5	—	—	●	1
SSCTL10400	1	2	0.7±0.3N	Non shorting	Lever	For Lead	12.5×5.0×11.5	—	—	●	2

Note

1. This catalog shows only outline specifications. When using the products, please obtain formal specifications for supply.
2. Please place purchase orders per minimum order unit (integer).
3. This products can be used in vehicles.
Although these products are designed to perform over a wide operating temperature range, please ensure that you receive and read the formal delivery specifications before use.
4. For the Timing Lag Diagram and Terminal Style, please check our website.

■ Packing Specifications

Bulk

Number of packages (pcs.)		Export package measurements (mm)
1 case / Japan	1 case / export packing	
1,000	5,000	400 x 270 x 290

Drawing No.1

■ Dimensions

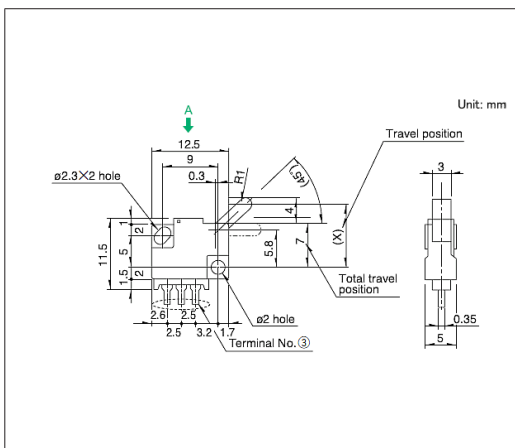

■ Mounting Hole Dimensions

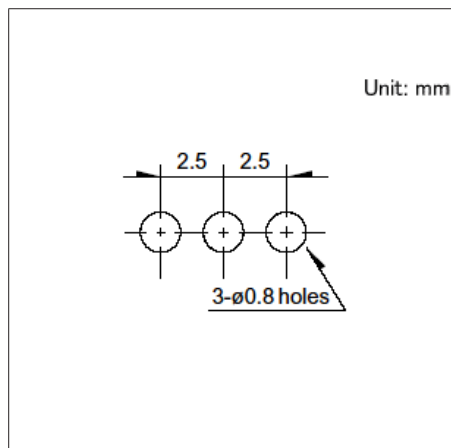

■ Circuit Diagram

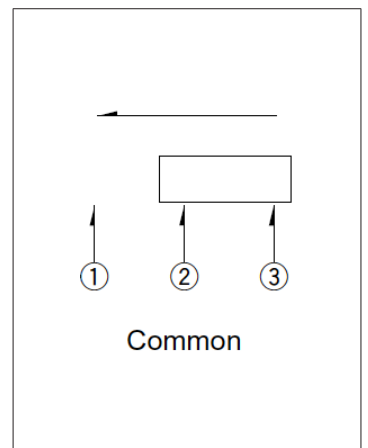

Viewed from direction A in the dimensions.

Micro Switch Type
SSCT Series

Drawing No.2

■ Dimensions

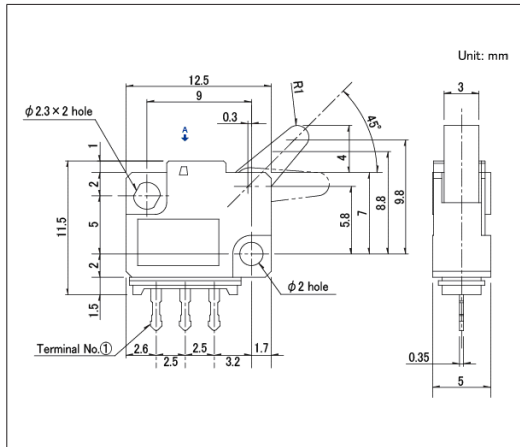

■ Circuit Diagram

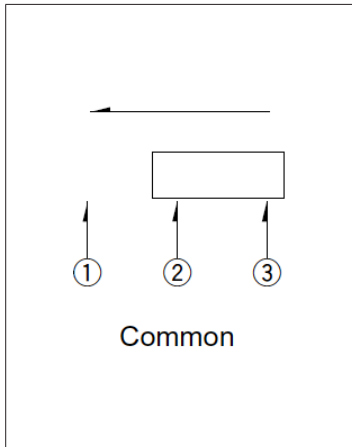

Switches **Detector Switches**

Two-way Detection
SSCF Series

Improved design freedom around set mechanisms with left-right detection capability.

Automotive

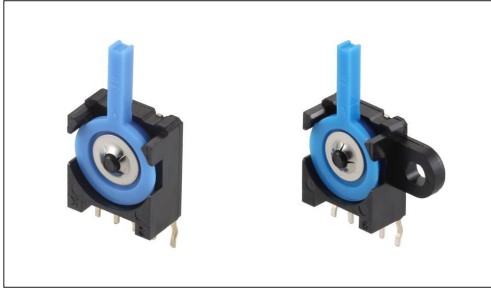

- Rating(max.)/(min.)(Resistive load):0.1A 12V DC/50μA 3V DC
- Contact resistance(Initial/After operating life): 100mΩ max./300mΩ max.
- Operating life without load:50,000 cycles
- Operating life with load Rating(max.)(Resistive load):
50,000 cycles 300mΩ max.

Applications:Audio_TV:Audio
Automotive:Hood Latch (Side/Rear/Door/Gear)

■ Product List

Products No.	Poles	Positions	Operating force	Changeover timing	Terminal type	Dimensions (W×D×H) (mm)	Water-proof	Dust-proof	Automotive	Drawing No.
SSCF110100	1	2	0.7N max.	Non shorting	For PC board	11.0×5.8×12.4	—	—	●	1
SSCF210100	1	2	0.7N max.	Non shorting	For PC board	15.5×5.8×12.4	—	—	●	2
SSCF210300	1	2	0.7N max.	Non shorting	For Lead	15.5×5.8×12.4	—	—	●	3
SSCF310100	1	2	0.7N max.	Non shorting	For PC board	11.0×5.8×12.4	—	—	●	4

Note

1. This catalog shows only outline specifications. When using the products, please obtain formal specifications for supply.
2. Please place purchase orders per minimum order unit (integer).
3. This products can be used in vehicles.
Although these products are designed to perform over a wide operating temperature range, please ensure that you receive and read the formal delivery specifications before use.
4. For the Terminal Style, please check our website.

■ Packing Specifications

Bulk

Number of packages (pcs.)		Export package measurements (mm)
1 case / Japan	1 case / export packing	
600	3,000	400 x 270 x 290

Drawing No.1

■ Dimensions

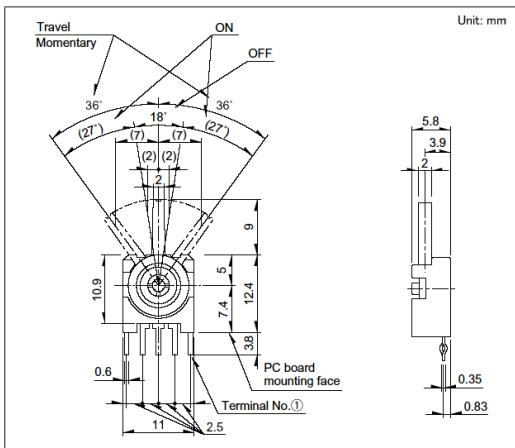

■ Mounting Hole Dimensions

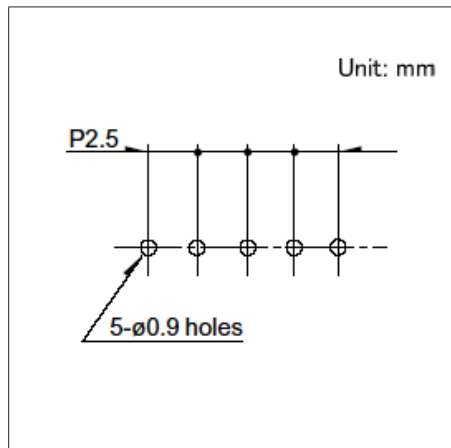

■ Circuit Diagram

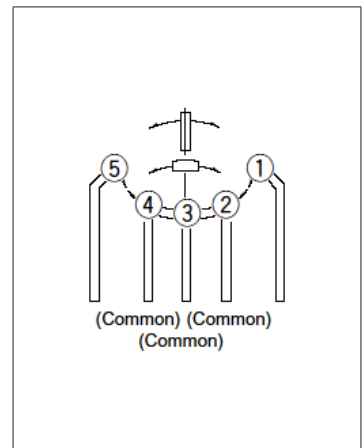

Two-way Detection
SSCF Series

Drawing No.2

■ Dimensions

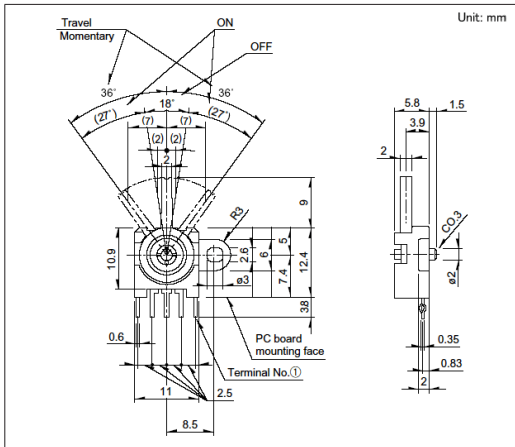

■ Circuit Diagram

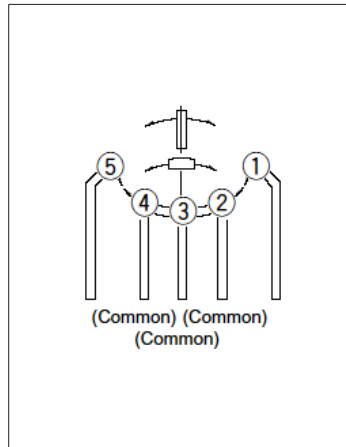

Drawing No.3

■ Dimensions

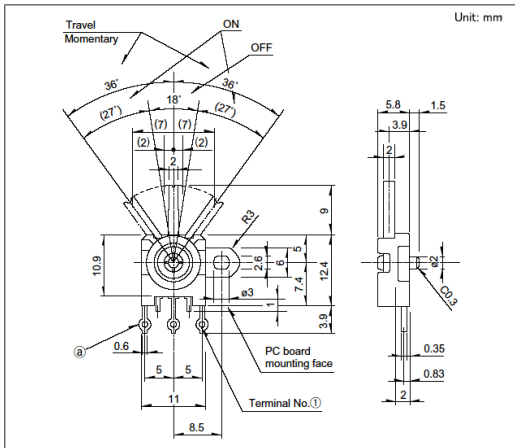

■ Circuit Diagram

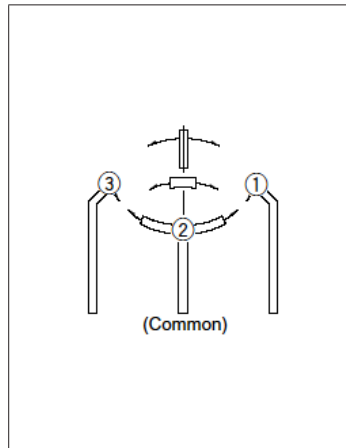

Drawing No.4

■ Dimensions

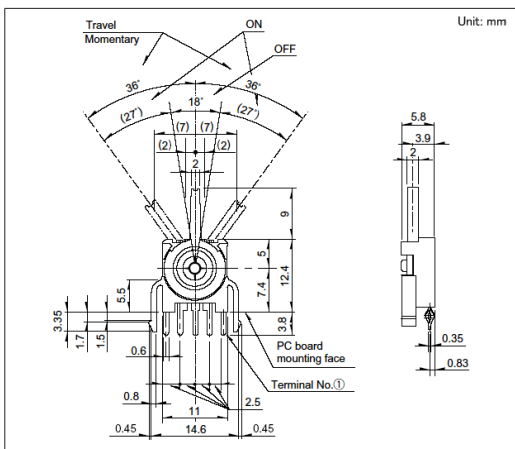

■ Mounting Hole Dimensions

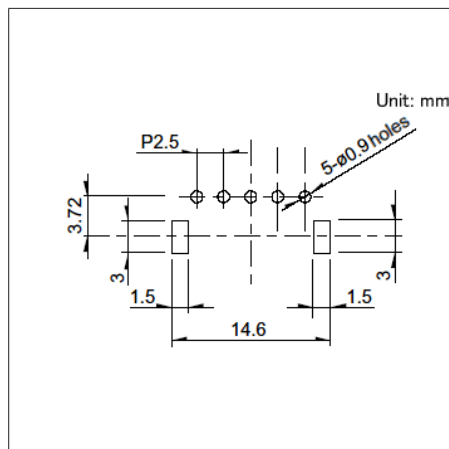

■ Circuit Diagram

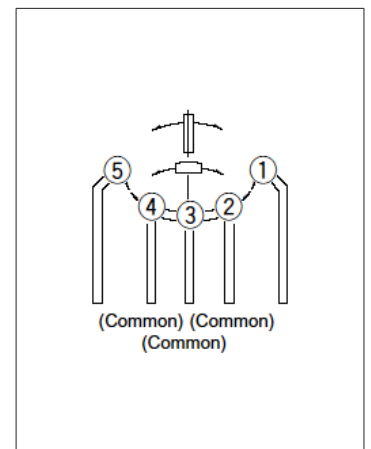

Switches **Detector Switches**

Two-way Operation with Female Connector Terminal SSCW Series

Single-circuit, single-contact design with connector connection, eliminating soldering.

Automotive



- Rating(max.)/(min.)(Resistive load):0.1A 12V DC/100μA 3V DC
- Contact resistance(Initial/After operating life):500mΩ max./1Ω max.
- Operating life without load:100,000 cycles
- Operating life with load Rating(max.)(Resistive load):
100,000 cycles 1Ω max.

Applications:Energy_Industrial:Robots, drones,Industrial equipment
Home:Major home appliances
Automotive:Hood Latch (Side/Rear/Door/Gear)

■ Product List

Products No.	Poles	Positions	Operating force	Terminal type	Dimensions (W×D×H) (mm)	Water-proof	Dust-proof	Automotive	Drawing No.
SSCW110102	1	1	1N max.	Female connector type	5.3×13.1×11.35	—	—	●	1

Note

1. This catalog shows only outline specifications. When using the products, please obtain formal specifications for supply.
2. Please place purchase orders per minimum order unit (integer).
3. This products can be used in vehicles.
Although these products are designed to perform over a wide operating temperature range, please ensure that you receive and read the formal delivery specifications before use.

■ Packing Specifications

Bulk

Number of packages (pcs.)		Export package measurements (mm)
1 case / Japan	1 case / export packing	
2,000	10,000	389 x 276 x 380

Drawing No.1

■ Dimensions

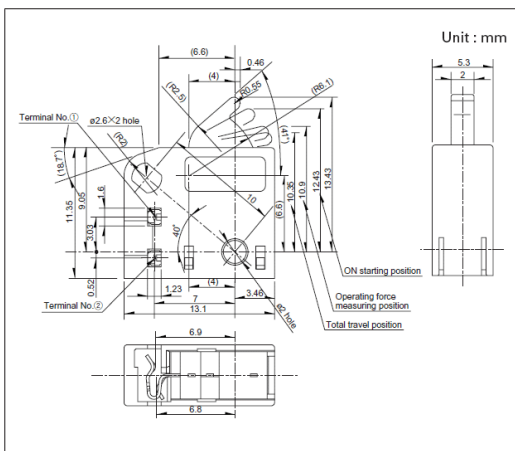

■ Recommended Unit Terminal style

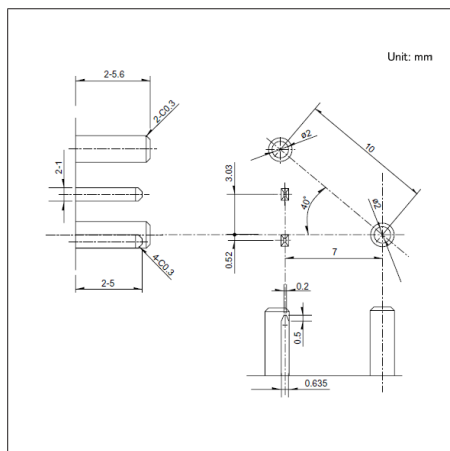

■ Circuit Diagram

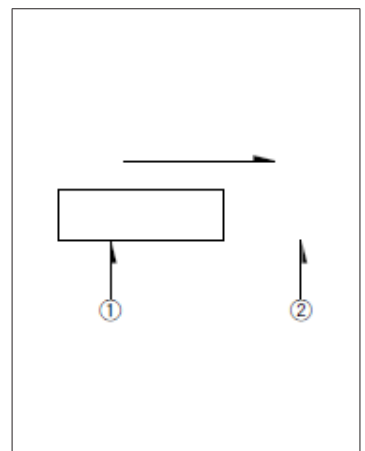

Switches **Detector Switches**

Two-way Detection with Female Connector Terminal
SSCL Series

One-touch connection with female connector terminals, achieving solderless assembly.

Automotive



- Rating(max.)/(min.)(Resistive load):0.1A 12V DC/50μA 5V DC
- Contact resistance(Initial/After operating life):500mΩ max./1Ω max.
- Operating life without load:50,000 cycles
- Operating life with load Rating(max.)(Resistive load):
50,000 cycles 1Ω max.

Applications:Automotive:Hood Latch (Side/Rear/Door/Gear)

■ Product List

Products No.	Poles	Positions	Operating force	Terminal type	Dimensions (W×D×H) (mm)	Water-proof	Dust-proof	Automotive	Drawing No.
SSCL110101	1	2	0.7N max.	Female connector type	5.3×11.0×16.1	—	—	●	1

Note

1. This catalog shows only outline specifications. When using the products, please obtain formal specifications for supply.
2. Please place purchase orders per minimum order unit (integer).
3. This products can be used in vehicles.
Although these products are designed to perform over a wide operating temperature range, please ensure that you receive and read the formal delivery specifications before use.

■ Packing Specifications

Bulk

Number of packages(pcs.)		Export package measurements (mm)
1 case / Japan	1 case / export packing	
1,000	5,000	400 x 270 x 290

Drawing No.1

■ Dimensions

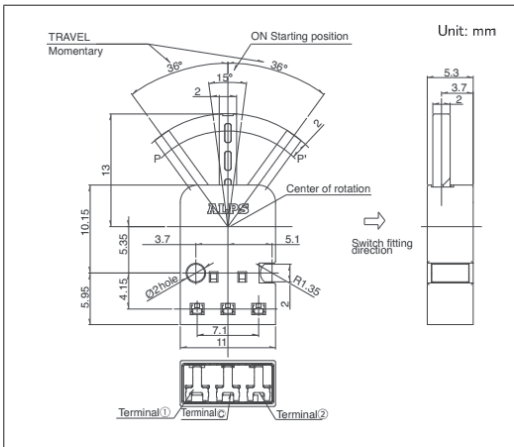

■ Recommended Unit Terminal style

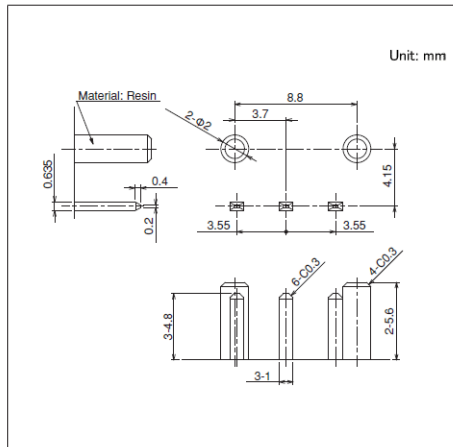

■ Circuit Diagram

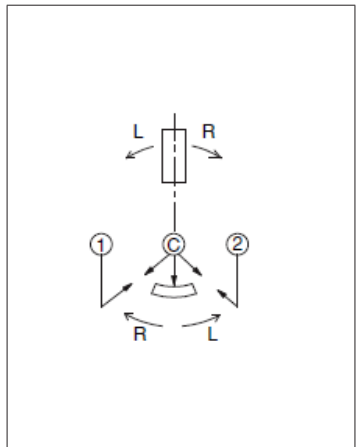

Switches **Detector Switches**

With Connector Terminal Two-way Operation
SSCZ Series

Connector connection eliminates the need for soldering.

Automotive



- Rating(max.)/(min.)(Resistive load):0.1A 16V DC/100μA 3V DC
- Contact resistance(Initial/After operating life):500mΩ max./1Ω max.
- Operating life without load:300,000 cycles
- Operating life with load Rating(max.)(Resistive load):
300,000 cycles 1Ω max.

Applications:Automotive:Hood Latch (Side/Rear/Door/Gear)

■ Product List

Products No.	Poles	Positions	Operating force	Terminal type	Dimensions (W×D×H) (mm)	Water-proof	Dust-proof	Automotive	Drawing No.
SSCZ110101	1	2	1.1N max.	Connector type	13.84×5.4×15.4	—	—	●	1

Note

1. This catalog shows only outline specifications. When using the products, please obtain formal specifications for supply.
2. Please place purchase orders per minimum order unit (integer).
3. This products can be used in vehicles.
 Although these products are designed to perform over a wide operating temperature range, please ensure that you receive and read the formal delivery specifications before use.

■ Packing Specifications

Bulk

Number of packages(pcs.)		Export package measurements (mm)
1 case / Japan	1 case / export packing	
1,200	6,000	389 x 276 x 380

Drawing No.1

■ Dimensions

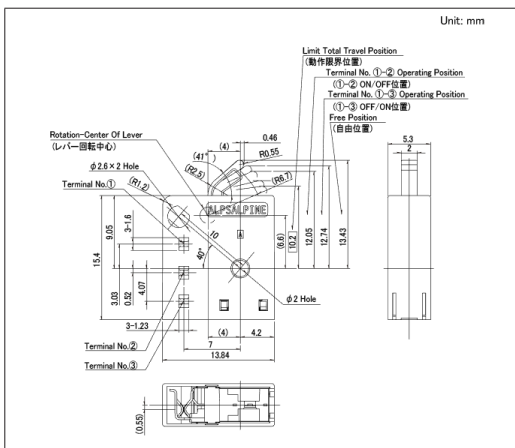

■ Recommended Unit Terminal style

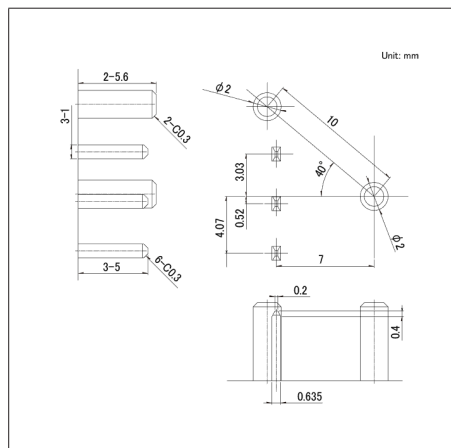

■ Circuit Diagram

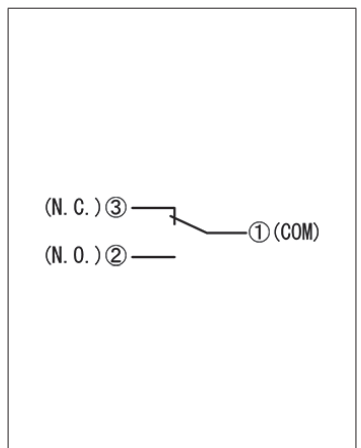

Water-proof Type SPVQ3 Series

Wide product variety including long-stroke types pressable diagonally without an actuator.



Automotive

Water-proof Type

Dust-proof Type

- Rating(max.)/(min.)(Resistive load):0.1A 12V DC/50 μ A 5V DC
- Contact resistance(Initial/After operating life):500m Ω max./1 Ω max.
- Operating life without load:300,000 cycles
- Operating life with load Rating(max.)(Resistive load):
300,000 cycles 1 Ω max.

Applications:Energy_Industrial:Robots, drones,Industrial equipment
Home:Major home appliances
Automotive:Hood Latch (Side/Rear/Door/Gear)

Product List

Products No.	Poles	Positions	Operating force	Changeover timing	Operation part shape	Terminal type	Main body form	Dimensions (W×D×H) (mm)	Water-proof	Dust-proof	Automotive	Drawing No.
SPVQ380400	1	2	1±0.5N	Non shorting	Push	For PC board	Without boss	5.3×13.0×8.35	●	●	●	1
SPVQ380300	1	2	1±0.5N	Non shorting	Push	For PC board	Boss - right side	5.3×13.0×8.35	●	●	●	2
SPVQ380201	1	2	1±0.5N	Non shorting	Push	For PC board	Boss - left side	5.3×13.0×8.35	●	●	●	3
SPVQ380100	1	2	1±0.5N	Non shorting	Push	For PC board	Boss - both sides	5.3×13.0×8.35	●	●	●	4
SPVQ380700	1	2	1±0.5N	Non shorting	Push	For Lead	Boss - right side	5.3×13.0×8.35	●	●	●	5
SPVQ380600	1	2	1±0.5N	Non shorting	Push	For Lead	Boss - left side	5.3×13.0×8.35	●	●	●	6
SPVQ380500	1	2	1±0.5N	Non shorting	Push	For Lead	Boss - both sides	5.3×13.0×8.35	●	●	●	7
SPVQ380900	1	2	1±0.5N	Non shorting	Push	Angle (Right)	Boss - right side	5.3×13.0×8.35	●	●	●	8
SPVQ380800	1	2	1±0.5N	Non shorting	Push	Angle (Left)	Boss - left side	5.3×13.0×8.35	●	●	●	9
SPVQ361000	1	2	1±0.5N	Non shorting	Push	With wire (Downwards)	With a screw hole	5.3×13.0×8.35	●	●	●	10
SPVQ361100	1	2	1±0.5N	Non shorting	Push	With wire (Downwards)	Boss - right side	5.3×13.0×8.35	●	●	●	11
SPVQ361200	1	2	1±0.5N	Non shorting	Push	With wire (Downwards)	Boss - left side	5.3×13.0×8.35	●	●	●	12
SPVQ361300	1	2	1±0.5N	Non shorting	Push	With wire (Downwards)	Boss - both sides	5.3×13.0×8.35	●	●	●	13
SPVQ361400	1	1	1±0.5N	Non shorting	Push	With wire (Right side)	With a screw hole	5.3×13.0×8.35	●	●	●	14
SPVQ361500	1	1	1±0.5N	Non shorting	Push	With wire (Right side)	Boss - right side	5.3×13.0×8.35	●	●	●	15
SPVQ361600	1	1	1±0.5N	Non shorting	Push	With wire (Right side)	Boss - left side	5.3×13.0×8.35	●	●	●	16
SPVQ361700	1	1	1±0.5N	Non shorting	Push	With wire (Right side)	Boss - both sides	5.3×13.0×8.35	●	●	●	17
SPVQ361800	1	1	1±0.5N	Non shorting	Push	With wire (Left side)	Boss - right side	5.3×13.0×8.35	●	●	●	18
SPVQ361900	1	1	1±0.5N	Non shorting	Push	With wire (Left side)	Boss - left side	5.3×13.0×8.35	●	●	●	19
SPVQ362000	1	1	1±0.5N	Non shorting	Push	With wire (Left side)	Boss - both sides	5.3×13.0×8.35	●	●	●	20
SPVQ370400	1	2	3N max.	Non shorting	Actuator A	For PC board	Without boss	5.3×13.0×8.35	●	●	●	21
SPVQ370300	1	2	3N max.	Non shorting	Actuator A	For PC board	Boss - right side	5.3×13.0×8.35	●	●	●	22
SPVQ370200	1	2	3N max.	Non shorting	Actuator A	For PC board	Boss - left side	5.3×13.0×8.35	●	●	●	23
SPVQ370100	1	2	3N max.	Non shorting	Actuator A	For PC board	Boss - both sides	5.3×13.0×8.35	●	●	●	24

Switches

Detector Switches

Water-proof Type
SPVQ3 Series

Products No.	Poles	Positions	Operating force	Changeover timing	Operation part shape	Terminal type	Main body form	Dimensions (W×D×H) (mm)	Water-proof	Dust-proof	Automotive	Drawing No.
SPVQ370700	1	2	3N max.	Non shorting	Actuator A	For Lead	Boss - right side	5.3×13.0×8.35	●	●	●	25
SPVQ370600	1	2	3N max.	Non shorting	Actuator A	For Lead	Boss - left side	5.3×13.0×8.35	●	●	●	26
SPVQ370500	1	2	3N max.	Non shorting	Actuator A	For Lead	Boss - both sides	5.3×13.0×8.35	●	●	●	27
SPVQ370900	1	2	3N max.	Non shorting	Actuator A	Angle (Right)	Boss - right side	5.3×13.0×8.35	●	●	●	28
SPVQ370800	1	2	3N max.	Non shorting	Actuator A	Angle (Left)	Boss - left side	5.3×13.0×8.35	●	●	●	29
SPVQ350100	1	2	3N max.	Non shorting	Actuator A	With wire (Downwards)	With a screw hole	5.3×13.0×8.35	●	●	●	30
SPVQ350200	1	2	3N max.	Non shorting	Actuator A	With wire (Downwards)	Boss - right side	5.3×13.0×8.35	●	●	●	31
SPVQ350300	1	2	3N max.	Non shorting	Actuator A	With wire (Downwards)	Boss - left side	5.3×13.0×8.35	●	●	●	32
SPVQ350400	1	2	3N max.	Non shorting	Actuator A	With wire (Downwards)	Boss - both sides	5.3×13.0×8.35	●	●	●	33
SPVQ350600	1	1	3N max.	Non shorting	Actuator A	With wire (Right side)	Boss - right side	5.3×13.0×8.35	●	●	●	34
SPVQ350700	1	1	3N max.	Non shorting	Actuator A	With wire (Right side)	Boss - left side	5.3×13.0×8.35	●	●	●	35
SPVQ350800	1	1	3N max.	Non shorting	Actuator A	With wire (Right side)	Boss - both sides	5.3×13.0×8.35	●	●	●	36
SPVQ350900	1	1	3N max.	Non shorting	Actuator A	With wire (Left side)	Boss - right side	5.3×13.0×8.35	●	●	●	37
SPVQ351000	1	1	3N max.	Non shorting	Actuator A	With wire (Left side)	Boss - left side	5.3×13.0×8.35	●	●	●	38
SPVQ351100	1	1	3N max.	Non shorting	Actuator A	With wire (Left side)	Boss - both sides	5.3×13.0×8.35	●	●	●	39
SPVQ371300	1	2	3N max.	Non shorting	Actuator B	For PC board	Without boss	5.3×13.0×8.35	●	●	●	40
SPVQ371200	1	2	3N max.	Non shorting	Actuator B	For PC board	Boss - right side	5.3×13.0×8.35	●	●	●	41
SPVQ371100	1	2	3N max.	Non shorting	Actuator B	For PC board	Boss - left side	5.3×13.0×8.35	●	●	●	42
SPVQ371000	1	2	3N max.	Non shorting	Actuator B	For PC board	Boss - both sides	5.3×13.0×8.35	●	●	●	43
SPVQ371600	1	2	3N max.	Non shorting	Actuator B	For Lead	Boss - right side	5.3×13.0×8.35	●	●	●	44
SPVQ371500	1	2	3N max.	Non shorting	Actuator B	For Lead	Boss - left side	5.3×13.0×8.35	●	●	●	45
SPVQ371400	1	2	3N max.	Non shorting	Actuator B	For Lead	Boss - both sides	5.3×13.0×8.35	●	●	●	46
SPVQ371800	1	2	3N max.	Non shorting	Actuator B	Angle (Right)	Boss - right side	5.3×13.0×8.35	●	●	●	47
SPVQ371700	1	2	3N max.	Non shorting	Actuator B	Angle (Left)	Boss - left side	5.3×13.0×8.35	●	●	●	48
SPVQ351200	1	2	3N max.	Non shorting	Actuator B	With wire (Downwards)	With a screw hole	5.3×13.0×8.35	●	●	●	49
SPVQ351300	1	2	3N max.	Non shorting	Actuator B	With wire (Downwards)	Boss - right side	5.3×13.0×8.35	●	●	●	50
SPVQ351400	1	2	3N max.	Non shorting	Actuator B	With wire (Downwards)	Boss - left side	5.3×13.0×8.35	●	●	●	51
SPVQ351500	1	2	3N max.	Non shorting	Actuator B	With wire (Downwards)	Boss - both sides	5.3×13.0×8.35	●	●	●	52
SPVQ351700	1	1	3N max.	Non shorting	Actuator B	With wire (Right side)	Boss - right side	5.3×13.0×8.35	●	●	●	53
SPVQ351800	1	1	3N max.	Non shorting	Actuator B	With wire (Right side)	Boss - left side	5.3×13.0×8.35	●	●	●	54
SPVQ351900	1	1	3N max.	Non shorting	Actuator B	With wire (Right side)	Boss - both sides	5.3×13.0×8.35	●	●	●	55
SPVQ352000	1	1	3N max.	Non shorting	Actuator B	With wire (Left side)	Boss - right side	5.3×13.0×8.35	●	●	●	56
SPVQ352100	1	1	3N max.	Non shorting	Actuator B	With wire (Left side)	Boss - left side	5.3×13.0×8.35	●	●	●	57
SPVQ352200	1	1	3N max.	Non shorting	Actuator B	With wire (Left side)	Boss - both sides	5.3×13.0×8.35	●	●	●	58

**Water-proof Type
SPVQ3 Series**
 **Note**

1. This catalog shows only outline specifications. When using the products, please obtain formal specifications for supply.
2. Unless specified, the length of the lead wire is 250mm. Color is either Red, Black or Yellow. For length modification, please contact us.
3. This unit cannot be used in water (IP6K7 rating, except for terminal).
4. Unless circuit is specified, wired (downward) types will apply three wires.
5. Please specify circuit (N. O. or N. C.) for wired (side) types. Unless specified, the circuit will apply N. O.
6. Please place purchase orders per minimum order unit (integer).
7. This products can be used in vehicles.
Although these products are designed to perform over a wide operating temperature range, please ensure that you receive and read the formal delivery specifications before use.

■ Packing Specifications
Tray

Products No.	Number of packages(pcs.)		Export package measurements (mm)
	1 case / Japan	1 case / export packing	
SPVQ380400 SPVQ380300 SPVQ380201 SPVQ380100 SPVQ380700 SPVQ380600 SPVQ380500 SPVQ380900 SPVQ380800 SPVQ370400 SPVQ370300 SPVQ370200 SPVQ370100 SPVQ370700 SPVQ370600 SPVQ370500 SPVQ370900 SPVQ370800 SPVQ371300 SPVQ371200 SPVQ371100 SPVQ371000 SPVQ371600 SPVQ371500 SPVQ371400 SPVQ371800 SPVQ371700	1,300	5,200	540 x 360 x 290

Bulk

Products No.	Number of packages(pcs.)		Export package measurements (mm)
	1 case / Japan	1 case / export packing	
SPVQ361000 SPVQ361100 SPVQ361200 SPVQ361300 SPVQ361400 SPVQ361500 SPVQ361600 SPVQ361700 SPVQ361800 SPVQ361900 SPVQ362000	400	1,600	555 x 375 x 223
SPVQ350100 SPVQ350200 SPVQ350300 SPVQ350400 SPVQ351200 SPVQ351300 SPVQ351400 SPVQ351500	180	720	540 x 360 x 270
SPVQ350600 SPVQ350700 SPVQ350800 SPVQ350900 SPVQ351000 SPVQ351100 SPVQ351700 SPVQ351800 SPVQ351900 SPVQ352000 SPVQ352100 SPVQ352200	168	672	555 x 375 x 223

Water-proof Type
SPVQ3 Series

Drawing No.1

■ Dimensions

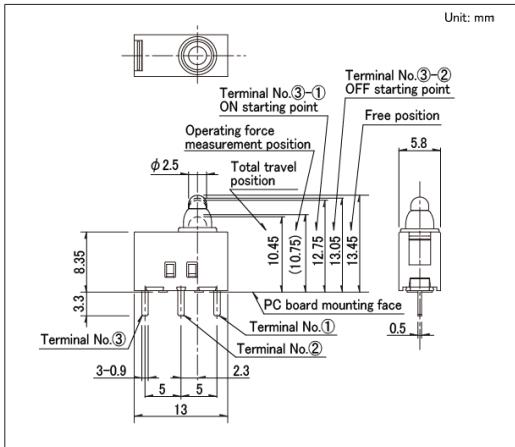

■ Circuit Diagram

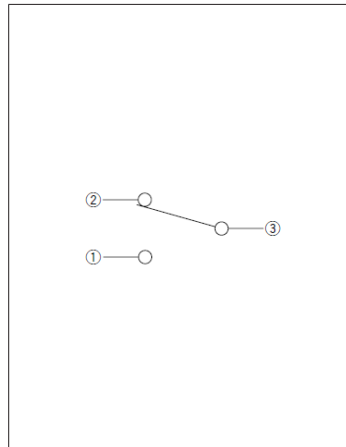

Drawing No.2

■ Dimensions

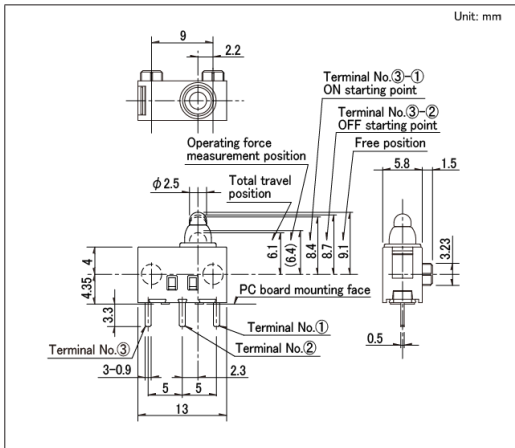

■ Circuit Diagram

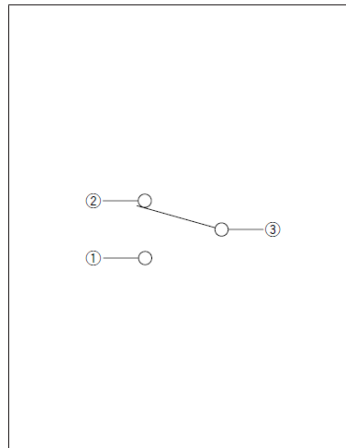

Drawing No.3

■ Dimensions

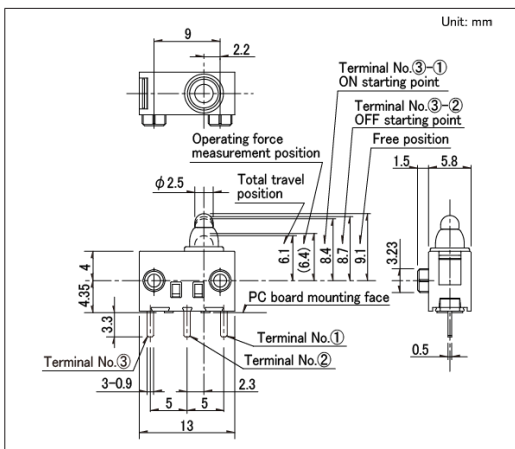

■ Circuit Diagram

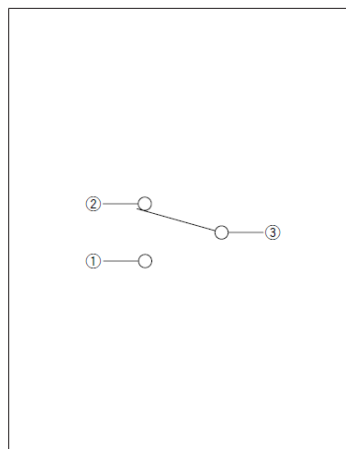

Water-proof Type
SPVQ3 Series

Drawing No.4

■ Dimensions

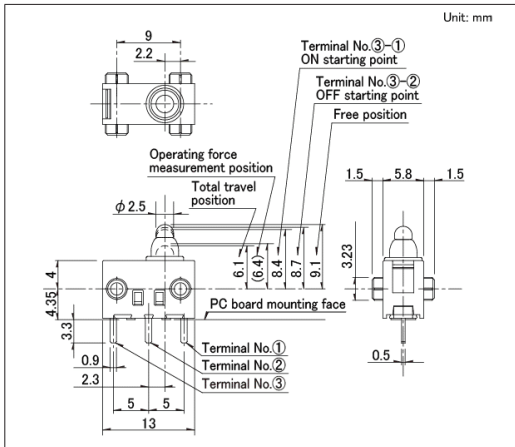

■ Circuit Diagram

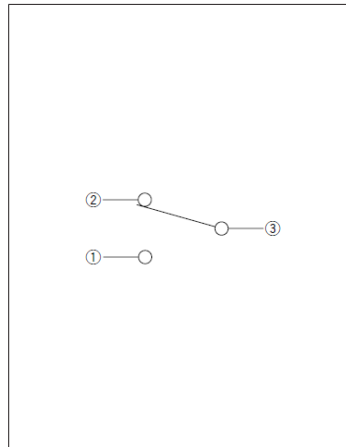

Drawing No.5

■ Dimensions

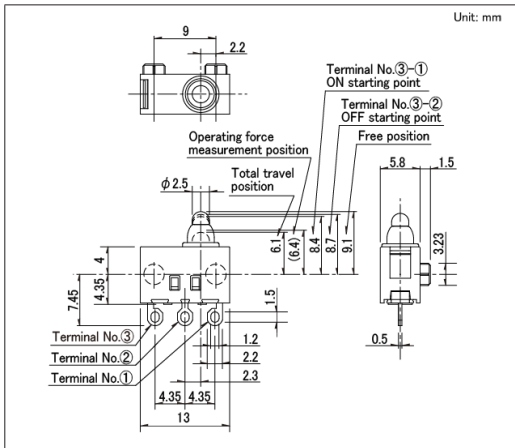

■ Circuit Diagram

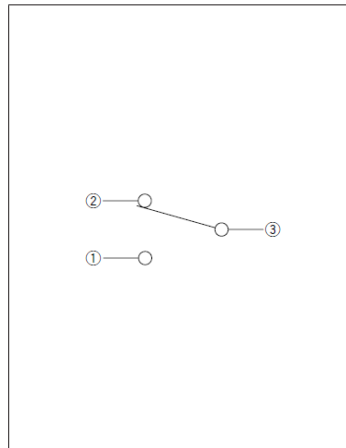

Drawing No.6

■ Dimensions

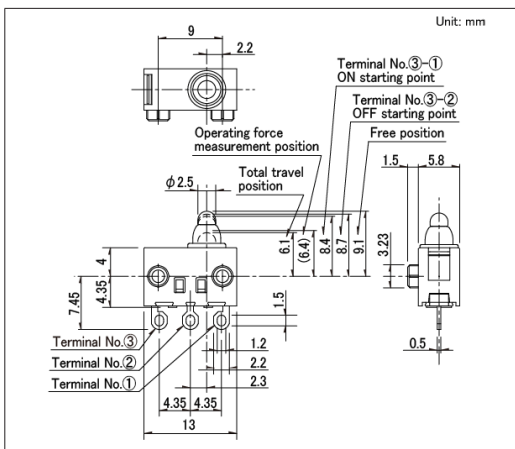

■ Circuit Diagram

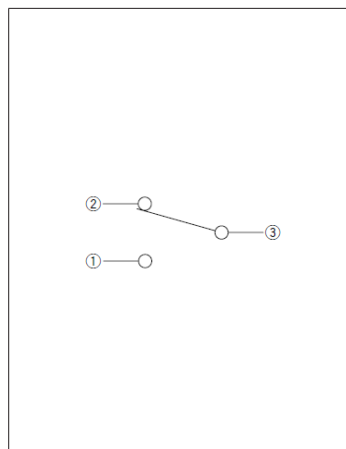

Water-proof Type
SPVQ3 Series

Drawing No.7

■ Dimensions

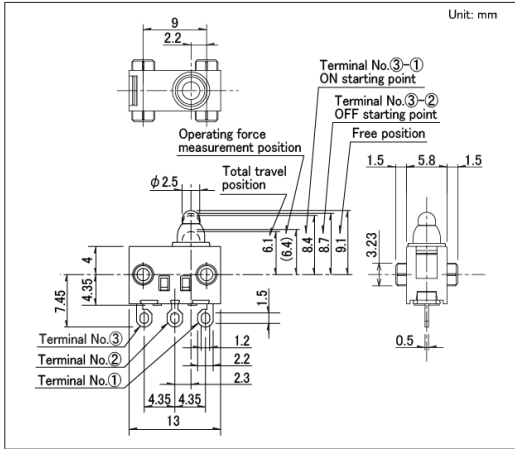

■ Circuit Diagram

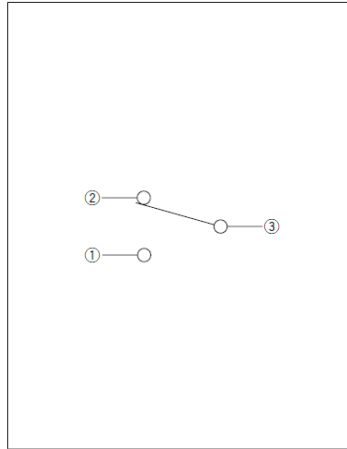

Drawing No.8

■ Dimensions

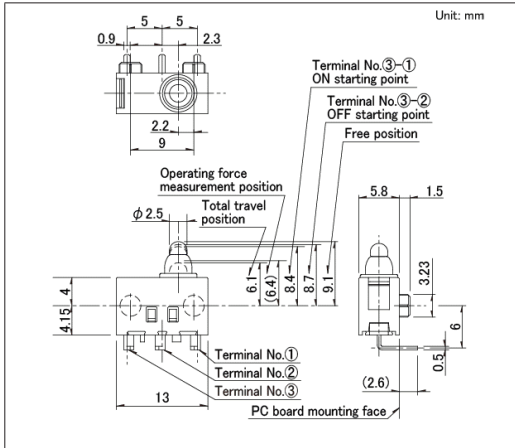

■ Circuit Diagram

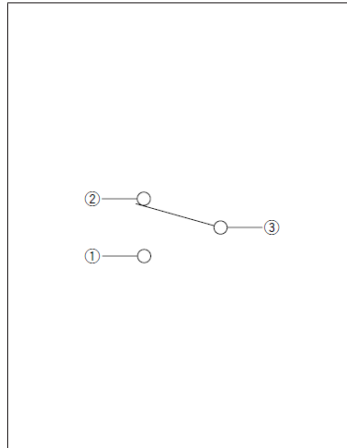

Drawing No.9

■ Dimensions

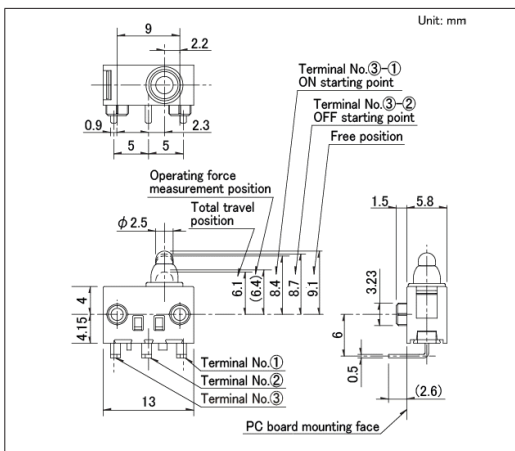

■ Circuit Diagram

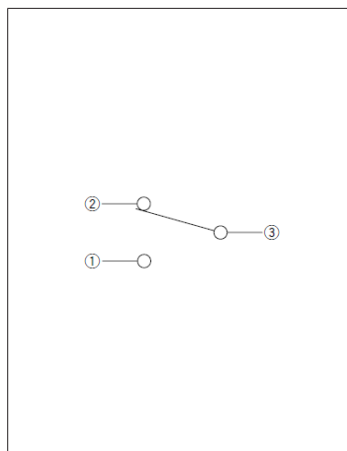

Water-proof Type
SPVQ3 Series

Drawing No.10

■ Dimensions

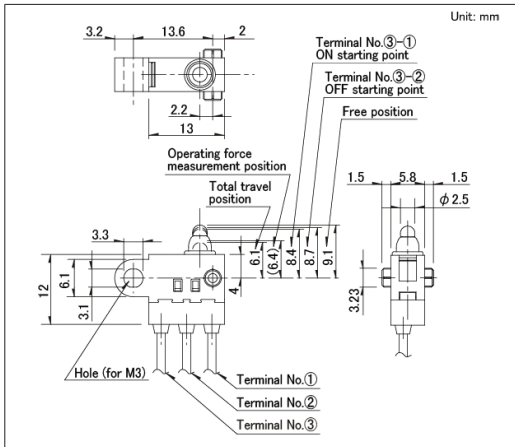

■ Circuit Diagram

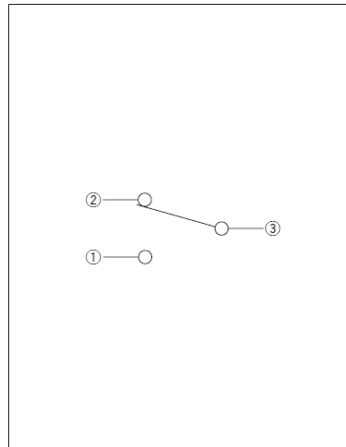

Drawing No.11

■ Dimensions

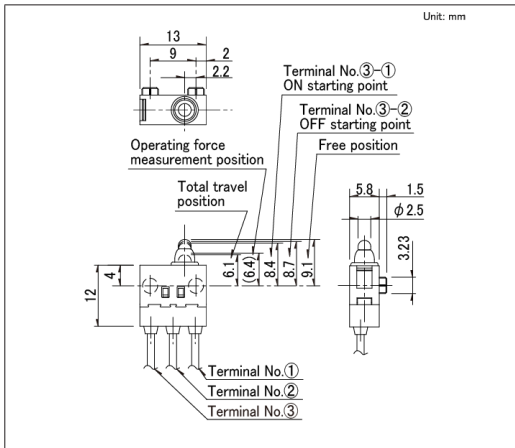

■ Circuit Diagram

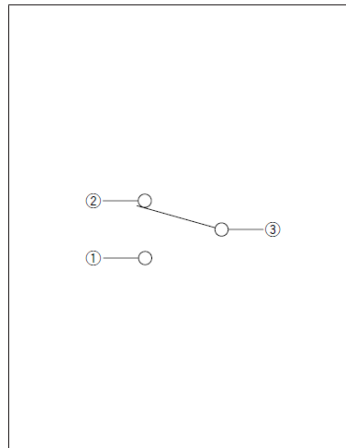

Drawing No.12

■ Dimensions

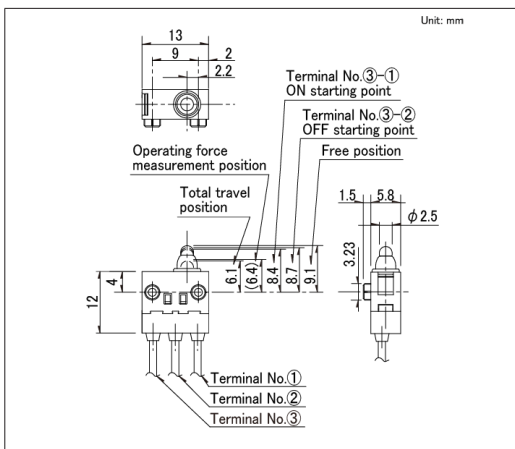

■ Circuit Diagram

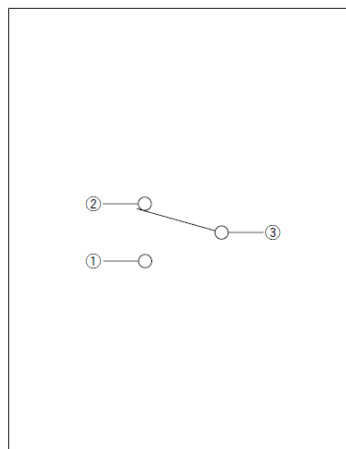

Water-proof Type
SPVQ3 Series

Drawing No.13

■ Dimensions

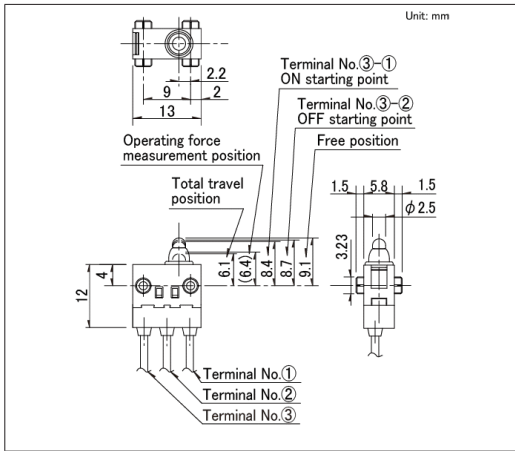

■ Circuit Diagram

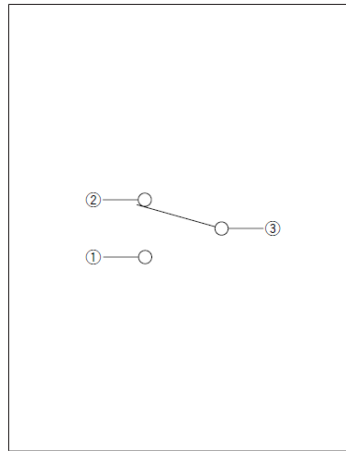

Drawing No.14

■ Dimensions

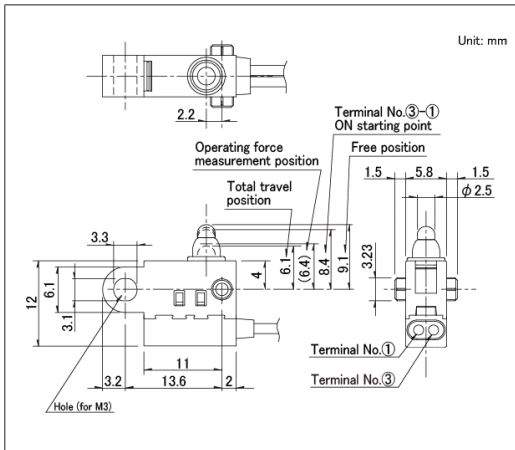

■ Circuit Diagram

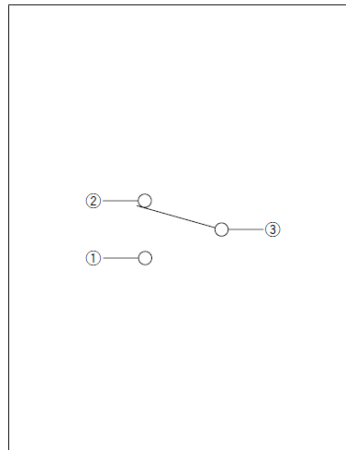

Drawing No.15

■ Dimensions

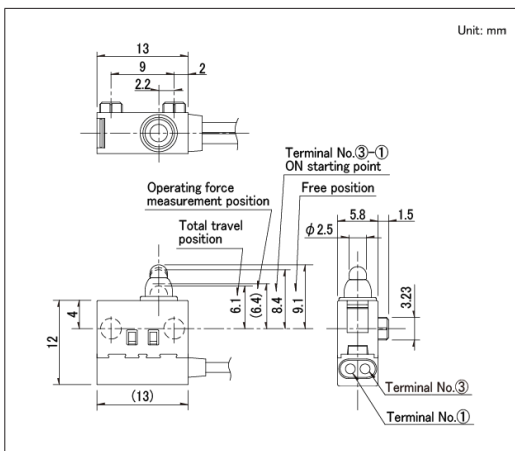

■ Circuit Diagram

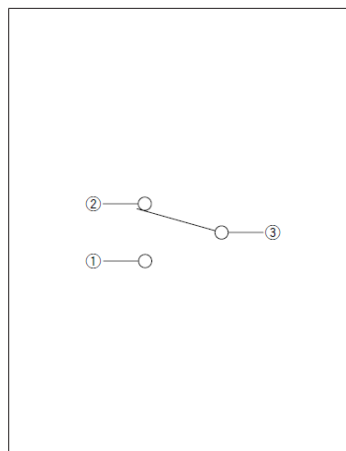

Water-proof Type
SPVQ3 Series

Drawing No.16

■ Dimensions

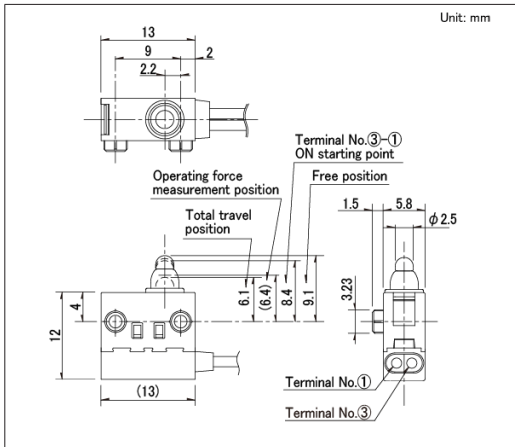

■ Circuit Diagram

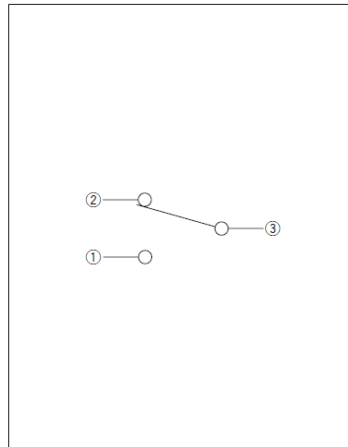

Drawing No.17

■ Dimensions

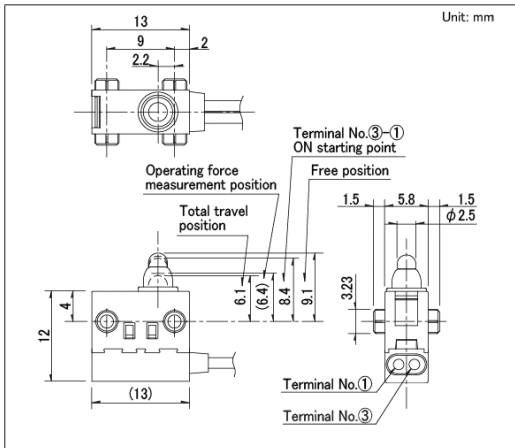

■ Circuit Diagram

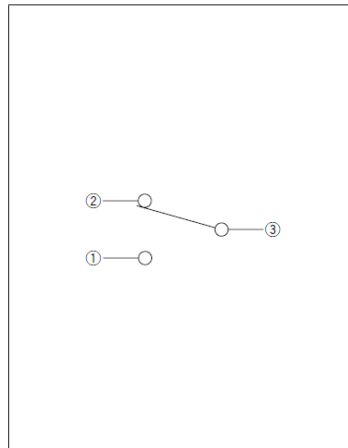

Drawing No.18

■ Dimensions

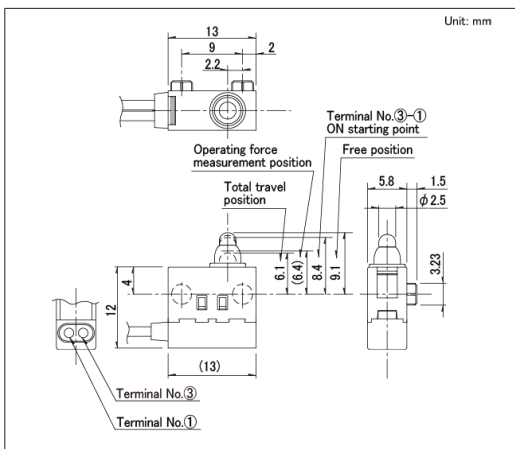

■ Circuit Diagram

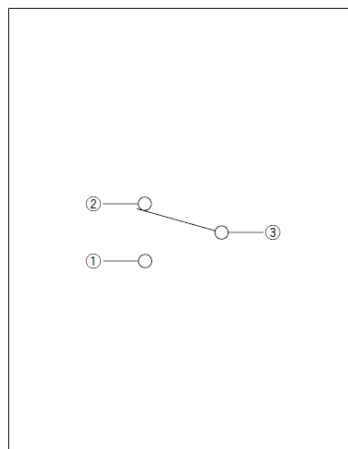

Water-proof Type
SPVQ3 Series

Drawing No.19

■ Dimensions

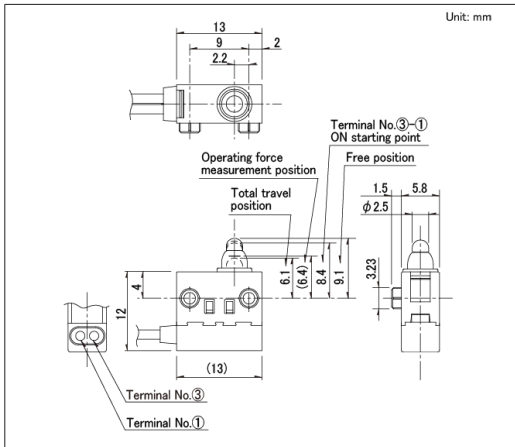

■ Circuit Diagram

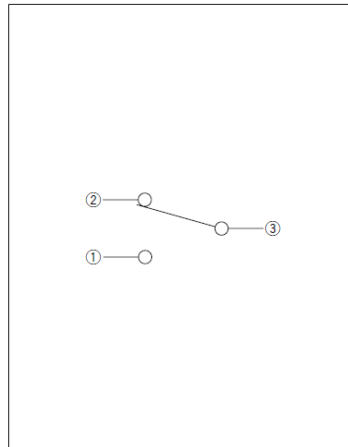

Drawing No.20

■ Dimensions

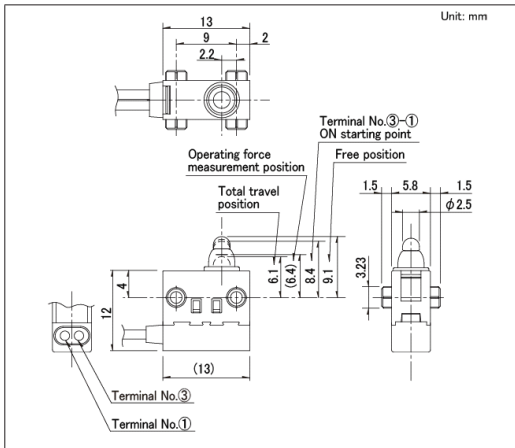

■ Circuit Diagram

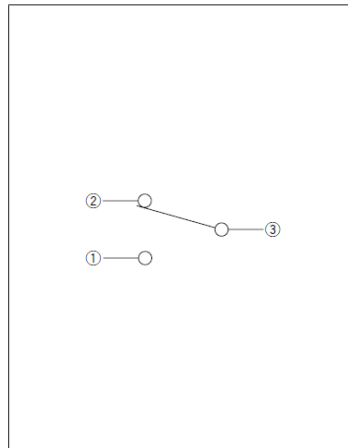

Drawing No.21

■ Dimensions

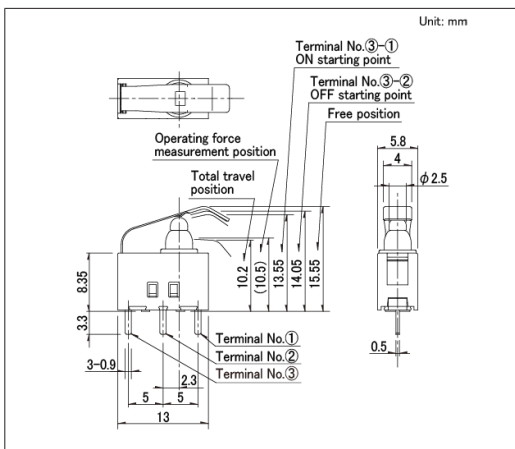

■ Circuit Diagram

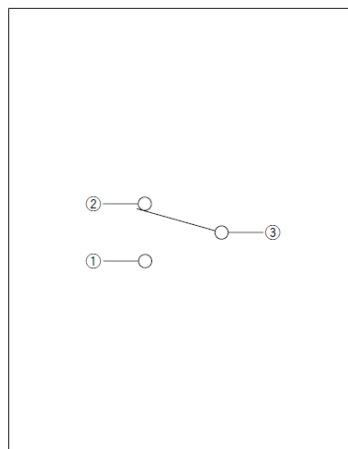

Water-proof Type
SPVQ3 Series

Drawing No.22

■ Dimensions

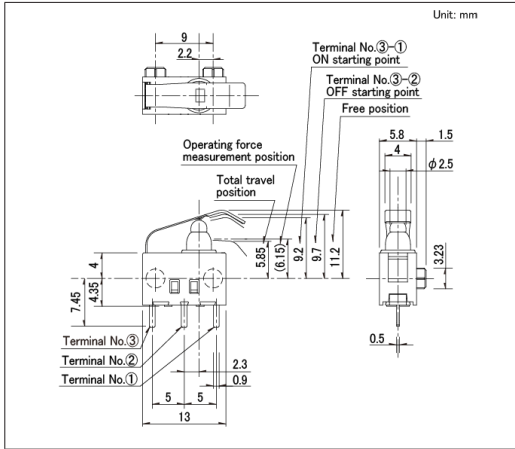

■ Circuit Diagram

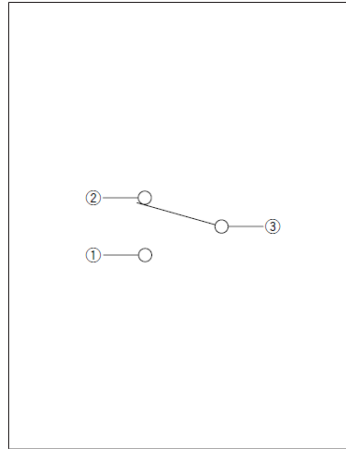

Drawing No.23

■ Dimensions

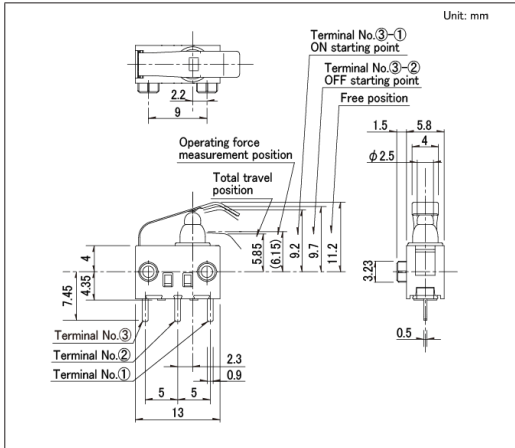

■ Circuit Diagram

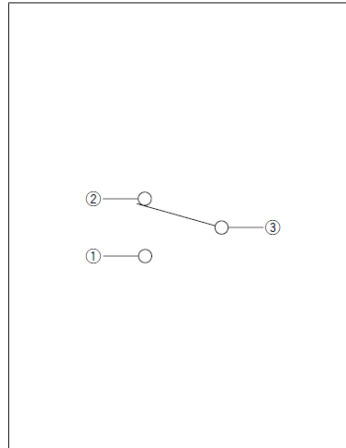

Drawing No.24

■ Dimensions

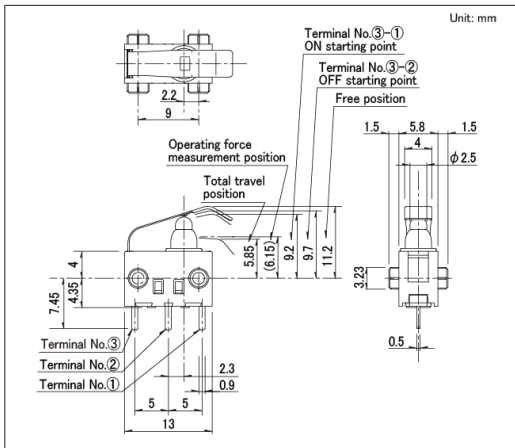

■ Circuit Diagram

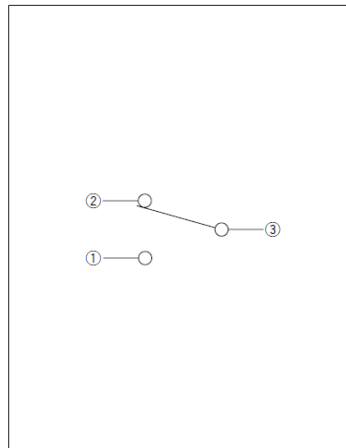

Water-proof Type
SPVQ3 Series

Drawing No.25

■ Dimensions

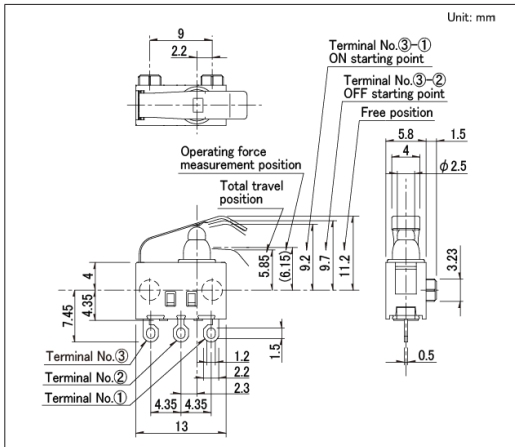

■ Circuit Diagram

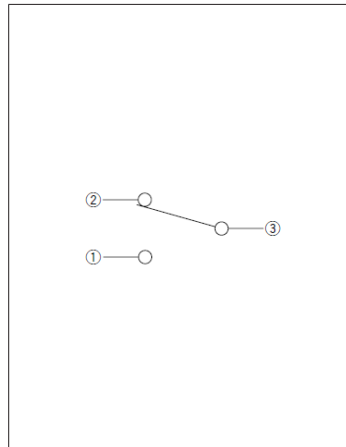

Drawing No.26

■ Dimensions

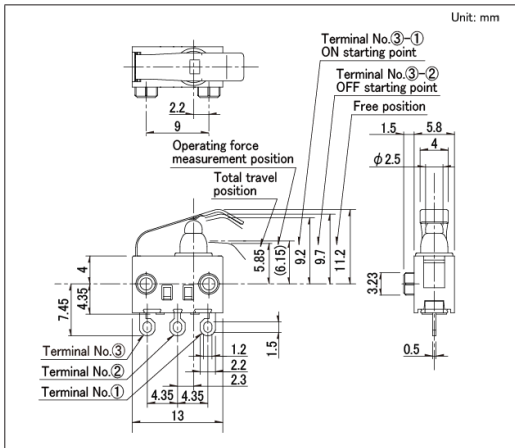

■ Circuit Diagram

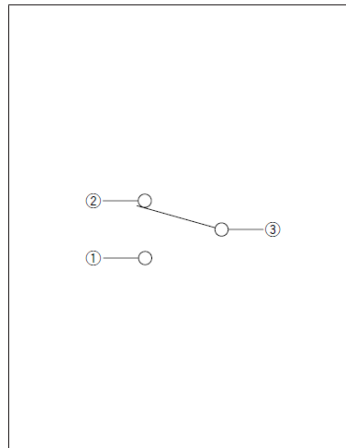

Drawing No.27

■ Dimensions

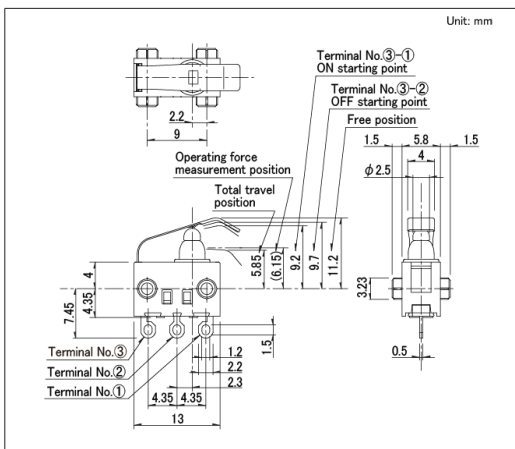

■ Circuit Diagram

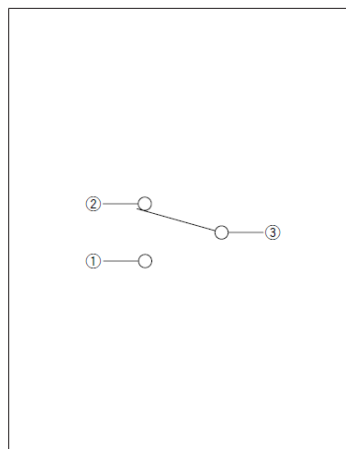

Water-proof Type
SPVQ3 Series

Drawing No.28

■ Dimensions

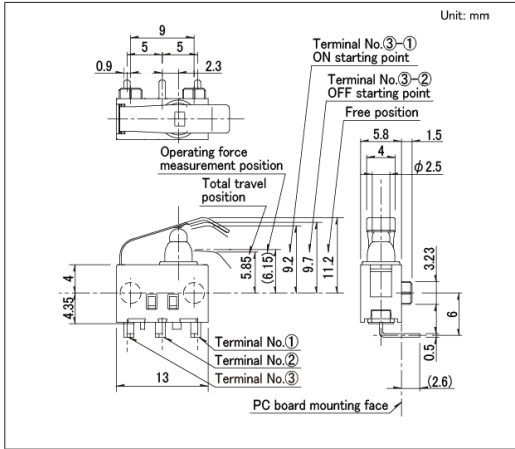

■ Circuit Diagram

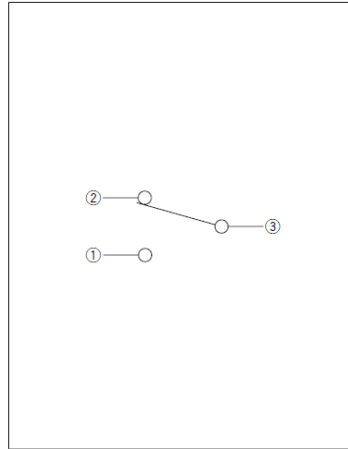

Drawing No.29

■ Dimensions

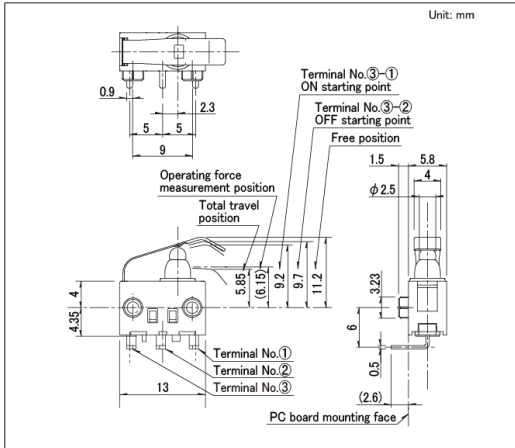

■ Circuit Diagram

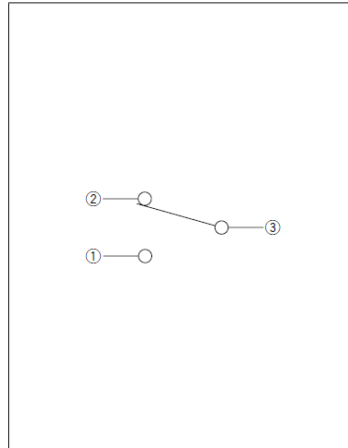

Drawing No.30

■ Dimensions

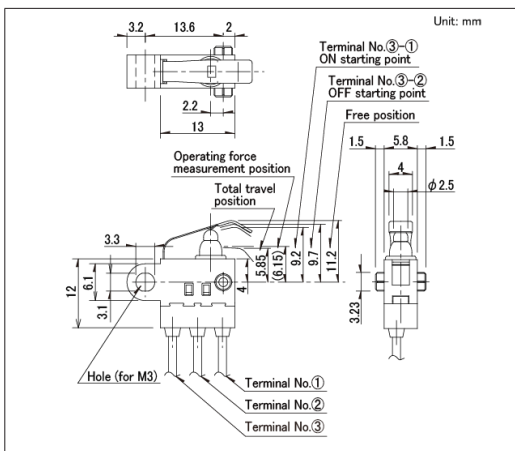

■ Circuit Diagram

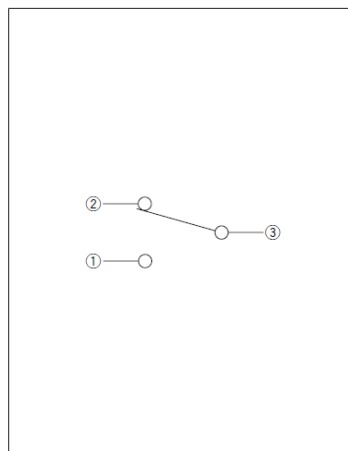

Water-proof Type
SPVQ3 Series

Drawing No.31

■ Dimensions

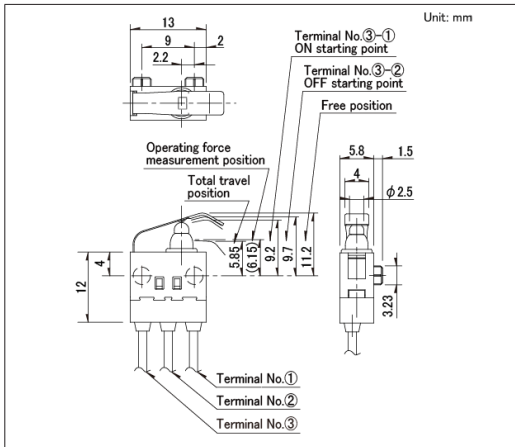

■ Circuit Diagram

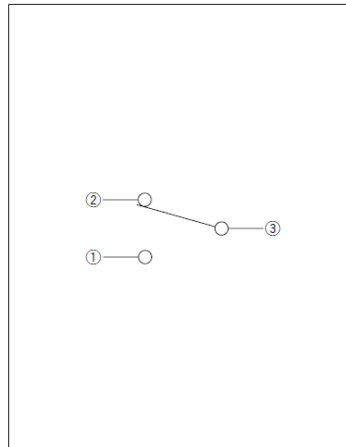

Drawing No.32

■ Dimensions

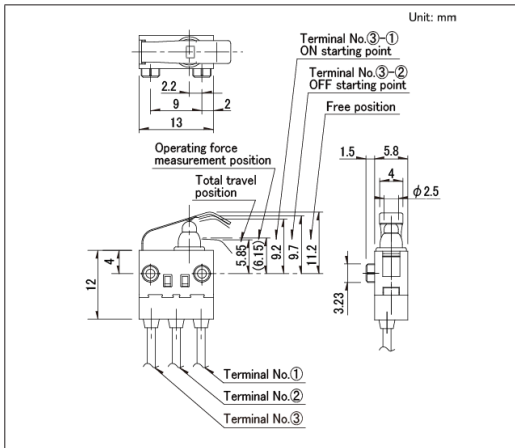

■ Circuit Diagram

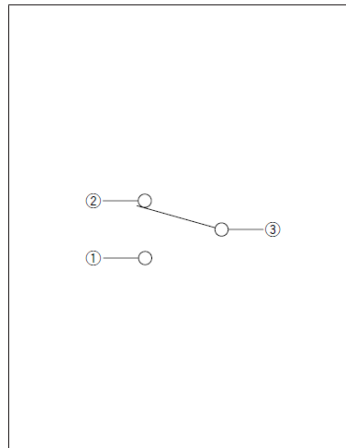

Drawing No.33

■ Dimensions

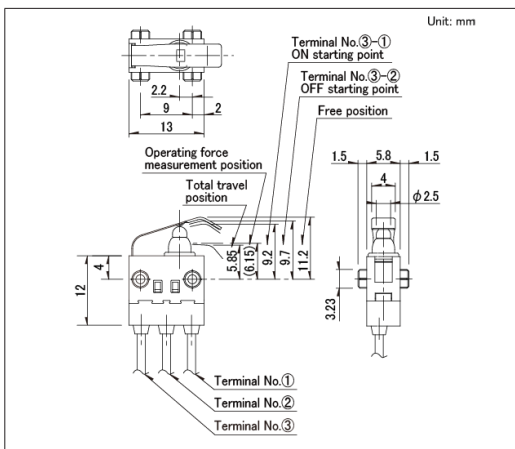

■ Circuit Diagram

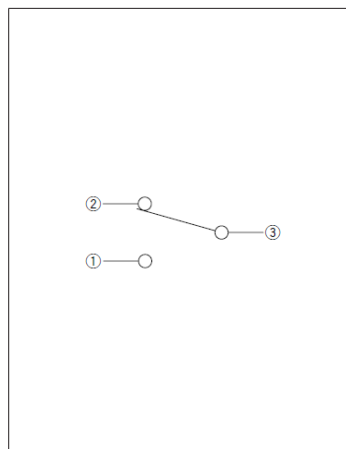

Water-proof Type
SPVQ3 Series

Drawing No.34

■ Dimensions

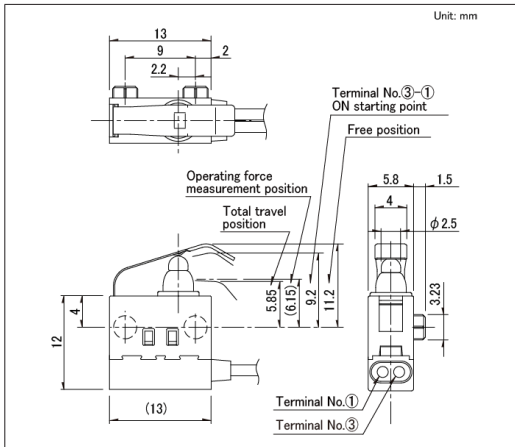

■ Circuit Diagram

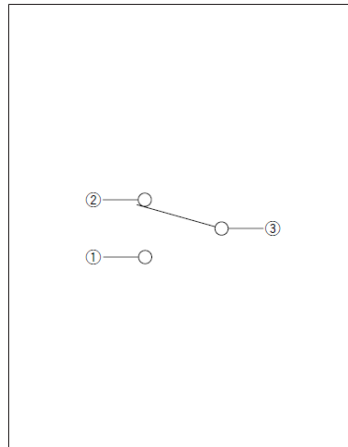

Drawing No.35

■ Dimensions

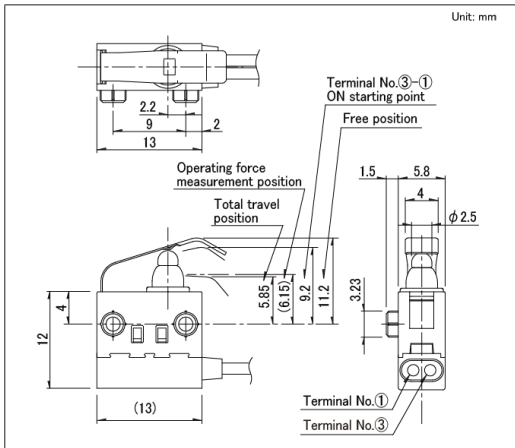

■ Circuit Diagram

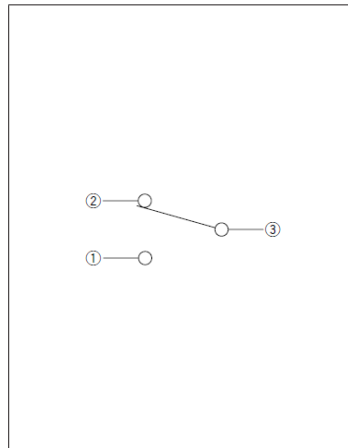

Drawing No.36

■ Dimensions

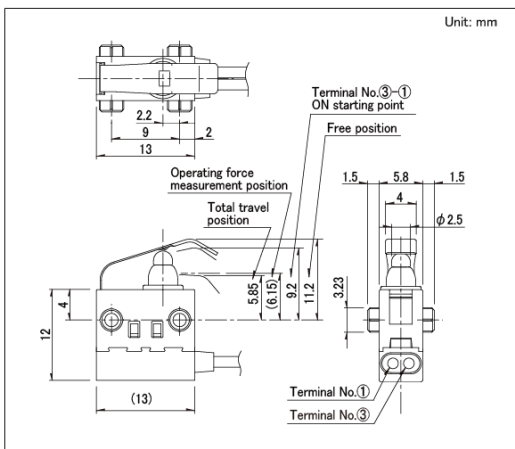

■ Circuit Diagram

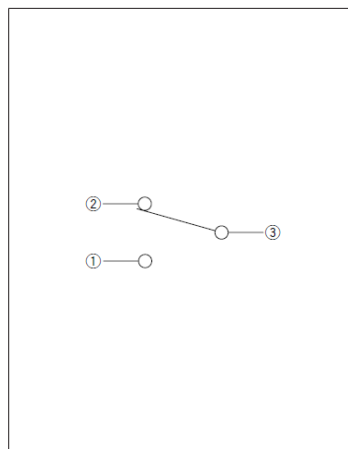

Water-proof Type
SPVQ3 Series

Drawing No.37

■ Dimensions

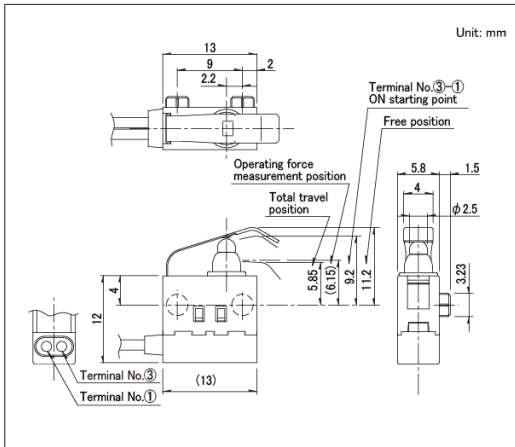

■ Circuit Diagram

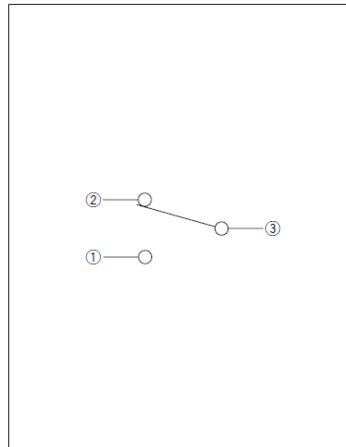

Drawing No.38

■ Dimensions

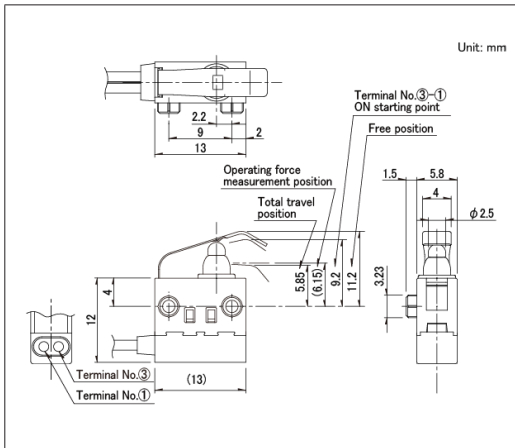

■ Circuit Diagram

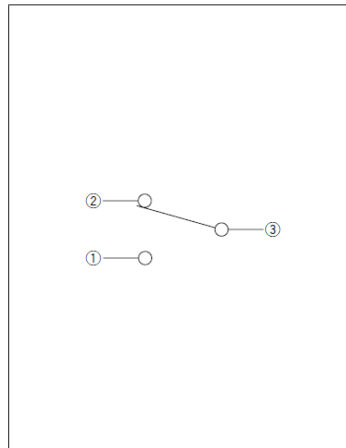

Drawing No.39

■ Dimensions

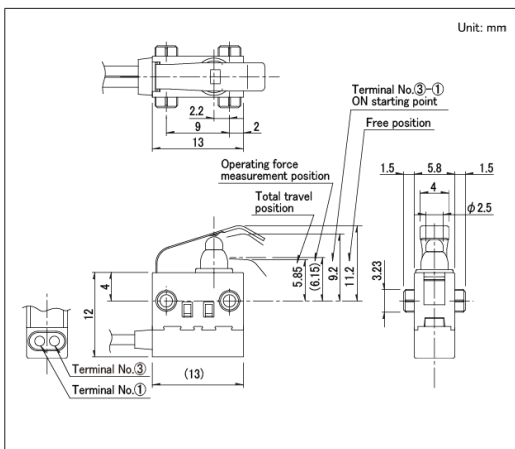

■ Circuit Diagram

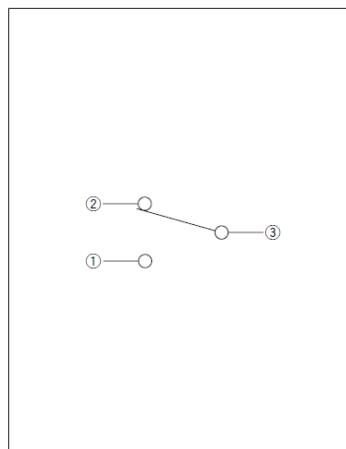

Water-proof Type
SPVQ3 Series

Drawing No.40

■ Dimensions

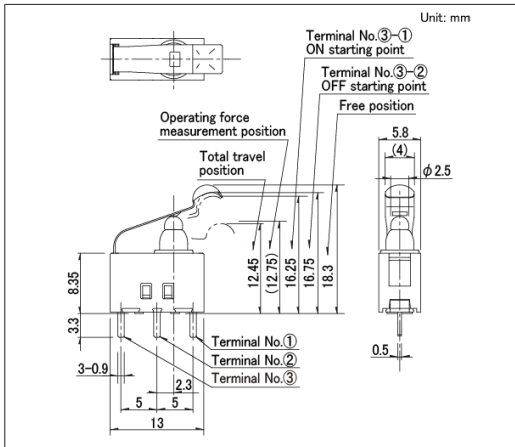

■ Circuit Diagram

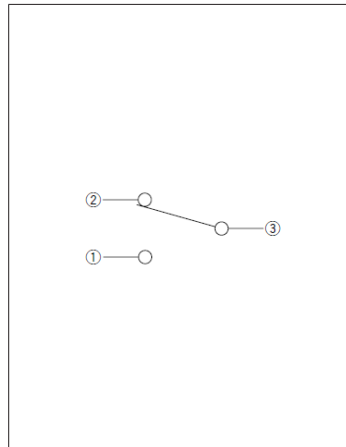

Drawing No.41

■ Dimensions

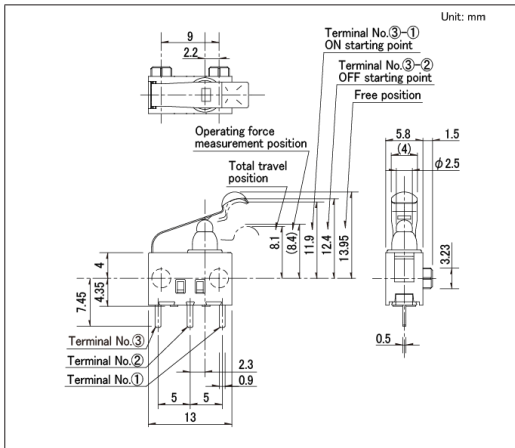

■ Circuit Diagram

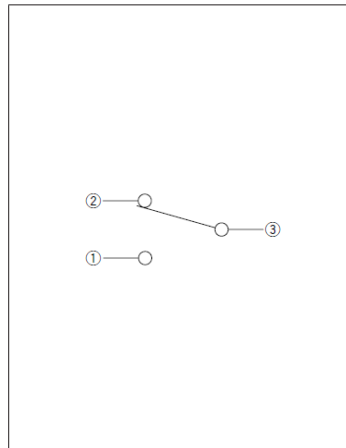

Drawing No.42

■ Dimensions

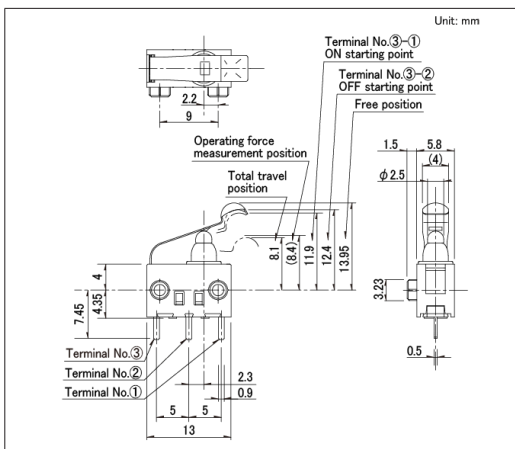

■ Circuit Diagram

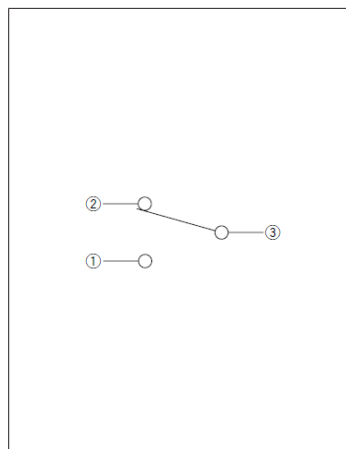

Water-proof Type
SPVQ3 Series

Drawing No.43

■ Dimensions

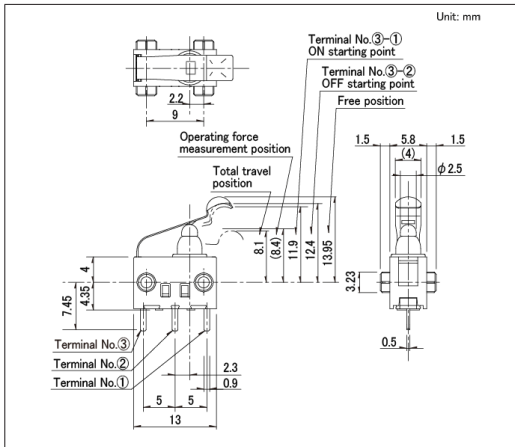

■ Circuit Diagram

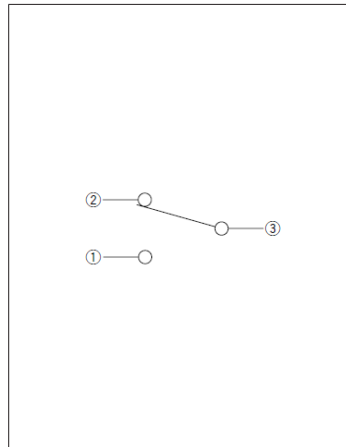

Drawing No.44

■ Dimensions

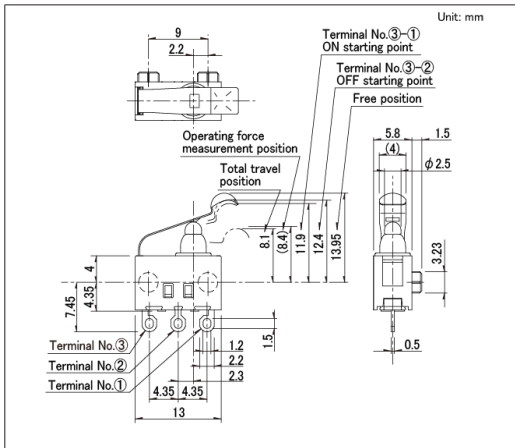

■ Circuit Diagram

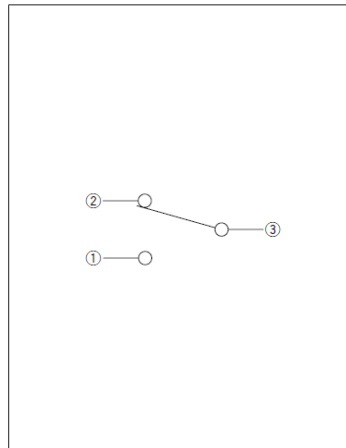

Drawing No.45

■ Dimensions

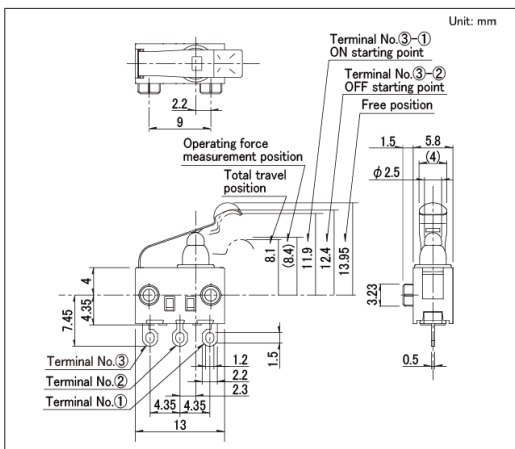

■ Circuit Diagram

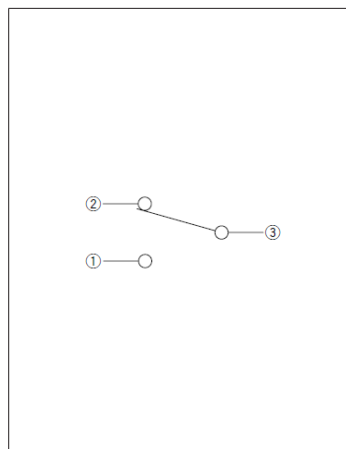

Water-proof Type
SPVQ3 Series

Drawing No.49

■ Dimensions

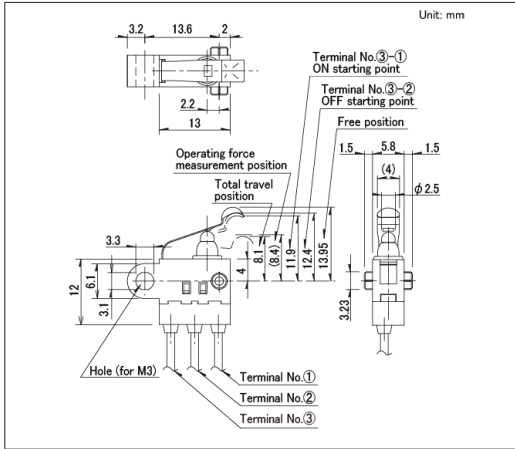

■ Circuit Diagram

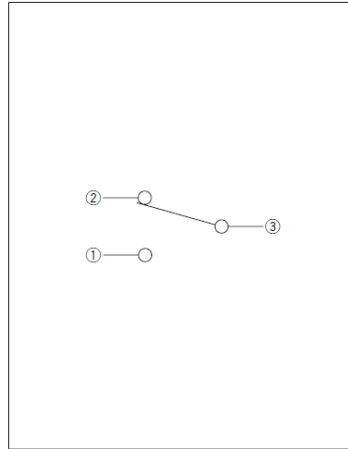

Drawing No.50

■ Dimensions

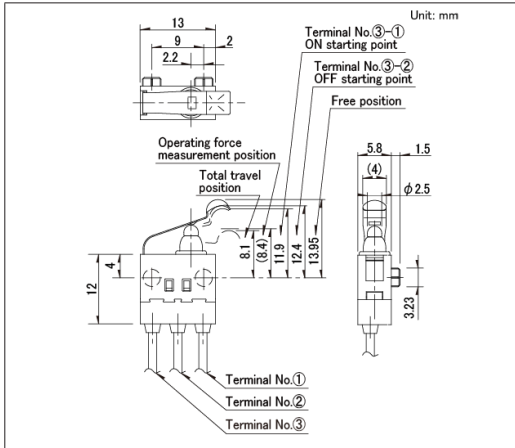

■ Circuit Diagram

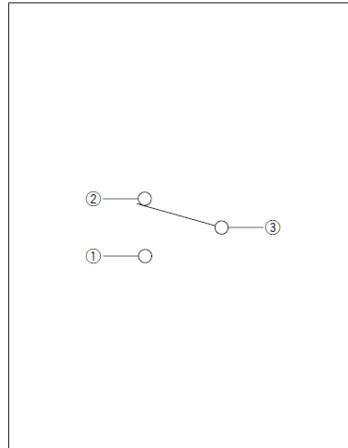

Drawing No.51

■ Dimensions

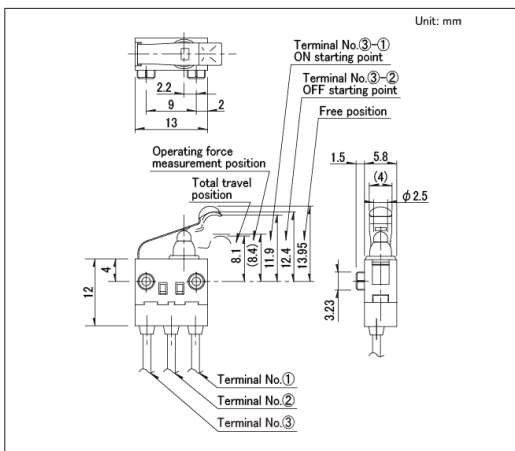

■ Circuit Diagram

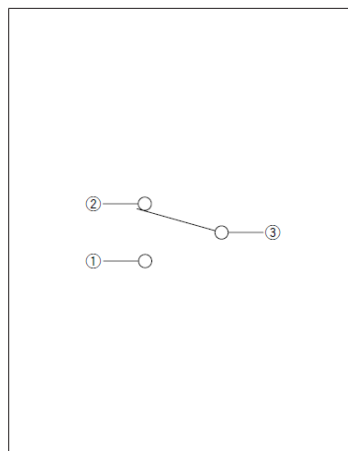

Water-proof Type
SPVQ3 Series

Drawing No.52

■ Dimensions

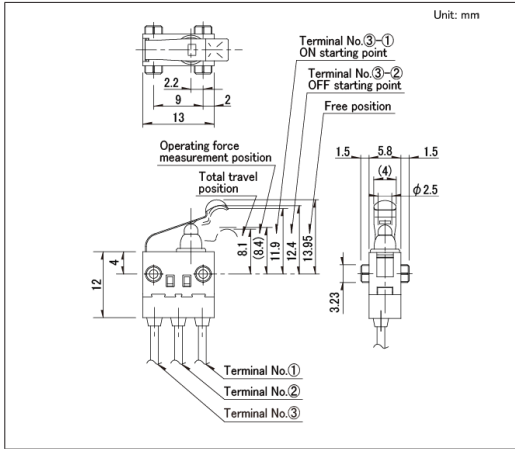

■ Circuit Diagram

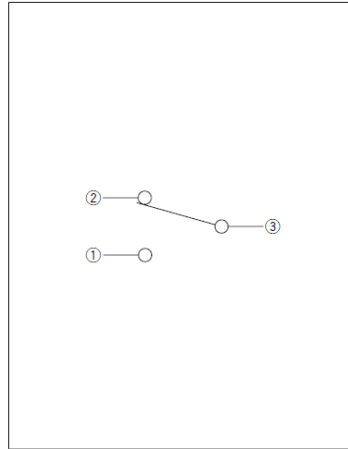

Drawing No.53

■ Dimensions

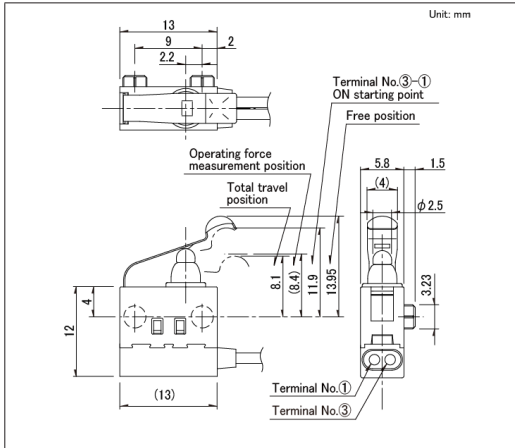

■ Circuit Diagram

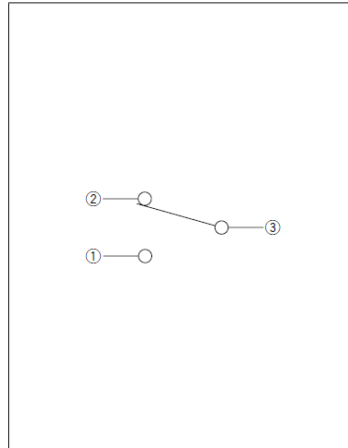

Drawing No.54

■ Dimensions

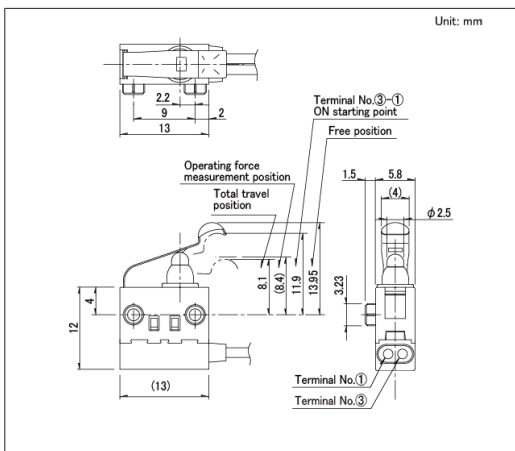

■ Circuit Diagram

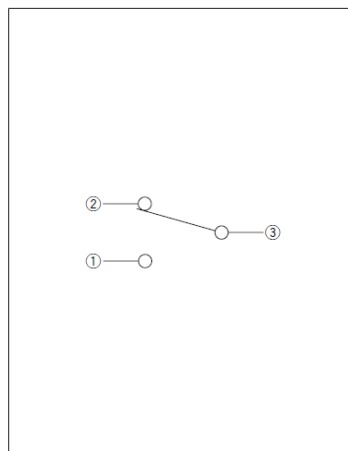

Water-proof Type
SPVQ3 Series

Drawing No.55

■ Dimensions

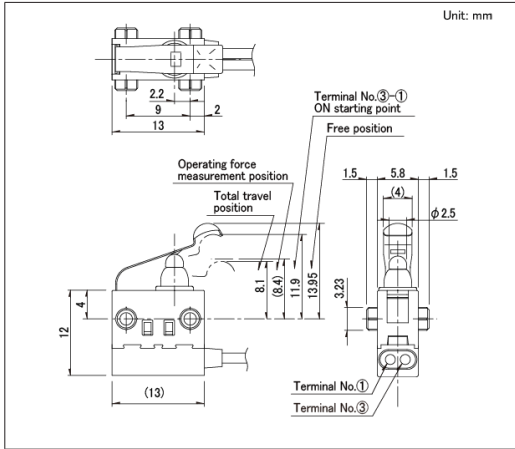

■ Circuit Diagram

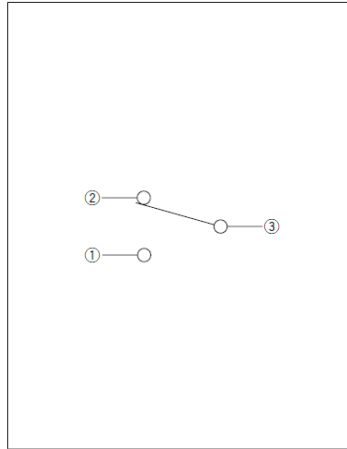

Drawing No.56

■ Dimensions

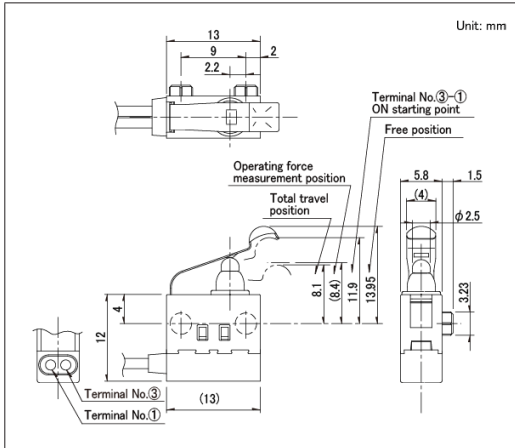

■ Circuit Diagram

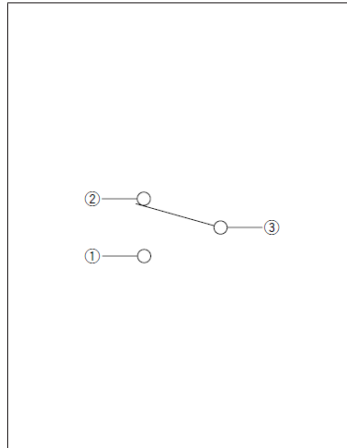

Drawing No.57

■ Dimensions

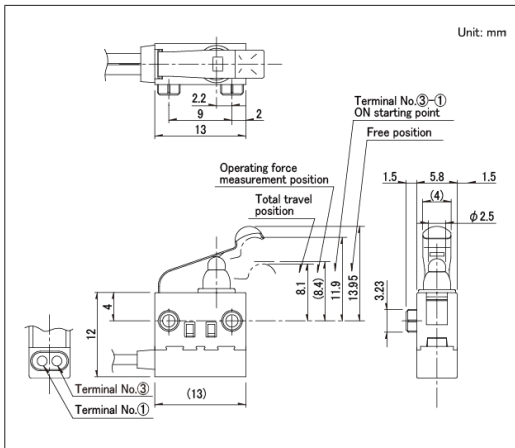

■ Circuit Diagram

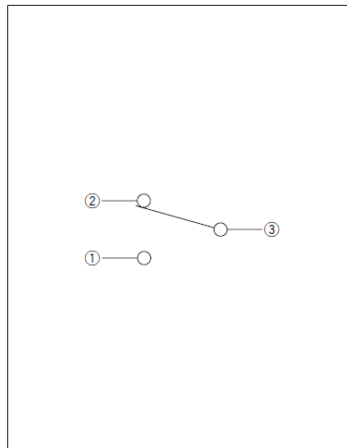

Water-proof Type
SPVQ3 Series

Drawing No.58

■ Dimensions

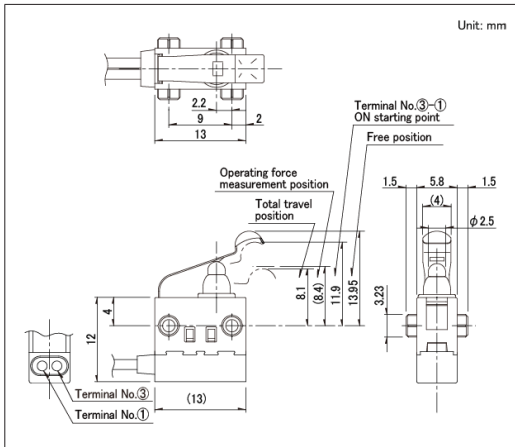

■ Circuit Diagram

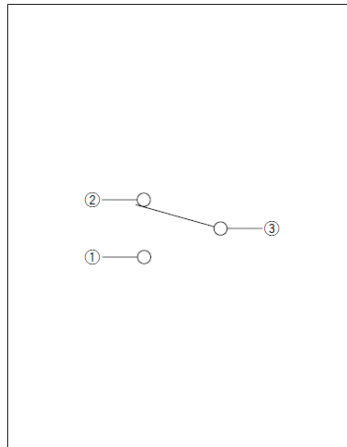

Switches

Detector Switches

Water-proof Type
SPVQ6 Series

Compact type with body dimensions of 13.3×5.3mm and a height of 7.0mm.

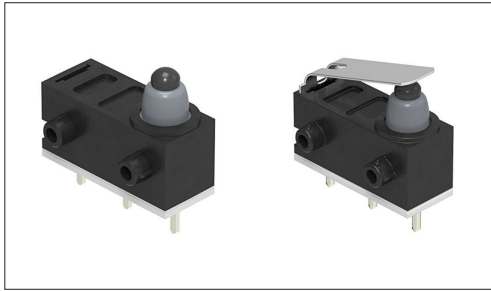

Automotive

Water-proof Type

Dust-proof Type

- Rating(max.)/(min.)(Resistive load):0.1A 12V DC/50 μ A 5V DC
- Contact resistance(Initial/After operating life):500m Ω max./1 Ω max.
- Operating life without load:300,000 cycles
- Operating life with load Rating(max.)(Resistive load):
300,000 cycles 1 Ω max.

Applications:Energy_Industrial:Robots, drones,Industrial equipment

Home:Major home appliances

Automotive:Hood Latch (Side/Rear/Door/Gear)

■ Product List

Products No.	Type	Poles	Positions	Operating force	Changeover timing	Operation part shape	Terminal type	Main body form	Dimensions (W×D×H) (mm)	Water-proof	Dust-proof	Automotive	Drawing No.
SPVQ640102	—	1	2	1±0.5N	Non shorting	Push	For PC board	Boss - right side	5.3×13.3×6.5	●	●	●	1
SPVQ640202		1	2	1±0.5N	Non shorting	Push	For PC board	Boss - left side	5.3×13.3×6.5	●	●	●	2
SPVQ630104		1	2	3N max.	Non shorting	Actuator	For PC board	Boss - right side	5.3×13.3×6.5	●	●	●	3
SPVQ630203		1	2	3N max.	Non shorting	Actuator	For PC board	Boss - left side	5.3×13.3×6.5	●	●	●	4
SPVQ6R	With internal resistor type	1	1	3N max.	Non shorting	Actuator	Press-fit (normal type)	Without boss / Left bending	5.3×13.3×6.5	●	●	●	5

Note

1. This catalog shows only outline specifications. When using the products, please obtain formal specifications for supply.
2. This unit cannot be used in water (IP6K7 rating, except for terminal).
3. Please place purchase orders per minimum order unit (integer).
4. This products can be used in vehicles.
Although these products are designed to perform over a wide operating temperature range, please ensure that you receive and read the formal delivery specifications before use.
5. For the Recommended Unit Terminal Shape for Press-Fit Terminals (Normally Open) for SPVQ6R, please check our website.

■ Packing Specifications

Tray

Number of packages(pcs.)		Export package measurements (mm)
1 case / Japan	1 case / export packing	
1,500	6,000	540×360×270

Water-proof Type
SPVQ6 Series

Drawing No.1

■ Dimensions

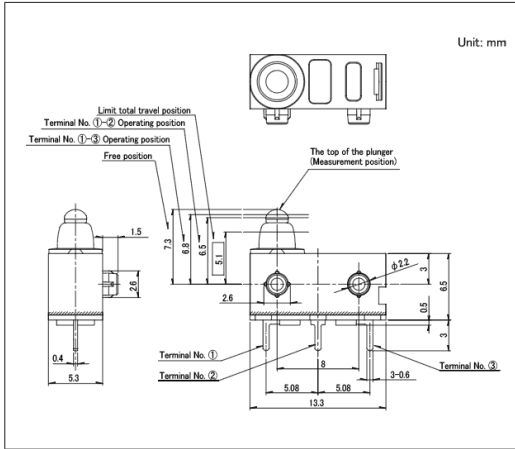

■ Circuit Diagram

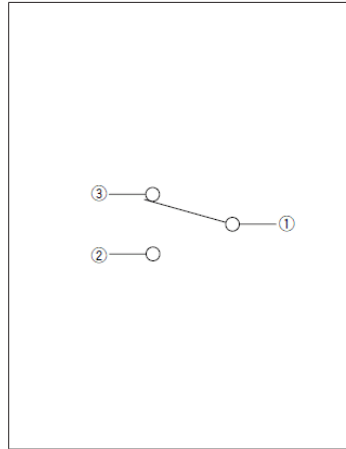

Drawing No.2

■ Dimensions

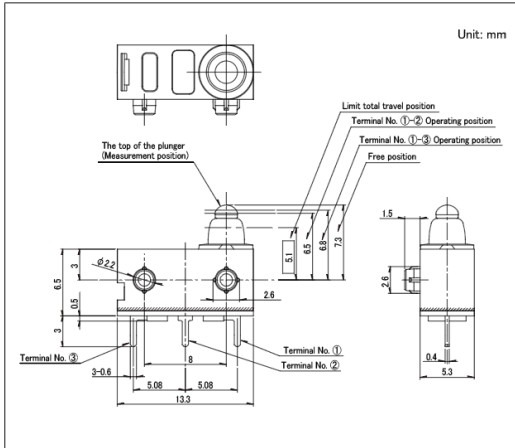

■ Circuit Diagram

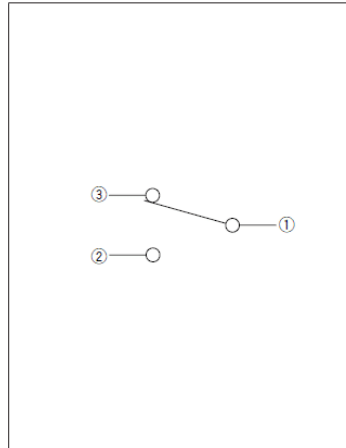

Drawing No.3

■ Dimensions

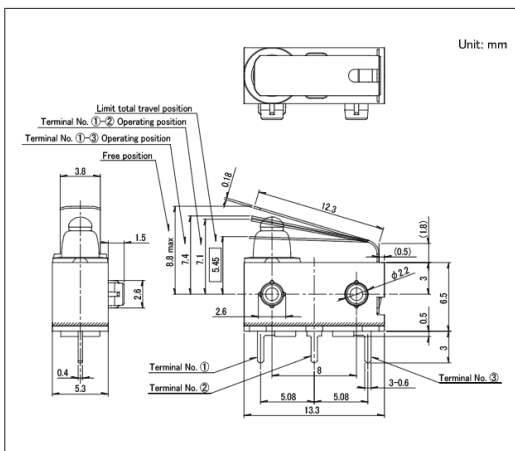

■ Circuit Diagram

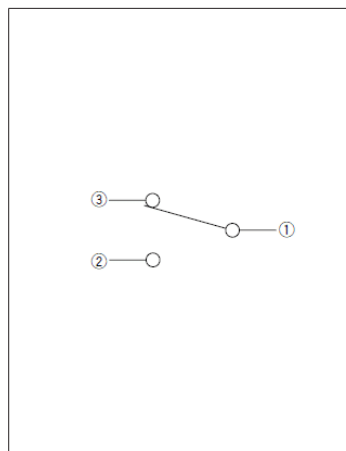

Water-proof Type
SPVQ6 Series

Drawing No.4

■ Dimensions

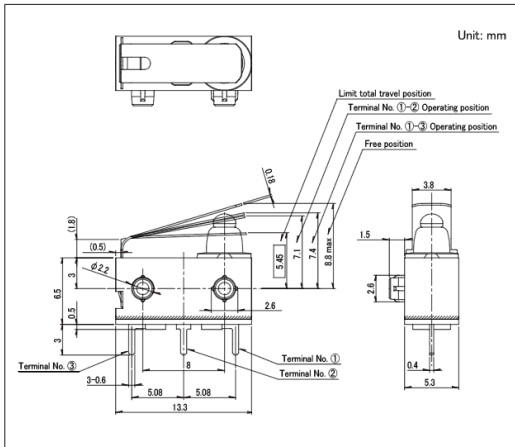

■ Circuit Diagram

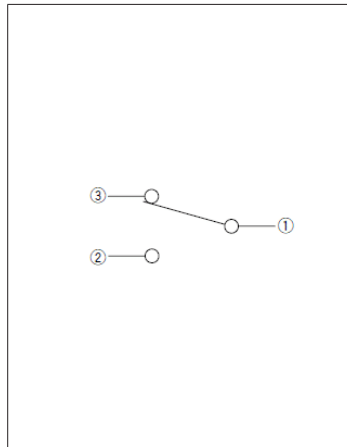

Drawing No.5

■ Dimensions

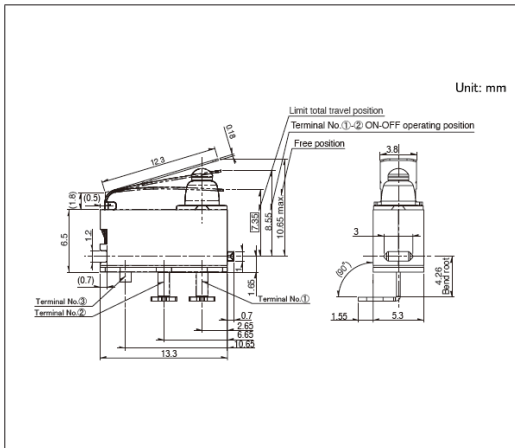

■ Circuit Diagram

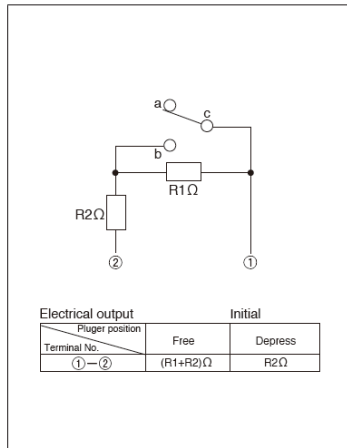

Please contact us for resistance specifications and rated power.

Water-proof Type SPVQ7 Series

Low-profile type with a body height of 6.7mm.

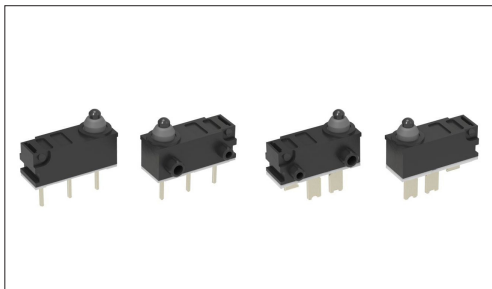

Automotive



Water-proof Type



Dust-proof Type

- Rating(max.)/(min.)(Resistive load):0.1A 12V DC/50 μ A 5V DC
- Contact resistance(Initial/After operating life):500m Ω max./1 Ω max.
- Operating life without load:300,000 cycles
- Operating life with load Rating(max.)(Resistive load):
300,000 cycles 1 Ω max.

Applications:Energy Industrial:Robots, drones,Industrial equipment
Home:Major home appliances
Automotive:Hood Latch (Side/Rear/Door/Gear)

Product List

Products No.	Poles	Positions	Operating force	Changeover timing	Operation part shape	Terminal type	Main body form	Dimensions (W×D×H) (mm)	Water-proof	Dust-proof	Automotive	Drawing No.
SPVQ710103	1	2	1±0.5N	Non shorting	Push	For PC board	Boss - left side	5.4×14.7×6.7	●	●	●	1
SPVQ710203	1	2	1±0.5N	Non shorting	Push	For PC board	Boss - right side	5.4×14.7×6.7	●	●	●	2
SPVQ710304	1	1	1±0.5N	Non shorting	Push	For PC board	Boss - left side	5.4×14.7×6.7	●	●	●	3
SPVQ710404	1	1	1±0.5N	Non shorting	Push	For PC board	Boss - right side	5.4×14.7×6.7	●	●	●	4
SPVQ740303	1	1	1±0.5N	Non shorting	Push	For Lead	Boss - left side	5.4×14.7×6.7	●	●	●	5
SPVQ740403	1	1	1±0.5N	Non shorting	Push	For Lead	Boss - right side	5.4×14.7×6.7	●	●	●	6
SPVQ740103	1	2	1±0.5N	Non shorting	Push	For Lead	Boss - left side	5.4×14.7×6.7	●	●	●	7
SPVQ740203	1	2	1±0.5N	Non shorting	Push	For Lead	Boss - right side	5.4×14.7×6.7	●	●	●	8

⚠ Note

1. This catalog shows only outline specifications. When using the products, please obtain formal specifications for supply.
2. This unit cannot be used in water (IP6K7 rating, except for terminal).
3. Please place purchase orders per minimum order unit (integer).
4. This products can be used in vehicles.

Although these products are designed to perform over a wide operating temperature range, please ensure that you receive and read the formal delivery specifications before use.

Packing Specifications

Tray

Number of packages(pcs.)		Export package measurements (mm)
1 case / Japan	1 case / export packing	
1,350	5,400	540 x 360 x 270

Water-proof Type
SPVQ7 Series

Drawing No.1

■ Dimensions

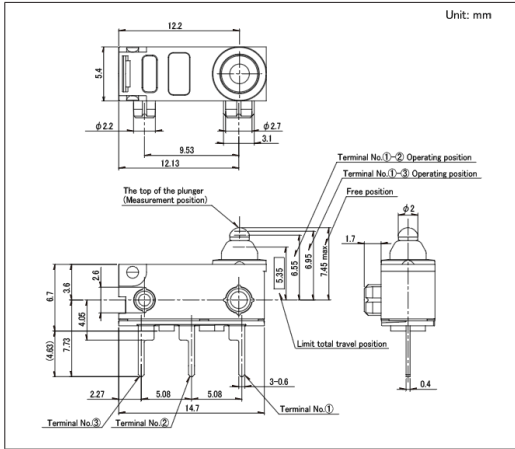

■ Circuit Diagram

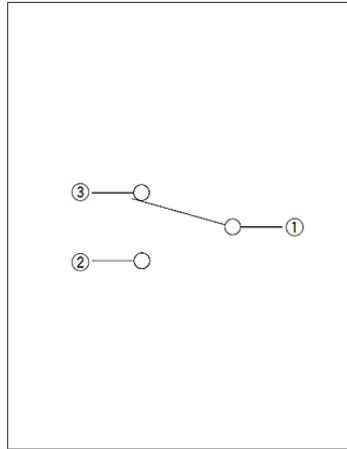

Drawing No.2

■ Dimensions

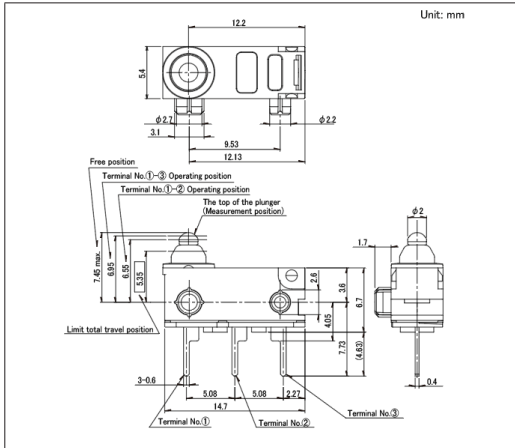

■ Circuit Diagram

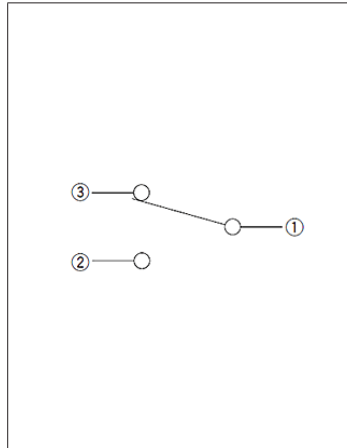

Drawing No.3

■ Dimensions

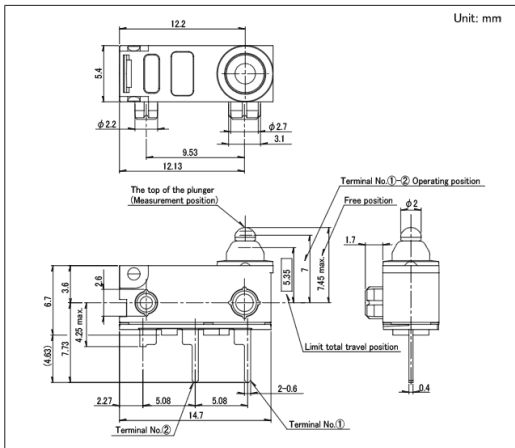

■ Circuit Diagram

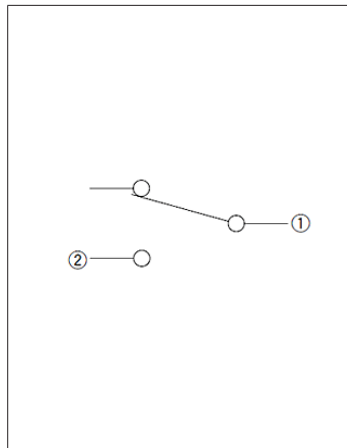

Water-proof Type
SPVQ7 Series

Drawing No.4

■ Dimensions

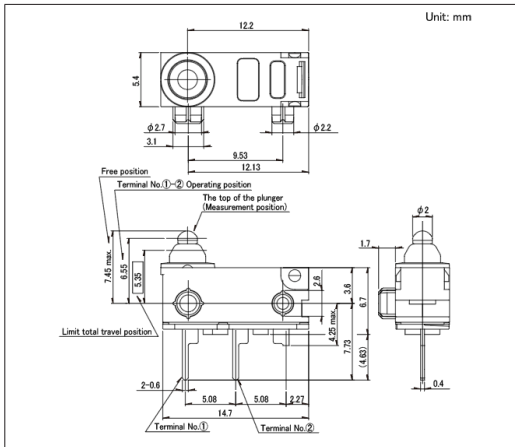

■ Circuit Diagram

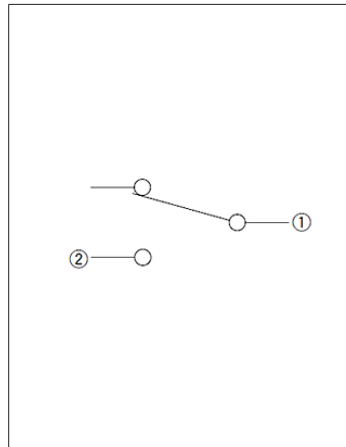

Drawing No.5

■ Dimensions

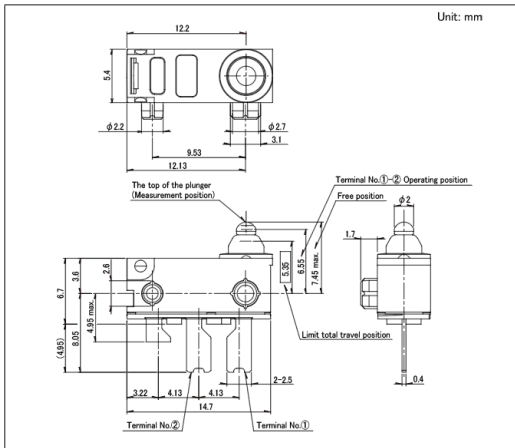

■ Circuit Diagram

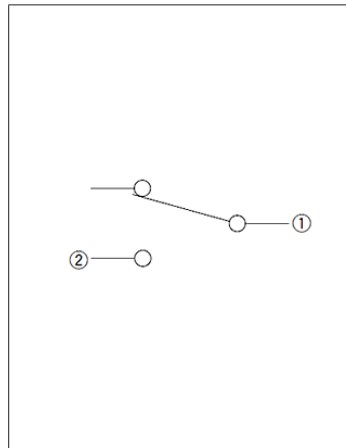

Drawing No.6

■ Dimensions

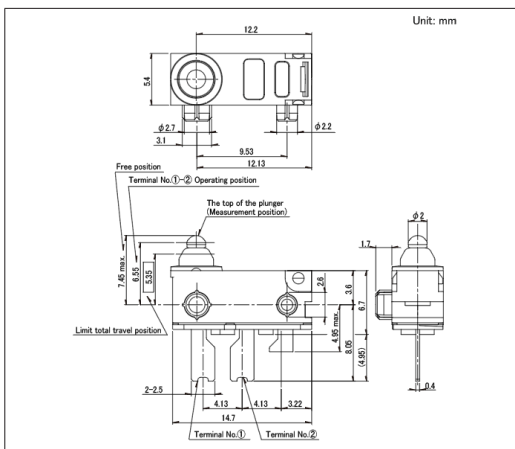

■ Circuit Diagram

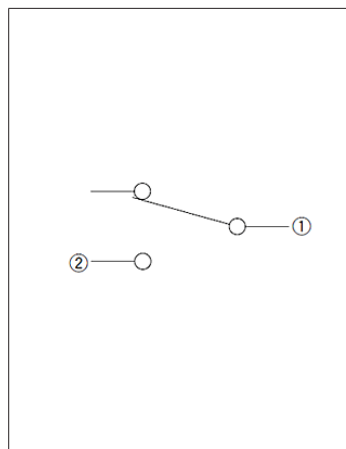

Water-proof Type
SPVQ7 Series

Drawing No.7

■ Dimensions

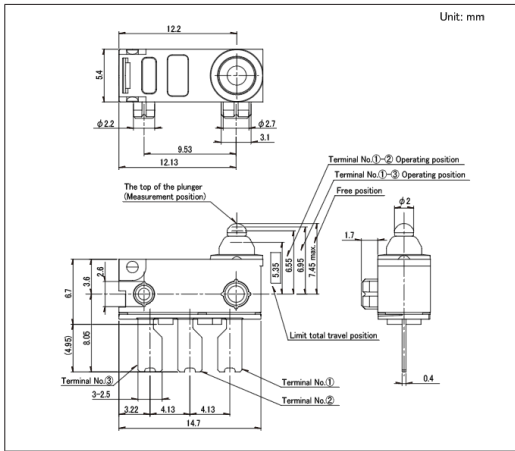

■ Circuit Diagram

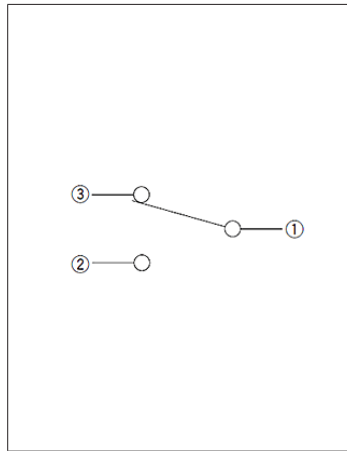

Drawing No.8

■ Dimensions

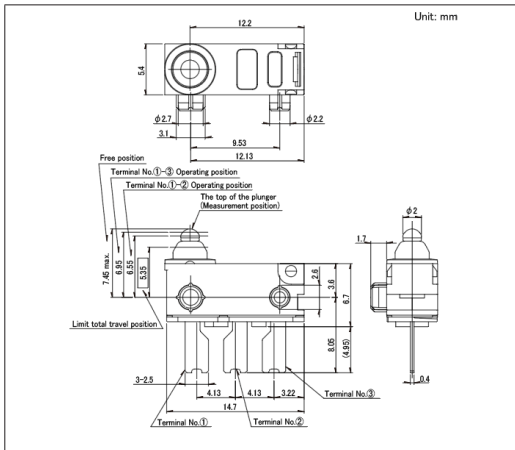

■ Circuit Diagram

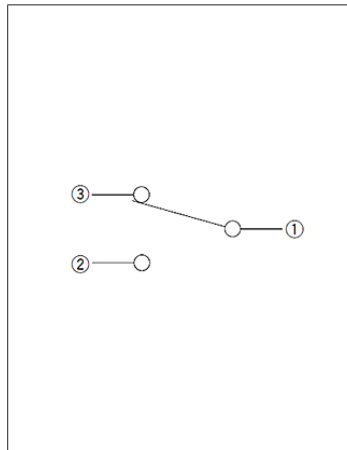

Water-proof Type SPVQ8 Series

Offers a wide product variety with an industry-leading compact size of 8.3×5.3×7.0mm body dimensions.



Automotive

Water-proof Type

Dust-proof Type

- Rating(max.)/(min.)(Resistive load):0.1A 16V DC/50μA 5V DC
- Contact resistance(Initial/After operating life):500mΩ max./1Ω max.
- Operating life without load:300,000 cycles
- Operating life with load Rating(max.)(Resistive load):
300,000 cycles 1Ω max.

Applications:Energy Industrial:Robots, drones,Industrial equipment
Home:Major home appliances
Automotive:Hood Latch (Side/Rear/Door/Gear)

Product List

Products No.	Type	Poles	Positions	Operating force	Terminal type	Circuit	Main body form	Dimensions (W×D×H) (mm)	Water-proof	Dust-proof	Automotive	Drawing No.
SPVQ810102	Standard type	1	1	1±0.5N	For PC board	N/O	Boss - both sides	5.3×8.3×6.5	●	●	●	1
SPVQ810302		1	1	1±0.5N	Angle	N/O	Boss - single side	5.3×8.3×6.5	●	●	●	2
SPVQ810402		1	1	1±0.5N	Angle	N/O	Without boss	5.3×8.3×6.5	●	●	●	3
SPVQ810502		1	1	1±0.5N	For PC board	N/O	Without boss	5.3×8.3×6.5	●	●	●	4
SPVQ810602		1	1	1±0.5N	For PC board	N/O	Boss - single side	5.3×8.3×6.5	●	●	●	5
SPVQ810704		1	1	1±0.5N	For Lead	N/O	Boss - single side	5.3×8.3×6.5	●	●	●	6
SPVQ810802		1	1	1±0.5N	For Lead	N/O	Boss - both sides	5.3×8.3×6.5	●	●	●	7
SPVQ811006		1	1	1±0.5N	Press-fit (normal type)	N/O	Boss - single side	5.3×8.3×6.5	●	●	●	8
SPVQ820102		1	1	1±0.5N	For PC board	N/C	Boss - both sides	5.3×8.3×6.5	●	●	●	9
SPVQ820302		1	1	1±0.5N	Angle	N/C	Boss - single side	5.3×8.3×6.5	●	●	●	10
SPVQ820402		1	1	1±0.5N	Angle	N/C	Without boss	5.3×8.3×6.5	●	●	●	11
SPVQ820502		1	1	1±0.5N	For PC board	N/C	Without boss	5.3×8.3×6.5	●	●	●	12
SPVQ820602		1	1	1±0.5N	For PC board	N/C	Boss - single side	5.3×8.3×6.5	●	●	●	13
SPVQ820705		1	1	1±0.5N	For Lead	N/C	Boss - single side	5.3×8.3×6.5	●	●	●	14
SPVQ820802		1	1	1±0.5N	For Lead	N/C	Boss - both sides	5.3×8.3×6.5	●	●	●	15
SPVQ821006		1	1	1±0.5N	Press-fit (normal type)	N/C	Boss - single side	5.3×8.3×6.5	●	●	●	16
SPVQ850101		1	1	1±0.5N	With wire (Downwards)	N/O	Boss - single side	5.3×8.3×6.5	●	●	●	17
SPVQ850201		1	1	1±0.5N	With wire (Downwards)	N/O	Boss - both sides	5.3×8.3×6.5	●	●	●	18
SPVQ850301		1	1	1±0.5N	With wire (Left side)	N/O	Boss - single side	5.3×8.3×6.5	●	●	●	19
SPVQ850501		1	1	1±0.5N	With wire (from side)	N/O	Boss - both sides	5.3×8.3×6.5	●	●	●	20
SPVQ860101		1	1	1±0.5N	With wire (Downwards)	N/C	Boss - single side	5.3×8.3×6.5	●	●	●	21
SPVQ860200		1	1	1±0.5N	With wire (Downwards)	N/C	Boss - both sides	5.3×8.3×6.5	●	●	●	22
SPVQ860301		1	1	1±0.5N	With wire (Left side)	N/C	Boss - single side	5.3×8.3×6.5	●	●	●	23
SPVQ860500		1	1	1±0.5N	With wire (from side)	N/C	Boss - both sides	5.3×8.3×6.5	●	●	●	24

Water-proof Type
SPVQ8 Series

Products No.	Type	Poles	Positions	Operating force	Terminal type	Circuit	Main body form	Dimensions (W×D×H) (mm)	Water-proof	Dust-proof	Automotive	Drawing No.
SPVQ811502	Standard type	1	1	1±0.5N	Press-fit (Short type)	N/O	Boss - single side	5.3×8.3×6.5	●	●	●	25
SPVQ821500		1	1	1±0.5N	Press-fit (Short type)	N/C	Boss - single side	5.3×8.3×6.5	●	●	●	26
SPVQ812600		1	1	3N max.	For Lead	N/O	Boss - right side	5.3×8.3×6.5	●	●	●	27
SPVQ812400		1	1	3N max.	Press-fit (normal type)	N/O	Boss - right side	5.3×8.3×6.5	●	●	●	28
SPVQ812200		1	1	3N max.	Press-fit (Short type)	N/O	Boss - right side	5.3×8.3×6.5	●	●	●	29
SPVQ812700		1	1	3N max.	For Lead	N/O	Boss - left side	5.3×8.3×6.5	●	●	●	30
SPVQ812500		1	1	3N max.	Press-fit (normal type)	N/O	Boss - left side	5.3×8.3×6.5	●	●	●	31
SPVQ812300		1	1	3N max.	Press-fit (Short type)	N/O	Boss - left side	5.3×8.3×6.5	●	●	●	32
SPVQ822500		1	1	3N max.	For Lead	N/C	Boss - right side	5.3×8.3×6.5	●	●	●	33
SPVQ822300		1	1	3N max.	Press-fit (normal type)	N/C	Boss - right side	5.3×8.3×6.5	●	●	●	34
SPVQ822100		1	1	3N max.	Press-fit (Short type)	N/C	Boss - right side	5.3×8.3×6.5	●	●	●	35
SPVQ822600		1	1	3N max.	For Lead	N/C	Boss - left side	5.3×8.3×6.5	●	●	●	36
SPVQ822400		1	1	3N max.	Press-fit (normal type)	N/C	Boss - left side	5.3×8.3×6.5	●	●	●	37
SPVQ822200		1	1	3N max.	Press-fit (Short type)	N/C	Boss - left side	5.3×8.3×6.5	●	●	●	38
SPVQ830102		Long life type	1	1	1±0.5N	For PC board	N/O	Boss - both sides	5.3×8.3×6.5	●	●	●
SPVQ830302	1		1	1±0.5N	Angle	N/O	Boss - single side	5.3×8.3×6.5	●	●	●	40
SPVQ830402	1		1	1±0.5N	Angle	N/O	Without boss	5.3×8.3×6.5	●	●	●	41
SPVQ830502	1		1	1±0.5N	For PC board	N/O	Without boss	5.3×8.3×6.5	●	●	●	42
SPVQ830602	1		1	1±0.5N	For PC board	N/O	Boss - single side	5.3×8.3×6.5	●	●	●	43
SPVQ830702	1		1	1±0.5N	For Lead	N/O	Boss - single side	5.3×8.3×6.5	●	●	●	44
SPVQ830802	1		1	1±0.5N	For Lead	N/O	Boss - both sides	5.3×8.3×6.5	●	●	●	45
SPVQ831002	1		1	1±0.5N	Press-fit (normal type)	N/O	Boss - single side	5.3×8.3×6.5	●	●	●	46
SPVQ8R02	Normal type With internal resistor type	1	1	1±0.5N	For PC board	—	Boss - single side	5.3×8.3×6.5	●	●	●	47
SPVQ8R06		1	1	1±0.5N	Press-fit (normal type)	—	Boss - single side	5.3×8.3×6.5	●	●	●	48
SPVQ8R01		1	1	1±0.5N	Press-fit (Short type)	—	Boss - single side	5.3×8.3×6.5	●	●	●	49

 Note

1. This catalog shows only outline specifications. When using the products, please obtain formal specifications for supply.
2. Unless specified, the length of the lead wire is 250mm. Color is either red or black. For length modification, please contact us.
3. Please specify circuits (N.O. or N.C.) for wired (side) types. Unless specified, the circuit will apply N.O.
4. This unit cannot be used in water (IP6K7 rating, except for terminal).
5. Please place purchase orders per minimum order unit (integer).
6. This products can be used in vehicles.

Although these products are designed to perform over a wide operating temperature range, please ensure that you receive and read the formal delivery specifications before use.

Water-proof Type
SPVQ8 Series

■ Packing Specifications

Tray

Products No.	Number of packages(pcs.)		Export package measurements (mm)
	1 case / Japan	1 case / export packing	
SPVQ810102 SPVQ810302 SPVQ810402 SPVQ810502 SPVQ810602 SPVQ810704 SPVQ810802 SPVQ811006 SPVQ820102 SPVQ820302 SPVQ820402 SPVQ820502 SPVQ820602 SPVQ820705 SPVQ820802 SPVQ821006 SPVQ811502 SPVQ821500 SPVQ830102 SPVQ830302 SPVQ830402 SPVQ830502 SPVQ830602 SPVQ830702 SPVQ830802 SPVQ831002 SPVQ8R02 SPVQ8R06 SPVQ8R01	1,755	7,020	540 x 360 x 270
SPVQ812600 SPVQ812400 SPVQ812200 SPVQ812700 SPVQ812500 SPVQ812300 SPVQ822500 SPVQ822300 SPVQ822100 SPVQ822600 SPVQ822400 SPVQ822200	1,080	4,320	540 x 360 x 270

Bulk

Products No.	Number of packages(pcs.)		Export package measurements (mm)
	1 case / Japan	1 case / export packing	
SPVQ850101 SPVQ850201 SPVQ850301 SPVQ850501 SPVQ860101 SPVQ860200 SPVQ860301 SPVQ860500	400	1,600	555 x 375 x 223

Drawing No. 1

■ Dimensions

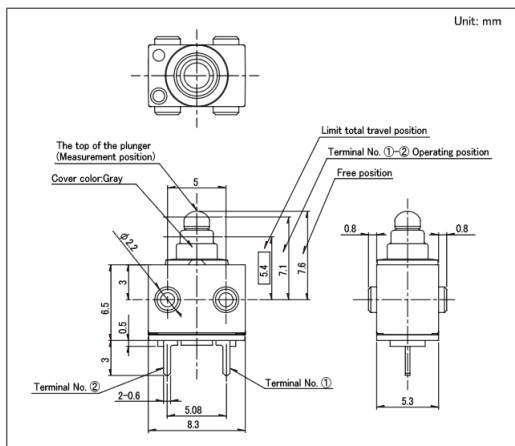

■ Circuit Diagram

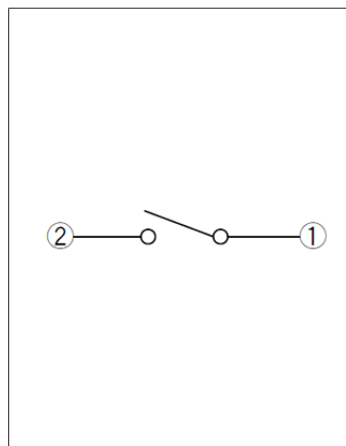

Water-proof Type
SPVQ8 Series

Drawing No.2

■ Dimensions

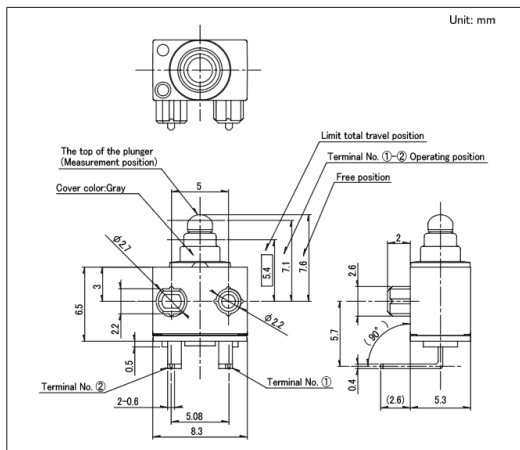

■ Circuit Diagram

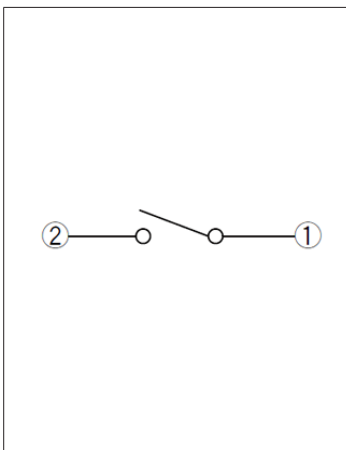

Drawing No.3

■ Dimensions

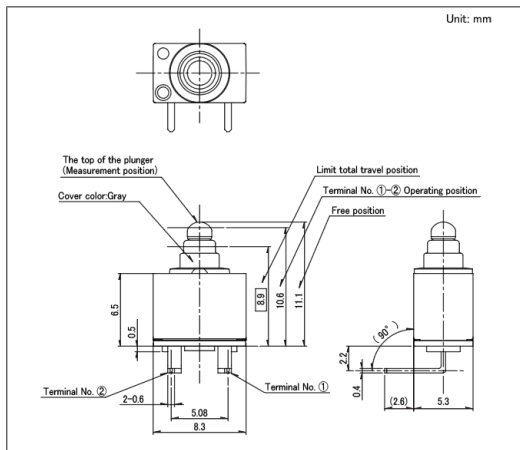

■ Circuit Diagram

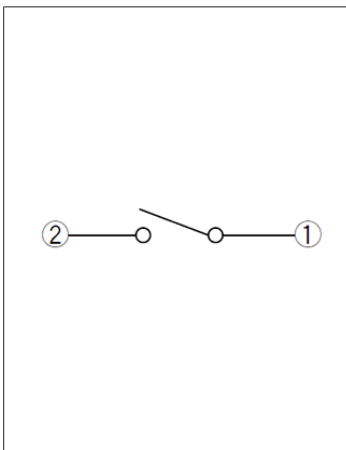

Drawing No.4

■ Dimensions

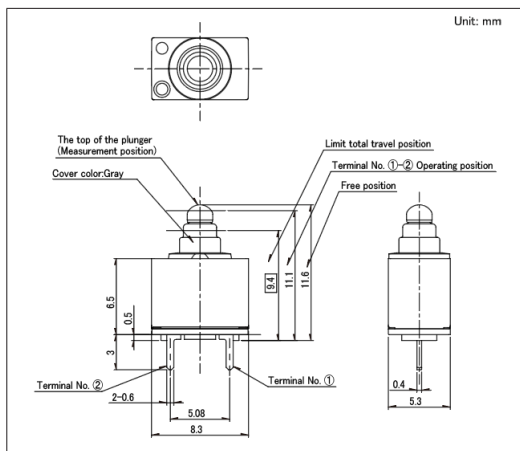

■ Circuit Diagram

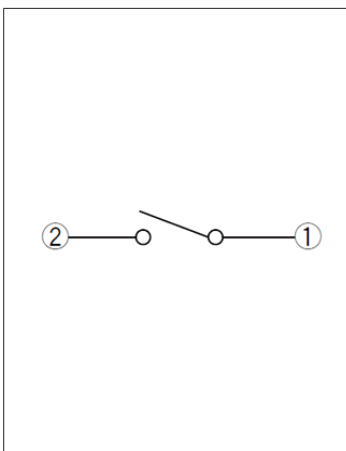

Water-proof Type
SPVQ8 Series

Drawing No.5

■ Dimensions

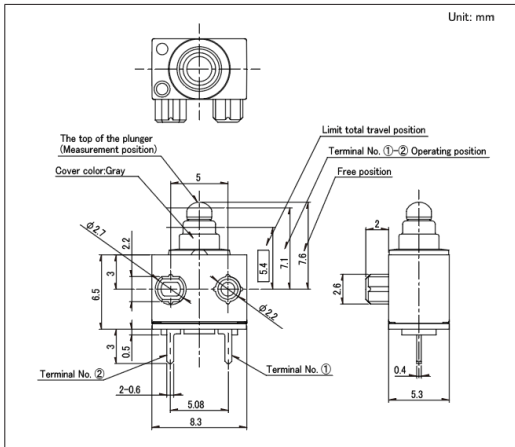

■ Circuit Diagram

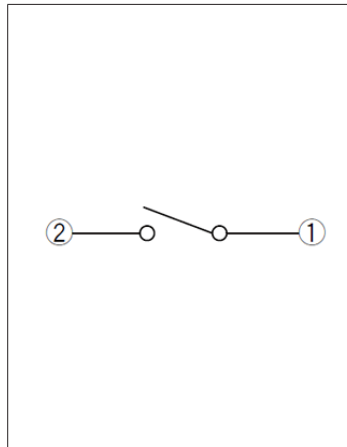

Drawing No.6

■ Dimensions

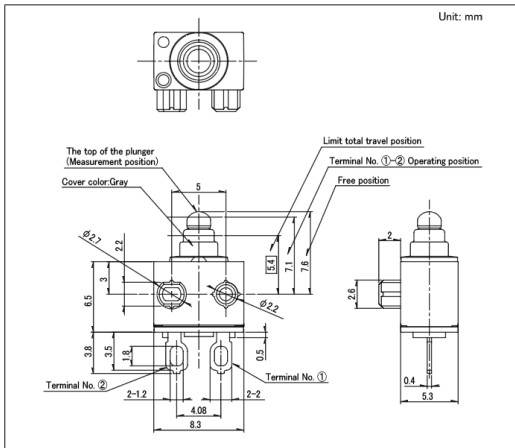

■ Circuit Diagram

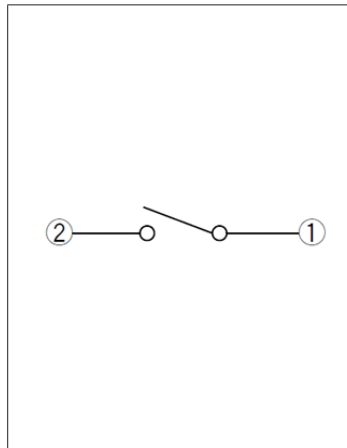

Drawing No.7

■ Dimensions

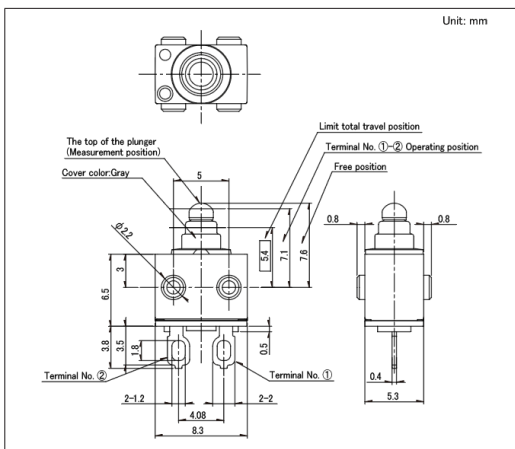

■ Circuit Diagram

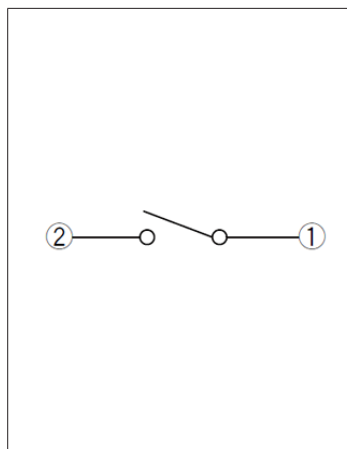

Water-proof Type
SPVQ8 Series

Drawing No.8

■ Dimensions

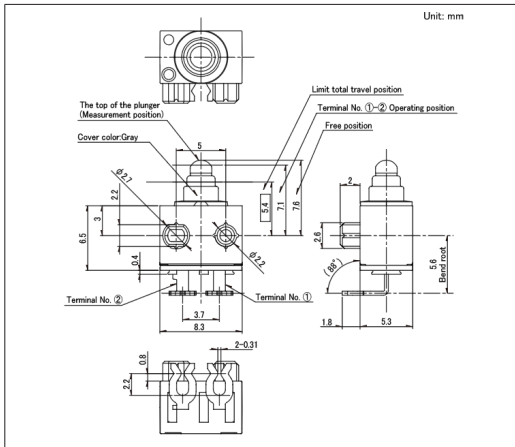

■ Circuit Diagram

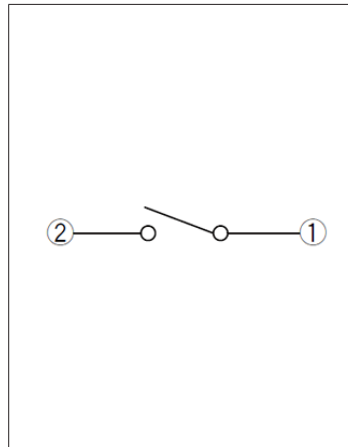

Drawing No.9

■ Dimensions

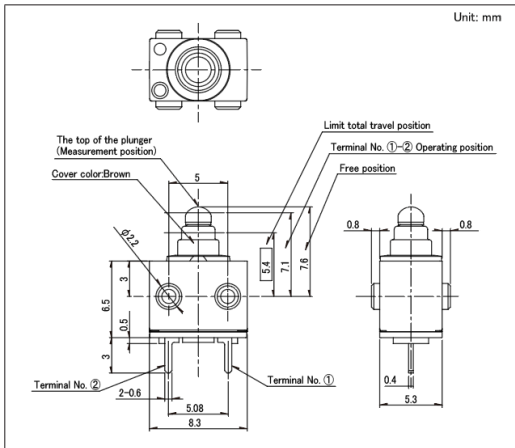

■ Circuit Diagram

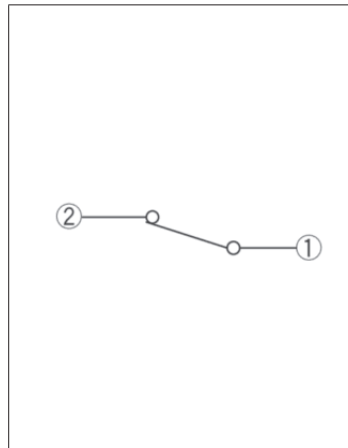

Drawing No.10

■ Dimensions

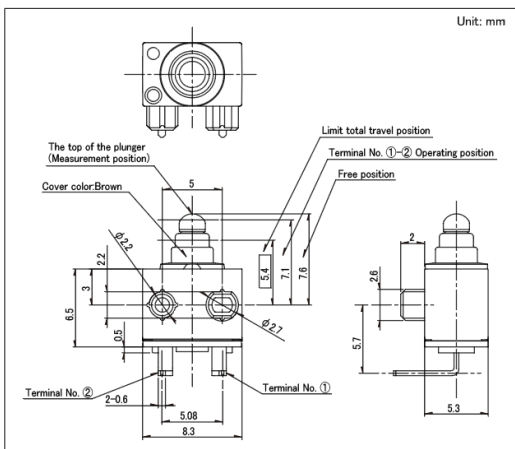

■ Circuit Diagram

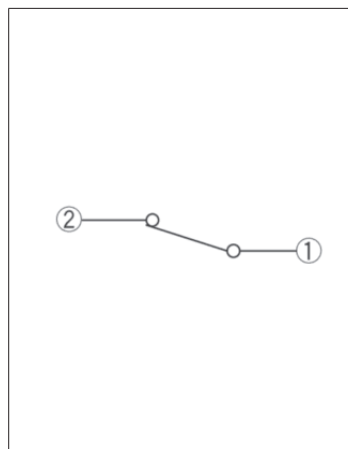

Water-proof Type
SPVQ8 Series

Drawing No.11

■ Dimensions

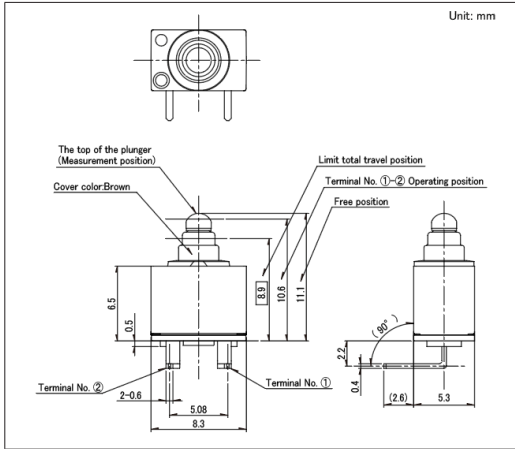

■ Circuit Diagram

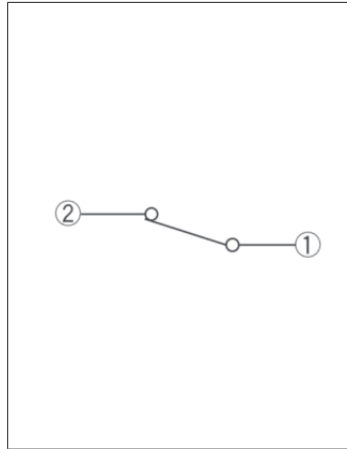

Drawing No.12

■ Dimensions

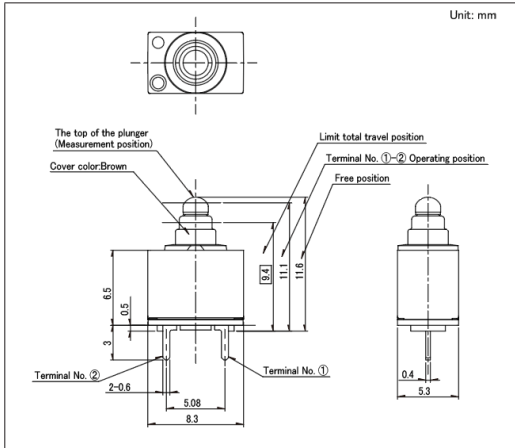

■ Circuit Diagram

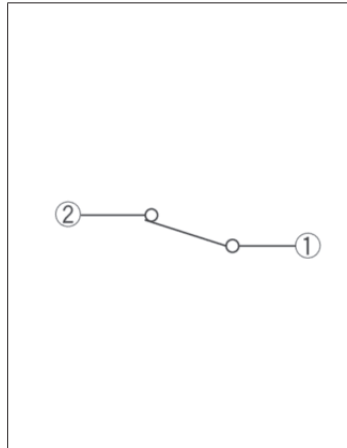

Drawing No.13

■ Dimensions

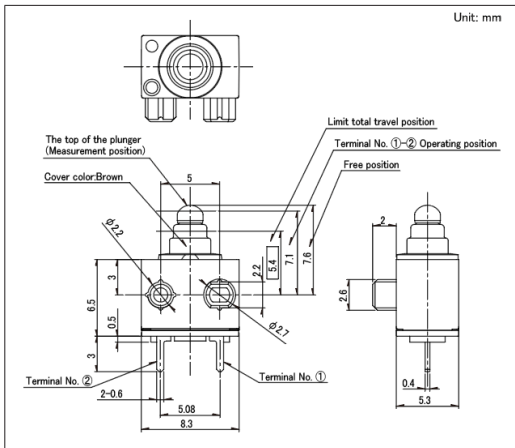

■ Circuit Diagram

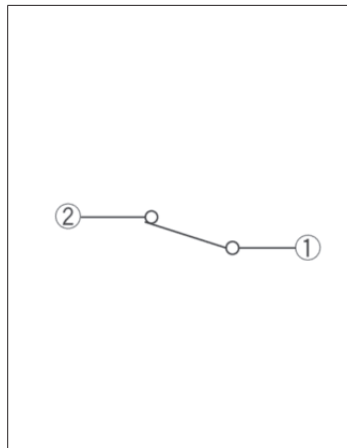

Water-proof Type
SPVQ8 Series

Drawing No.14

■ Dimensions

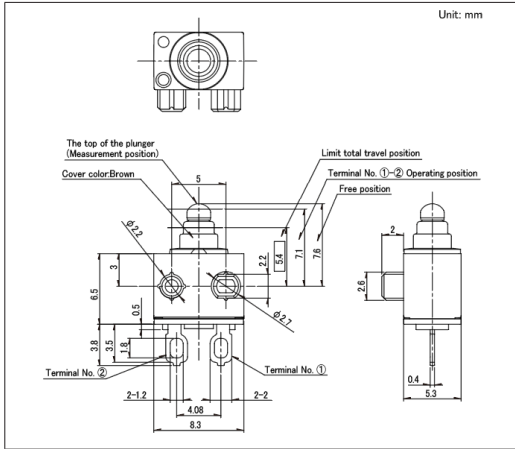

■ Circuit Diagram

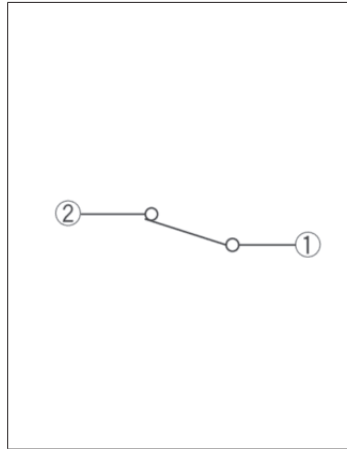

Drawing No.15

■ Dimensions

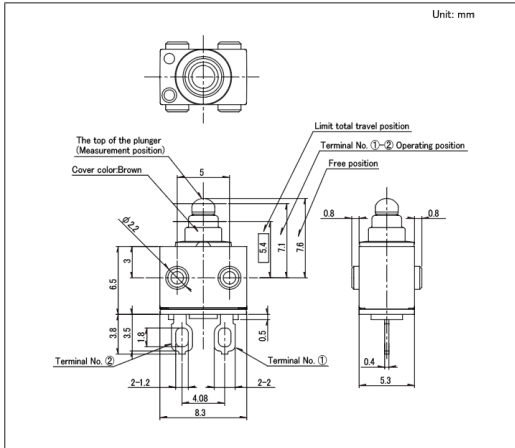

■ Circuit Diagram

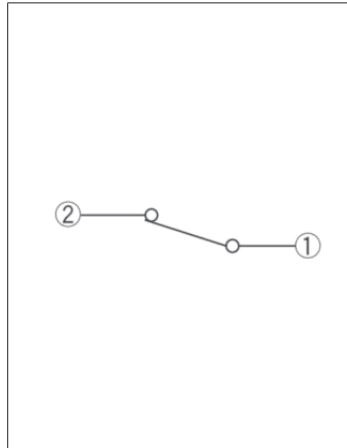

Drawing No.16

■ Dimensions

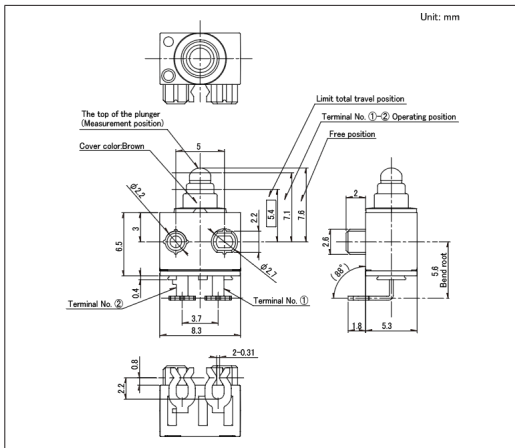

■ Circuit Diagram

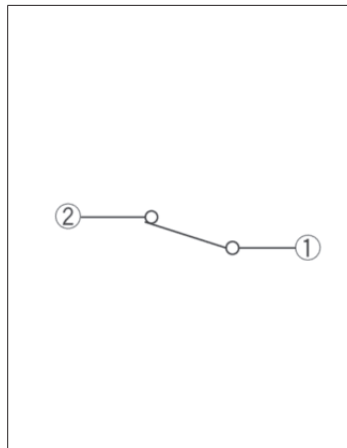

Water-proof Type
SPVQ8 Series

Drawing No.17

■ Dimensions

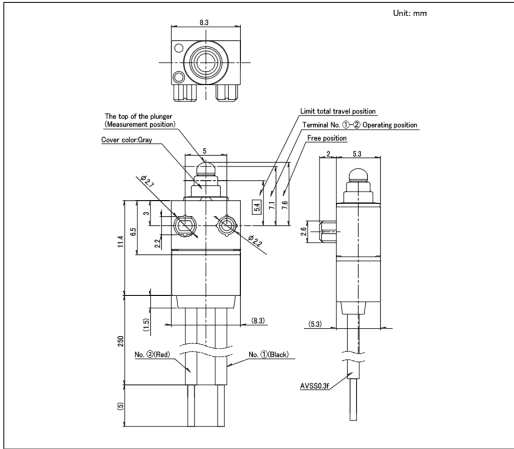

■ Circuit Diagram

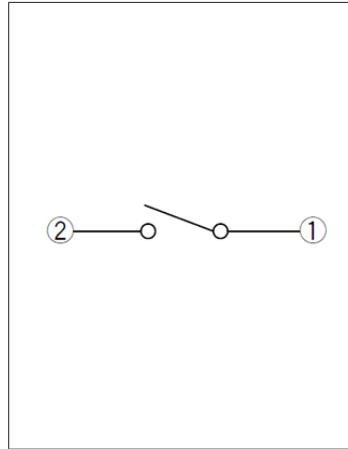

Drawing No.18

■ Dimensions

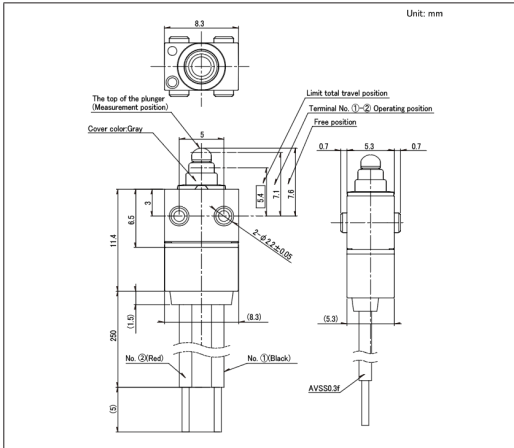

■ Circuit Diagram

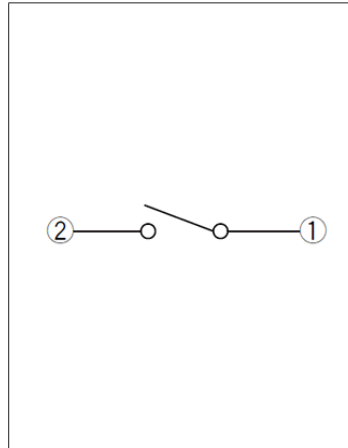

Drawing No.19

■ Dimensions

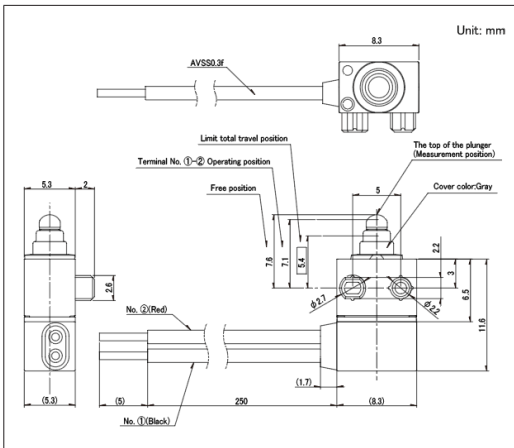

■ Circuit Diagram

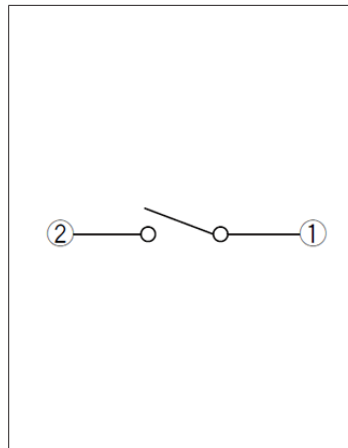

Water-proof Type
SPVQ8 Series

Drawing No.20

■ Dimensions

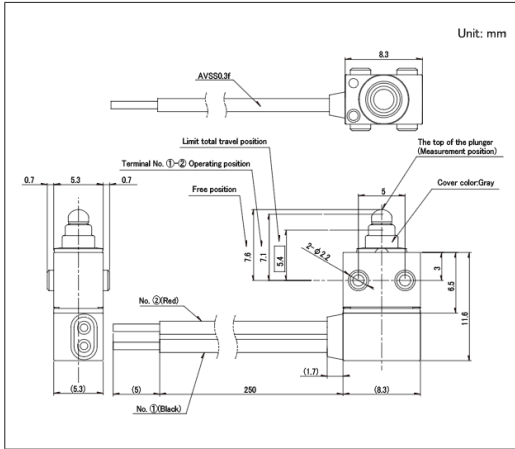

■ Circuit Diagram

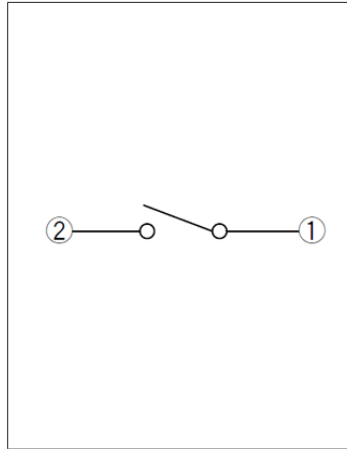

Drawing No.21

■ Dimensions

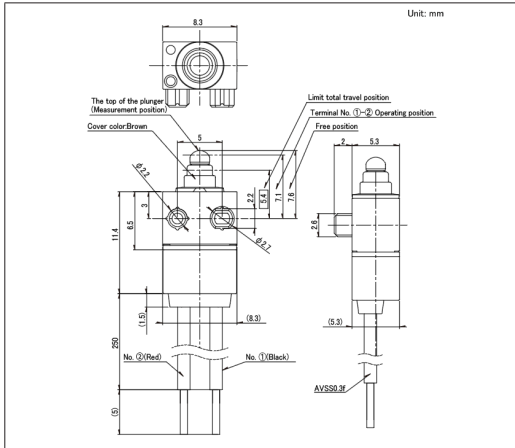

■ Circuit Diagram

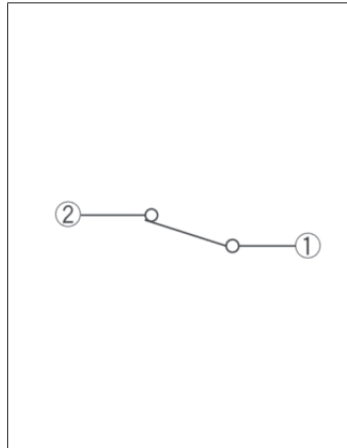

Drawing No.22

■ Dimensions

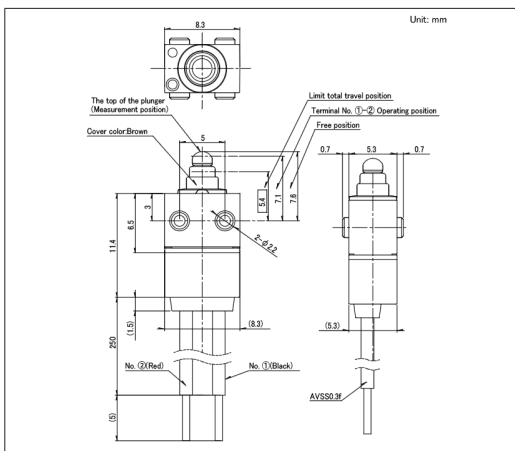

■ Circuit Diagram

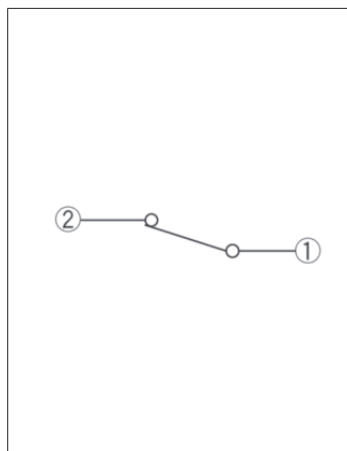

Water-proof Type
SPVQ8 Series

Drawing No.23

■ Dimensions

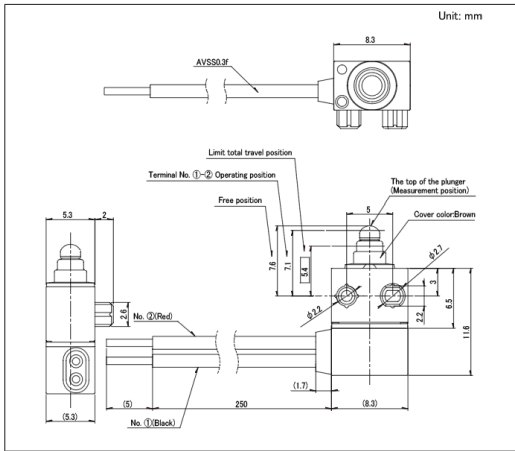

■ Circuit Diagram

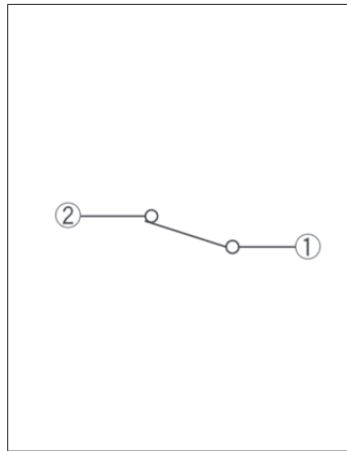

Drawing No.24

■ Dimensions

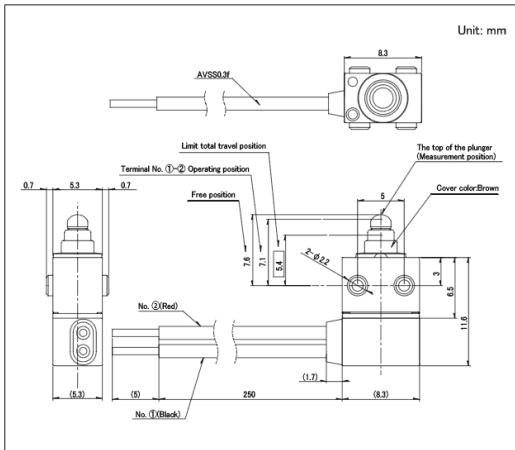

■ Circuit Diagram

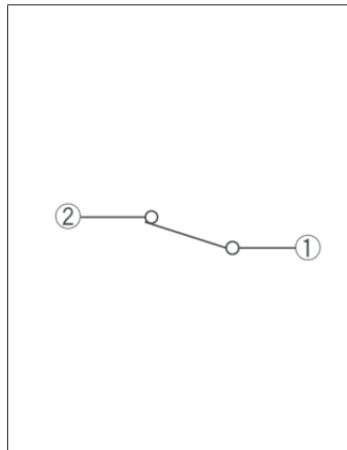

Drawing No.25

■ Dimensions

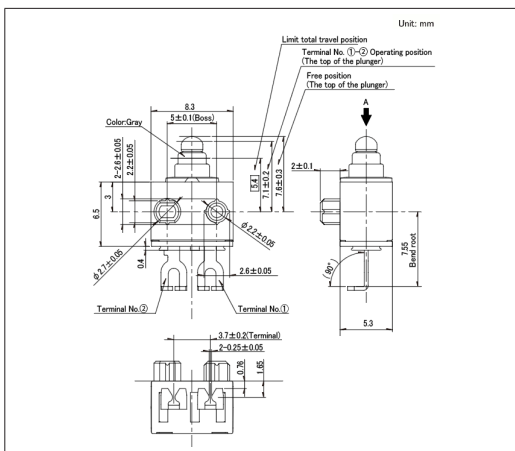

■ Circuit Diagram

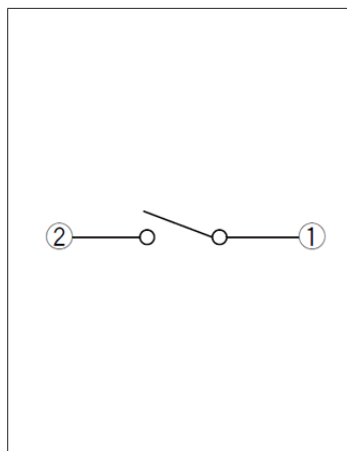

Water-proof Type SPVQ8 Series

Drawing No.26

■ Dimensions

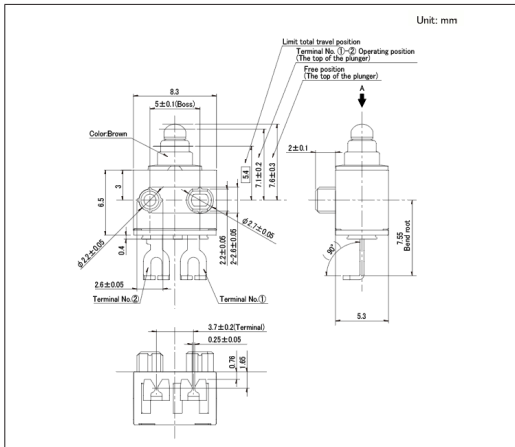

■ Circuit Diagram

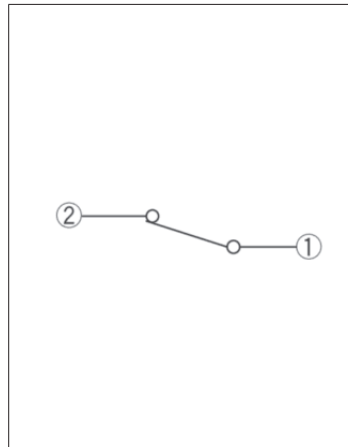

Drawing No.27

■ Dimensions

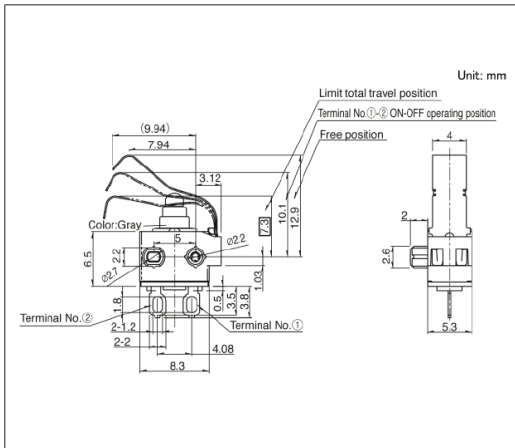

■ Circuit Diagram

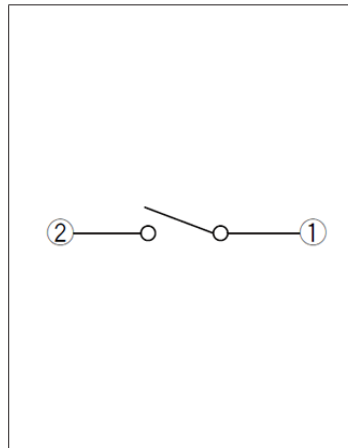

Drawing No.28

■ Dimensions

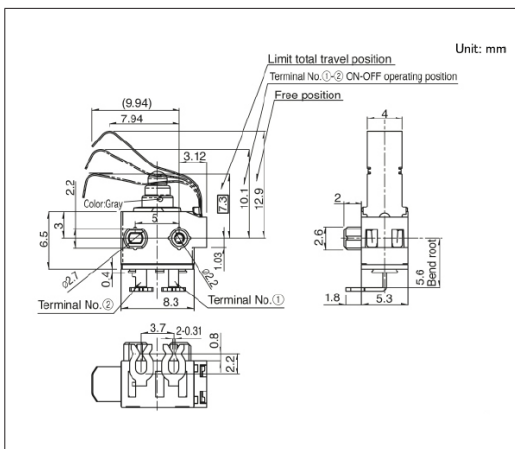

■ Circuit Diagram

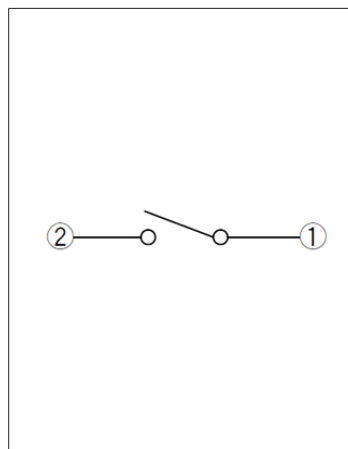

Water-proof Type
SPVQ8 Series

Drawing No.29

■ Dimensions

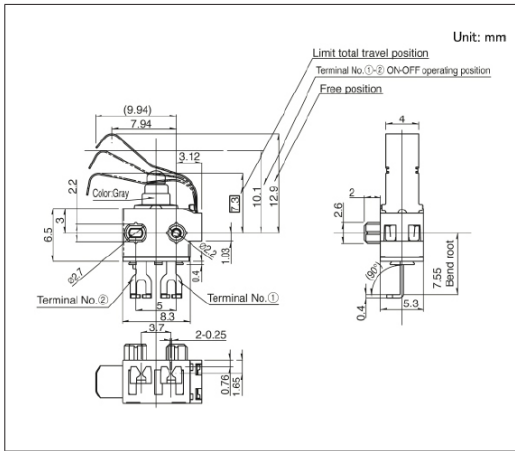

■ Circuit Diagram

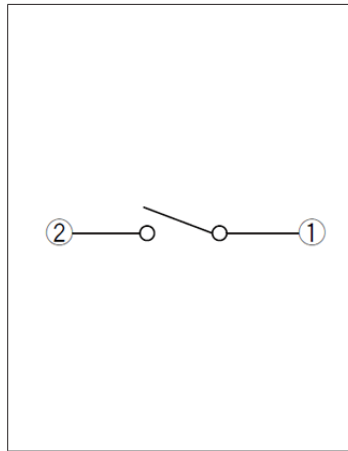

Drawing No.30

■ Dimensions

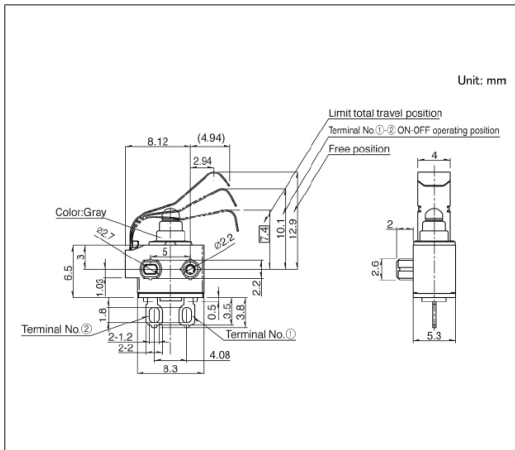

■ Circuit Diagram

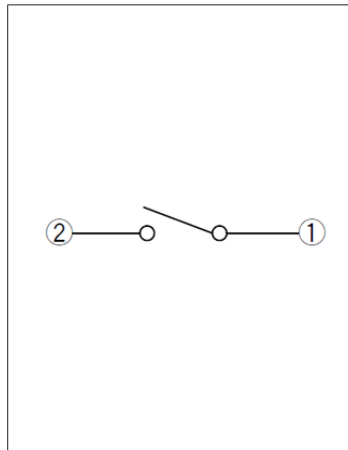

Drawing No.31

■ Dimensions

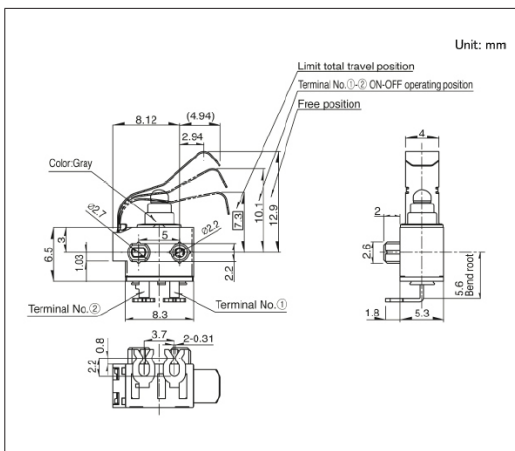

■ Circuit Diagram

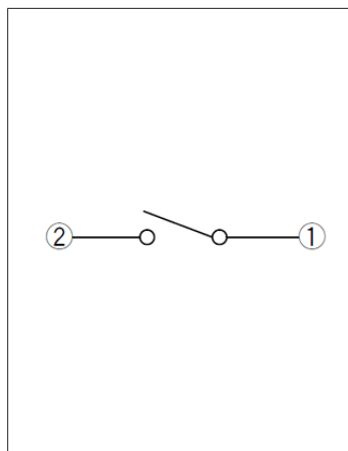

Water-proof Type
SPVQ8 Series

Drawing No.32

■ Dimensions

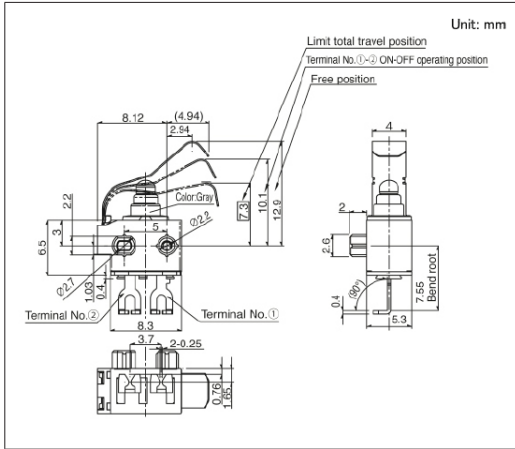

■ Circuit Diagram

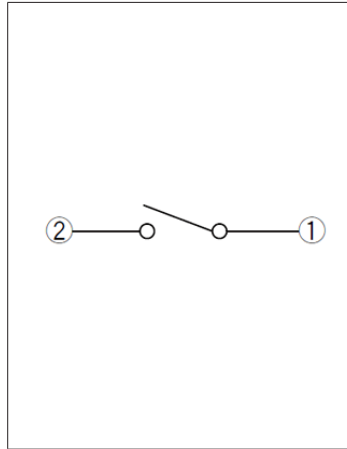

Drawing No.33

■ Dimensions

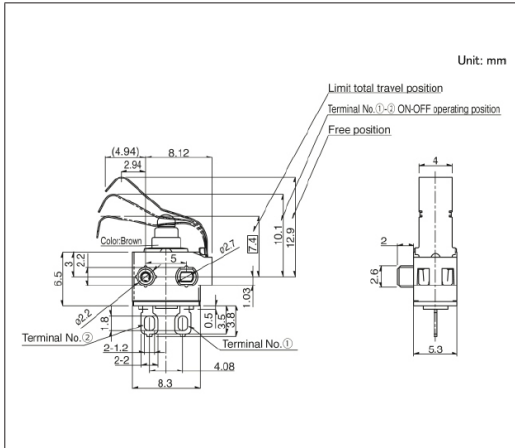

■ Circuit Diagram

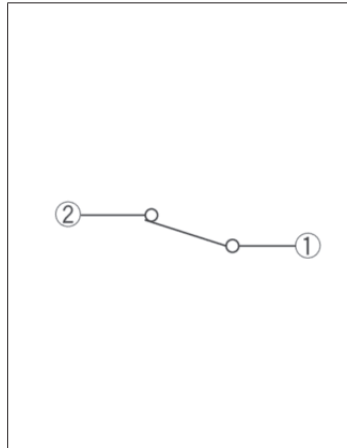

Drawing No.34

■ Dimensions

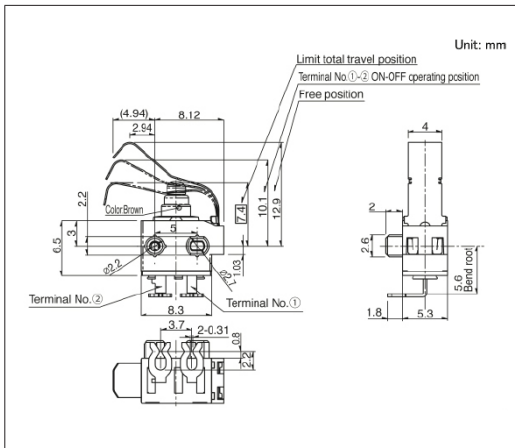

■ Circuit Diagram

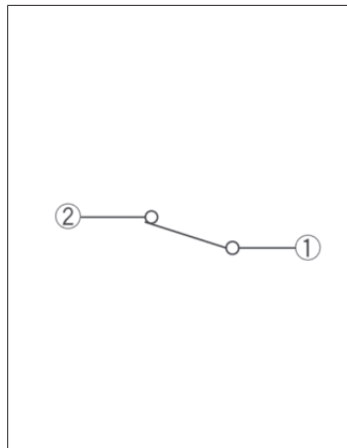

Water-proof Type
SPVQ8 Series

Drawing No.35

■ Dimensions

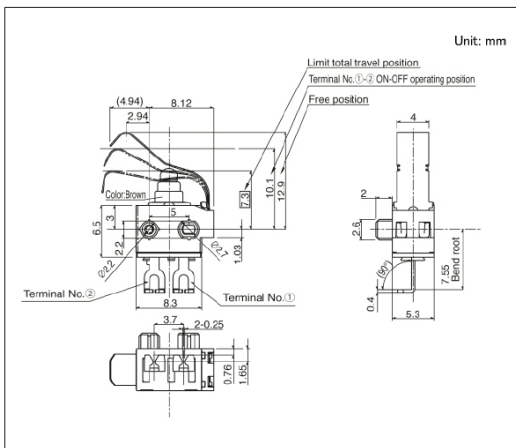

■ Circuit Diagram

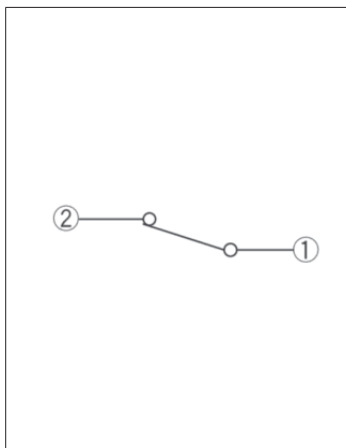

Drawing No.36

■ Dimensions

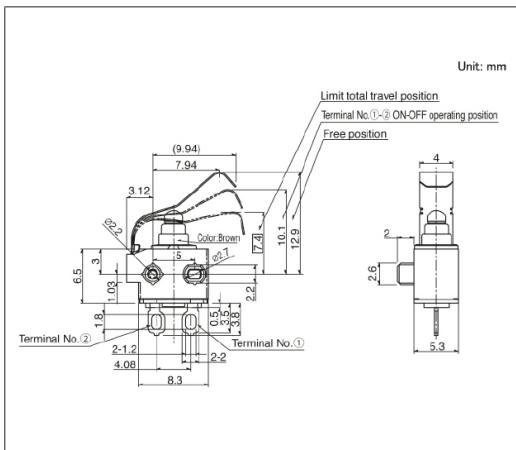

■ Circuit Diagram

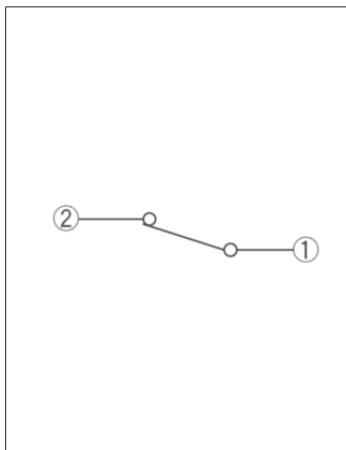

Drawing No.37

■ Dimensions

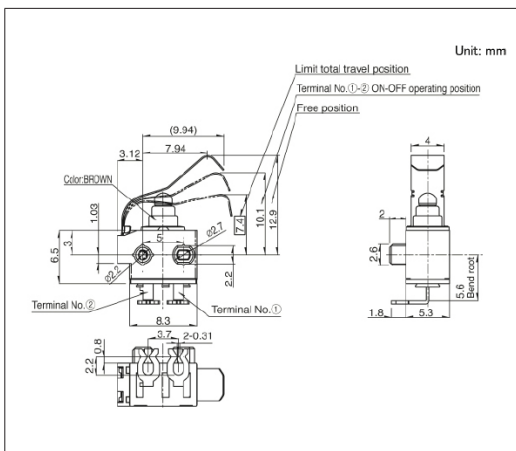

■ Circuit Diagram

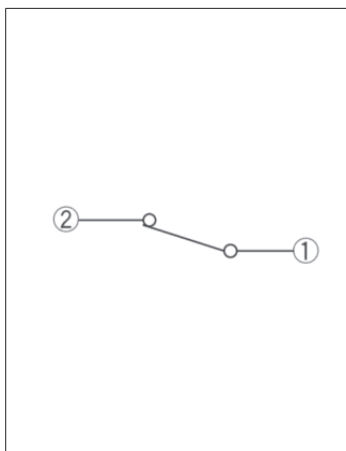

Water-proof Type
SPVQ8 Series

Drawing No.41

■ Dimensions

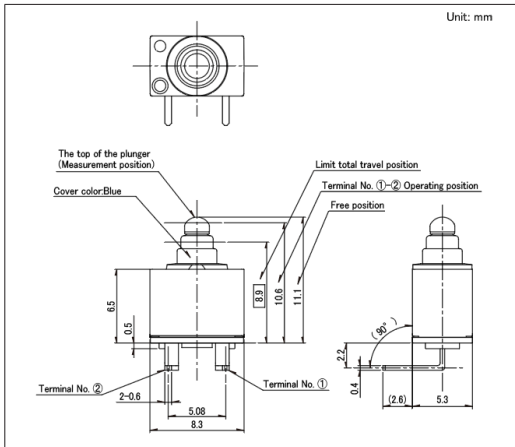

■ Circuit Diagram

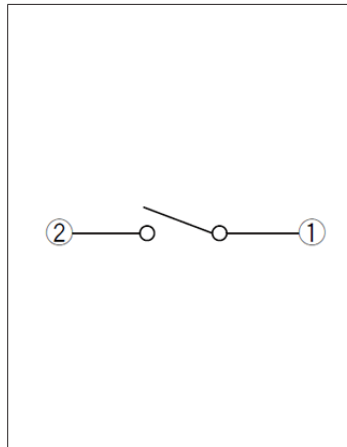

Drawing No.42

■ Dimensions

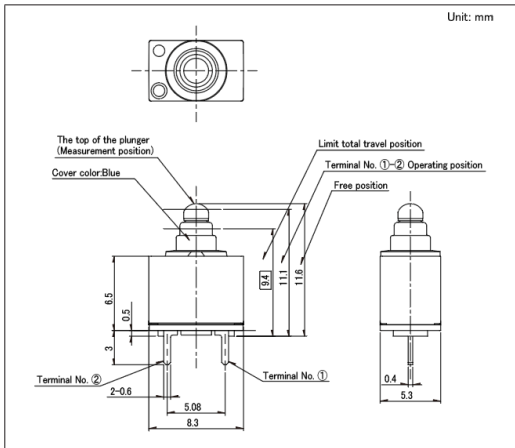

■ Circuit Diagram

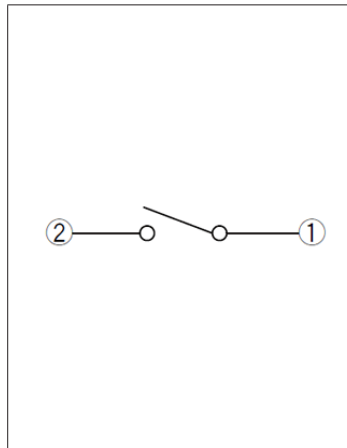

Drawing No.43

■ Dimensions

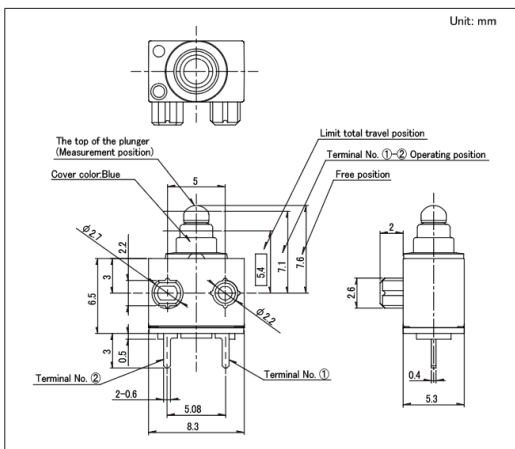

■ Circuit Diagram

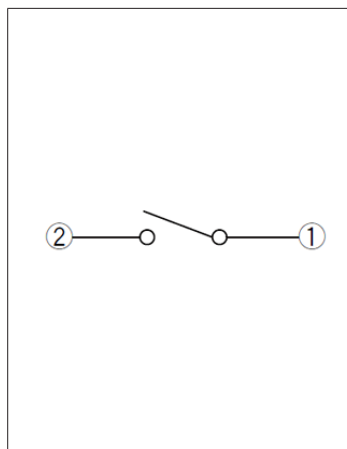

Water-proof Type
SPVQ8 Series

Drawing No.44

■ Dimensions

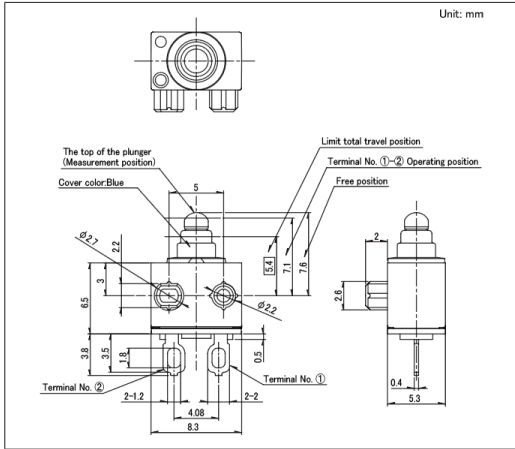

■ Circuit Diagram

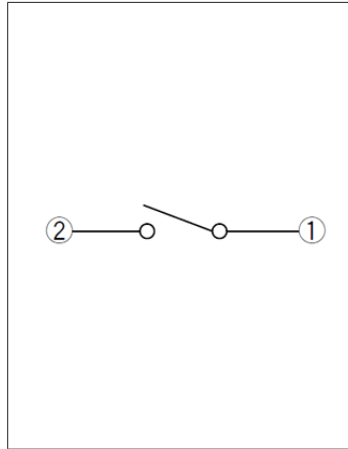

Drawing No.45

■ Dimensions

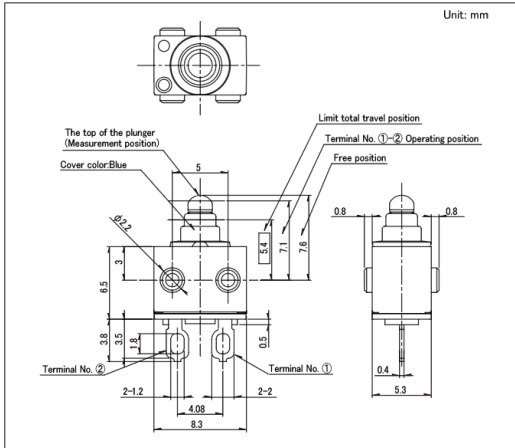

■ Circuit Diagram

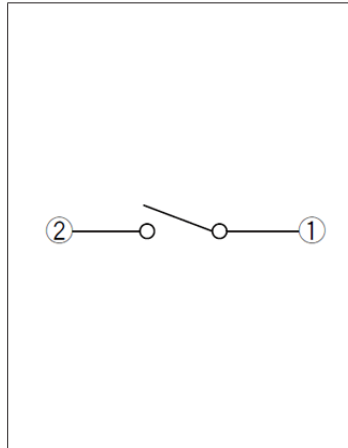

Drawing No.46

■ Dimensions

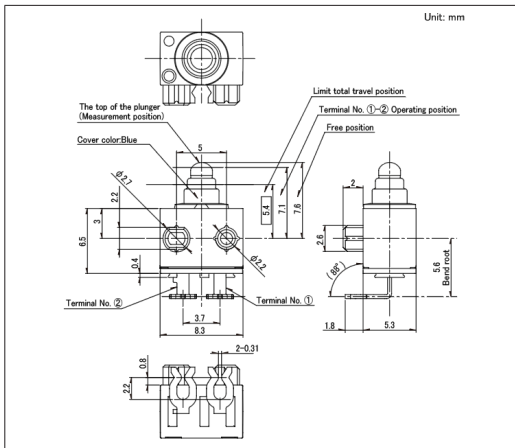

■ Circuit Diagram

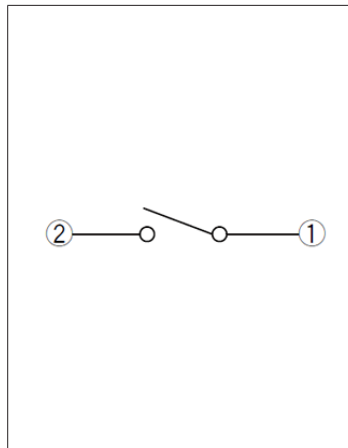

Water-proof Type
SPVQ8 Series

Drawing No.47

■ Dimensions

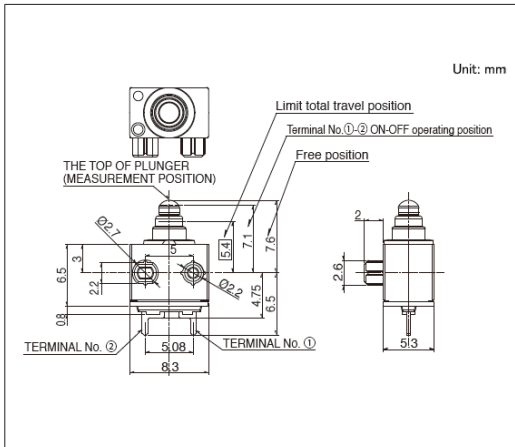

■ Circuit Diagram

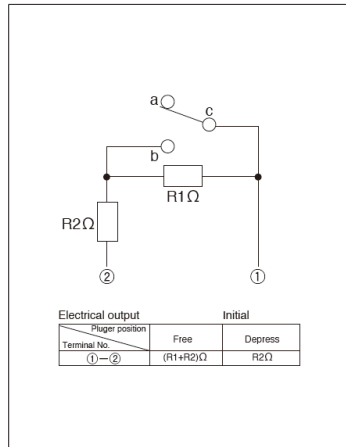

Please contact us for resistance specifications and rated power.

Drawing No.48

■ Dimensions

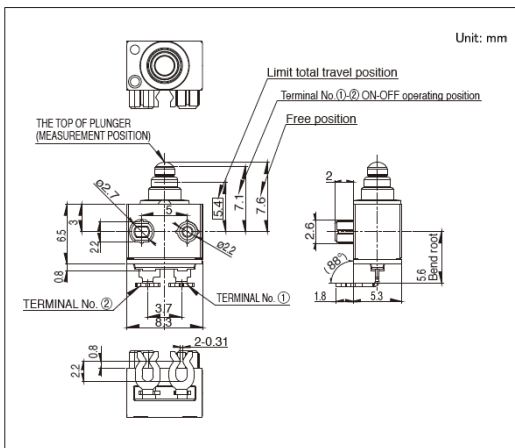

■ Circuit Diagram

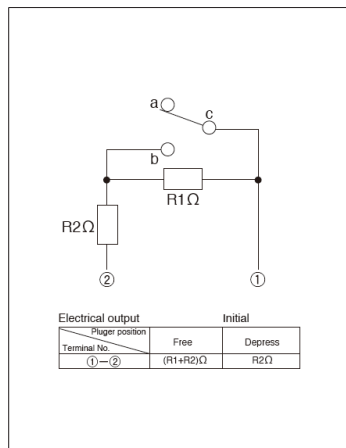

Please contact us for resistance specifications and rated power.

Drawing No.49

■ Dimensions

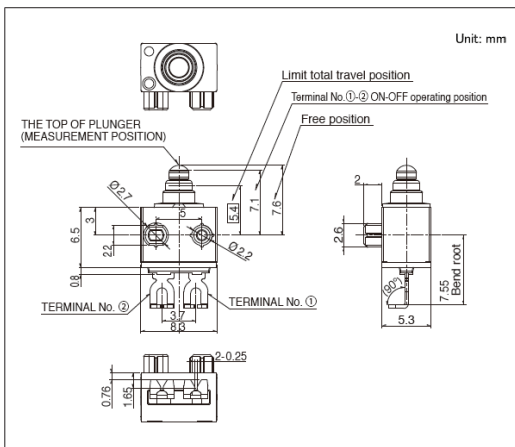

■ Circuit Diagram

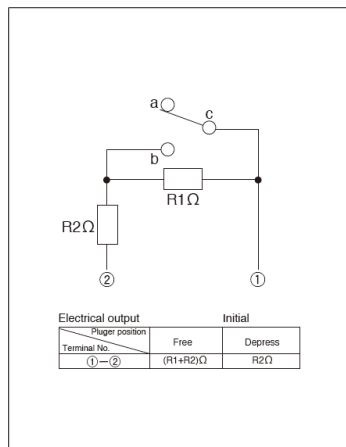

Please contact us for resistance specifications and rated power.

Switches **Detector Switches**

Water-proof Type
SPVQ8H Series

Enhanced robustness with a wire pull strength of 110N.

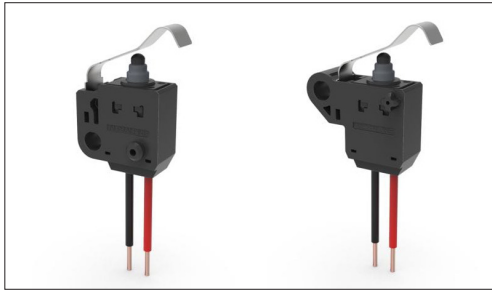

- Automotive
- Water-proof Type
- Dust-proof Type

- Rating(max.)/(min.)(Resistive load):0.1A 16V DC/50μA 5V DC
- Contact resistance(Initial/After operating life):500mΩ max./1Ω max.
- Operating life without load:100,000cycles
- Operating life with load Rating(max.)(Resistive load):
100,000cycles 1Ω max.

Applications:Energy_Industrial:Robots, drones,Industrial equipment
Home:Major home appliances
Automotive:Hood Latch (Side/Rear/Door/Gear)

■ Product List

Products No.	Poles	Positions	Operating force	Operation part shape	Terminal type	Circuit	Main body form	Dimensions (W×D×H) (mm)	Water-proof	Dust-proof	Automotive	Drawing No.
SPVQ8H0100	1	1	4.7N max.	Actuator	With wire (Downwards)	N/O	With a screw hole (Type A)	6,45×14,8×14,5	●	●	●	1
SPVQ8H0200	1	1	4.7N max.	Actuator	With wire (Downwards)	N/O	With a screw hole (Type B)	6,45×17,95×14,5	●	●	●	2

Note

1. This catalog shows only outline specifications. When using the products, please obtain formal specifications for supply.
2. Unless specified, the length of the lead wire is 250mm. Color is either red or black. For length modification, please contact us.
3. Product with wire will be build-to-order.
4. This unit cannot be used in water (IP6K7 rating, except for terminal).
5. Place your purchase order in N minimum package units (N: integer).
6. This products can be used in vehicles.
Although these products are designed to perform over a wide operating temperature range, please ensure that you receive and read the formal delivery specifications before use.

■ Packing Specifications

Bulk

Number of packages (pcs.)		Export package measurements (mm)
1 case / Japan	1 case / export packing	
300	300	360 x 360 x 290

Drawing No.1

■ Dimensions

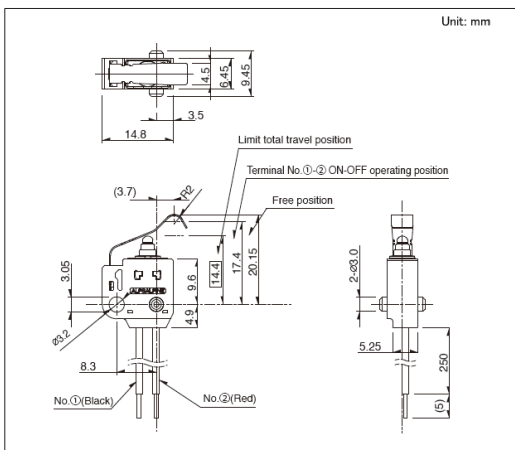

■ Circuit Diagram

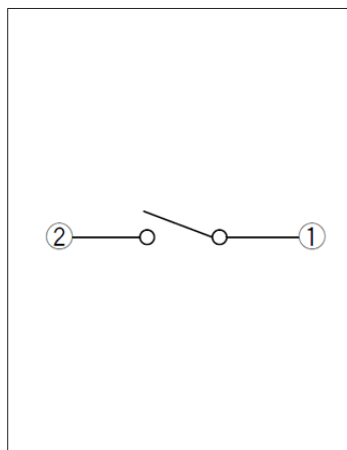

Water-proof Type
SPVQ8H Series

Drawing No.2

■ Dimensions

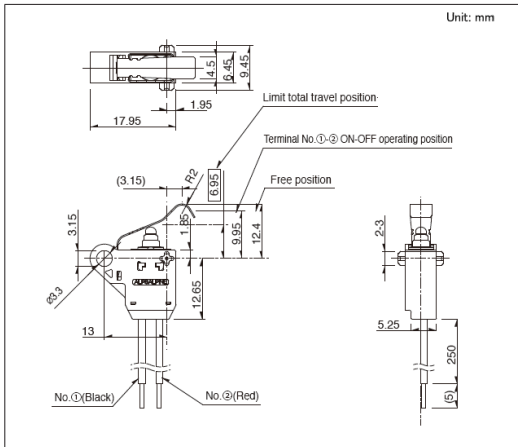

■ Circuit Diagram

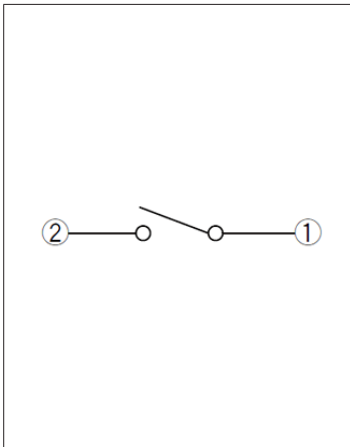

Switches

Detector Switches

Water-proof Type
SPVQ9 Series

Delivers stable contact independent of operating position or speed with a dual-circuit simultaneous switching design.



Automotive

Water-proof Type

Dust-proof Type

- Rating(max.)/(min.)(Resistive load):50mA 26V DC/50μA 5V DC
- Contact resistance(Initial/After operating life):75mΩ max./200mΩ max.
- Operating life without load:300,000 cycles
- Operating life with load Rating(max.)(Resistive load):
300,000 cycles 200mΩ max.

Applications:Home:Major home appliances
Automotive:Electric Parking Brake

Product List

Products No.	Poles	Positions	Operating force	Changeover timing	Operation part shape	Terminal type	Dimensions (W×D×H) (mm)	Water-proof	Dust-proof	Automotive	Drawing No.
SPVQ910205	2	2	1±0.5N	Non shorting	Push	For PC board	8.4×15.4×7.5	●	●	●	1

Note

1. This catalog shows only outline specifications. When using the products, please obtain formal specifications for supply.
2. This unit cannot be used in water (IP6K7 rating, except for terminal).
3. Please place purchase orders per minimum order unit (integer).
4. This products can be used in vehicles.

Although these products are designed to perform over a wide operating temperature range, please ensure that you receive and read the formal delivery specifications before use.

Packing Specifications

Tray

Number of packages (pcs.)		Export package measurements (mm)
1 case / Japan	1 case / export packing	
1,500	6,000	540 x 360 x 270

Drawing No.1

Dimensions

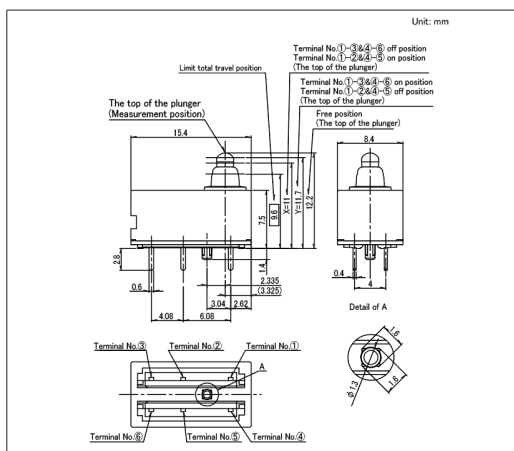

Circuit Diagram

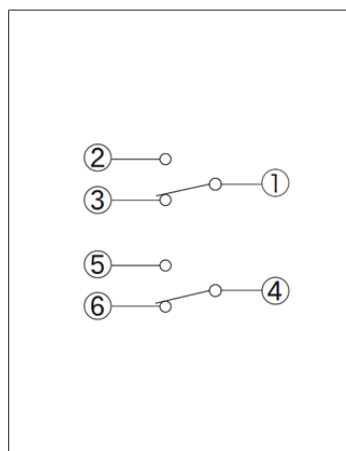

Water-proof Type SPVQA Series

Supports solderless connection with fork terminals.

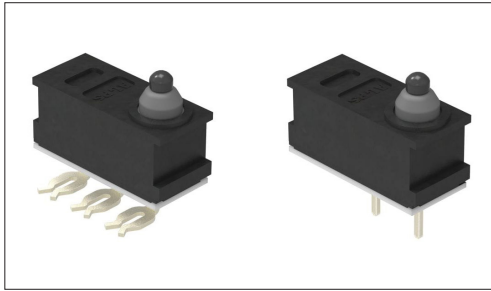

Automotive

Water-proof Type

Dust-proof Type

- Rating(max.)/(min.)(Resistive load):0.1 A 12V DC/50 μ A 5V DC
- Contact resistance(Initial/After operating life):500m Ω max./1 Ω max.
- Operating life without load:300,000 cycles
- Operating life with load Rating(max.)(Resistive load):
300,000 cycles 1 Ω max.

Applications:Home:Major home appliances
Automotive:Hood Latch (Side/Rear/Door/Gear)

Product List

Products No.	Poles	Positions	Operating force	Changeover timing	Operation part shape	Terminal type	Main body form	Dimensions (W×D×H) (mm)	Water-proof	Dust-proof	Automotive	Drawing No.
SPVQA10103	1	1	1 \pm 0.5N	Non shorting	Push	Press-fit (Without terminal No.3)	Without boss L type	6.4×15.2×7.95	●	●	●	1
SPVQA10203	1	1	1 \pm 0.5N	Non shorting	Push	Press-fit (Without terminal No.3)	Without boss R type	6.4×15.2×7.95	●	●	●	2
SPVQA10302	1	1	1 \pm 0.5N	Non shorting	Push	Press-fit (Without terminal No.2)	Without boss L type	6.4×15.2×7.95	●	●	●	3
SPVQA10402	1	1	1 \pm 0.5N	Non shorting	Push	Press-fit (Without terminal No.2)	Without boss R type	6.4×15.2×7.95	●	●	●	4
SPVQA10504	1	2	1 \pm 0.5N	Non shorting	Push	Press-fit	Without boss L type	6.4×15.2×7.95	●	●	●	5
SPVQA10604	1	2	1 \pm 0.5N	Non shorting	Push	Press-fit	Without boss R type	6.4×15.2×7.95	●	●	●	6
SPVQA20103	1	1	1 \pm 0.5N	Non shorting	Push	For PC board (Without terminal No.3)	Without boss	6.4×15.2×7.95	●	●	●	7
SPVQA20203	1	2	1 \pm 0.5N	Non shorting	Push	For PC board	Without boss	6.4×15.2×7.95	●	●	●	8

Note

1. This catalog shows only outline specifications. When using the products, please obtain formal specifications for supply.
2. This unit cannot be used in water (IP6K7 rating, except for terminal).
3. Please place purchase orders per minimum order unit (integer).
4. This products can be used in vehicles.
Although these products are designed to perform over a wide operating temperature range, please ensure that you receive and read the formal delivery specifications before use.

Packing Specifications

Tray

Number of packages(pcs.)		Export package measurements (mm)
1 case / Japan	1 case / export packing	
1,200	4,800	540 x 360 x 270

Water-proof Type
SPVQA Series

Drawing No.1

■ Dimensions

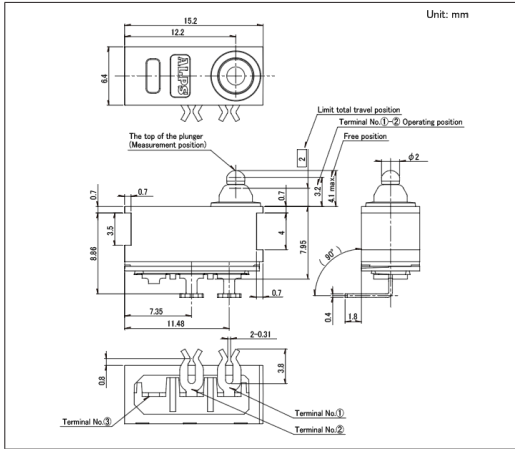

■ Circuit Diagram

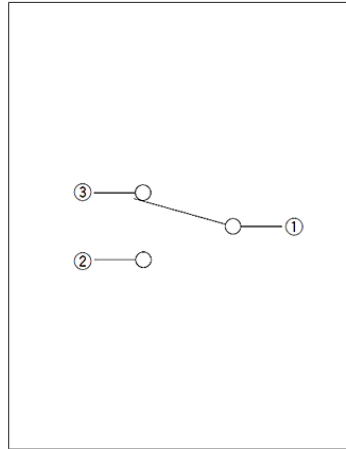

Drawing No.2

■ Dimensions

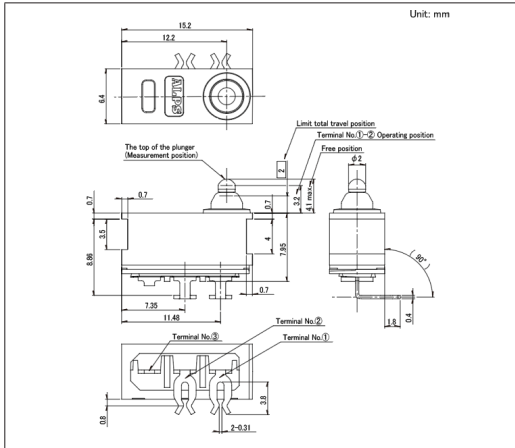

■ Circuit Diagram

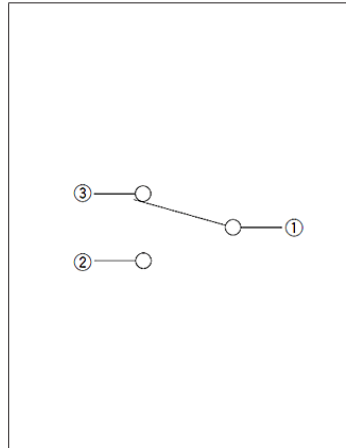

Drawing No.3

■ Dimensions

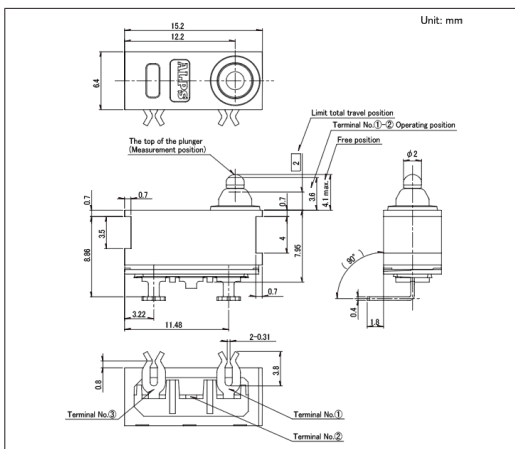

■ Circuit Diagram

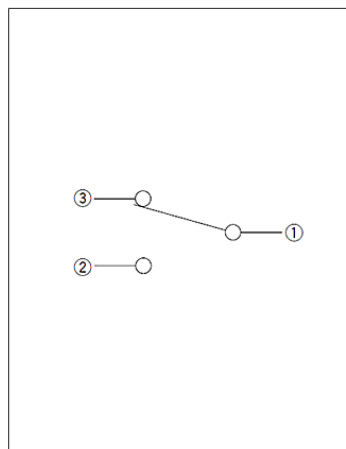

Water-proof Type
SPVQA Series

Drawing No.4

■ Dimensions

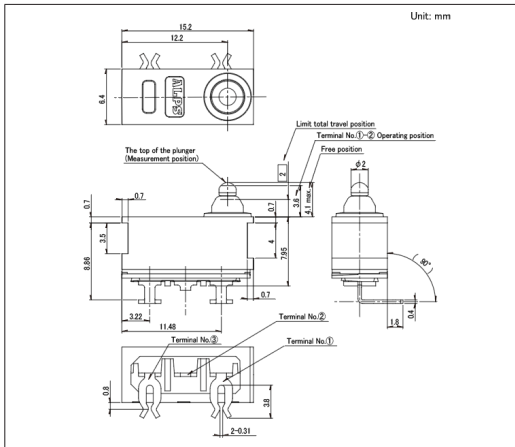

■ Circuit Diagram

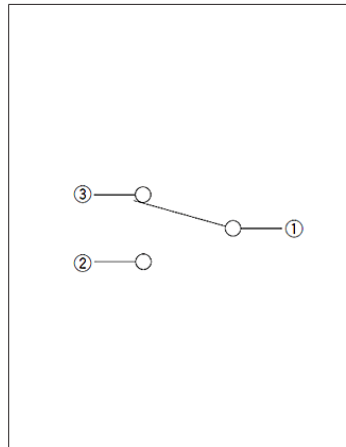

Drawing No.5

■ Dimensions

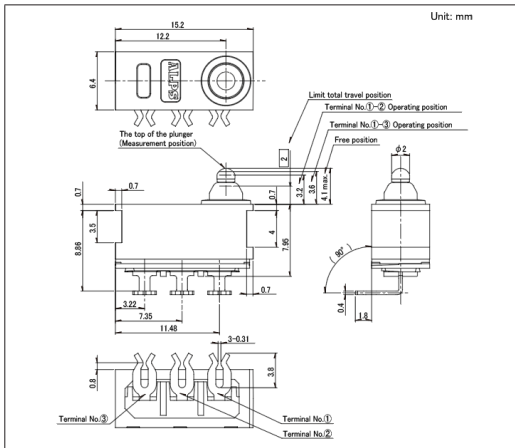

■ Recommended Unit Terminal style

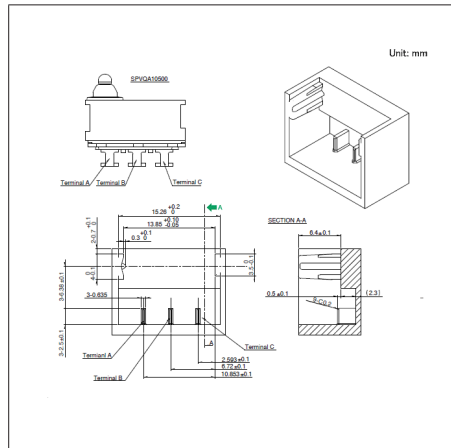

■ Circuit Diagram

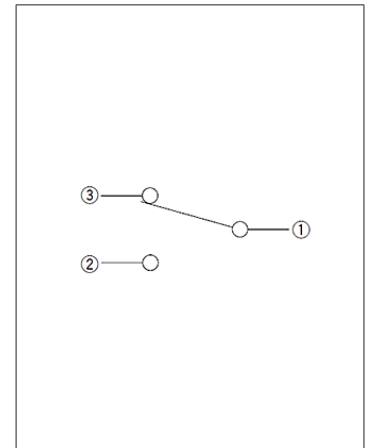

Drawing No.6

■ Dimensions

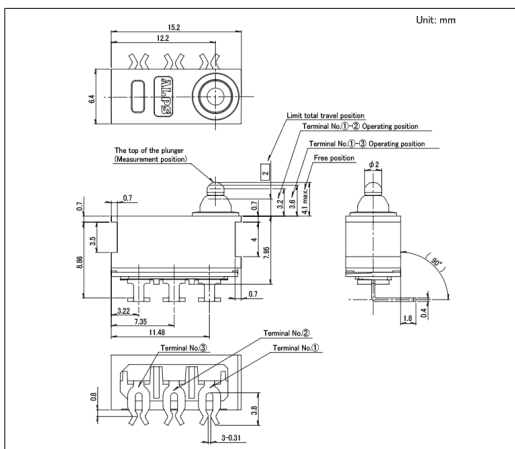

■ Circuit Diagram

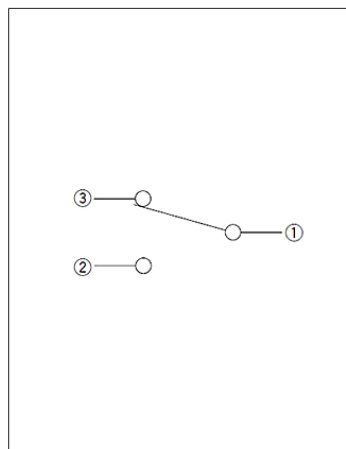

Water-proof Type
SPVQA Series

Drawing No.7

■ Dimensions

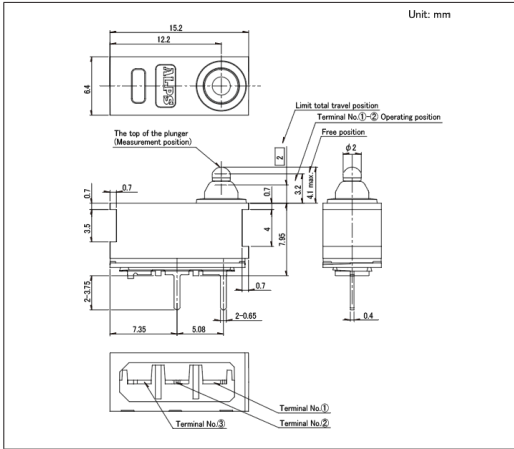

■ Circuit Diagram

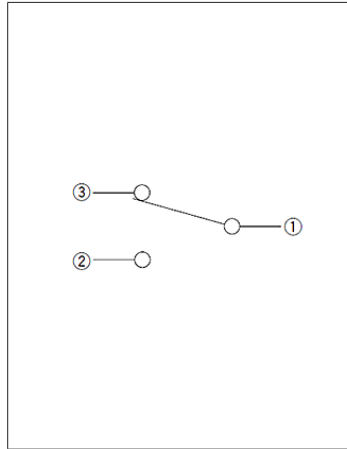

Drawing No.8

■ Dimensions

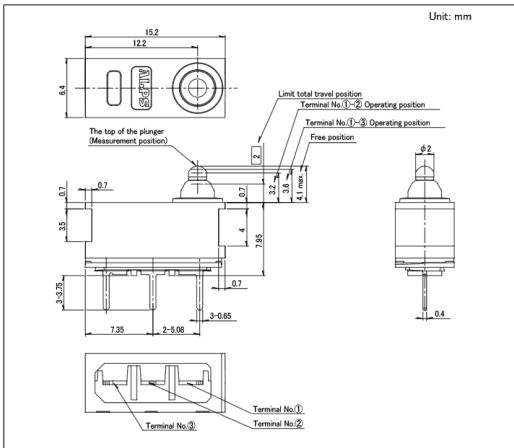

■ Circuit Diagram

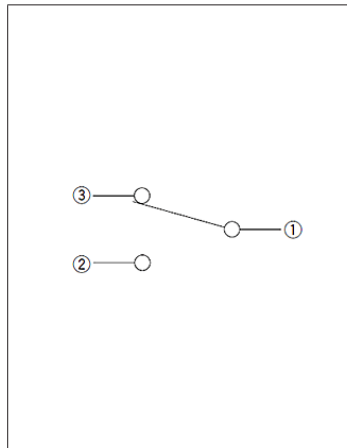

Switches **Detector Switches**

Water-proof Type (Surface Mount)
SPVQC Series

Surface-mount type with a dual-circuit simultaneous switching design ensuring stable contact.



Automotive

Water-proof Type

Dust-proof Type

- Rating(max.)/(min.)(Resistive load): 50mA 18V DC/50μA 5V DC
- Contact resistance(Initial/After operating life): 75mΩ max./200mΩ max.
- Operating life without load: 300,000 cycles
- Operating life with load Rating(max.)(Resistive load): 300,000 cycles 200mΩ max.

Applications: Automotive: Electric Parking Brake

Product List

Products No.	Poles	Positions	Operating force	Changeover timing	Operation part shape	Terminal type	Dimensions (W×D×H) (mm)	Water-proof	Dust-proof	Automotive	Drawing No.
SPVQC10201	2	2	1±0.5N	Non shorting	Push	For PC board (Reflow)	7.4×15.4×7.5	●	●	●	1

Note

1. This catalog shows only outline specifications. When using the products, please obtain formal specifications for supply.
2. This unit cannot be used in water (IP6K7 rating, except for terminal).
3. Please place purchase orders for taping products per minimum order unit (1 reel or a case).
4. This products can be used in vehicles.
Although these products are designed to perform over a wide operating temperature range, please ensure that you receive and read the formal delivery specifications before use.

Packing Specifications

Taping

Number of packages(pcs.)			Tape width (mm)	Export package measurements (mm)
1 reel	1 case / Japan	1 case / export packing		
300	1,200	2,400	32	403 x 403 x 360

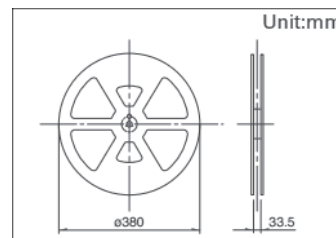

Drawing No.1

Dimensions

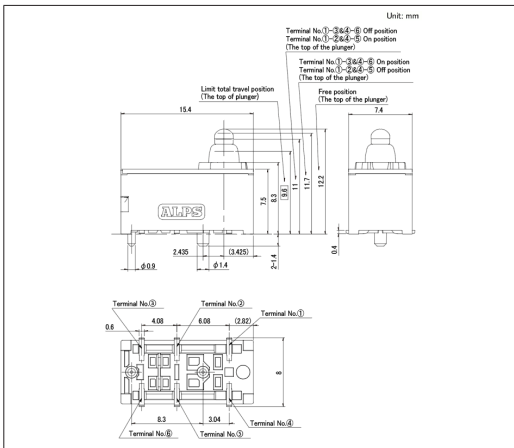

Land Dimensions

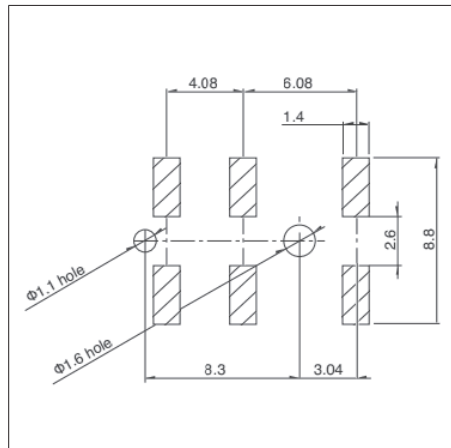

Circuit Diagram

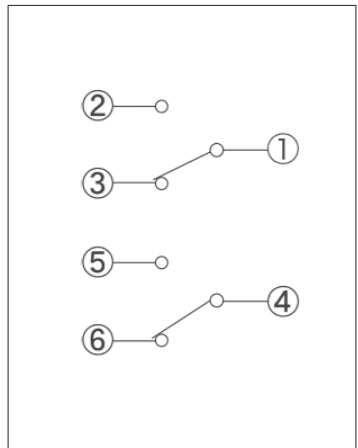

Switches **Detector Switches**

Water-proof Type (Surface Mount)
SPVQF Series

2-circuit synchronous snap action, compact and quiet type

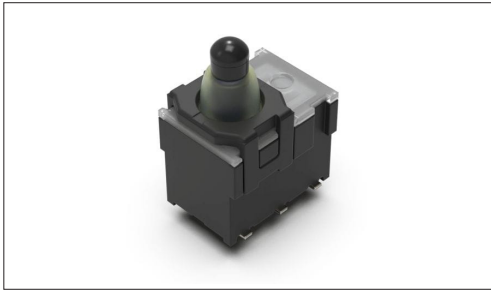

- Automotive
- Water-proof Type
- Dust-proof Type

- Rating(max.)/(min.)(Resistive load): 50mA 18V DC/50μA 5V DC
- Contact resistance(Initial/After operating life): 75mΩ max./2Ω max.
- Operating life without load: 300,000 cycles
- Operating life with load Rating(max.)(Resistive load): 300,000 cycles 2Ω max.

Applications: Automotive: Electric Parking Brake

■ Product List

Products No.	Poles	Positions	Operating force	Changeover timing	Operation part shape	Terminal type	Dimensions (W×D×H) (mm)	Water-proof	Dust-proof	Automotive	Drawing No.
SPVQF10201	2	2	1.8N max.	Non shorting	Push	For PC board (Reflow)	6.3×8.5×7.0	●	●	●	1

Note

1. This catalog shows only outline specifications. When using the products, please obtain formal specifications for supply.
2. This unit cannot be used in water (IP6K7 rating, except for terminal).
3. Please place purchase orders for taping products per minimum order unit (1 reel or a case).
4. This products can be used in vehicles.

Although these products are designed to perform over a wide operating temperature range, please ensure that you receive and read the formal delivery specifications before use.

■ Packing Specifications

Taping

Number of packages(pcs.)			Tape width (mm)	Export package measurements (mm)
1 reel	1 case / Japan	1 case / export packing		
400	800	1,600	24	428 x 413 x 172

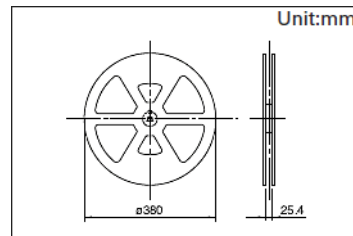

Drawing No.1

■ Dimensions

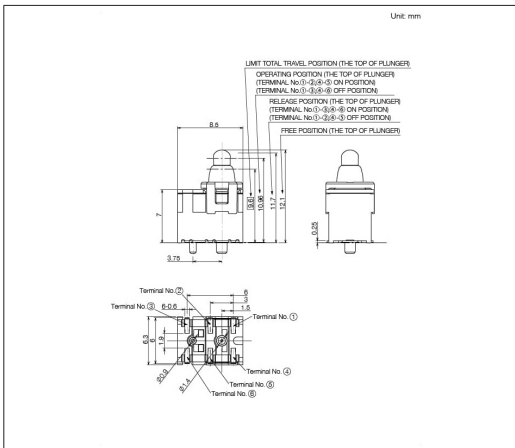

■ Land Dimensions

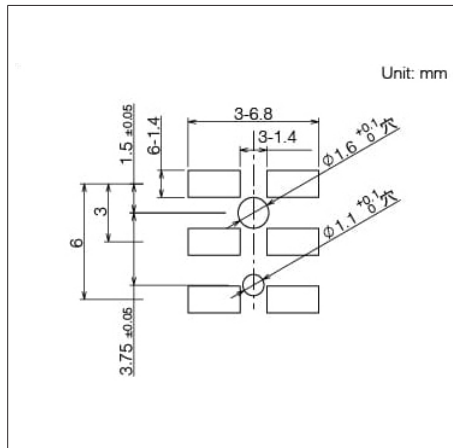

■ Circuit Diagram

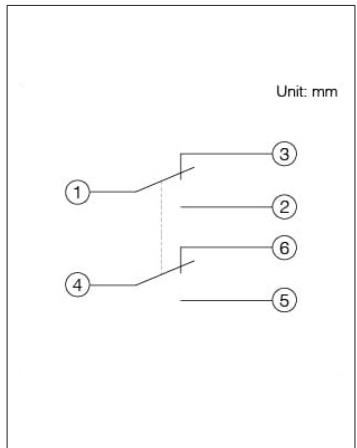

Switches **Detector Switches**

Water-proof Lever Type
SSCN Series

Water-proof lever switch capable of left-right detection with a 40° operating angle per side.

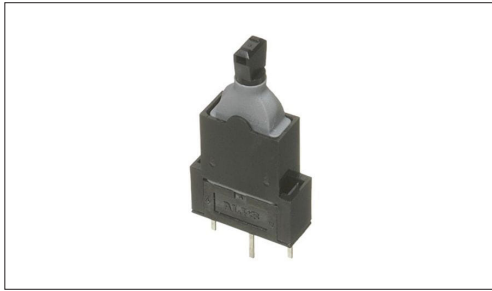

Automotive **Water-proof Type** **Dust-proof Type**

- Rating(max.)/(min.)(Resistive load):0.1A 12V DC/100μA 5V DC
- Contact resistance(Initial/After operating life):500mΩ max./1Ω max.
- Operating life without load:100,000 cycles
- Operating life with load Rating(max.)(Resistive load):
100,000 cycles 1Ω max.

Applications:Energy_Industrial:Robots, drones,Industrial equipment
Home:Major home appliances
Automotive:Hood Latch (Side/Rear/Door/Gear)

■ Product List

Products No.	Poles	Positions	Operating force	Changeover timing	Terminal type	Dimensions (W×D×H) (mm)	Water-proof	Dust-proof	Automotive	Drawing No.
SSCN110101	1	2	2N max.	Non shorting	For PC board	5.0×13.0×15.0	●	●	●	1

Note

1. This catalog shows only outline specifications. When using the products, please obtain formal specifications for supply.
2. This unit cannot be used in water (IP6K7 rating, except for terminal).
3. Please place purchase orders per minimum order unit (integer).
4. This products can be used in vehicles.
Although these products are designed to perform over a wide operating temperature range, please ensure that you receive and read the formal delivery specifications before use.

■ Packing Specifications

Tray

Number of packages (pcs.)		Export package measurements (mm)
1 case / Japan	1 case / export packing	
600	2,400	540 x 360 x 270

Drawing No.1

■ Dimensions

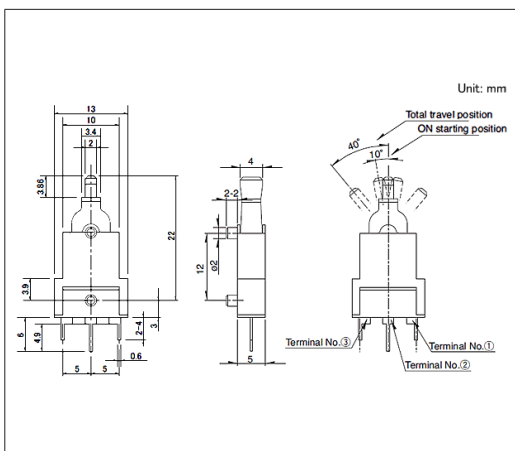

■ Circuit Diagram

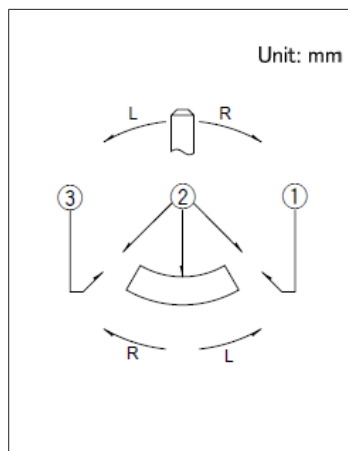

Switches **Detector Switches**

Water-proof Switch Compatible with 10mA to 4.5A
SDDH Series

Compliant with IP6K8 waterproofing standards, enabling submerged operation.

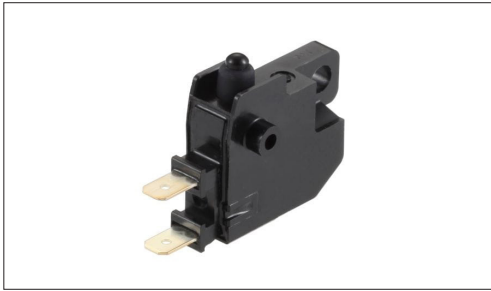

- Automotive
- Water-proof Type
- Dust-proof Type

- Rating(max.)/(min.)(Resistive load):4.5A 12V DC/10mA 12V DC
- Contact resistance(Initial/After operating life):500mΩ max./1Ω max.
- Operating life without load:100,000 cycles
- Operating life with load Rating(max.)(Resistive load):
 100,000 cycles 1Ω max.

Applications:Automotive:Motorcycles

■ Product List

Products No.	Poles	Positions	Operating force	Terminal type	Circuit	Dimensions (W×D×H) (mm)	Water-proof	Dust-proof	Automotive	Drawing No.
SDDHA10100	1	1	4.6N max.	Snap-in Tab Terminal (#187)	SPST (normally closed)	28.5×9.0×24.3	●	●	●	1

Note

1. This catalog shows only outline specifications. When using the products, please obtain formal specifications for supply.
2. Please place purchase orders per minimum order unit (integer).
3. This products can be used in vehicles.
 Although these products are designed to perform over a wide operating temperature range, please ensure that you receive and read the formal delivery specifications before use.

■ Packing Specifications

Tray

Number of packages (pcs.)		Export package measurements (mm)
1 case / Japan	1 case / export packing	
180	360	400 x 270 x 185

Drawing No. 1

■ Dimensions

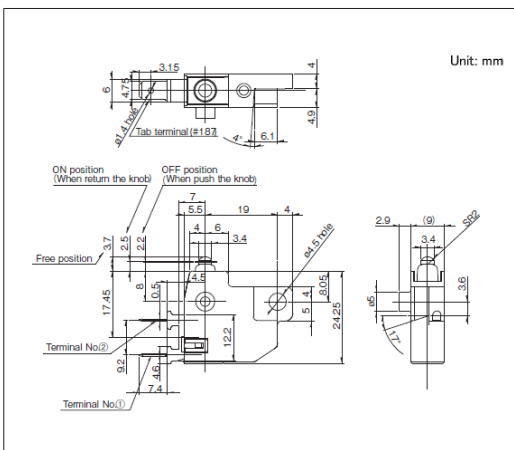

■ Circuit Diagram

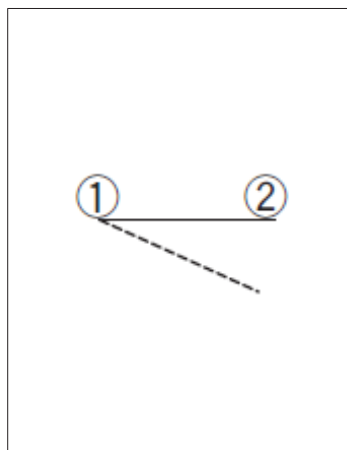

Detector Switches / Soldering Conditions

■ Example of Reflow Soldering Condition

1. Heating method: Double heating method with infrared heater.
2. Temperature measurement: Thermocouple $\phi 0.1$ to 0.2 CA(K) or CC(T) at soldering portion (copper foil surface).
A heat resisting tape should be used for fixed measurement.
3. Temperature profile

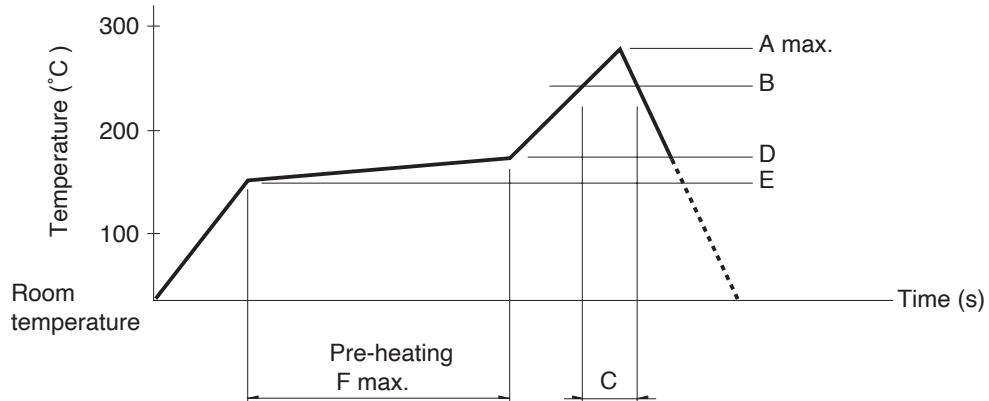

Series (Reflow type)	A (°C) 3s max.	B (°C)	C (s)	D (°C)	E (°C)	F (s)
SPPB	250	230	40	180	150	120
SPVE	260					
SPVL						
SPVM						
SPVN						
SPVR						
SPVS						
SPVT						
SSCM						
SSCQ						
SPVQC	250					
SPVQF						

⚠ Note

1. The condition mentioned above is the temperature on the mounting surface of a PC board. There are cases where the PC board's temperature greatly differs from that of the switch, surface depending on the PC board's material, size, thickness, etc.
The above-stated conditions shall also apply to switch surface temperatures.
2. Soldering conditions differ depending on reflow soldering machines.
Prior verification of soldering condition is highly recommended.

■ Reference for Hand Soldering

Series	Soldering temperature	Soldering time
SPVS, SPVN, SPVT, SPVM, SPVR, SPVE, SSCQ, SSCM, SPVL, SSCT, SPVQC, SPVQF	350±5°C	3s max.
SPVQ3, SPVQ6, SPVQ7, SPVQ8, SPVQ9, SSCN, SPVQA	300±10°C	3+1/0s
SPPB (Reflow)	300±5°C	5s max.
SSCF, SPPB (For Lead, Dip)	350±10°C	3+1/0s

■ Reference for Dip Soldering

(For PC board terminal types)

Series	Items		Dip soldering	
	Preheating temperature	Preheating time	Soldering temperature	Duration of immersion
SSCT, SPVQ3, SPVQ6, SPVQ7, SPVQ8, SPVQ9, SPVQA	100±10°C	60s max.	260±5°C	5±1s
SPPW8, SPPB	100 °C max.	60s max.	255±5°C	5±1s
SSCF	—		260±5°C	5±1s







Detector Switches / Cautions

1. Applying load to terminals during soldering under certain conditions may cause deformation and electrical property degradation.
2. Avoid use of water-soluble soldering flux, since it may corrode the switches.
3. Check and conform to soldering requirements under actual mass production conditions.
4. No washing.
5. The products are designed and manufactured for direct current resistance. Contact us for use of other resistances such as inductive (L) or capacitive (C).
6. The circuit setting (software setting) shall be ensured for error-free operations, caused by bounce and chattering as specified by each model of the switches.
7. Do not use the switches for a long time near the upper or lower limits of the specified operating temperatures. The use environments shall satisfy the specified range of the environmental tests in the specifications.
8. In case of continuous operation near the upper and lower limits, see requirements of each model to check if possible.
9. The switches designed specifically for automotive uses can be used for vehicles. No other switches shall be used for vehicles.
10. Use the switches sufficiently distant (i.e. at a position closer to the full distance) from the ON Start Position.
11. The switch-returning force cannot be used as a mechanical driving force of a set.
12. Do not apply transverse force to the operating part while piling up PC boards in process and during transportation.
13. Protect small and thin switches from external forces in the set mounting process.
14. Use of a through-hole PC board, or a PC board of different thickness from the recommendation will have a different heat stress. Verify the soldering requirements thoroughly before use.
15. Warped PC boards may change their properties. Carefully design and lay-out the patterns.
16. Use of thinner PC boards will require extra care, since the switches may be floated.
17. Use of the switches in a dusty environment may lead the dusts entering through the openings and cause imperfect contact or malfunction. Take this into account for set design.
18. Corrosive gas if generated by peripheral parts of a set, malfunction such as imperfect contact may occur. Thorough investigation shall be required beforehand.
19. Storage
Store the products as delivered at normal temperature and humidity, out of direct sunlight and away from corrosive gases. Use them as soon as possible and no later than six months after delivery.
Once the seal is broken, use them as soon as possible.

Switches

Slide Switches

List of Varieties

Series		SSAJ	SSSS8	SSAG	SSSS7	SSSS2	SSSS9	SSSF	
Photo									
Actuator directions	Horizontal	●	●	●	●	●	●	●	
	Vertical	—	●	—	—	●	●	●	
Dimensions (mm)		2.5×5.5×0.7	6.7×2.6×1.4 6.7×4.1×1.4 9.7×2.6×1.4 9.7×4.1×1.4	3.0×9.05×1.15	8.8×3.0×2.0 12.5×3.0×2.0	8.5×3.5×3.5 9.0×3.5×3.5 13.0×3.5×3.5 15.0×3.5×3.5	11.5×4.7×5.0 11.5×4.7×5.5 11.5×7.2×5.0 11.5×7.2×5.5 14.0×4.7×5.5 14.0×7.2×5.0 14.0×7.2×5.5	14.5×7.0×8.5 16.5×7.0×8.5	
Poles		1	1 2	1	1	1	2	1 2 4	
Positions		2	2 3	3	2 3	2 3 4	2 3	2 3	
Operating force		1.5±1N	Refer to the dimensions	1N (Recoil side) 1N (Recoil side), 1.5N (Lock side)	Refer to the dimensions.		3±1.5N a, c → b 2±1N b → a, c 3±1.5N	Refer to the dimensions.	
Operating temperature range		-10°C to +60°C	-40°C to +85°C	-10°C to +60°C	-40°C to +85°C				
Rating (max.)/(min.) (Resistive load)		10mA 5V DC/ 50μA 3V DC	0.3A 5V DC/ 50μA 3V DC	10mA 5V DC/ 50μA 3V DC	0.3A 4V DC/ 50μA 3V DC	0.3A 6V DC/ 50μA 3V DC	0.1A 12V DC/ 1mA 5V DC	0.1A 30V DC/ 50μA 3V DC	
Electrical performance	Contact resistance (Initial performance/ After lifetime)	300mΩ max./ 500mΩ max.	70mΩ max./ 130mΩ max.	200mΩ max./ 500mΩ max.	70mΩ max./ 130mΩ max.		30mΩ max./ 80mΩ max.	25mΩ max./ 65mΩ max.	
	Insulation resistance	100MΩ min. 100V DC				100MΩ min. 500V DC			
	Voltage proof	100V AC for 1 minute				500V AC for 1 minute			
Mechanical performance	Terminal strength		3N for 1 minute					5N for 1 minute	
	Actuator strength	Operating direction	10N			20N	30N		
		Pulling direction	10N						30N
Durability	Operating life without load	10,000 cycles 500mΩ max.	10,000 cycles 100mΩ max.	100,000 cycles 500mΩ max. 100,000 cycles 500mΩ max. (Recoil side) 30,000 cycles 500mΩ max. (Lock side)	10,000 cycles 100mΩ max.	100 cycles 100mΩ max. 10,000 cycles 100mΩ max.	10,000 cycles 60mΩ max.	10,000 cycles 45mΩ max.	
	Operating life with load (at max. rated load)	10,000 cycles 500mΩ max.	10,000 cycles 130mΩ max.	100,000 cycles 500mΩ max. 100,000 cycles 500mΩ max. (Recoil side) 30,000 cycles 500mΩ max. (Lock side)	10,000 cycles 130mΩ max.	100 cycles 130mΩ max. 10,000 cycles 130mΩ max.	10,000 cycles 80mΩ max.	10,000 cycles 65mΩ max.	
Environmental performance	Cold	-40°C 96h	-40°C 500h	-40°C 96h	-40°C 500h				
	Dry heat	85°C 96h	85°C 500h	85°C 96h	85°C 500h				
	Damp heat	40°C, 90 to 95%RH 96h	60°C, 90 to 95%RH 500h	40°C, 90 to 95%RH 96h	60°C, 90 to 95%RH 500h				
Automotive		—	—	—	—	—	—	—	



● Indicates applicability to all products in the series, while ○ indicates applicability to some products in the series.

Slide Switches

Series		SSSU	
Photo			
Actuator directions	Horizontal	●	
	Vertical	●	
Dimensions (mm)		18.5×7.0×8.5 21.5×7.0×8.5 24.5×7.0×8.5	
Poles		1 2 4	
Positions		2 3	
Operating force		Refer to the dimensions.	
Operating temperature range		-40°C to +85°C	
Rating (max.)/(min.) (Resistive load)		0.1A 30V DC/ 50μA 3V DC	
Electrical performance	Contact resistance (Initial performance/ After lifetime)	25mΩ max./ 65mΩ max.	
	Insulation resistance	100MΩ min. 500V DC	
	Voltage proof	500V AC for 1 minute	
Mechanical performance	Terminal strength	5N for 1 minute	
	Actuator strength	Operating direction	30N
		Pulling direction	30N
Durability	Operating life without load	10,000 cycles 45mΩ max.	
	Operating life with load (at max. rated load)	10,000 cycles 65mΩ max.	
Environmental performance	Cold	-40°C 500h	
	Dry heat	85°C 500h	
	Damp heat	60°C, 90 to 95%RH 500h	
Automotive		—	

 Note

● Indicates applicability to all products in the series, while ○ indicates applicability to some products in the series.

Switches

Slide Switches

0.7mm (H), 1.4mm-travel (Surface Mount)

SSAJ Series

Compact type with a body height of 0.7mm.

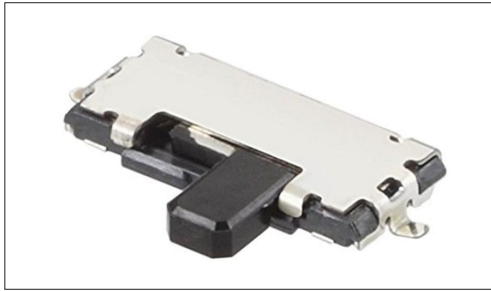

- Rating (max.)/(min.) (Resistive load): 10mA 5V DC/50 μ A 3V DC
- Contact resistance (Initial performance/After lifetime):
300m Ω max./500m Ω max.
- Operating life without load: 10,000 cycles 500m Ω max.
- Operating life with load (at max. rated load): 10,000 cycles 500m Ω max.

Applications: Mobile: Smartphones, tablets, Headsets, wearables,
Notebooks, peripherals
Energy_Industrial: Robots, drones, Industrial equipment,
Converters
Game: Home handheld consoles, Virtual/augmented reality
Healthcare: Healthcare equipment, Nursing care equipment,
Analysis, test equipment
Audio_TV: Audio, Cameras

■ Product List

Products No.	Actuator directions	Travel (mm)	Poles	Positions	Operating force	Changeover timing	Soldering	Location lug	Dimensions (W×D×H) (mm)	Automotive	Drawing No.
SSAJ110100	Horizontal	1.4	1	2	1.5±1N	Not specified	Reflow	With	2.5×5.5×0.7	—	1
SSAJ120100	Horizontal	1.4	1	2	1.5±1N	Not specified	Reflow	Without	2.5×5.5×0.7	—	2

⚠ Note

1. This catalog shows only outline specifications. When using the products, please obtain formal specifications for supply.
2. Please place purchase orders for taping products per minimum order unit (1 reel or a case).

■ Packing Specifications

Taping

Number of packages (pcs.)			Tape width (mm)	Export package measurements (mm)
1 reel	1 case / Japan	1 case / export packing		
5,000	10,000	20,000	16	417 x 409 x 139

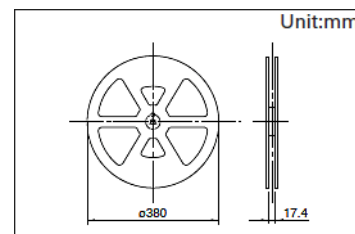

Drawing No.1

■ Dimensions

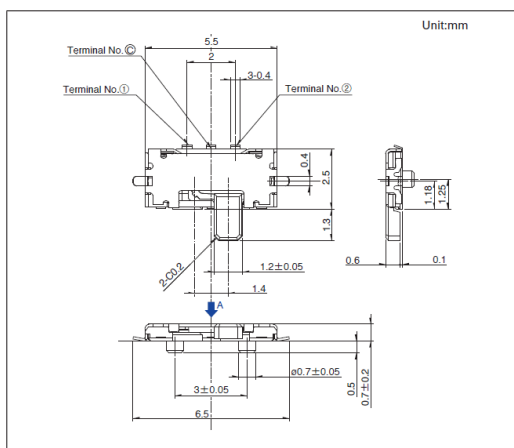

■ Land Dimensions

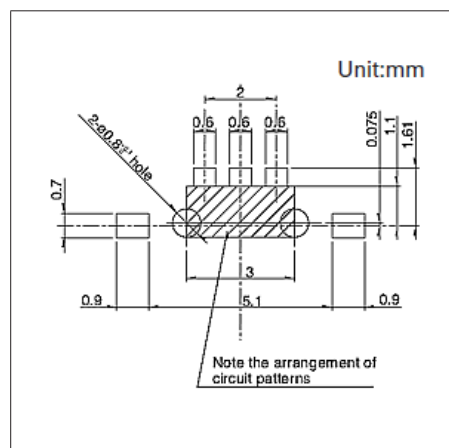

■ Circuit Diagram

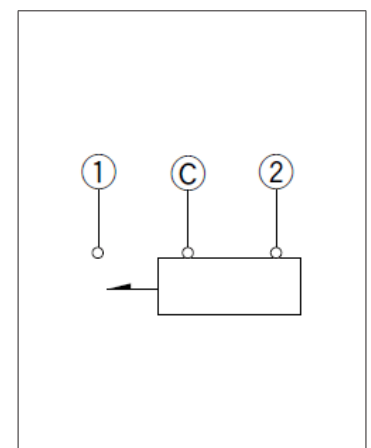

0.7mm (H), 1.4mm-travel (Surface Mount)
SSAJ Series

Drawing No.2

■ Dimensions

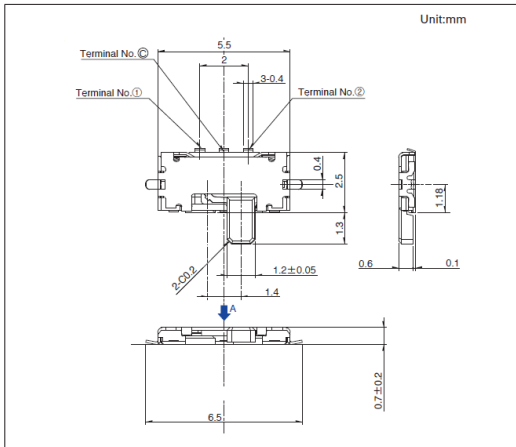

■ Land Dimensions

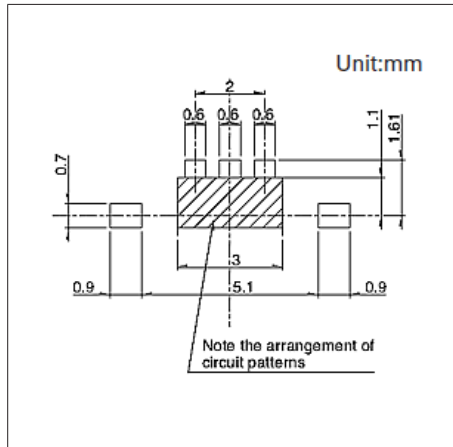

■ Circuit Diagram

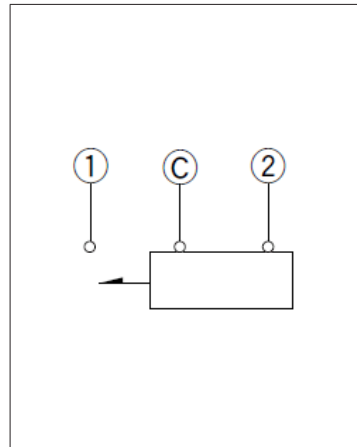

Switches

Slide Switches

1.4 (H) mm, 1.5/2.0mm-travel (Surface Mount)

SSSS8 Series

Thin-profile type with a body height of 1.4mm.

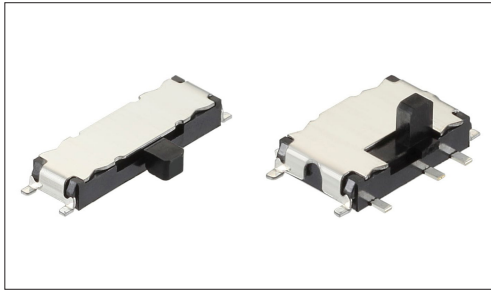

- Rating (max.)/(min.) (Resistive load): 0.3A 5V DC/50 μ A 3V DC
- Contact resistance (Initial performance/After lifetime):
70m Ω max./130m Ω max.
- Operating life without load: 10,000 cycles 100m Ω max.
- Operating life with load (at max. rated load): 10,000 cycles 130m Ω max.

Applications: Mobile: Smartphones, tablets, Headsets, wearables,
Notebooks, peripherals
Energy_Industrial: Robots, drones, Industrial equipment,
Converters
Game: Home handheld consoles, Virtual/augmented reality
Healthcare: Healthcare equipment, Nursing care equipment,
Analysis, test equipment
Audio_TV: Audio, Cameras

■ Product List

Products No.	Actuator directions	Travel (mm)	Poles	Positions	Operating force	Changeover timing	Ground terminal	Soldering	Dimensions (WxDxH) (mm)	Automotive	Drawing No.
SSSS820101	Vertical	1.5	2	2	Refer to the dimensions	Not specified	Without	Reflow	6.7×4.1×1.4	—	1
SSSS820301	Vertical	1.5	2	3	Refer to the dimensions	Not specified	Without	Reflow	9.7×4.1×1.4	—	2
SSSS820201	Vertical	1.5	2	2	Refer to the dimensions	Not specified	With	Reflow	6.7×4.1×1.4	—	3
SSSS820501	Vertical	1.5	2	3	Refer to the dimensions	Not specified	With	Reflow	9.7×4.1×1.4	—	4
SSSS810701	Horizontal	1.5	1	2	Refer to the dimensions	Not specified	Without	Reflow	6.7×2.6×1.4	—	5
SSSS811501	Horizontal	1.5	1	3	Refer to the dimensions	Not specified	Without	Reflow	9.7×2.6×1.4	—	6
SSSS811101	Horizontal	1.5	1	2	Refer to the dimensions	Not specified	With	Reflow	6.7×2.6×1.4	—	7
SSSS812201	Horizontal	1.5	1	3	Refer to the dimensions	Not specified	With	Reflow	9.7×2.6×1.4	—	8
SSSS810201	Horizontal	2.0	1	2	Refer to the dimensions	Not specified	With	Reflow	9.7×2.6×1.4	—	9

⚠ Note

1. This catalog shows only outline specifications. When using the products, please obtain formal specifications for supply.
2. Please place purchase orders for taping products per minimum order unit (1 reel or a case).

■ Packing Specifications

Taping

Products No.	Number of packages(pcs.)			Tape width (mm)	Export package measurements (mm)
	1 reel	1 case / Japan	1 case / export packing		
SSSS820101 SSSS820301 SSSS820201 SSSS820501	1,800	3,600	7,200	24	406 x 406 x 190
SSSS810701 SSSS811501 SSSS811101 SSSS812201 SSSS810201	4,500	9,000	18,000	16	417 x 409 x 139

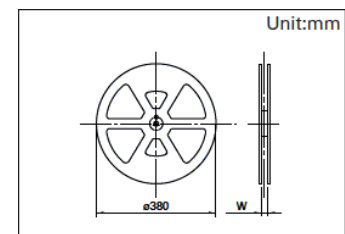

1.4 (H) mm, 1.5/2.0mm-travel (Surface Mount)
SSSS8 Series

Drawing No.1

■ Dimensions

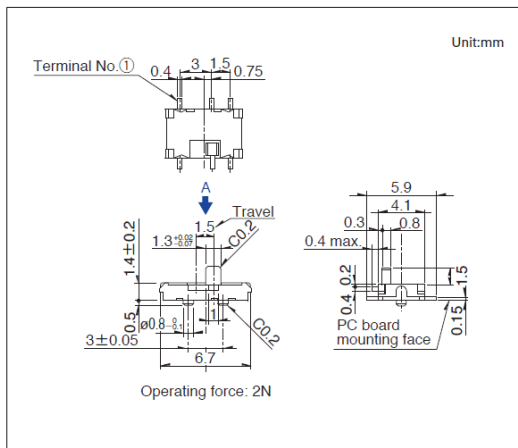

■ Land Dimensions

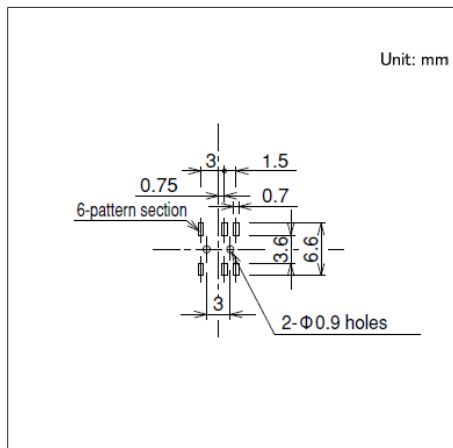

■ Circuit Diagram

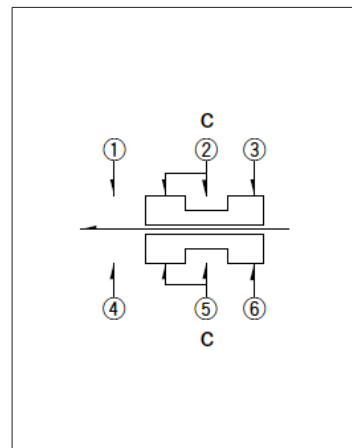

Viewed from direction A in the dimensions.

Drawing No.2

■ Dimensions

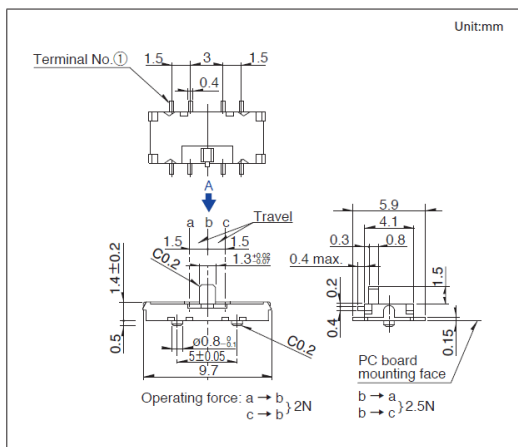

■ Land Dimensions

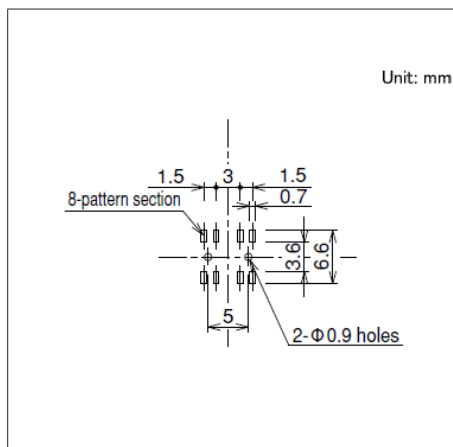

■ Circuit Diagram

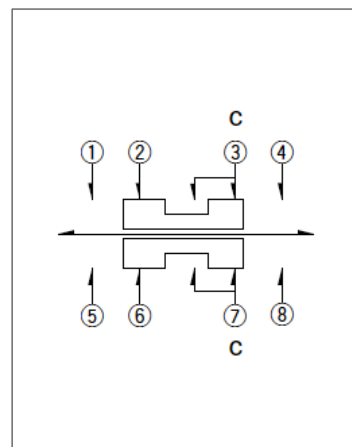

Viewed from direction A in the dimensions.

Drawing No.3

■ Dimensions

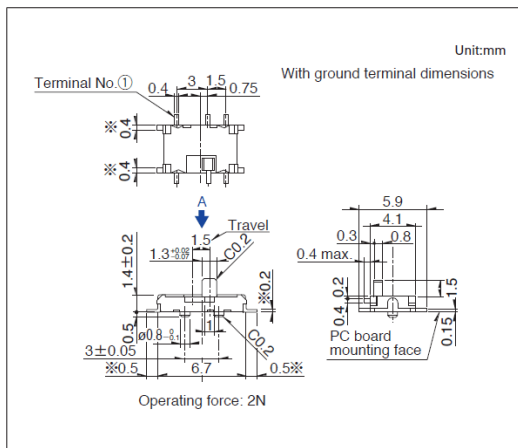

■ Land Dimensions

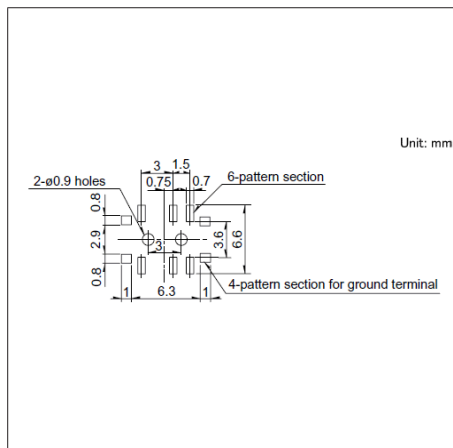

■ Circuit Diagram

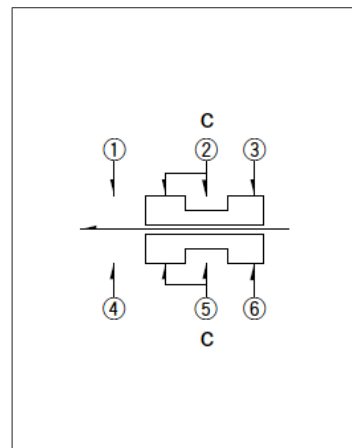

Viewed from direction A in the dimensions.

Switches Slide Switches

1.4 (H) mm, 1.5/2.0mm-travel (Surface Mount)
SSSS8 Series

Drawing No.4

■ Dimensions

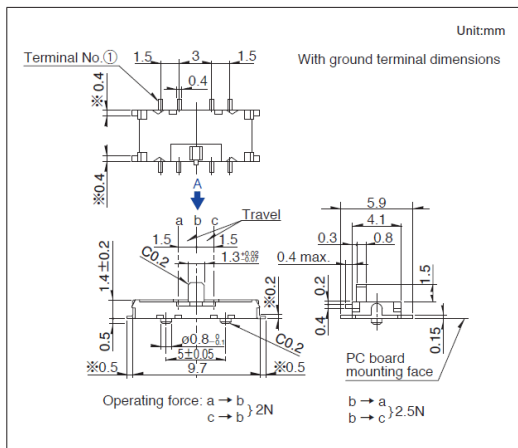

■ Land Dimensions

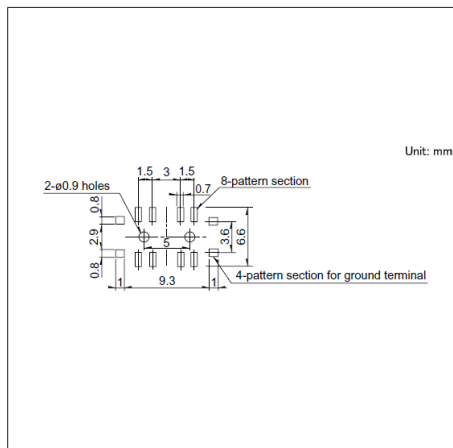

■ Circuit Diagram

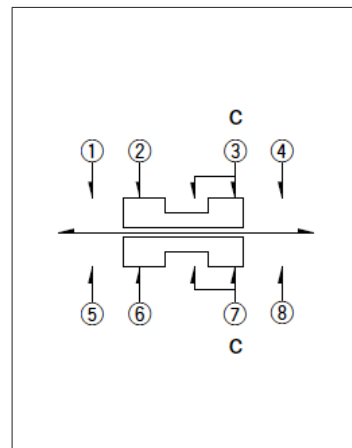

Viewed from direction A in the dimensions.

Drawing No.5

■ Dimensions

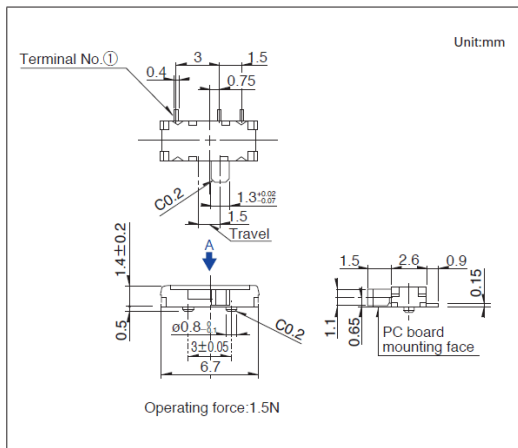

■ Land Dimensions

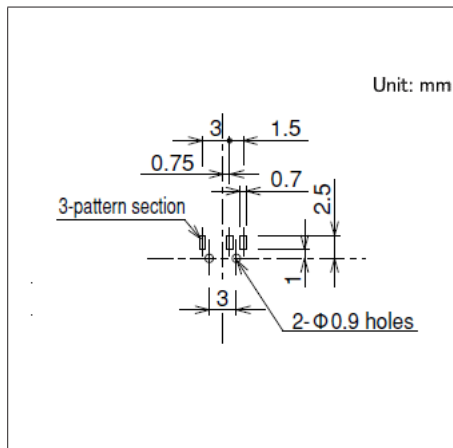

■ Circuit Diagram

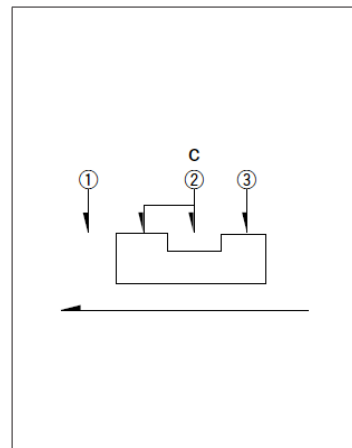

Viewed from direction A in the dimensions.

Drawing No.6

■ Dimensions

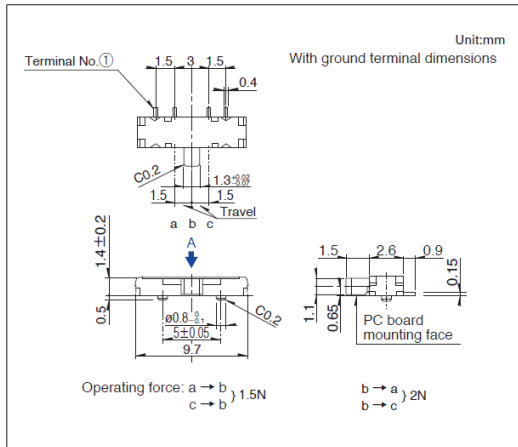

■ Land Dimensions

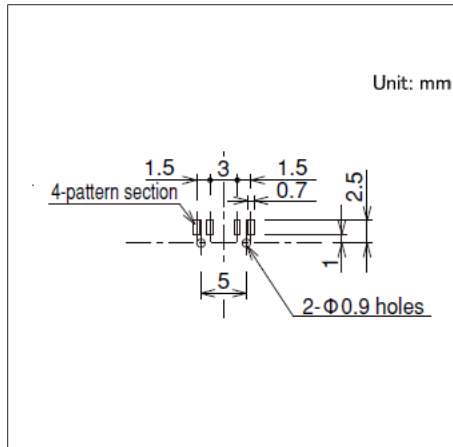

■ Circuit Diagram

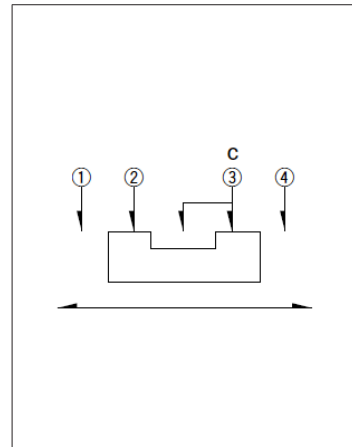

Viewed from direction A in the dimensions.

1.4 (H) mm, 1.5/2.0mm-travel (Surface Mount)
SSSS8 Series

Drawing No.7

■ Dimensions

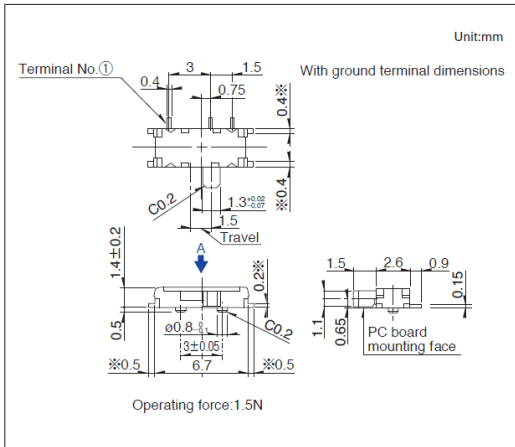

■ Land Dimensions

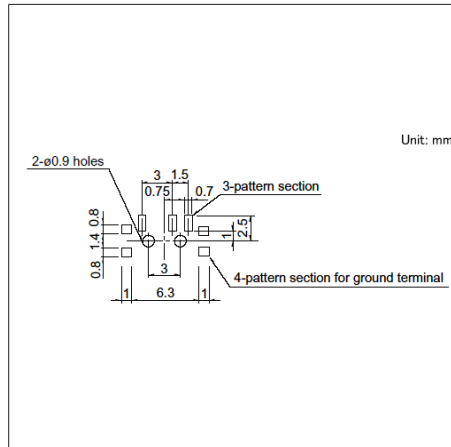

■ Circuit Diagram

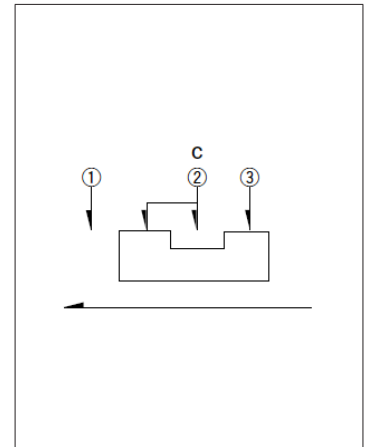

Viewed from direction A in the dimensions.

Drawing No.8

■ Dimensions

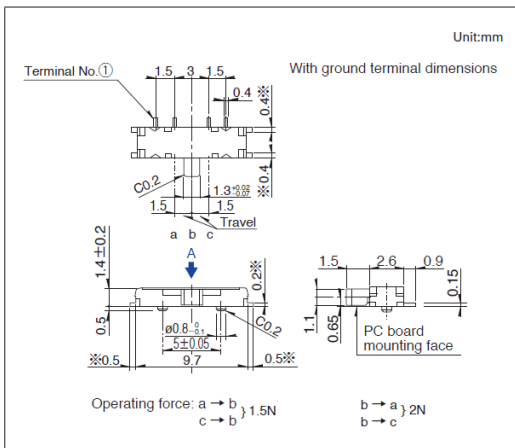

■ Land Dimensions

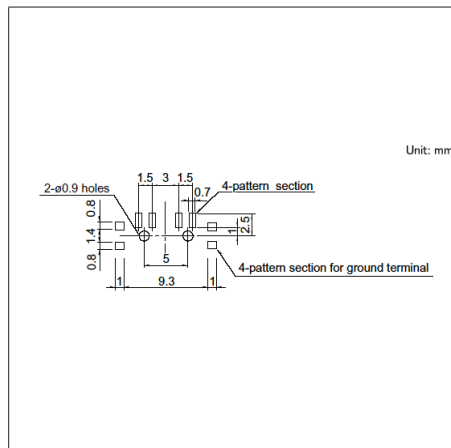

■ Circuit Diagram

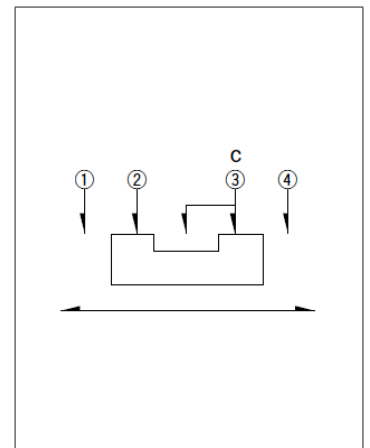

Viewed from direction A in the dimensions.

Drawing No.9

■ Dimensions

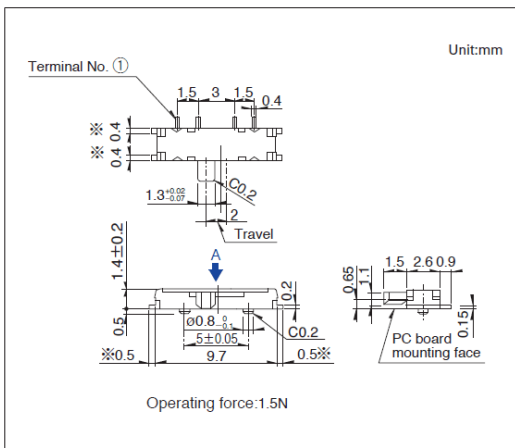

■ Land Dimensions

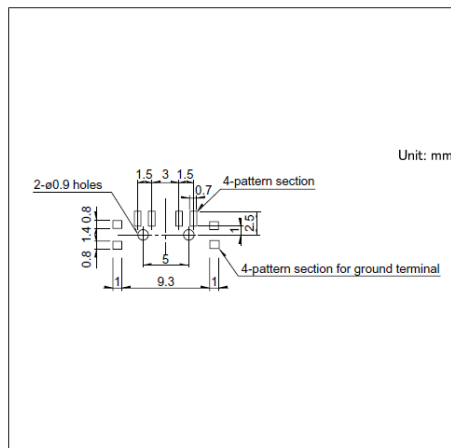

■ Circuit Diagram

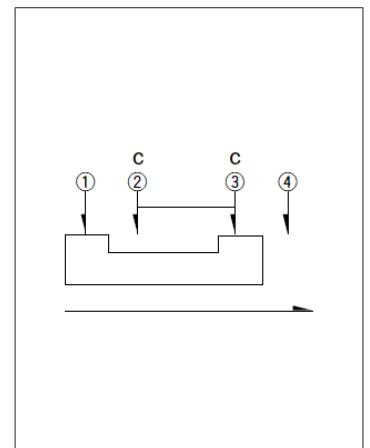

Viewed from direction A in the dimensions.

0.9 (H) mm, Recoil for Single-side and Both-sides

SSAG Series

Long-life type designed to meet the evolution toward miniaturization and thin profiles.

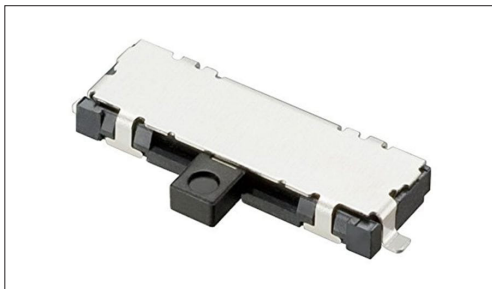

- Rating (max.)/(min.) (Resistive load): 10mA 5V DC/50μA 3V DC
- Contact resistance (Initial performance/After lifetime):
200mΩ max./500mΩ max.
- Operating life without load: 100,000 cycles 500mΩ max. (Recoil side)
30,000 cycles 500mΩ max. (Lock side)
- Operating life with load (at max. rated load):
100,000 cycles 500mΩ max. (Recoil side)
30,000 cycles 500mΩ max. (Lock side)

Applications: Mobile: Smartphones, tablets, Headsets, wearables,
Notebooks, peripherals
Energy_Industrial: Robots, drones, Industrial equipment,
Converters
Game: Home handheld consoles, Virtual/augmented reality
Healthcare: Healthcare equipment, Nursing care equipment,
Analysis, test equipment
Audio_TV: Audio, Cameras

■ Product List

Products No.	Actuator directions	Travel (mm)	Poles	Positions	Operating force	Changeover timing	Soldering	Operation	Shape of frame leg	Location lug	Dimensions (W×D×H) (mm)	Automotive	Drawing No.
SSAG130100	Horizontal	1.5	1	3	1N (Recoil side), 1.5N (Lock side)	Not specified	Reflow	Left-side recoil	For PC board insert	Without	3.0×9.05×1.15	—	1
SSAG130200	Horizontal	1.5	1	3	1N (Recoil side), 1.5N (Lock side)	Not specified	Reflow	Left-side recoil	For PC board insert	With	3.0×9.05×1.15	—	2
SSAG130300	Horizontal	1.5	1	3	1N (Recoil side), 1.5N (Lock side)	Not specified	Reflow	Left-side recoil	Flat	Without	3.0×9.05×1.15	—	3
SSAG130400	Horizontal	1.5	1	3	1N (Recoil side), 1.5N (Lock side)	Not specified	Reflow	Left-side recoil	Flat	With	3.0×9.05×1.15	—	4
SSAG230100	Horizontal	1.5	1	3	1N (Recoil side), 1.5N (Lock side)	Not specified	Reflow	Right-side recoil	For PC board insert	Without	3.0×9.05×1.15	—	5
SSAG230200	Horizontal	1.5	1	3	1N (Recoil side), 1.5N (Lock side)	Not specified	Reflow	Right-side recoil	For PC board insert	With	3.0×9.05×1.15	—	6
SSAG230300	Horizontal	1.5	1	3	1N (Recoil side), 1.5N (Lock side)	Not specified	Reflow	Right-side recoil	Flat	Without	3.0×9.05×1.15	—	7
SSAG230400	Horizontal	1.5	1	3	1N (Recoil side), 1.5N (Lock side)	Not specified	Reflow	Right-side recoil	Flat	With	3.0×9.05×1.15	—	8
SSAG330100	Horizontal	1.5	1	3	1N (Recoil side)	Not specified	Reflow	Double-side recoil	For PC board insert	Without	3.0×9.05×1.15	—	9
SSAG330200	Horizontal	1.5	1	3	1N (Recoil side)	Not specified	Reflow	Double-side recoil	For PC board insert	With	3.0×9.05×1.15	—	10
SSAG330300	Horizontal	1.5	1	3	1N (Recoil side)	Not specified	Reflow	Double-side recoil	Flat	Without	3.0×9.05×1.15	—	11
SSAG330400	Horizontal	1.5	1	3	1N (Recoil side)	Not specified	Reflow	Double-side recoil	Flat	With	3.0×9.05×1.15	—	12

⚠ Note

1. This catalog shows only outline specifications. When using the products, please obtain formal specifications for supply.
2. Please place purchase orders for taping products per minimum order unit (1 reel or a case).

Switches

Slide Switches

0.9 (H) mm, Recoil for Single-side and Both-sides
SSAG Series

■ Packing Specifications

Taping

Number of packages (pcs.)			Tape width (mm)	Export package measurements (mm)
1 reel	1 case / Japan	1 case / export packing		
4,000	8,000	16,000	24	428 x 413 x 172

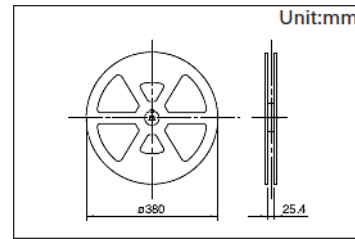

Drawing No.1

■ Dimensions

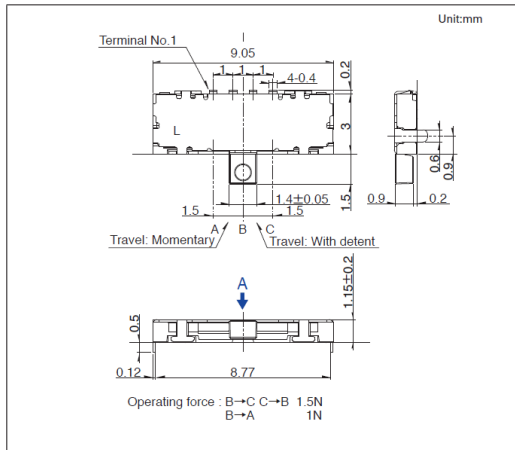

■ Land Dimensions

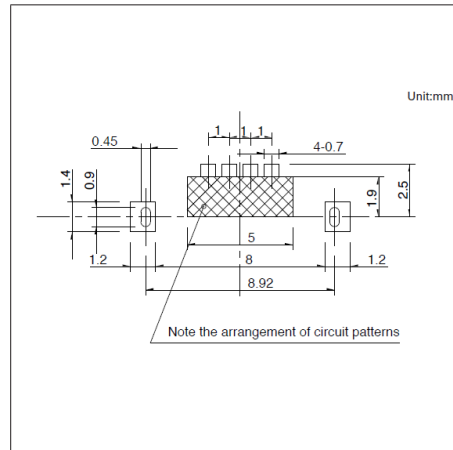

■ Circuit Diagram

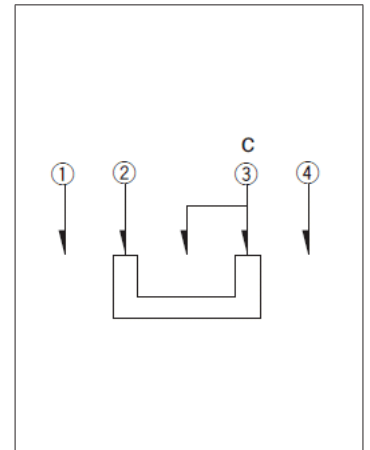

Viewed from direction A in the dimensions.

Drawing No.2

■ Dimensions

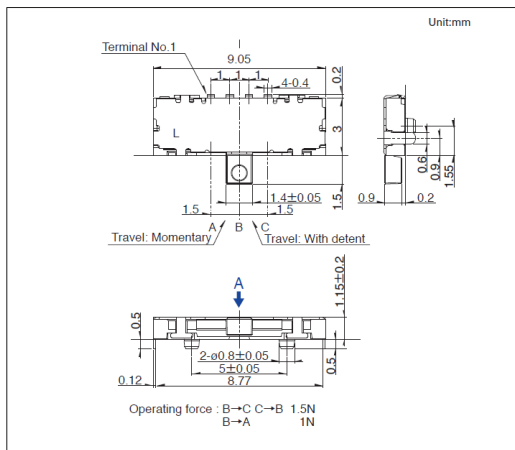

■ Land Dimensions

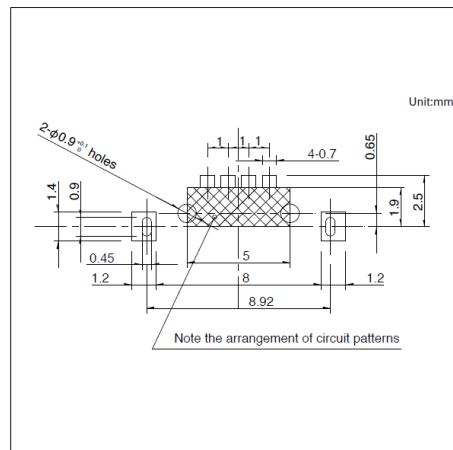

■ Circuit Diagram

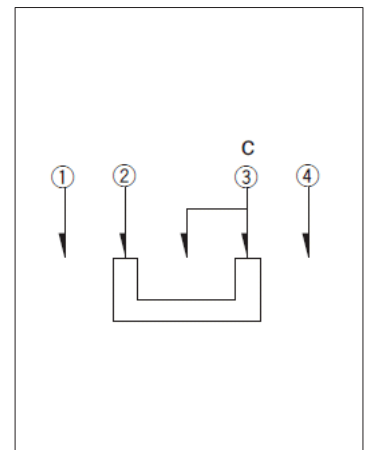

Viewed from direction A in the dimensions.

Switches Slide Switches

0.9 (H) mm, Recoil for Single-side and Both-sides
SSAG Series

Drawing No.3

■ Dimensions

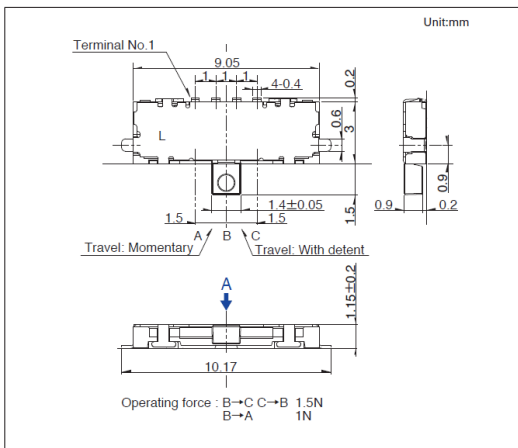

■ Land Dimensions

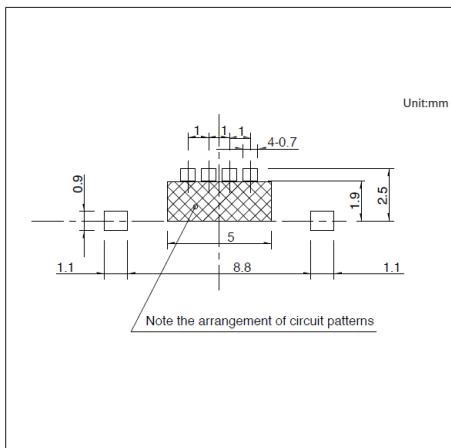

■ Circuit Diagram

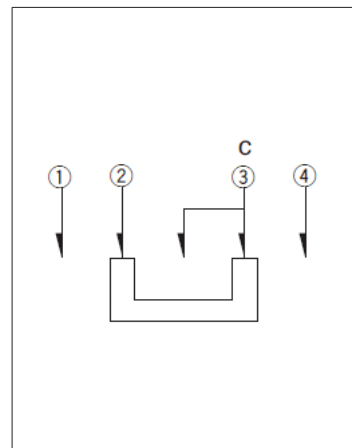

Viewed from direction A in the dimensions.

Drawing No.4

■ Dimensions

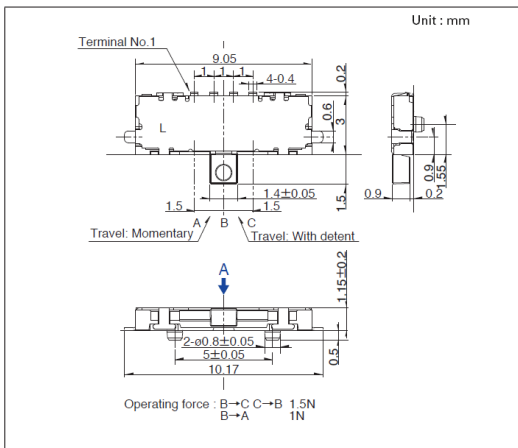

■ Land Dimensions

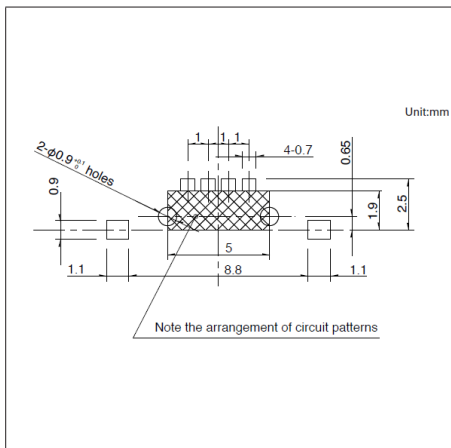

■ Circuit Diagram

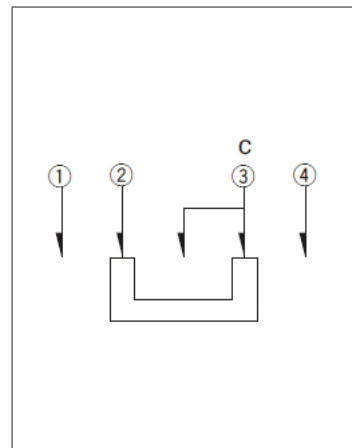

Viewed from direction A in the dimensions.

Drawing No.5

■ Dimensions

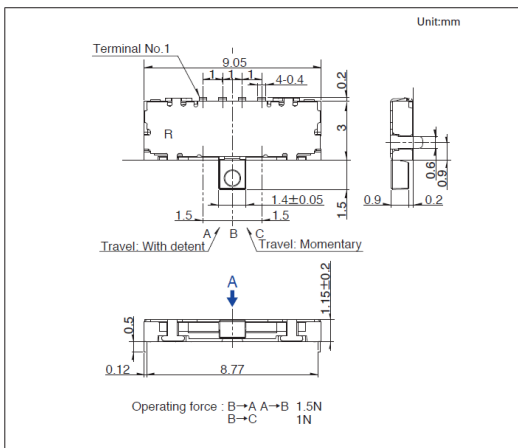

■ Land Dimensions

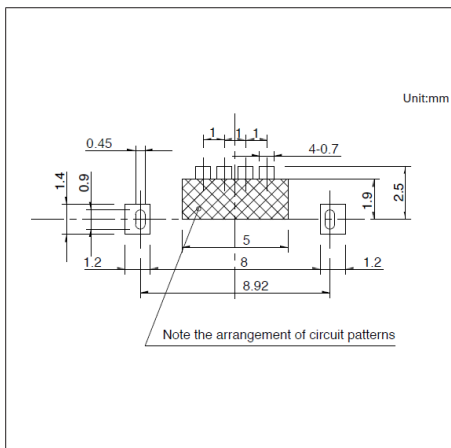

■ Circuit Diagram

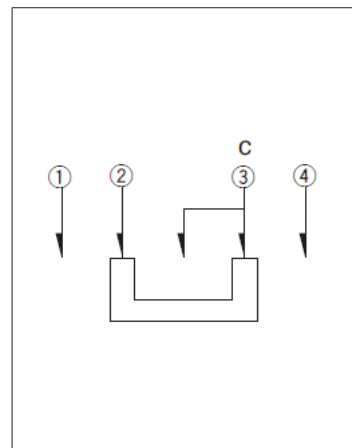

Viewed from direction A in the dimensions.

0.9 (H) mm, Recoil for Single-side and Both-sides
SSAG Series

Drawing No.6

■ Dimensions

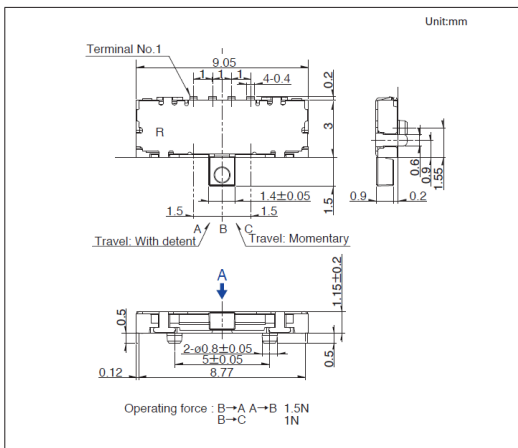

■ Land Dimensions

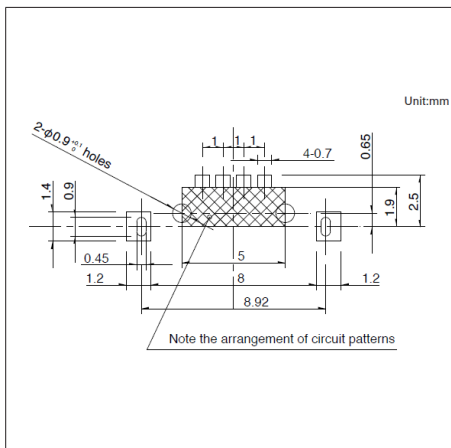

■ Circuit Diagram

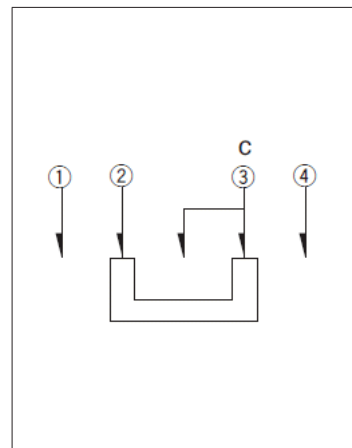

Viewed from direction A in the dimensions.

Drawing No.7

■ Dimensions

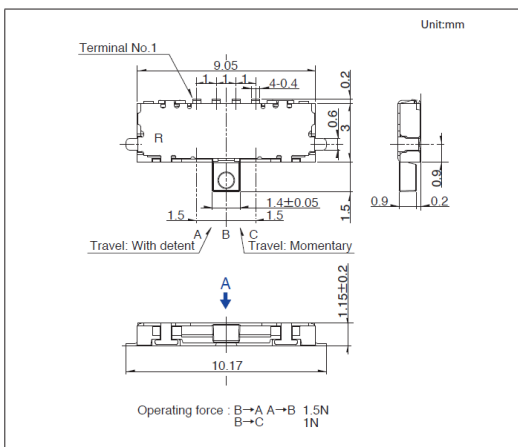

■ Land Dimensions

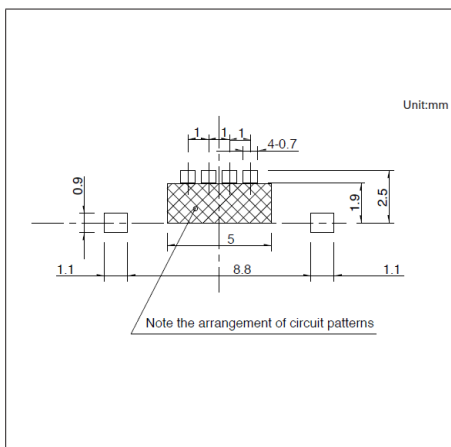

■ Circuit Diagram

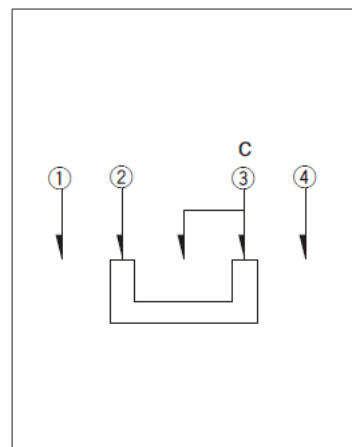

Viewed from direction A in the dimensions.

Drawing No.8

■ Dimensions

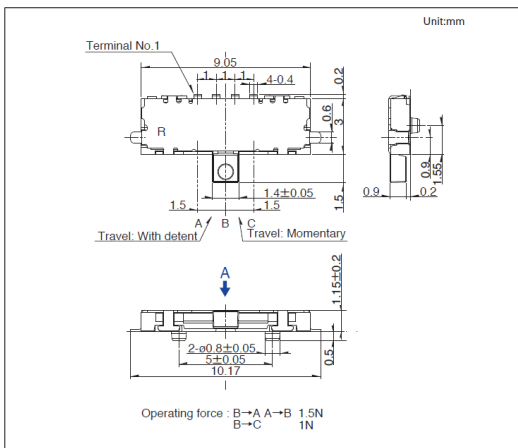

■ Land Dimensions

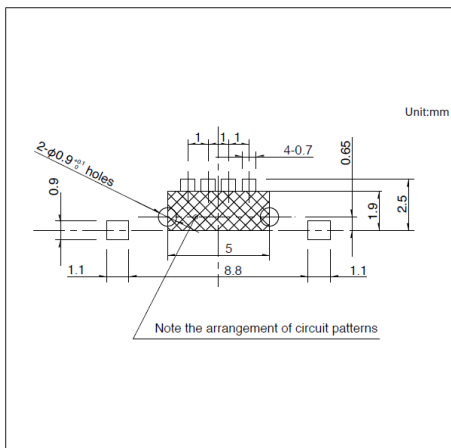

■ Circuit Diagram

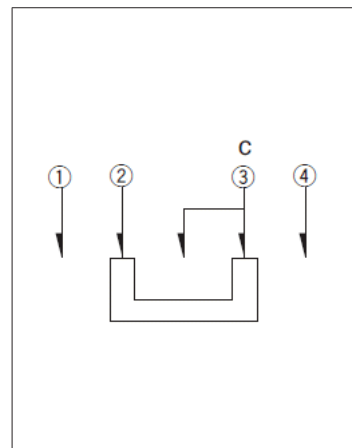

Viewed from direction A in the dimensions.

Drawing No.9

■ Dimensions

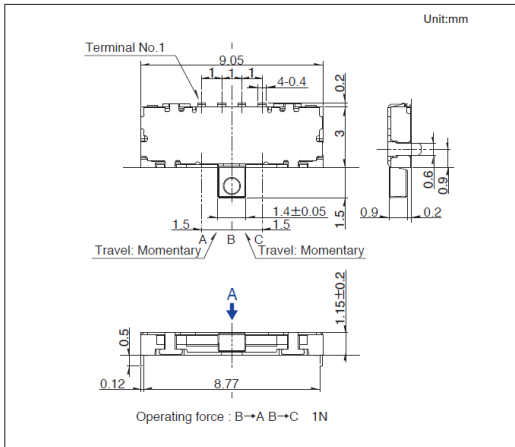

■ Land Dimensions

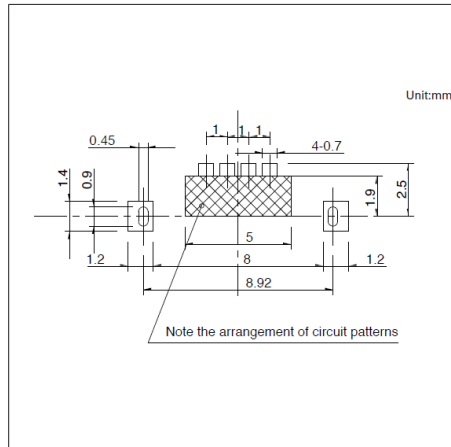

■ Circuit Diagram

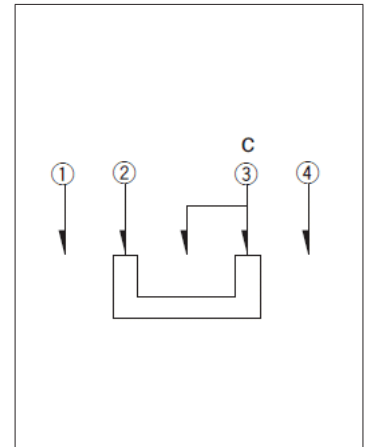

Viewed from direction A in the dimensions.

Drawing No.10

■ Dimensions

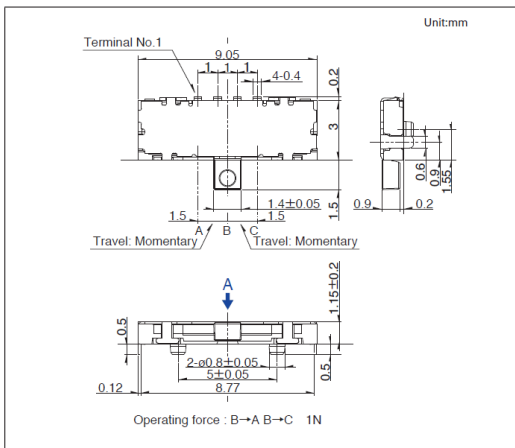

■ Land Dimensions

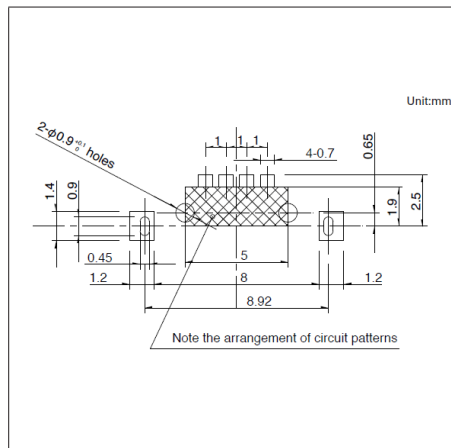

■ Circuit Diagram

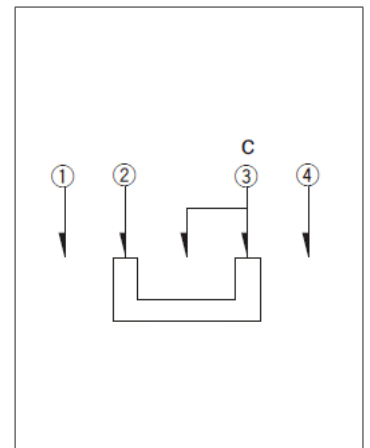

Viewed from direction A in the dimensions.

Drawing No.11

■ Dimensions

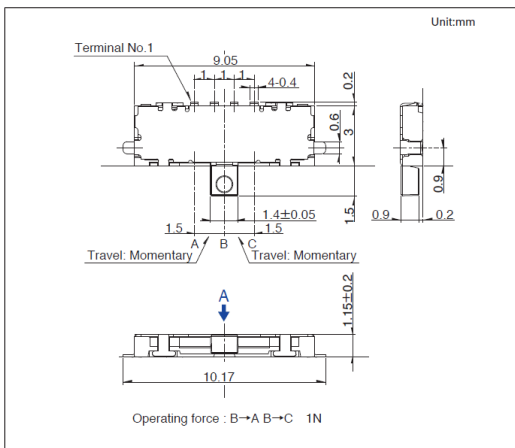

■ Land Dimensions

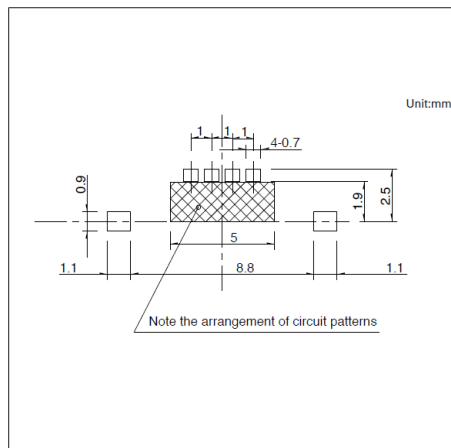

■ Circuit Diagram

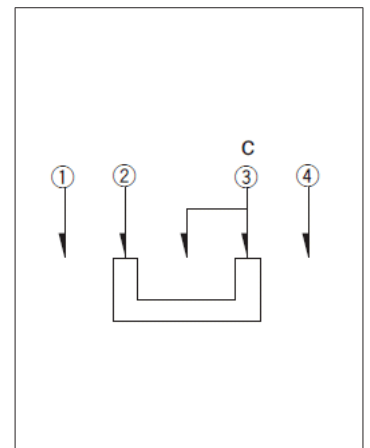

Viewed from direction A in the dimensions.

Drawing No.12

■ Dimensions

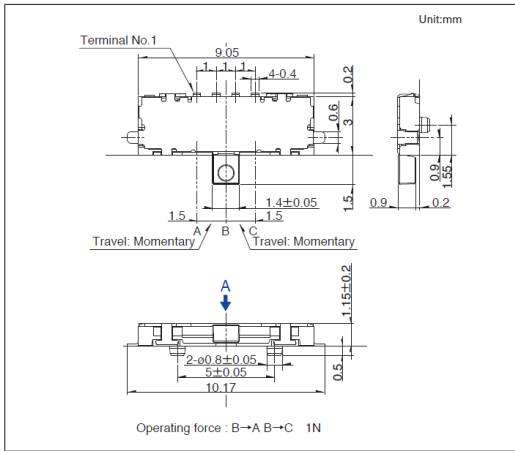

■ Land Dimensions

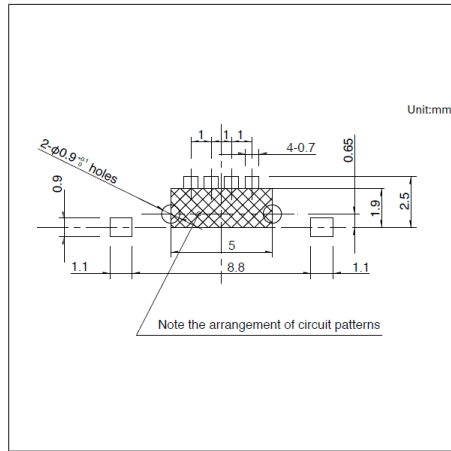

■ Circuit Diagram

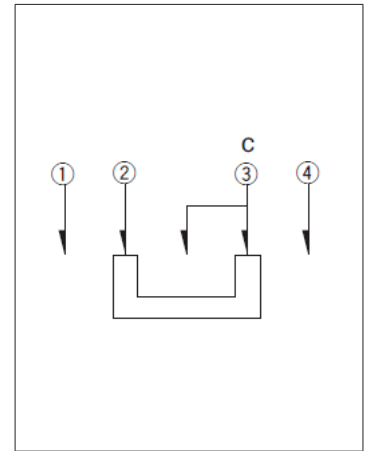

Viewed from direction A in the dimensions.

Switches

Slide Switches

2.0 (H) mm, 2.0mm-travel
SSSS7 Series

Compact general-purpose type with selectable soldering methods.

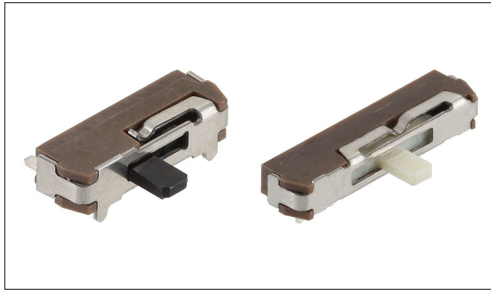

- Rating (max.)/(min.) (Resistive load): 0.3A 4V DC/50μA 3V DC
- Contact resistance (Initial performance/After lifetime):
70mΩ max./130mΩ max.
- Operating life without load: 10,000 cycles 100mΩ max.
- Operating life with load (at max. rated load): 10,000 cycles 130mΩ max.

Applications: Mobile: Notebooks, peripherals
Audio_TV: Cameras

■ Product List

Products No.	Actuator directions	Travel (mm)	Poles	Positions	Operating force	Changeover timing	Soldering	Operation	Dimensions (W×D×H) (mm)	Automotive	Drawing No.
SSSS710100	Horizontal	2.0	1	2	Refer to the dimensions.	Not specified	Manual	Standard	8.8×3.0×2.0	—	1
SSSS710607	Horizontal	2.0	1	2	Refer to the dimensions.	Not specified	Reflow	Standard	8.8×3.0×2.0	—	2
SSSS711100	Horizontal	2.0	1	3	Refer to the dimensions.	Non shorting	Manual	Standard	12.5×3.0×2.0	—	3
SSSS711403	Horizontal	2.0	1	3	Refer to the dimensions.	Non shorting	Reflow	Standard	12.5×3.0×2.0	—	4

⚠ Note

1. This catalog shows only outline specifications. When using the products, please obtain formal specifications for supply.
2. Please place purchase orders per minimum order unit (integer).
3. Please place purchase orders for taping products per minimum order unit (1 reel or a case).

■ Packing Specifications

Bulk

Products No.	Number of packages(pcs.)		Export package measurements (mm)
	1 case / Japan	1 case / export packing	
SSSS710100	10,000	50,000	400 x 270 x 290
SSSS711100	8,000	40,000	400 x 270 x 290

Taping

Products No.	Number of packages(pcs.)			Tape width (mm)	Export package measurements (mm)
	1 reel	1 case / Japan	1 case / export packing		
SSSS710607	2,000	4,000	8,000	16	417 x 409 x 139
SSSS711403	2,000	4,000	8,000	24	406 x 406 x 190

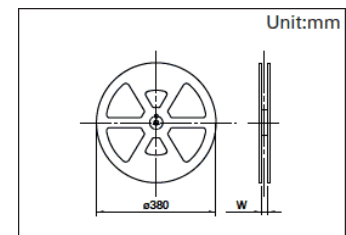

Switches Slide Switches

2.0 (H) mm, 2.0mm-travel
SSSS7 Series

Drawing No.1

■ Dimensions

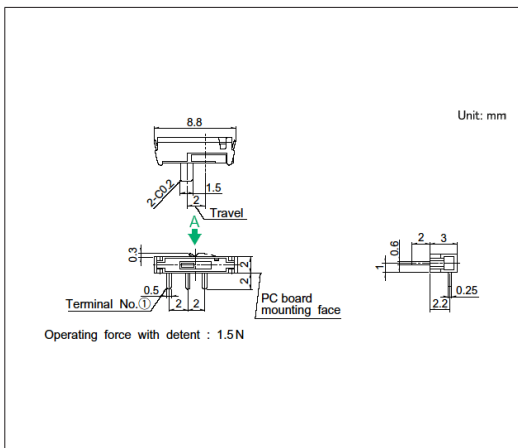

■ Mounting Hole Dimensions

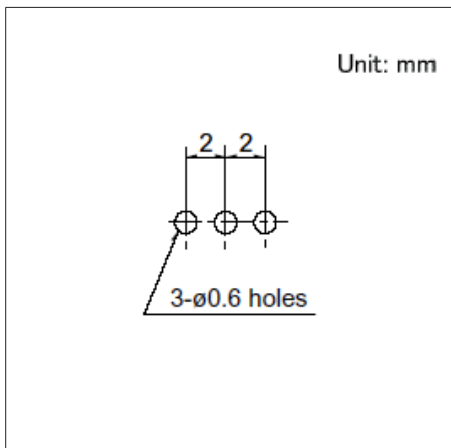

■ Circuit Diagram

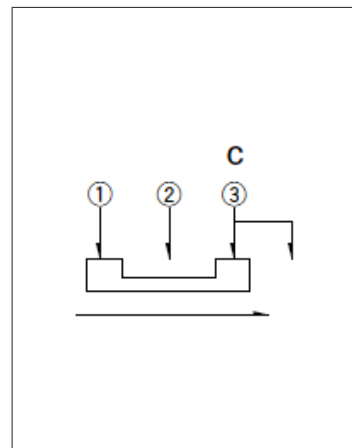

Viewed from direction A in the dimensions.

Drawing No.2

■ Dimensions

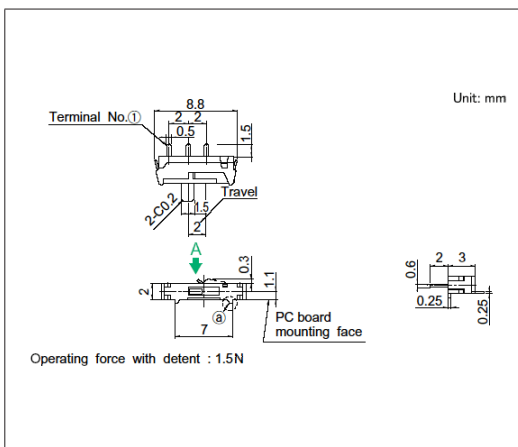

■ Land Dimensions

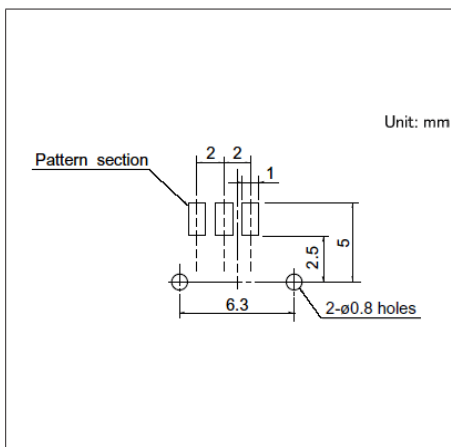

■ Circuit Diagram

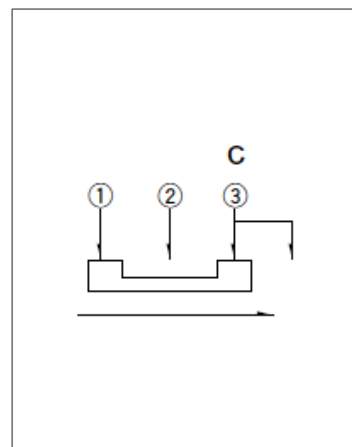

Refer to the website for detail of ②

Viewed from direction A in the dimensions.

Drawing No.3

■ Dimensions

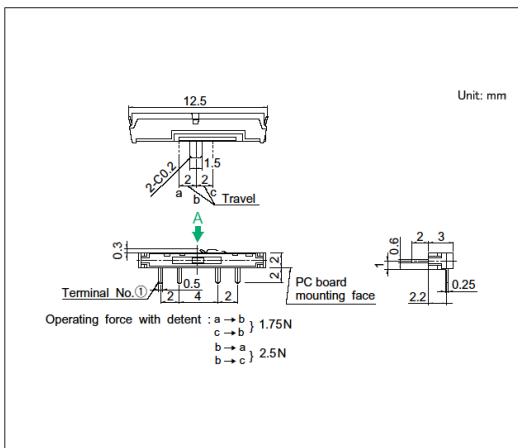

■ Mounting Hole Dimensions

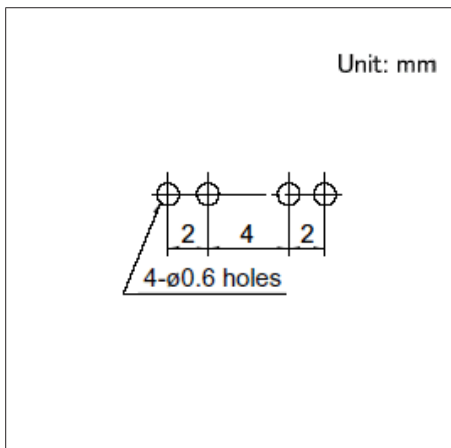

■ Circuit Diagram

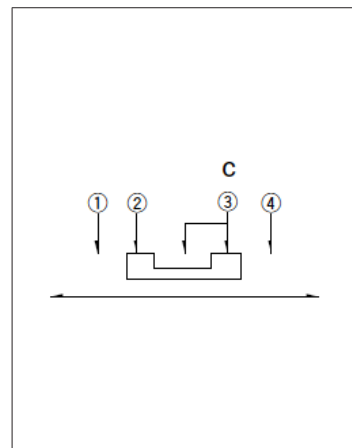

Viewed from direction A in the dimensions.

Drawing No.4

■ Dimensions

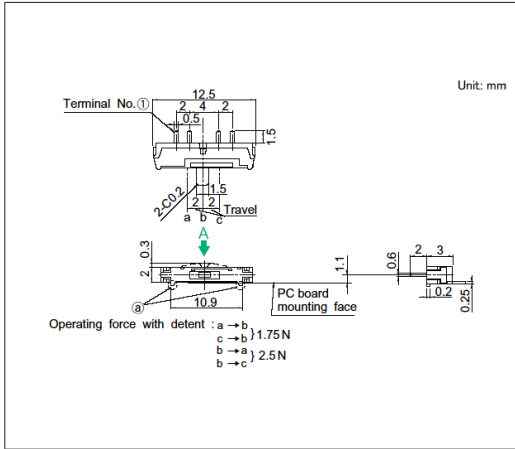

Refer to the website for detail of ©

■ Land Dimensions

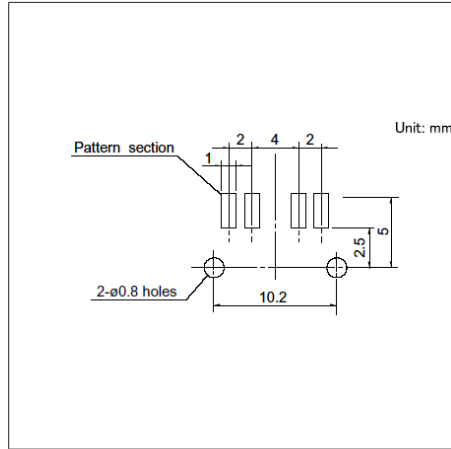

Viewed from direction A in the dimensions.

■ Circuit Diagram

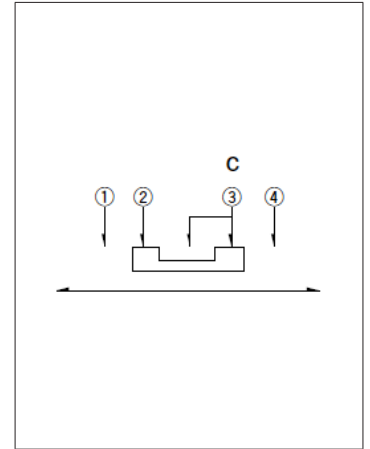

Switches

Slide Switches

3.5 (H) mm, 2.0mm-travel
SSSS2 Series

Supports miniaturization and high-density integration for various mobile devices.

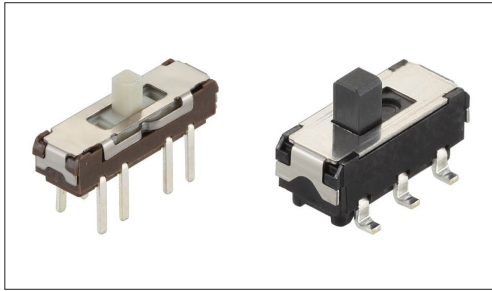

- Rating (max.)/(min.) (Resistive load): 0.3A 6V DC/50 μ A 3V DC
 - Contact resistance (Initial performance/After lifetime):
70m Ω max./130m Ω max.
 - Operating life without load: 10,000 cycles 100m Ω max. ※
 - Operating life with load (at max. rated load): 10,000 cycles 130m Ω max. ※
- ⚠ **Note** ※SSSS213202 only 100 cycles

Applications: Healthcare: Healthcare equipment
Home: Major home appliances
Audio_TV: Audio

■ Product List

Products No.	Actuator directions	Travel (mm)	Poles	Positions	Operating force	Changeover timing	Soldering	Dimensions (W×D×H) (mm)	Automotive	Drawing No.
SSSS213000	Vertical	2.0	1	2	Refer to the dimensions.	Non shorting	Manual, Dip	9.0×3.5×3.5	—	1
SSSS211900	Vertical	2.0	1	3	Refer to the dimensions.	Non shorting	Manual, Dip	13.0×3.5×3.5	—	2
SSSS222700	Vertical	2.0	2	2	Refer to the dimensions.	Non shorting	Manual, Dip	9.0×3.5×3.5	—	3
SSSS223600	Vertical	2.0	2	3	Refer to the dimensions.	Non shorting	Manual, Dip	13.0×3.5×3.5	—	4
SSSS213202	Vertical	2.0	1	2	Refer to the dimensions.	Non shorting	Reflow	8.5×3.5×3.5	—	5
SSSS212901	Vertical	2.0	1	3	Refer to the dimensions.	Non shorting	Reflow	13.0×3.5×3.5	—	6
SSSS213100	Horizontal	2.0	1	2	Refer to the dimensions.	Non shorting	Manual, Dip	9.0×3.5×3.5	—	7
SSSS212200	Horizontal	2.0	1	3	Refer to the dimensions.	Non shorting	Manual, Dip	13.0×3.5×3.5	—	8
SSSS212400	Horizontal	2.0	1	4	Refer to the dimensions.	Non shorting	Manual, Dip	15.0×3.5×3.5	—	9
SSSS223200	Horizontal	2.0	2	2	Refer to the dimensions.	Non shorting	Manual, Dip	9.0×3.5×3.5	—	10
SSSS223900	Horizontal	2.0	2	3	Refer to the dimensions.	Non shorting	Manual, Dip	13.0×3.5×3.5	—	11
SSSS224100	Horizontal	2.0	2	4	Refer to the dimensions.	Non shorting	Manual, Dip	15.0×3.5×3.5	—	12
SSSS211603	Horizontal	2.0	1	2	Refer to the dimensions.	Non shorting	Reflow	9.0×3.5×3.5	—	13
SSSS213800	Horizontal	2.0	1	3	Refer to the dimensions.	Non shorting	Reflow	13.0×3.5×3.5	—	14
SSSS224500	Horizontal	2.0	2	3	Refer to the dimensions.	Non shorting	Reflow	13.0×3.5×3.5	—	15

⚠ **Note**

1. This catalog shows only outline specifications. When using the products, please obtain formal specifications for supply.
2. Please place purchase orders per minimum order unit (integer).
3. Please place purchase orders for taping products per minimum order unit (1 reel or a case).

■ Packing Specifications

Bulk

Products No.	Number of packages(pcs.)		Export package measurements (mm)
	1 case / Japan	1 case / export packing	
SSSS213000 SSSS211900 SSSS222700 SSSS223600 SSSS213100 SSSS212200 SSSS212400 SSSS223200 SSSS223900 SSSS224100	2,000	10,000	400 x 270 x 290

3.5 (H) mm, 2.0mm-travel
SSSS2 Series

Taping

Products No.	Number of packages(pcs.)			Tape width (mm)	Export package measurements (mm)
	1 reel	1 case / Japan	1 case / export packing		
SSSS213202	1,200	2,400	4,800	24	428 x 413 x 172
SSSS212901	1,000	2,000	4,000	24	406 x 406 x 190
SSSS211603 SSSS213800 SSSS224500	1,400	2,800	5,600	24	406 x 406 x 190

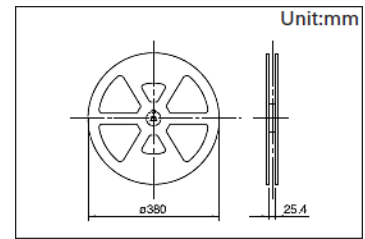

Drawing No.1

■ Dimensions

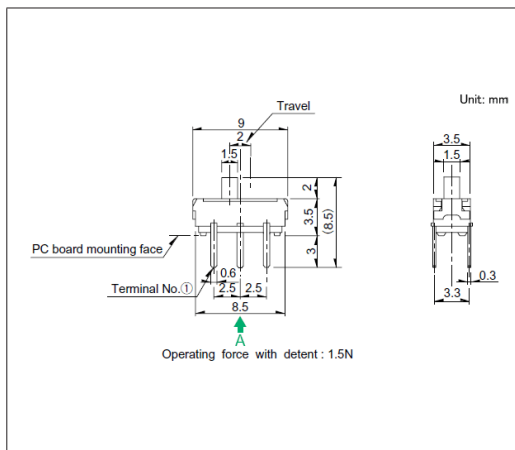

■ Mounting Hole Dimensions

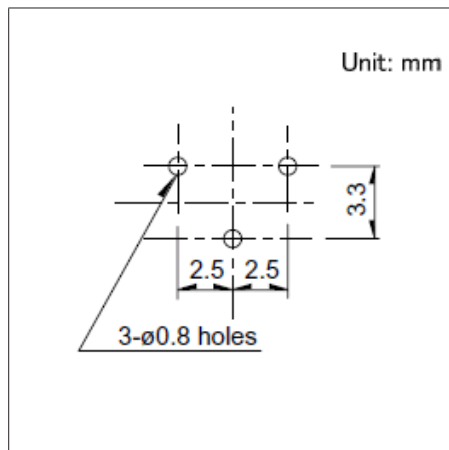

■ Circuit Diagram

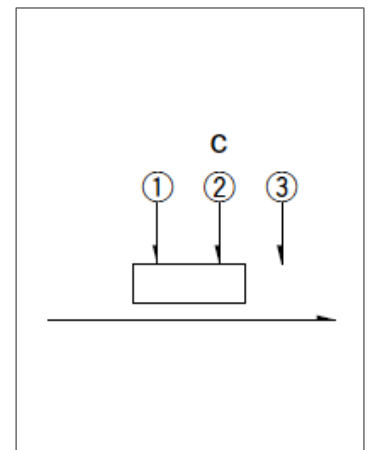

Viewed from direction A in the dimensions.

Drawing No.2

■ Dimensions

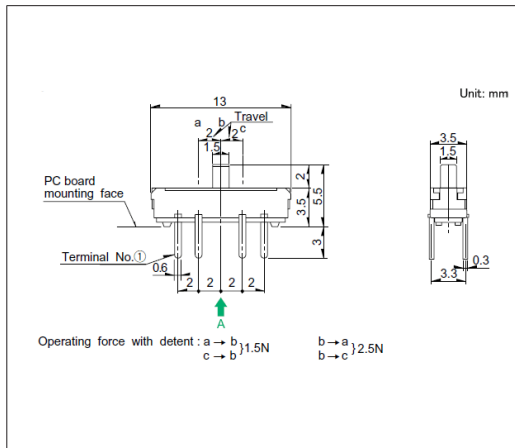

■ Mounting Hole Dimensions

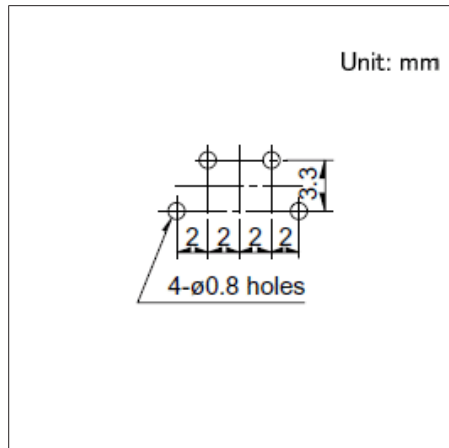

■ Circuit Diagram

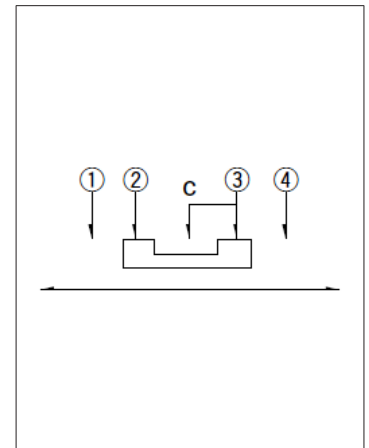

Viewed from direction A in the dimensions.

Switches Slide Switches

3.5 (H) mm, 2.0mm-travel
SSSS2 Series

Drawing No.3

■ Dimensions

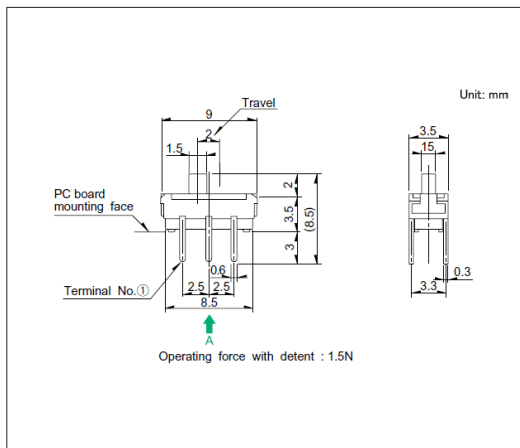

■ Mounting Hole Dimensions

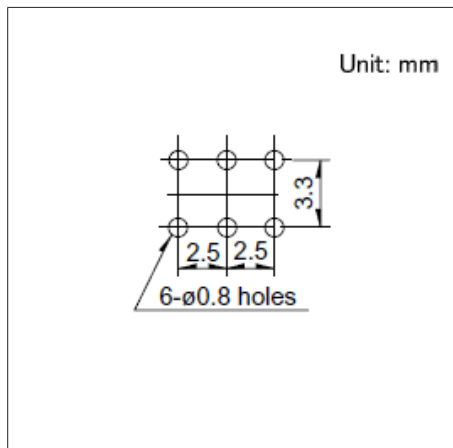

■ Circuit Diagram

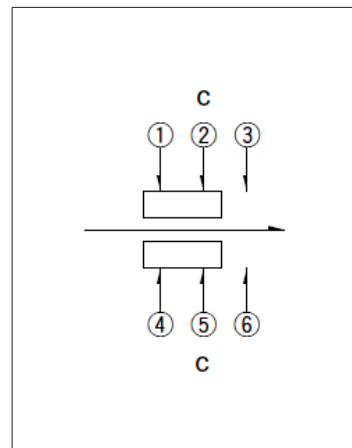

Viewed from direction A in the dimensions.

Drawing No.4

■ Dimensions

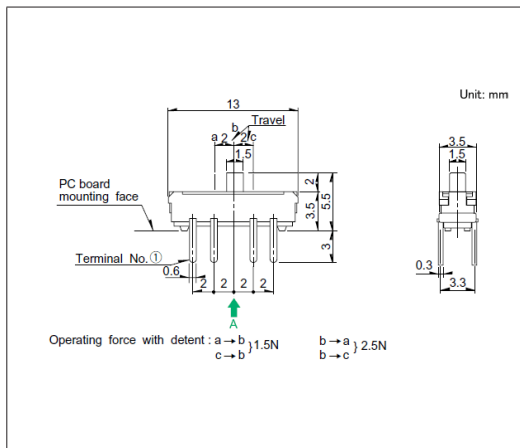

■ Mounting Hole Dimensions

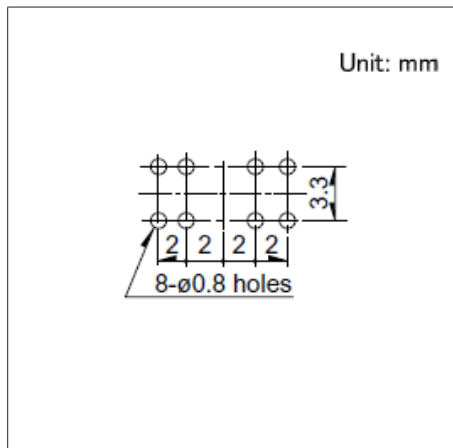

■ Circuit Diagram

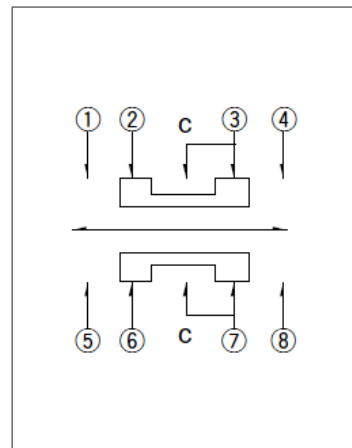

Viewed from direction A in the dimensions.

Drawing No.5

■ Dimensions

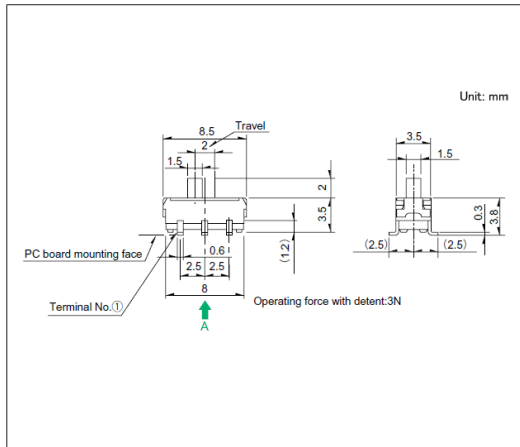

■ Land Dimensions

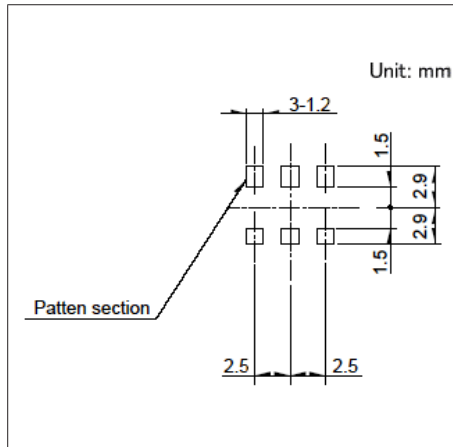

■ Circuit Diagram

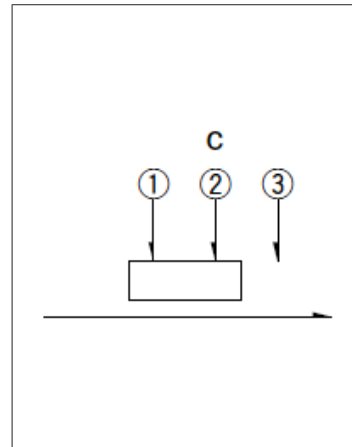

Viewed from direction A in the dimensions.

Switches Slide Switches

3.5 (H) mm, 2.0mm-travel
SSSS2 Series

Drawing No.6

■ Dimensions

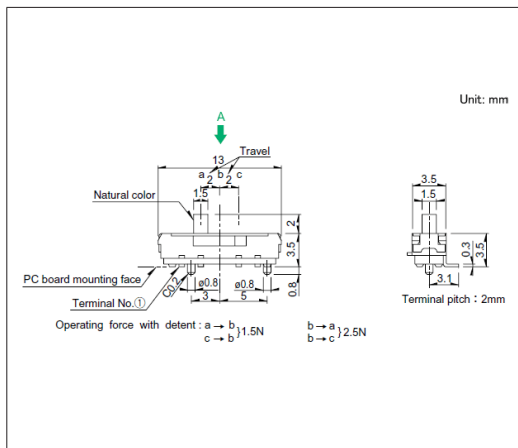

■ Land Dimensions

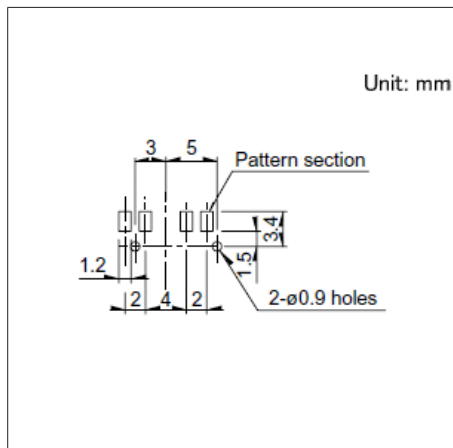

■ Circuit Diagram

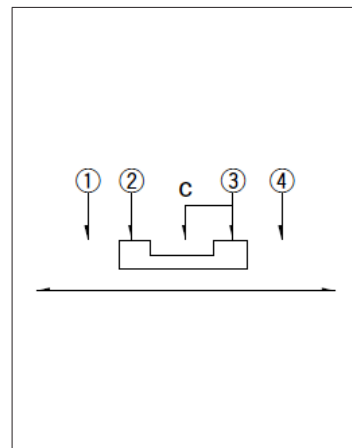

Viewed from direction A in the dimensions.

Drawing No.7

■ Dimensions

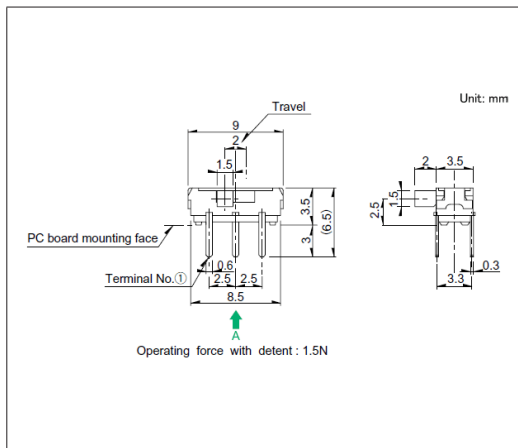

■ Mounting Hole Dimensions

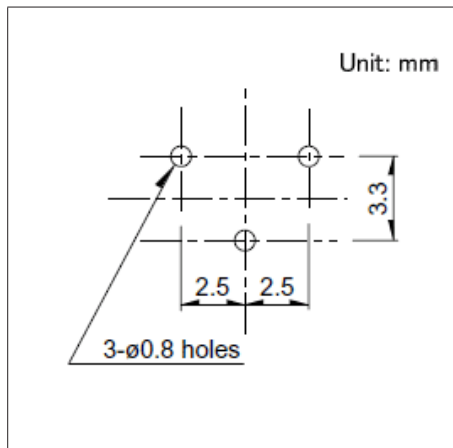

■ Circuit Diagram

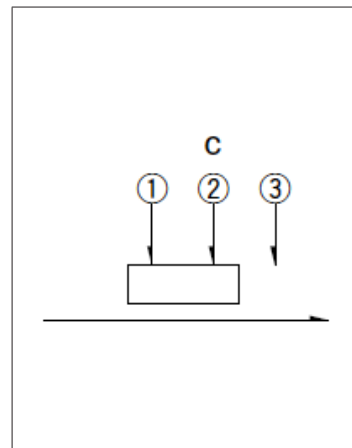

Viewed from direction A in the dimensions.

Drawing No.8

■ Dimensions

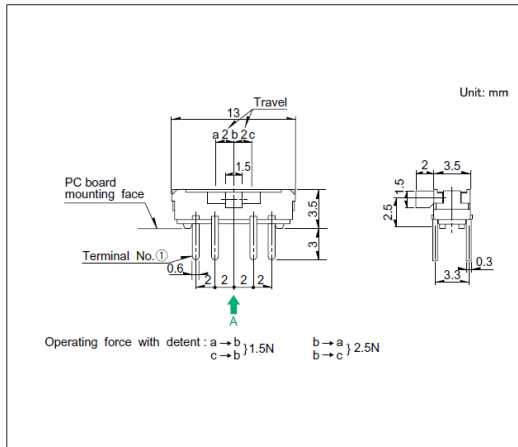

■ Mounting Hole Dimensions

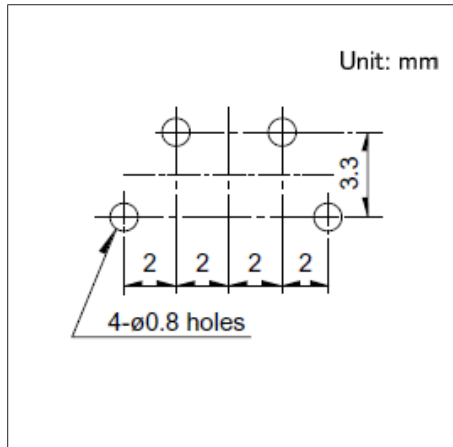

■ Circuit Diagram

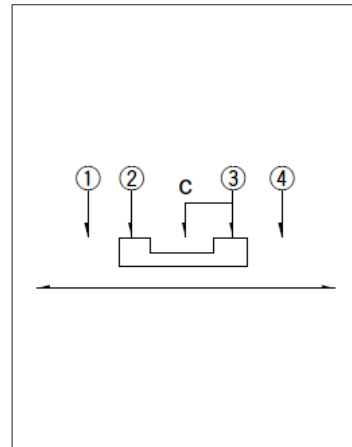

Viewed from direction A in the dimensions.

3.5 (H) mm, 2.0mm-travel
SSSS2 Series

Drawing No.9

■ Dimensions

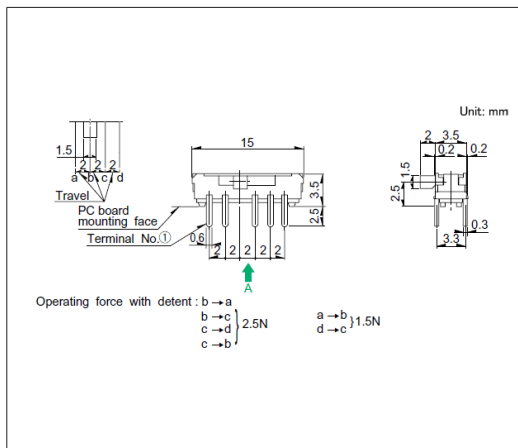

■ Mounting Hole Dimensions

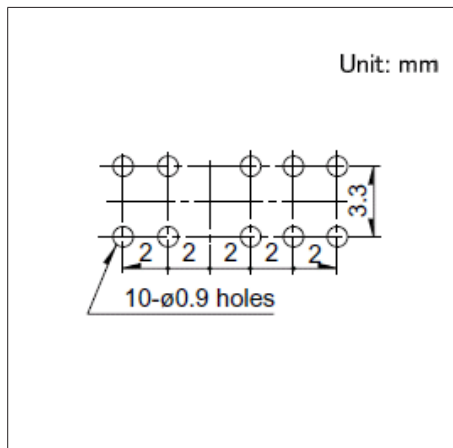

■ Circuit Diagram

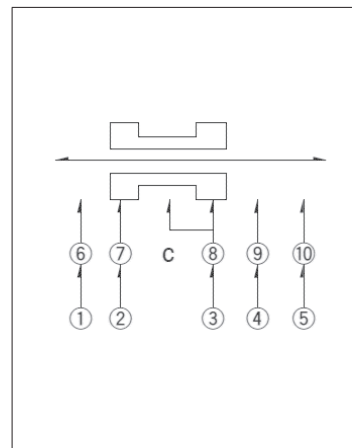

Viewed from direction A in the dimensions.

Drawing No.10

■ Dimensions

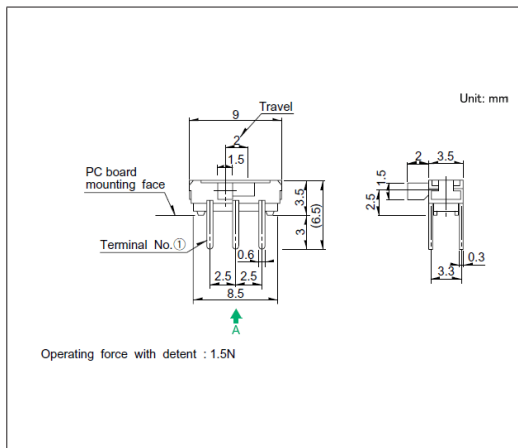

■ Mounting Hole Dimensions

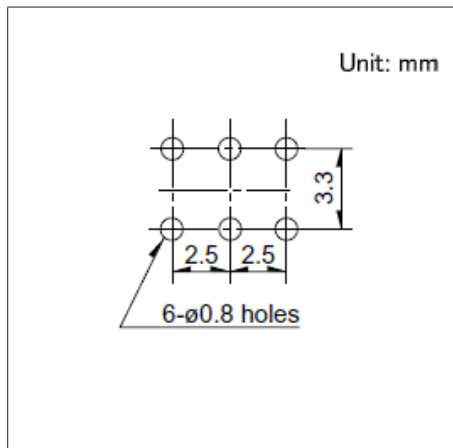

■ Circuit Diagram

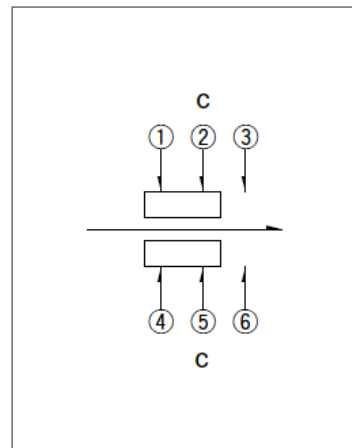

Viewed from direction A in the dimensions.

Drawing No.11

■ Dimensions

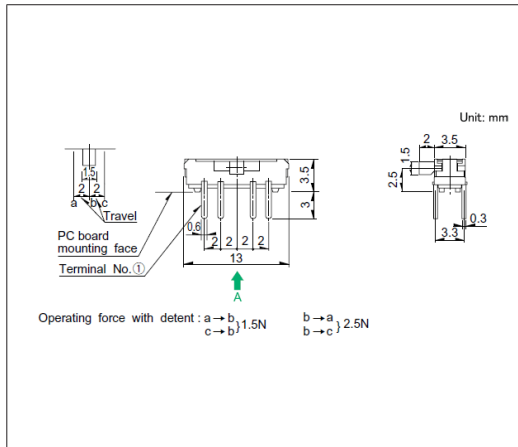

■ Mounting Hole Dimensions

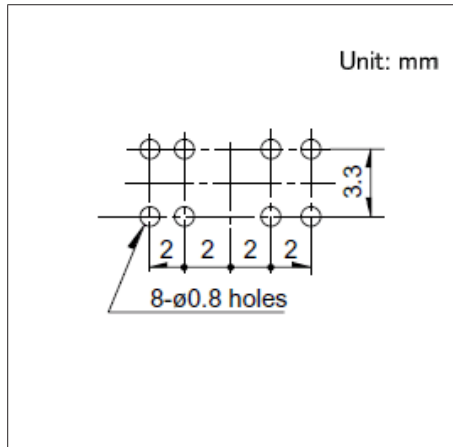

■ Circuit Diagram

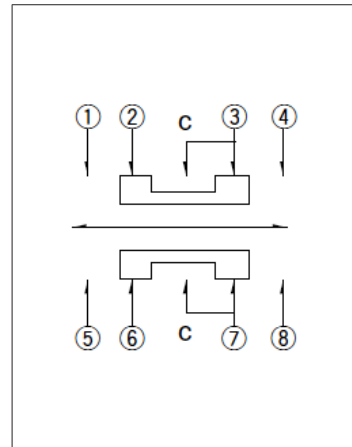

Viewed from direction A in the dimensions.

Switches

Slide Switches

5.0 (H) mm, 2.0mm-travel

SSSS9 Series

Medium-sized general-purpose type well known for ease of use.

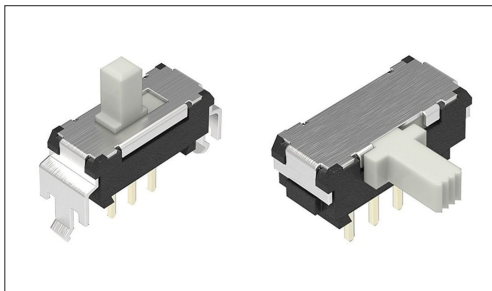

- Rating (max.)/(min.) (Resistive load): 0.1 A 12V DC/1mA 5V DC
- Contact resistance (Initial performance/After lifetime):
30mΩ max./80mΩ max.
- Operating life without load: 10,000 cycles 60mΩ max.
- Operating life with load (at max. rated load): 10,000 cycles 80mΩ max.

Applications: Home: Major home appliances

■ Product List

Products No.	Actuator directions	Travel (mm)	Poles	Positions	Operating force	Changeover timing	Soldering	Dimensions (W×D×H) (mm)	Automotive	Drawing No.
SSSS912000	Vertical	2.0	1	2	3±1.5N	Non shorting	Manual, Dip	11.5×4.7×5.5	—	1
SSSS910400	Vertical	2.0	1	2	3±1.5N	Non shorting	Manual, Dip	11.5×4.7×5.5	—	2
SSSS919500	Vertical	2.0	1	3	a, c → b 2±1N b → a, c 3±1.5N	Not specified	Manual, Dip	14.0×4.7×5.5	—	3
SSSS918500	Vertical	2.0	1	3	a, c → b 2±1N b → a, c 3±1.5N	Not specified	Manual, Dip	14.0×4.7×5.5	—	4
SSSS922000	Vertical	2.0	2	2	3±1.5N	Non shorting	Manual, Dip	11.5×7.2×5.5	—	5
SSSS921800	Vertical	2.0	2	3	a, c → b 2±1N b → a, c 3±1.5N	Not specified	Manual, Dip	14.0×7.2×5.5	—	6
SSSS912500	Vertical	2.0	1	2	3±1.5N	Non shorting	Manual, Dip	11.5×4.7×5.5	—	7
SSSS910800	Vertical	2.0	1	2	3±1.5N	Non shorting	Manual, Dip	11.5×4.7×5.5	—	8
SSSS919800	Vertical	2.0	1	3	a, c → b 2±1N b → a, c 3±1.5N	Not specified	Manual, Dip	14.0×4.7×5.5	—	9
SSSS918700	Vertical	2.0	1	3	a, c → b 2±1N b → a, c 3±1.5N	Not specified	Manual, Dip	14.0×4.7×5.5	—	10
SSSS922500	Vertical	2.0	2	2	3±1.5N	Non shorting	Manual, Dip	11.5×7.2×5.5	—	11
SSSS923200	Vertical	2.0	2	3	a, c → b 2±1N b → a, c 3±1.5N	Not specified	Manual, Dip	14.0×7.2×5.5	—	12
SSSS920600	Vertical	2.0	2	3	a, c → b 2±1N b → a, c 3±1.5N	Not specified	Manual, Dip	14.0×7.2×5.5	—	13
SSSS916900	Horizontal	2.0	1	2	3±1.5N	Non shorting	Manual, Dip	11.5×4.7×5.0	—	14
SSSS915001	Horizontal	2.0	1	2	3±1.5N	Non shorting	Manual, Dip	11.5×4.7×5.0	—	15
SSSS91B900	Horizontal	2.0	1	3	a, c → b 2±1N b → a, c 3±1.5N	Not specified	Manual, Dip	14.0×4.7×5.0	—	16
SSSS926400	Horizontal	2.0	2	2	3±1.5N	Non shorting	Manual, Dip	11.5×7.2×5.0	—	17
SSSS928500	Horizontal	2.0	2	3	a, c → b 2±1N b → a, c 3±1.5N	Not specified	Manual, Dip	14.0×7.2×5.0	—	18
SSSS916400	Horizontal	2.0	1	2	3±1.5N	Non shorting	Manual, Dip	11.5×4.7×5.0	—	19
SSSS914503	Horizontal	2.0	1	2	3±1.5N	Non shorting	Manual, Dip	11.5×4.7×5.0	—	20
SSSS91B600	Horizontal	2.0	1	3	a, c → b 2±1N b → a, c 3±1.5N	Not specified	Manual, Dip	14.0×4.7×5.0	—	21
SSSS91A601	Horizontal	2.0	1	3	a, c → b 2±1N b → a, c 3±1.5N	Not specified	Manual, Dip	14.0×4.7×5.0	—	22
SSSS925800	Horizontal	2.0	2	2	3±1.5N	Non shorting	Manual, Dip	11.5×7.2×5.0	—	23
SSSS923802	Horizontal	2.0	2	2	3±1.5N	Non shorting	Manual, Dip	11.5×7.2×5.0	—	24
SSSS928200	Horizontal	2.0	2	3	a, c → b 2±1N b → a, c 3±1.5N	Not specified	Manual, Dip	14.0×7.2×5.0	—	25
SSSS925701	Horizontal	2.0	2	3	a, c → b 2±1N b → a, c 3±1.5N	Not specified	Manual, Dip	14.0×7.2×5.0	—	26

5.0 (H) mm, 2.0mm-travel
SSSS9 Series

Note

1. This catalog shows only outline specifications. When using the products, please obtain formal specifications for supply.
2. Please place purchase orders per minimum order unit (integer).

■ Packing Specifications

Bulk

Products No.	Number of packages(pcs.)		Export package measurements (mm)
	1 case / Japan	1 case / export packing	
SSSS912000 SSSS910400 SSSS919500 SSSS918500 SSSS922000 SSSS912500 SSSS910800 SSSS919800 SSSS918700 SSSS922500 SSSS916900 SSSS915001 SSSS91B900 SSSS926400 SSSS916400 SSSS914503 SSSS91B600 SSSS91A601 SSSS925800 SSSS923802	1,000	5,000	400 x 270 x 290
SSSS921800 SSSS923200 SSSS920600 SSSS928500 SSSS928200 SSSS925701	800	4,000	400 x 270 x 290

Drawing No.1

■ Dimensions

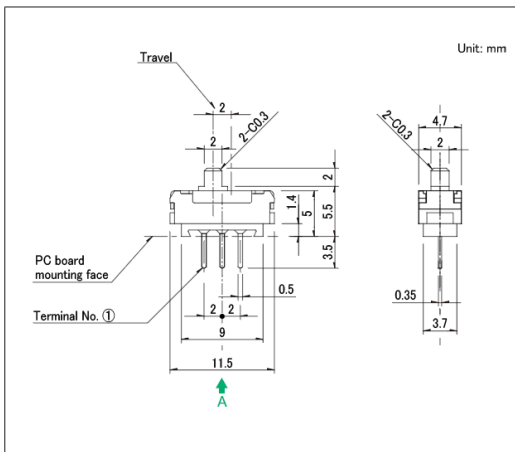

■ Mounting Hole Dimensions

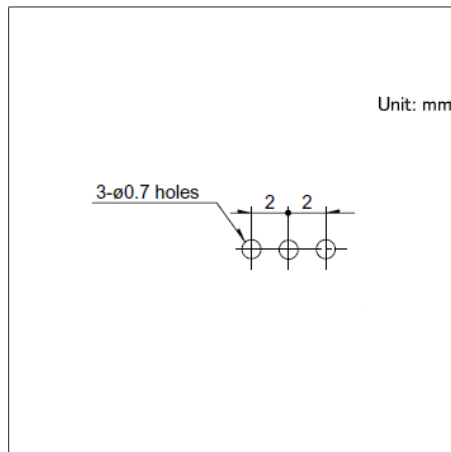

■ Circuit Diagram

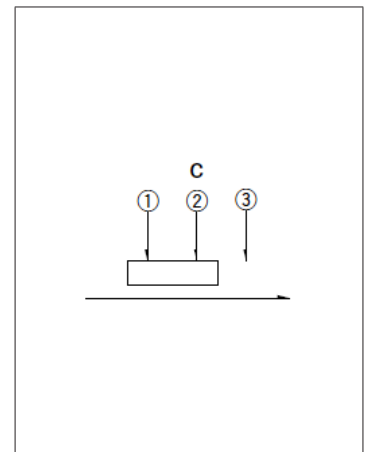

Viewed from direction A in the dimensions.

Switches Slide Switches

5.0 (H) mm, 2.0mm-travel
SSSS9 Series

Drawing No.2

■ Dimensions

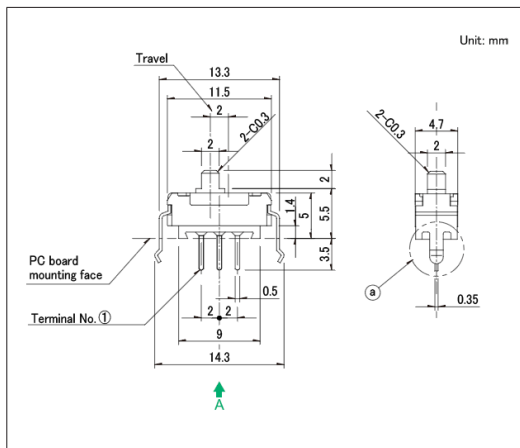

■ Mounting Hole Dimensions

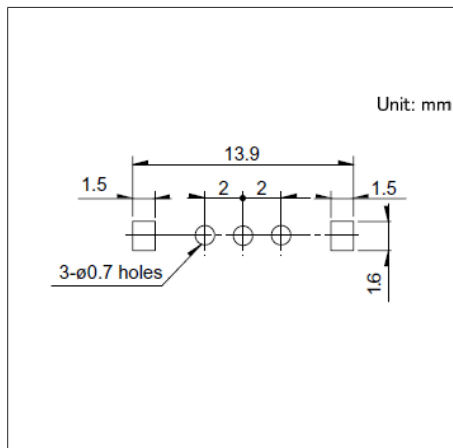

■ Circuit Diagram

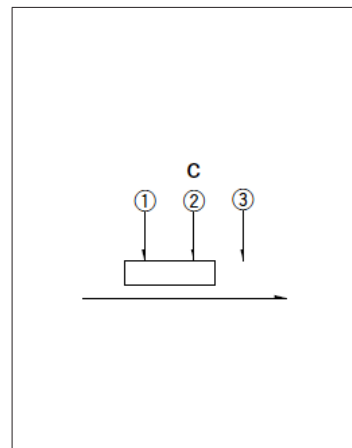

Viewed from direction A in the dimensions.

Drawing No.3

■ Dimensions

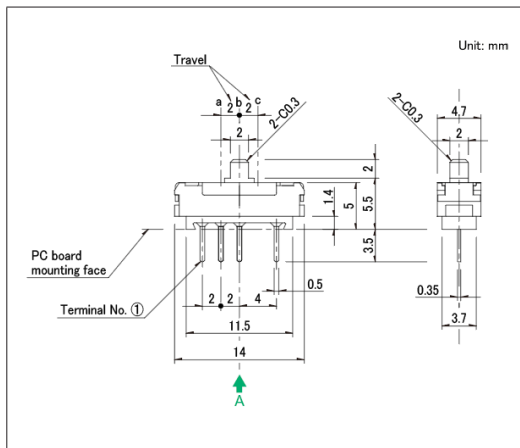

■ Mounting Hole Dimensions

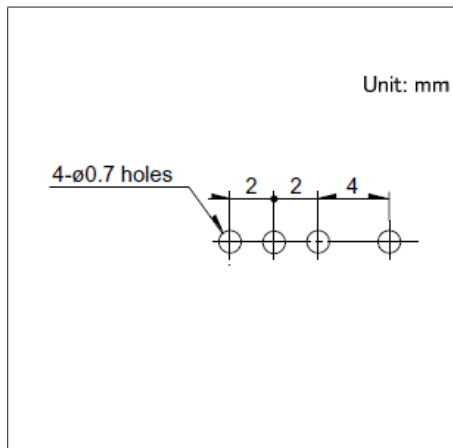

■ Circuit Diagram

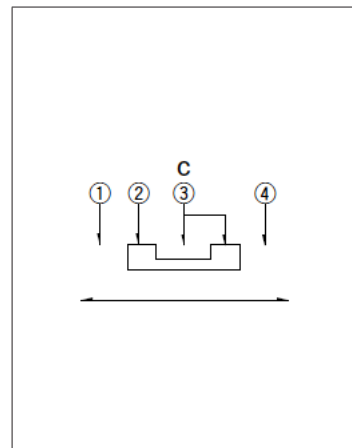

Viewed from direction A in the dimensions.

Drawing No.4

■ Dimensions

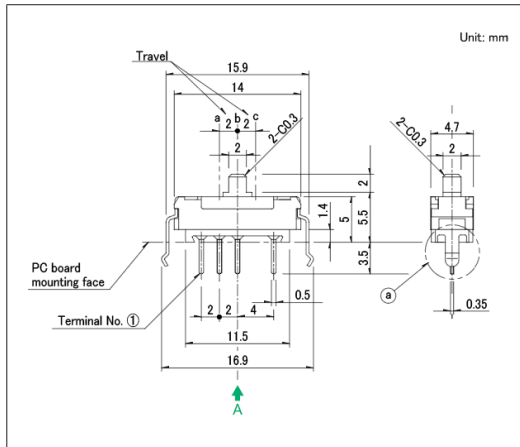

■ Mounting Hole Dimensions

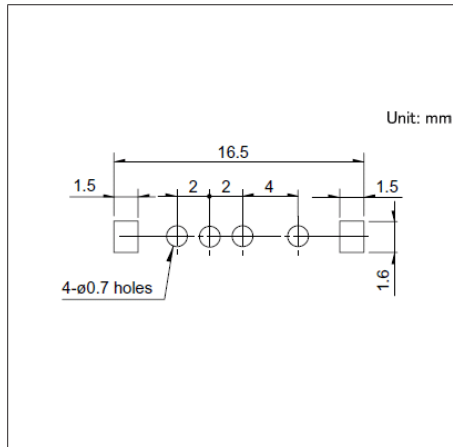

■ Circuit Diagram

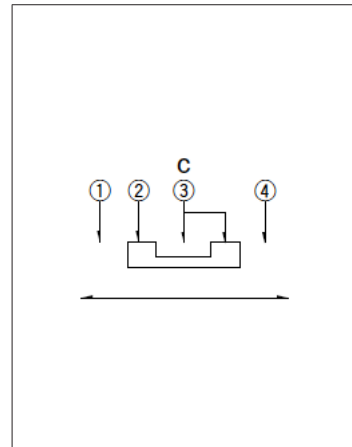

Viewed from direction A in the dimensions.

5.0 (H) mm, 2.0mm-travel
SSSS9 Series

Drawing No.5

■ Dimensions

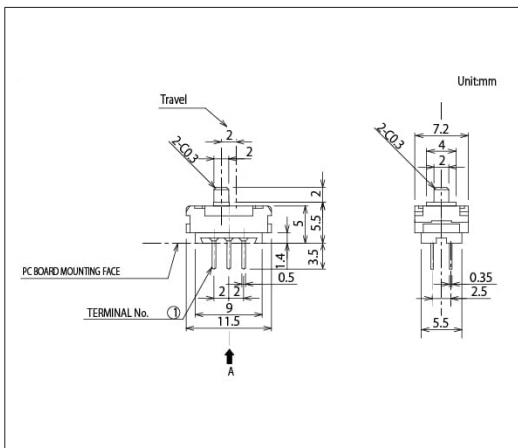

■ Mounting Hole Dimensions

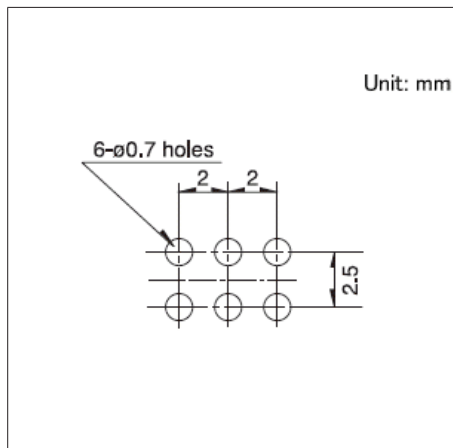

■ Circuit Diagram

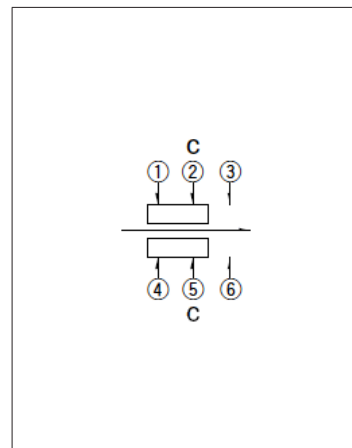

Viewed from direction A in the dimensions.

Drawing No.6

■ Dimensions

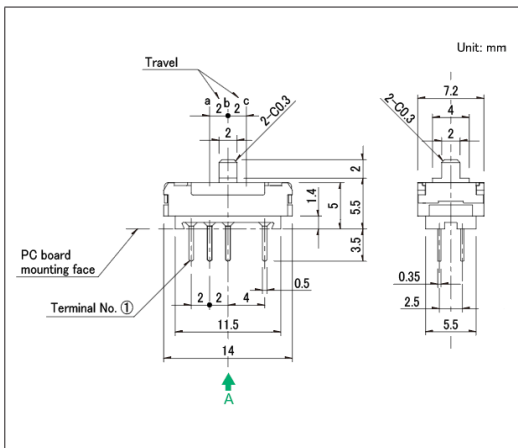

■ Mounting Hole Dimensions

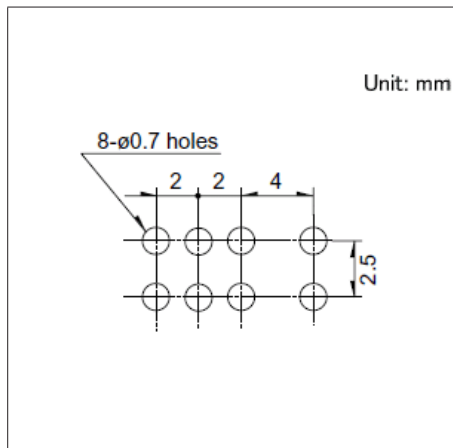

■ Circuit Diagram

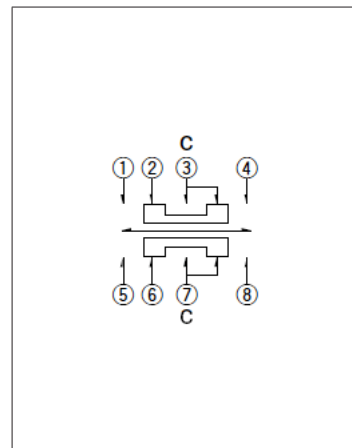

Viewed from direction A in the dimensions.

Drawing No.7

■ Dimensions

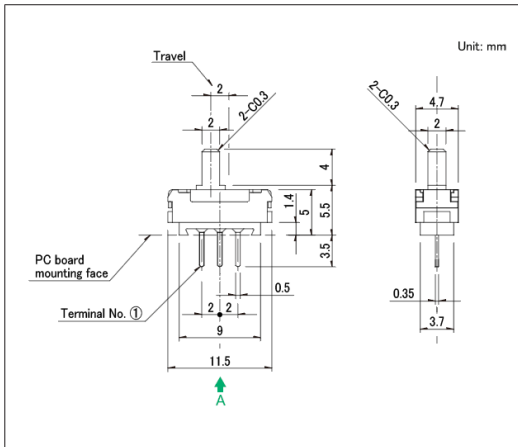

■ Mounting Hole Dimensions

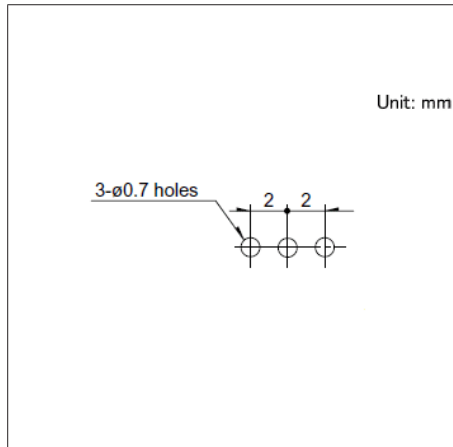

■ Circuit Diagram

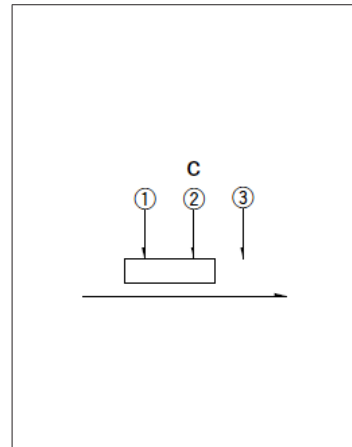

Viewed from direction A in the dimensions.

Switches Slide Switches

5.0 (H) mm, 2.0mm-travel
SSSS9 Series

Drawing No.8

■ Dimensions

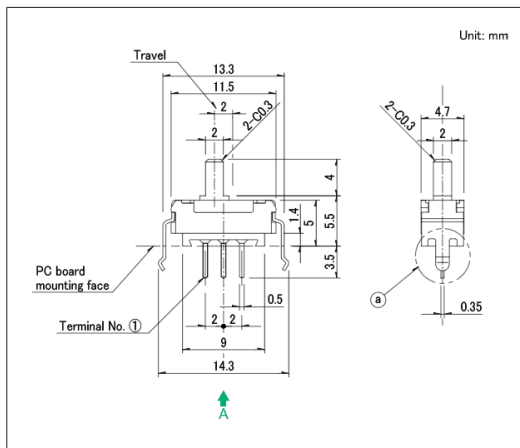

■ Mounting Hole Dimensions

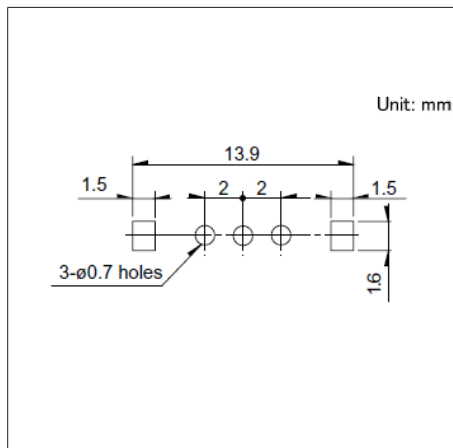

■ Circuit Diagram

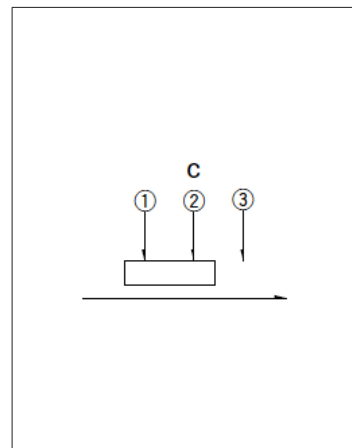

Viewed from direction A in the dimensions.

Drawing No.9

■ Dimensions

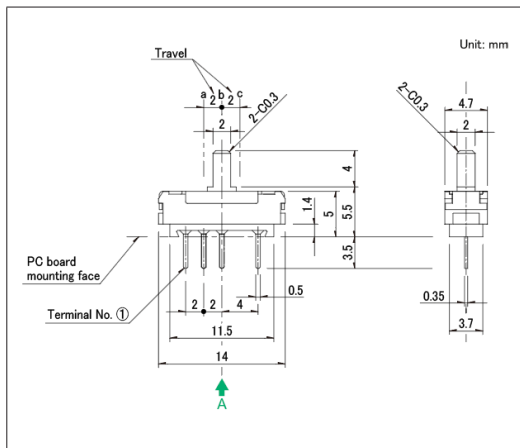

■ Mounting Hole Dimensions

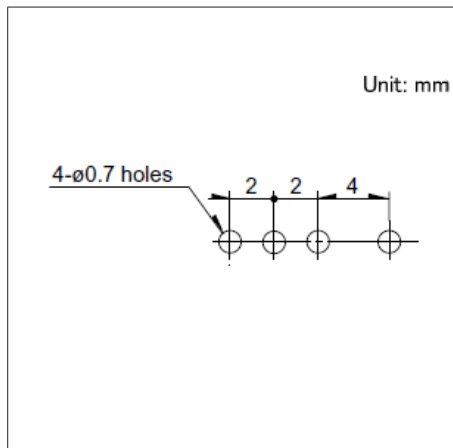

■ Circuit Diagram

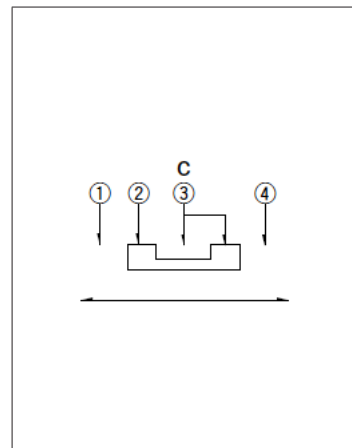

Viewed from direction A in the dimensions.

Drawing No.10

■ Dimensions

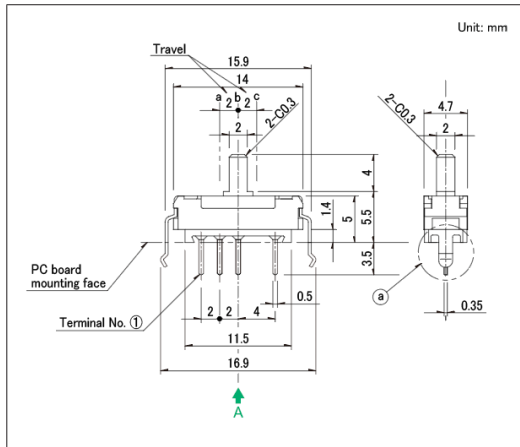

■ Mounting Hole Dimensions

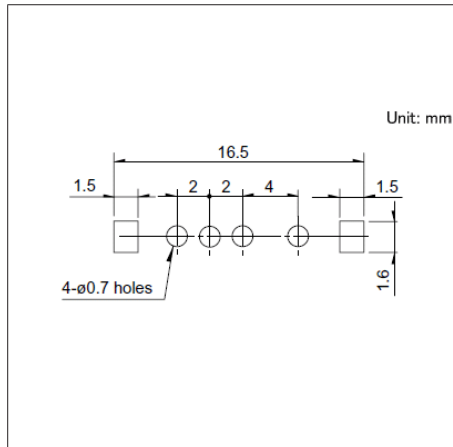

■ Circuit Diagram

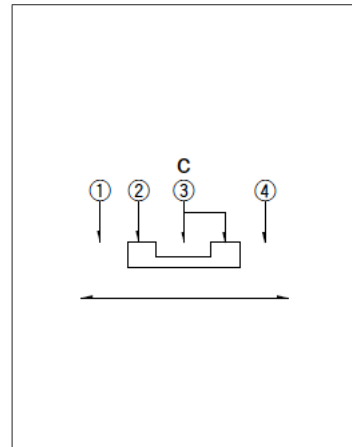

Viewed from direction A in the dimensions.

5.0 (H) mm, 2.0mm-travel
SSSS9 Series

Drawing No.11

■ Dimensions

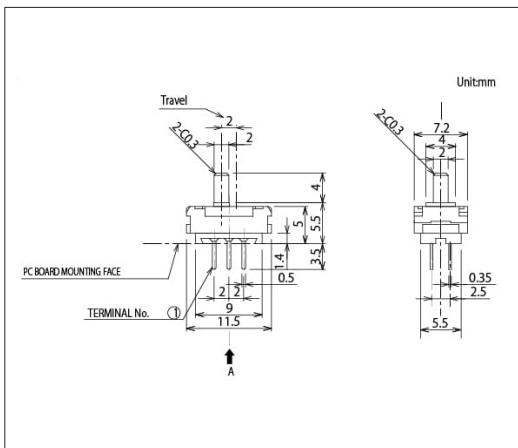

■ Mounting Hole Dimensions

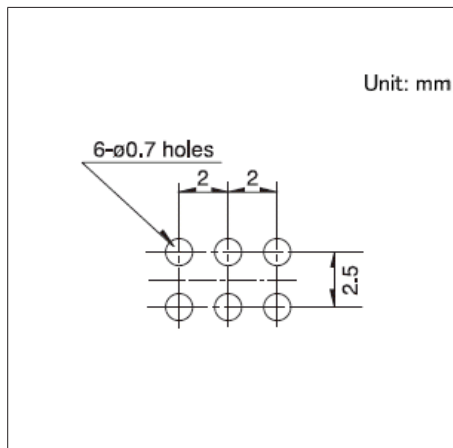

■ Circuit Diagram

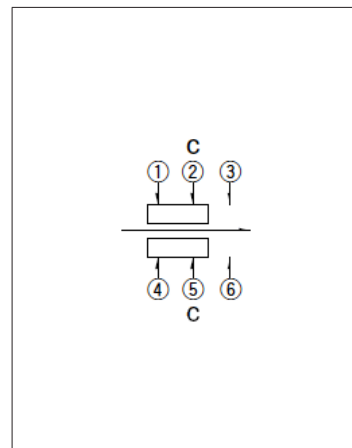

Viewed from direction A in the dimensions.

Drawing No.12

■ Dimensions

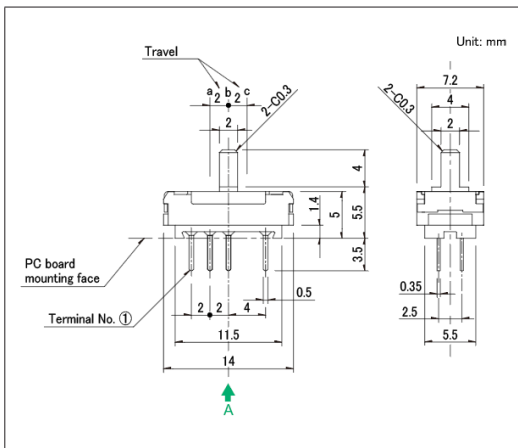

■ Mounting Hole Dimensions

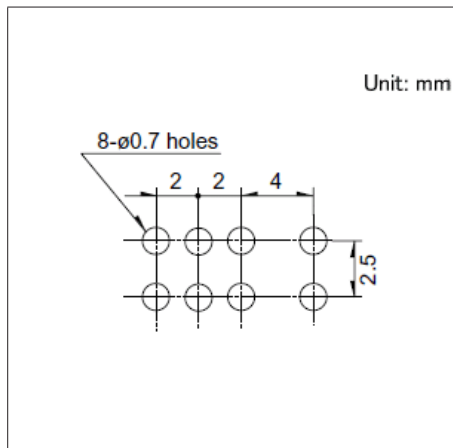

■ Circuit Diagram

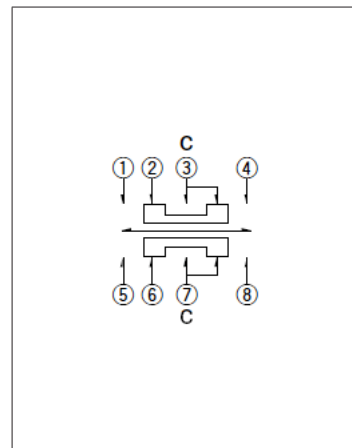

Viewed from direction A in the dimensions.

Drawing No.13

■ Dimensions

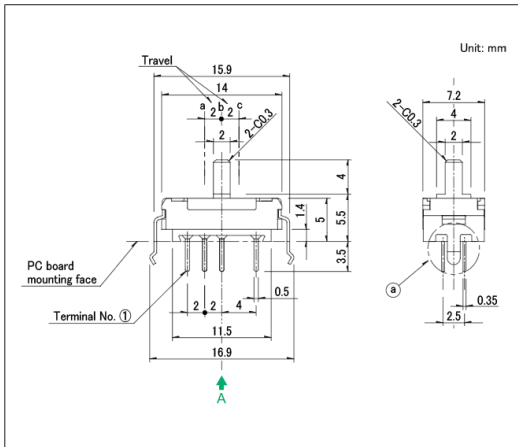

■ Mounting Hole Dimensions

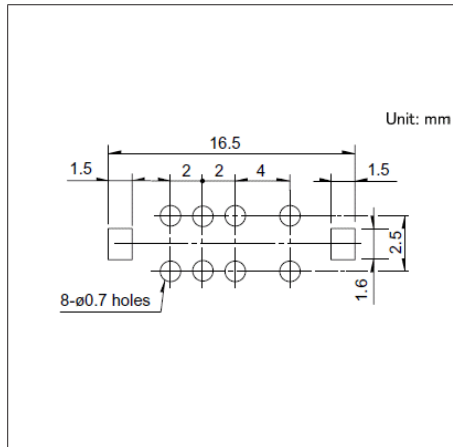

■ Circuit Diagram

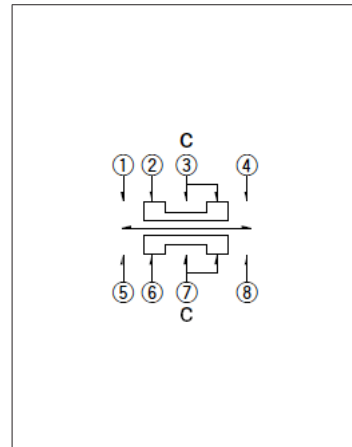

Viewed from direction A in the dimensions.

5.0 (H) mm, 2.0mm-travel
SSSS9 Series

Drawing No.26

■ Dimensions

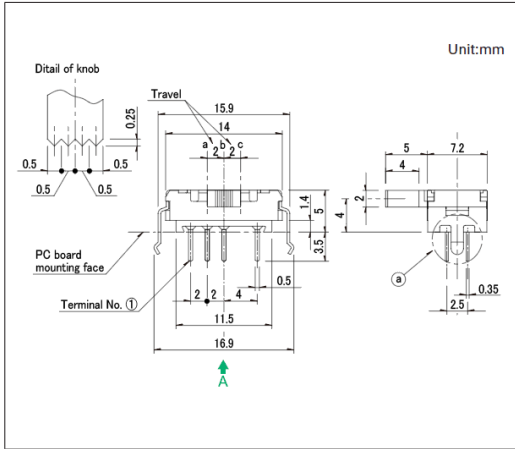

■ Mounting Hole Dimensions

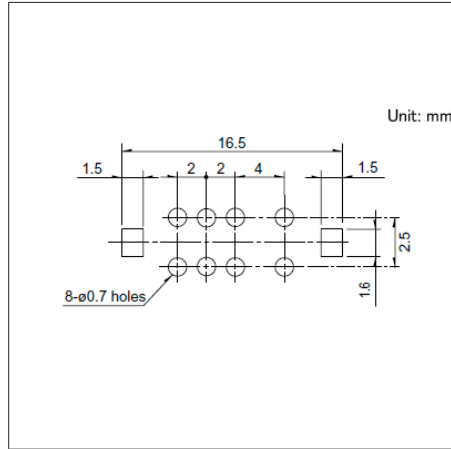

■ Circuit Diagram

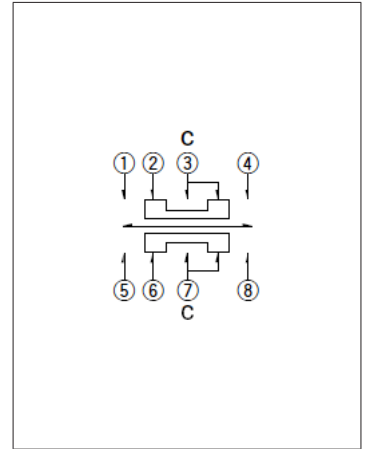

Viewed from direction A in the dimensions.

8.5 (H) mm, 2.0mm-travel

SSSF Series

Large general-purpose type with a proven track record across diverse industries.

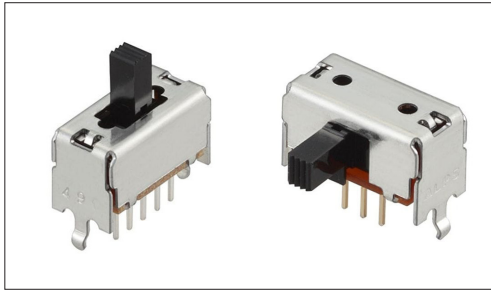

- Rating (max.)/(min.) (Resistive load): 0.1 A 30V DC/50 μ A 3V DC
- Contact resistance (Initial performance/After lifetime):
25m Ω max./65m Ω max.
- Operating life without load: 10,000 cycles 45m Ω max.
- Operating life with load (at max. rated load): 10,000 cycles 65m Ω max.

Applications: Audio_TV: Audio

■ Product List

Products No.	Actuator directions	Travel (mm)	Poles	Positions	Operating force	Changeover timing	Soldering	Dimensions (W×D×H) (mm)	Automotive	Drawing No.
SSSF011700	Vertical	2.0	1	2	Refer to the dimensions.	Non shorting	Manual, Dip	14.5×7.0×8.5	—	1
SSSF012100	Vertical	2.0	1	2	Refer to the dimensions.	Non shorting	Manual, Dip	14.5×7.0×8.5	—	2
SSSF014800	Vertical	2.0	1	3	Refer to the dimensions.	Non shorting	Manual, Dip	14.5×7.0×8.5	—	3
SSSF021500	Vertical	2.0	2	2	Refer to the dimensions.	Non shorting	Manual, Dip	14.5×7.0×8.5	—	4
SSSF021900	Vertical	2.0	2	2	Refer to the dimensions.	Non shorting	Manual, Dip	14.5×7.0×8.5	—	5
SSSF024800	Vertical	2.0	2	3	Refer to the dimensions.	Non shorting	Manual, Dip	14.5×7.0×8.5	—	6
SSSF025100	Vertical	2.0	2	3	Refer to the dimensions.	Non shorting	Manual, Dip	14.5×7.0×8.5	—	7
SSSF040800	Vertical	2.0	4	2	Refer to the dimensions.	Non shorting	Manual, Dip	16.5×7.0×8.5	—	8
SSSF111800	Horizontal	2.0	1	2	Refer to the dimensions.	Non shorting	Manual, Dip	14.5×7.0×8.5	—	9
SSSF112500	Horizontal	2.0	1	2	Refer to the dimensions.	Non shorting	Manual, Dip	14.5×7.0×8.5	—	10
SSSF114900	Horizontal	2.0	1	3	Refer to the dimensions.	Non shorting	Manual, Dip	14.5×7.0×8.5	—	11
SSSF115300	Horizontal	2.0	1	3	Refer to the dimensions.	Non shorting	Manual, Dip	14.5×7.0×8.5	—	12
SSSF121900	Horizontal	2.0	2	2	Refer to the dimensions.	Non shorting	Manual, Dip	14.5×7.0×8.5	—	13
SSSF122400	Horizontal	2.0	2	2	Refer to the dimensions.	Non shorting	Manual, Dip	14.5×7.0×8.5	—	14
SSSF125300	Horizontal	2.0	2	3	Refer to the dimensions.	Non shorting	Manual, Dip	14.5×7.0×8.5	—	15
SSSF125800	Horizontal	2.0	2	3	Refer to the dimensions.	Non shorting	Manual, Dip	14.5×7.0×8.5	—	16
SSSF141000	Horizontal	2.0	4	2	Refer to the dimensions.	Non shorting	Manual, Dip	16.5×7.0×8.5	—	17
SSSF141300	Horizontal	2.0	4	2	Refer to the dimensions.	Non shorting	Manual, Dip	16.5×7.0×8.5	—	18

⚠ Note

1. This catalog shows only outline specifications. When using the products, please obtain formal specifications for supply.
2. Please place purchase orders per minimum order unit (integer).

8.5 (H) mm, 2.0mm-travel
SSSF Series

■ Packing Specifications

Bulk

Products No.	Number of packages (pcs.)		Export package measurements (mm)
	1 case / Japan	1 case / export packing	
SSSF011700 SSSF012100 SSSF014800 SSSF021500 SSSF021900 SSSF024800 SSSF025100 SSSF040800 SSSF112500 SSSF115300 SSSF122400 SSSF125800 SSSF141000 SSSF141300	800	4,000	400 x 270 x 290
SSSF111800 SSSF114900 SSSF121900 SSSF125300	600	3,000	400 x 270 x 290

Drawing No.1

■ Dimensions

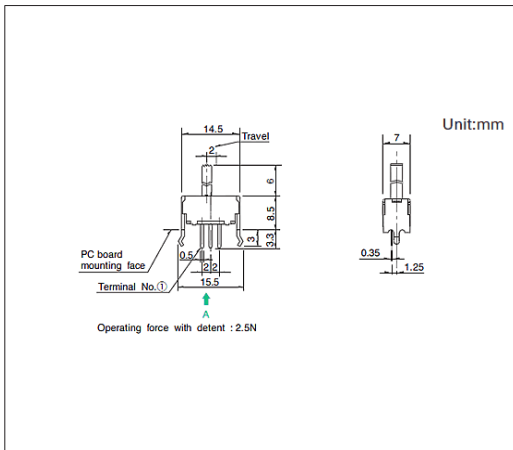

■ Mounting Hole Dimensions

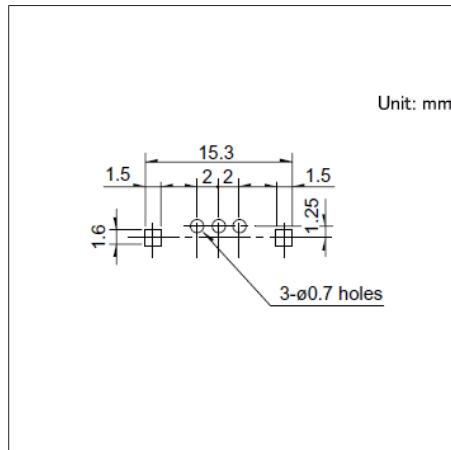

■ Circuit Diagram

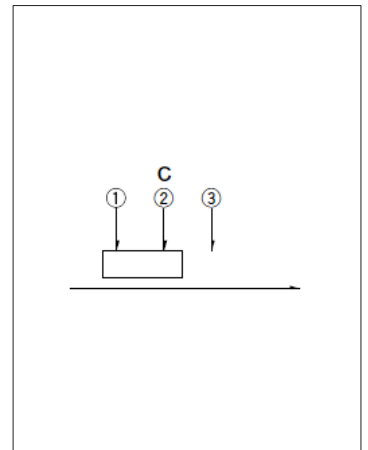

Viewed from direction A in the dimensions.

Drawing No.2

■ Dimensions

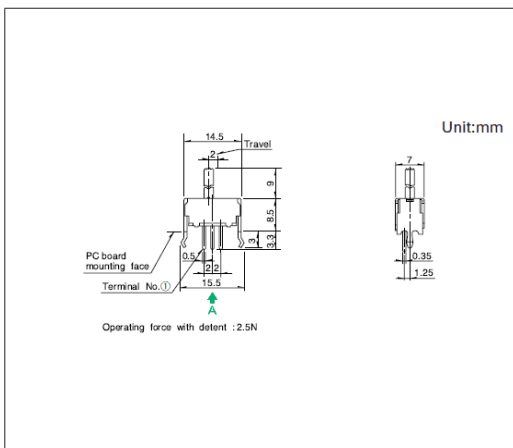

■ Mounting Hole Dimensions

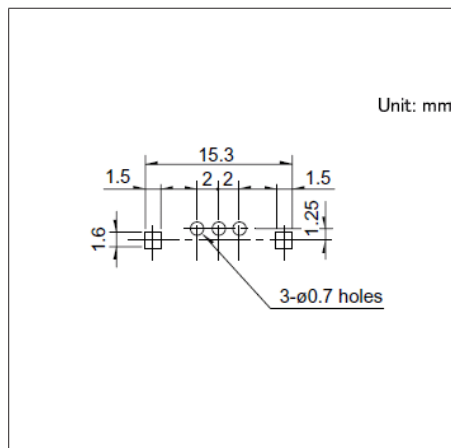

■ Circuit Diagram

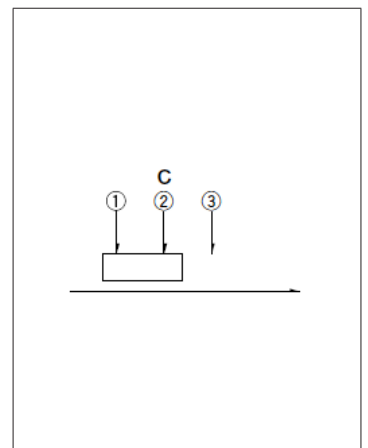

Viewed from direction A in the dimensions.

Switches Slide Switches

8.5 (H) mm, 2.0mm-travel
SSSF Series

Drawing No.3

■ Dimensions

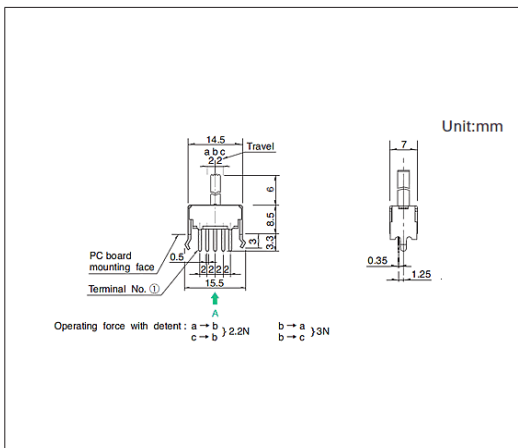

■ Mounting Hole Dimensions

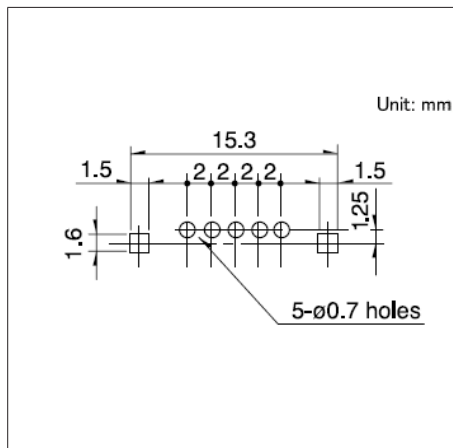

■ Circuit Diagram

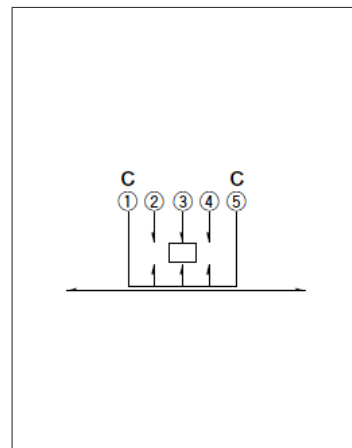

Viewed from direction A in the dimensions.

Drawing No.4

■ Dimensions

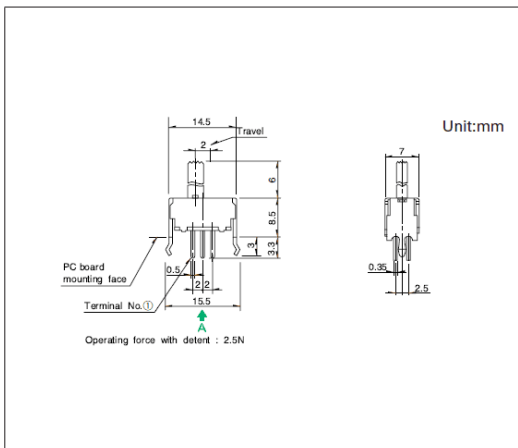

■ Mounting Hole Dimensions

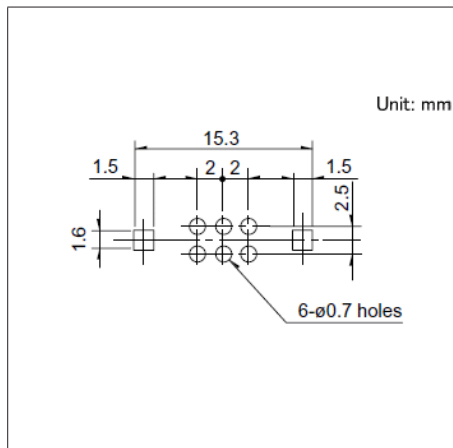

■ Circuit Diagram

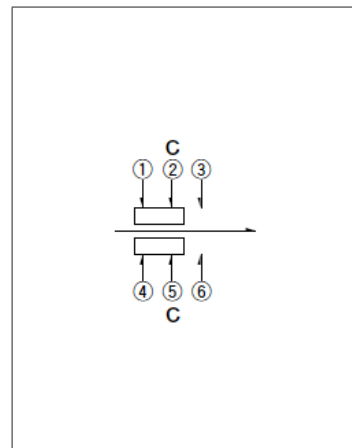

Viewed from direction A in the dimensions.

Drawing No.5

■ Dimensions

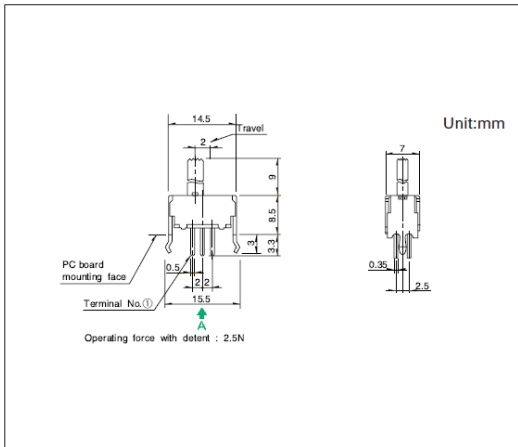

■ Mounting Hole Dimensions

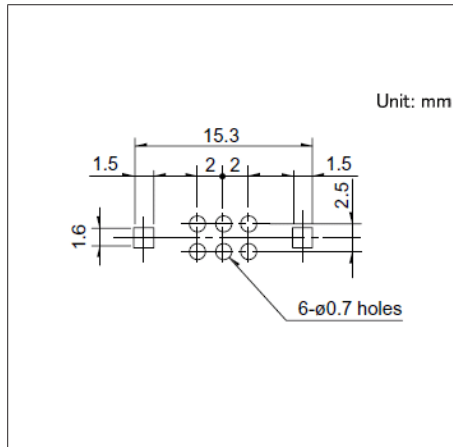

■ Circuit Diagram

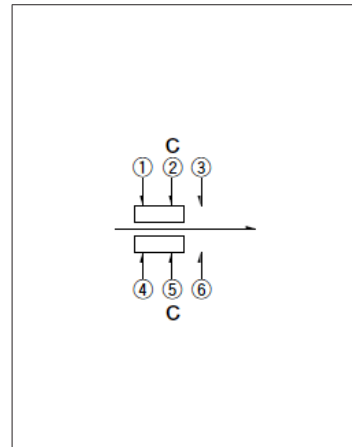

Viewed from direction A in the dimensions.

Switches Slide Switches

8.5 (H) mm, 2.0mm-travel
SSSF Series

Drawing No.6

■ Dimensions

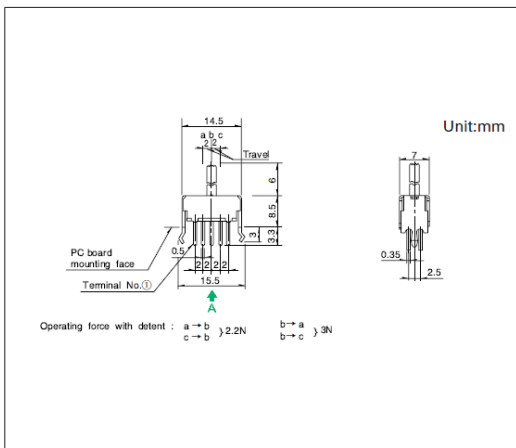

■ Mounting Hole Dimensions

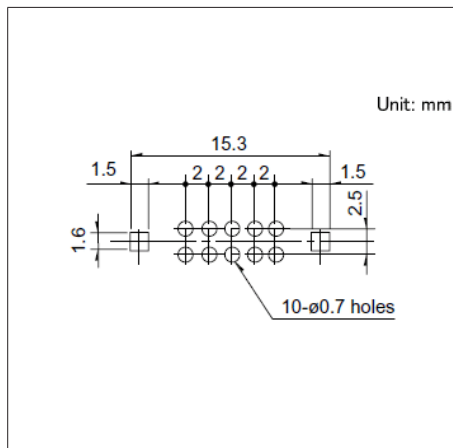

■ Circuit Diagram

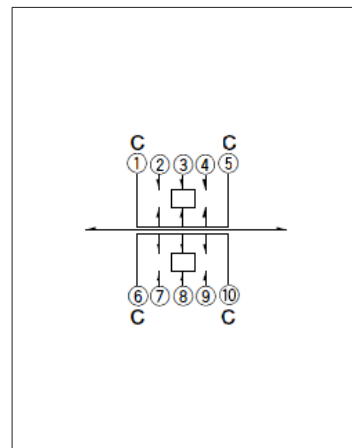

Viewed from direction A in the dimensions.

Drawing No.7

■ Dimensions

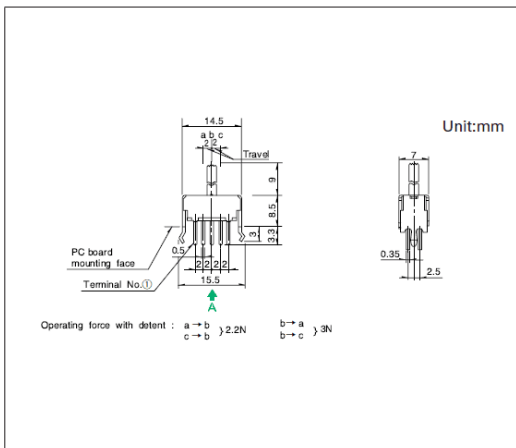

■ Mounting Hole Dimensions

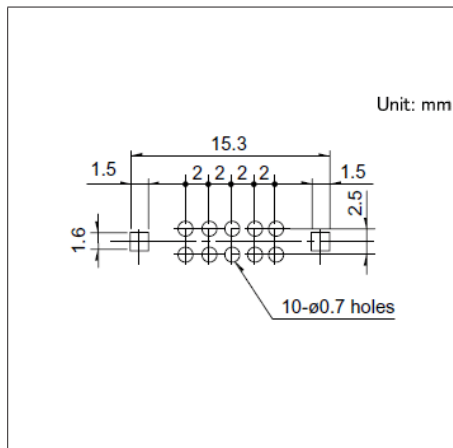

■ Circuit Diagram

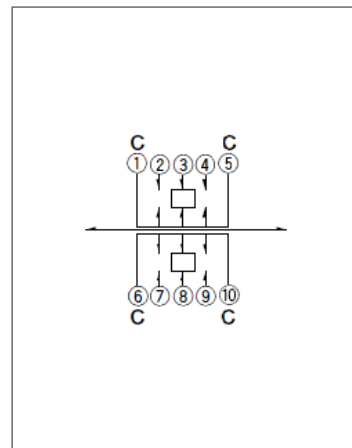

Viewed from direction A in the dimensions.

Drawing No.8

■ Dimensions

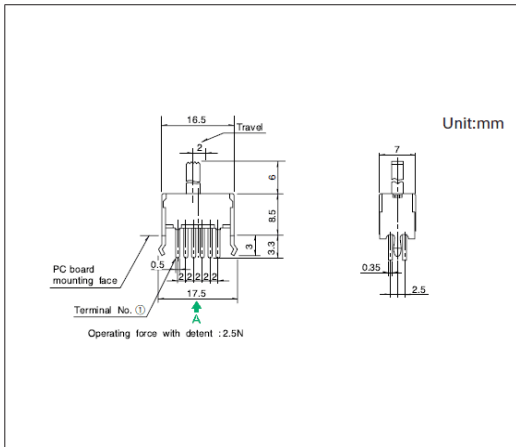

■ Mounting Hole Dimensions

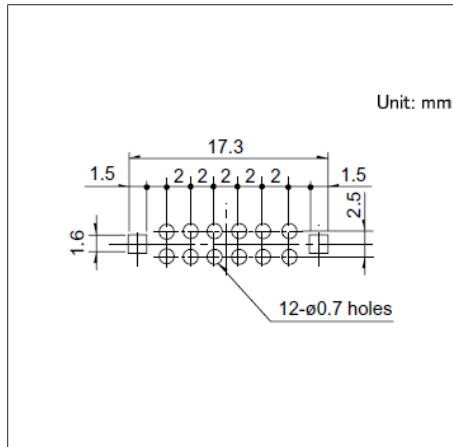

■ Circuit Diagram

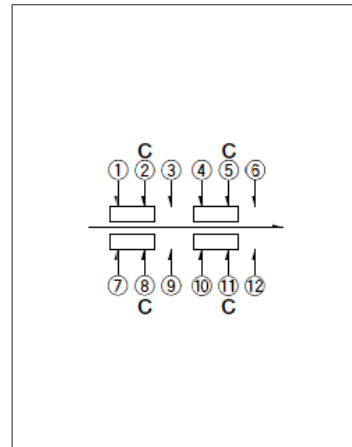

Viewed from direction A in the dimensions.

8.5 (H) mm, 2.0mm-travel
SSSF Series

Drawing No.9

■ Dimensions

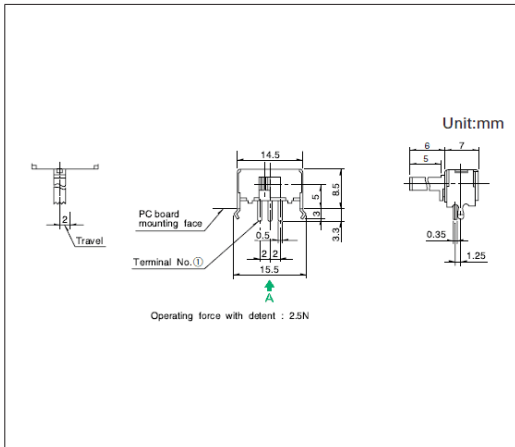

■ Mounting Hole Dimensions

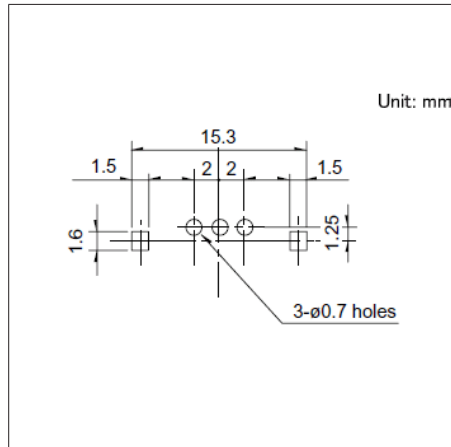

■ Circuit Diagram

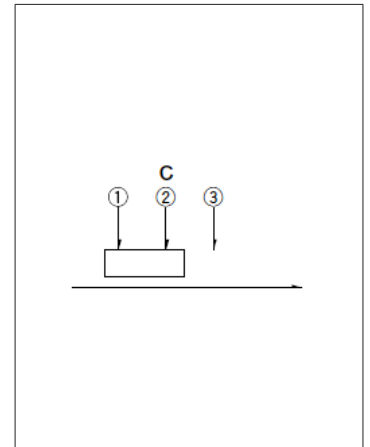

Viewed from direction A in the dimensions.

Drawing No.10

■ Dimensions

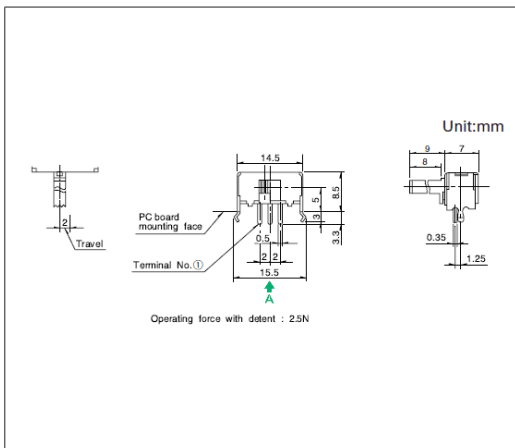

■ Mounting Hole Dimensions

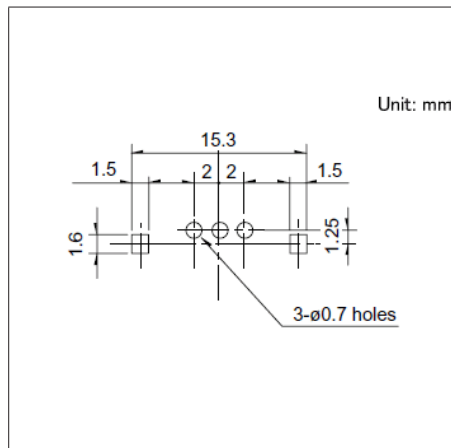

■ Circuit Diagram

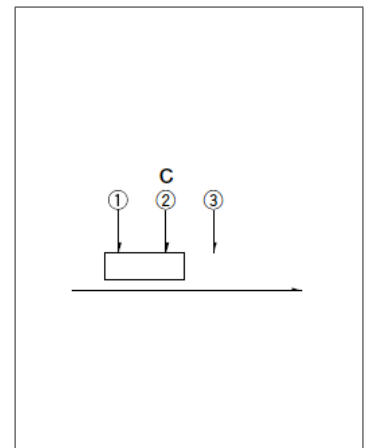

Viewed from direction A in the dimensions.

Drawing No.11

■ Dimensions

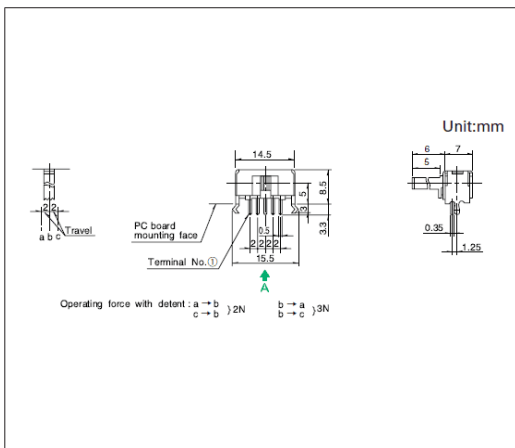

■ Mounting Hole Dimensions

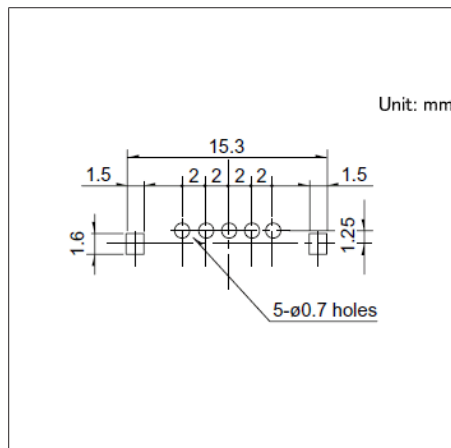

■ Circuit Diagram

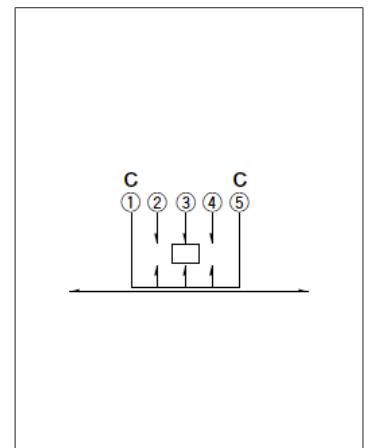

Viewed from direction A in the dimensions.

Switches Slide Switches

8.5 (H) mm, 2.0mm-travel
SSSF Series

Drawing No.12

■ Dimensions

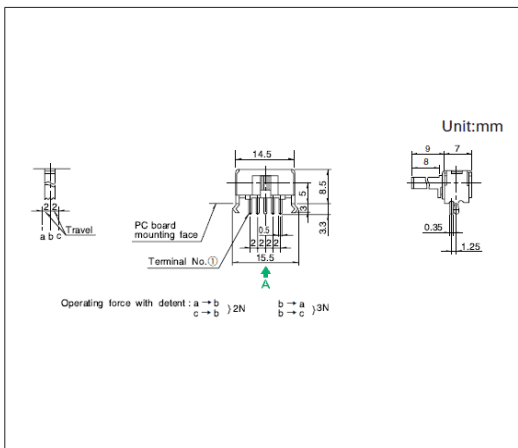

■ Mounting Hole Dimensions

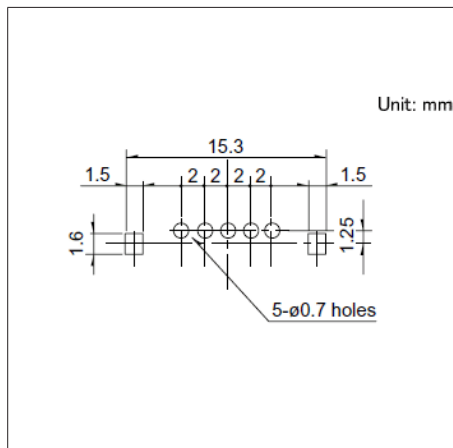

■ Circuit Diagram

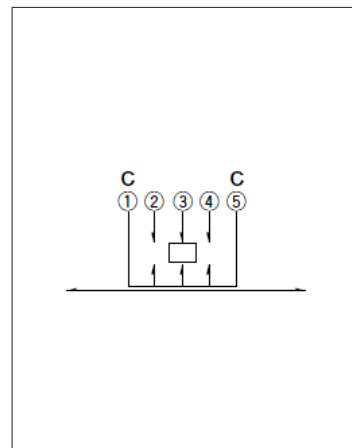

Viewed from direction A in the dimensions.

Drawing No.13

■ Dimensions

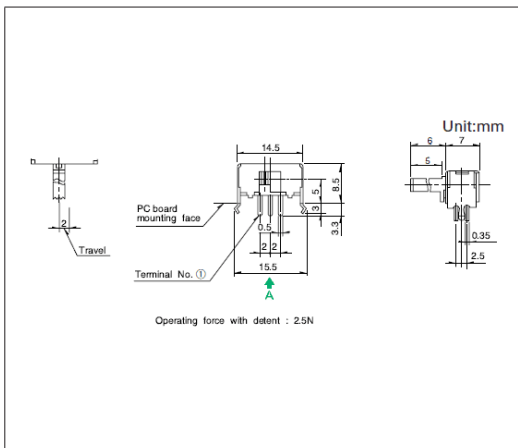

■ Mounting Hole Dimensions

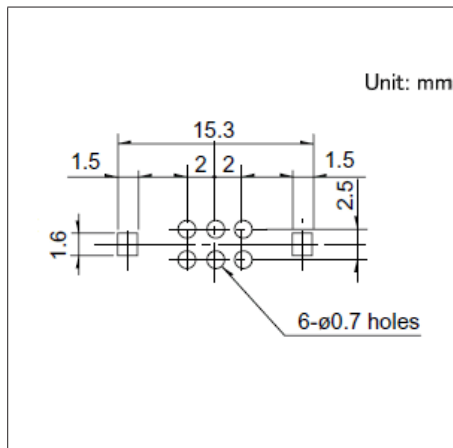

■ Circuit Diagram

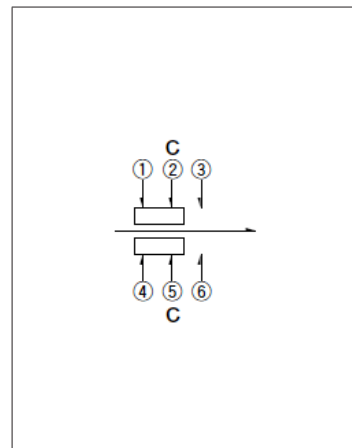

Viewed from direction A in the dimensions.

Drawing No.14

■ Dimensions

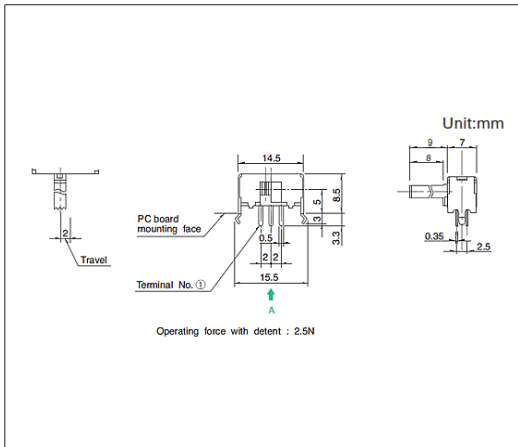

■ Mounting Hole Dimensions

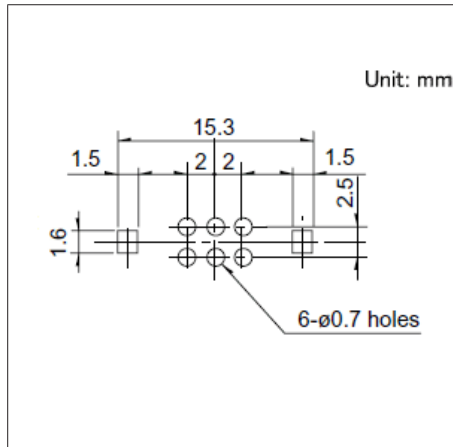

■ Circuit Diagram

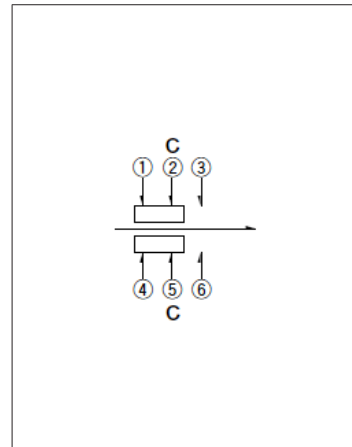

Viewed from direction A in the dimensions.

8.5 (H) mm, 2.0mm-travel
SSSF Series

Drawing No.15

■ Dimensions

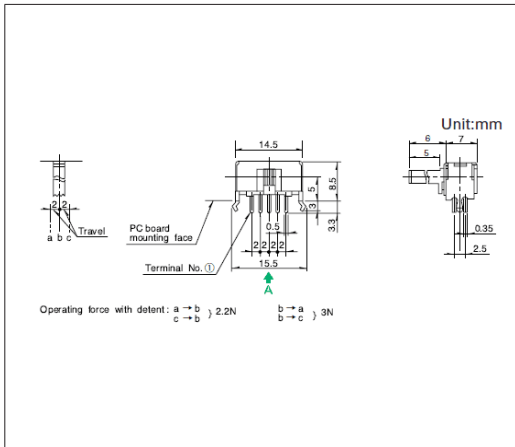

■ Mounting Hole Dimensions

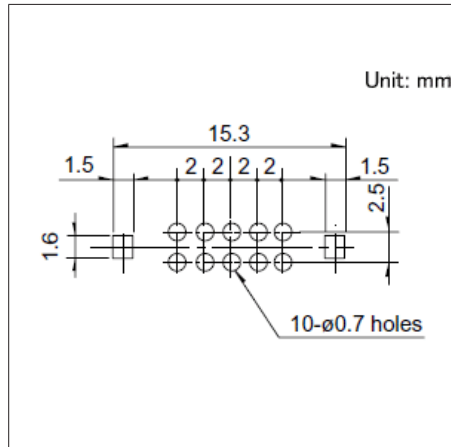

■ Circuit Diagram

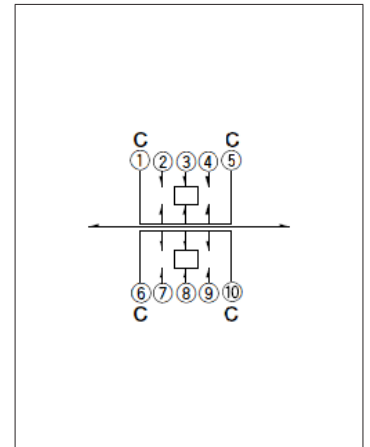

Viewed from direction A in the dimensions.

Drawing No.16

■ Dimensions

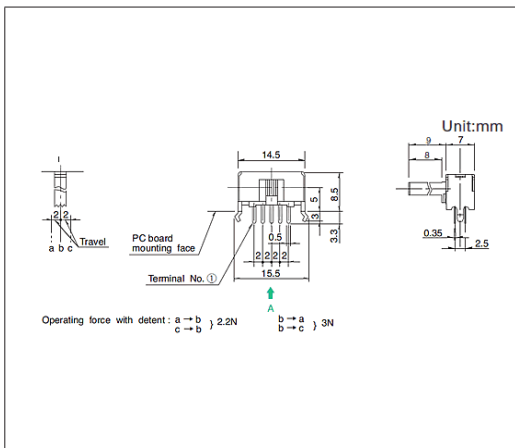

■ Mounting Hole Dimensions

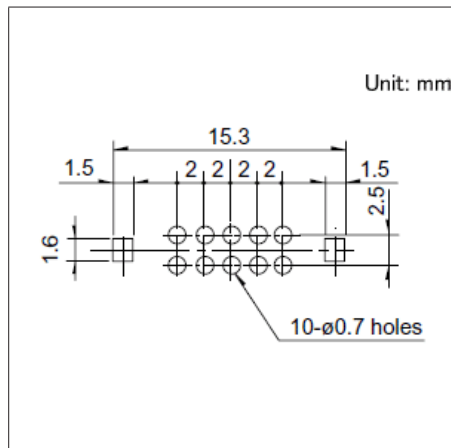

■ Circuit Diagram

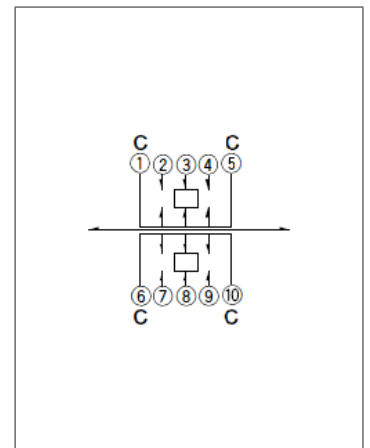

Viewed from direction A in the dimensions.

Drawing No.17

■ Dimensions

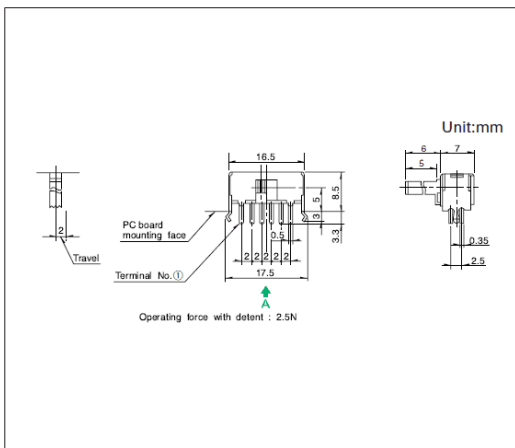

■ Mounting Hole Dimensions

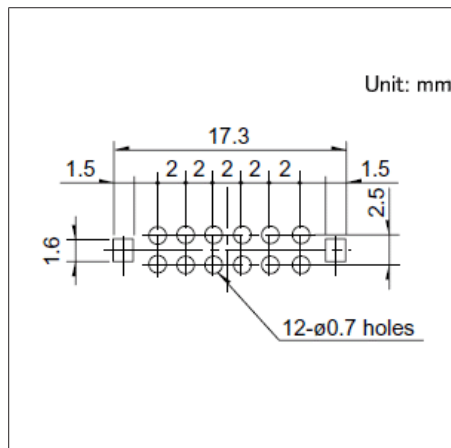

■ Circuit Diagram

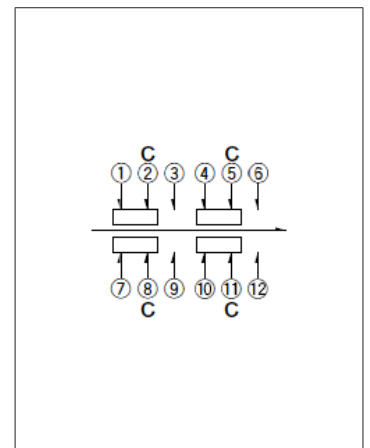

Viewed from direction A in the dimensions.

8.5 (H) mm, 2.0mm-travel
SSSF Series

Drawing No.18

■ Dimensions

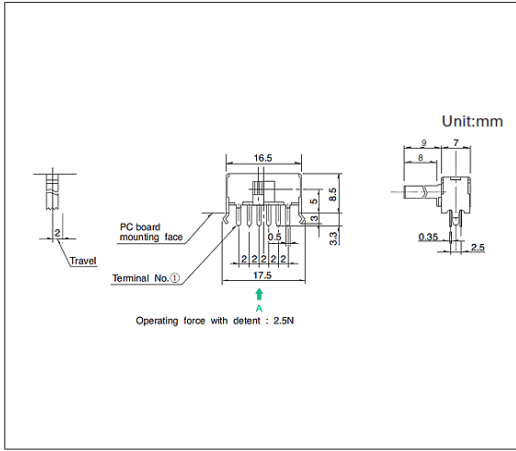

■ Mounting Hole Dimensions

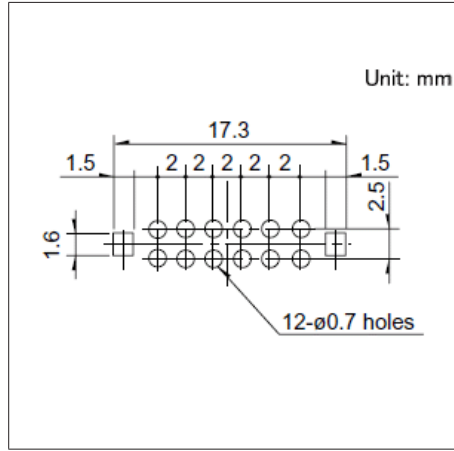

■ Circuit Diagram

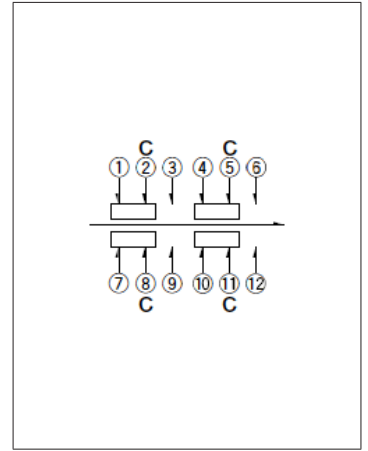

Viewed from direction A in the dimensions.

8.5 (H) mm, 3.0mm-travel

SSSU Series

Large general-purpose type with a wide variety of knob options.

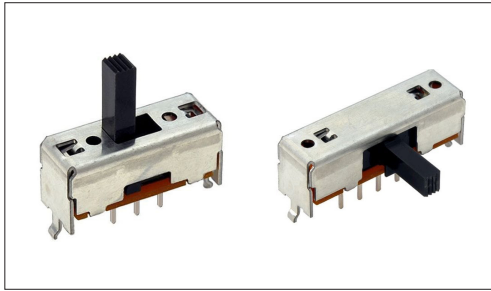

- Rating (max.)/(min.) (Resistive load): 0.1 A 30V DC/50 μ A 3V DC
- Contact resistance (Initial performance/After lifetime):
25m Ω max./65m Ω max.
- Operating life without load: 10,000 cycles 45m Ω max.
- Operating life with load (at max. rated load): 10,000 cycles 65m Ω max.

Applications: Audio_TV: Audio

■ Product List

Products No.	Actuator directions	Travel (mm)	Poles	Positions	Operating force	Changeover timing	Soldering	Dimensions (WxDxH) (mm)	Automotive	Drawing No.
SSSU011700	Vertical	3.0	1	2	Refer to the dimensions.	Non shorting	Manual, Dip	18.5×7.0×8.5	—	1
SSSU012200	Vertical	3.0	1	2	Refer to the dimensions.	Non shorting	Manual, Dip	18.5×7.0×8.5	—	2
SSSU014800	Vertical	3.0	1	3	Refer to the dimensions.	Non shorting	Manual, Dip	24.5×7.0×8.5	—	3
SSSU015100	Vertical	3.0	1	3	Refer to the dimensions.	Non shorting	Manual, Dip	24.5×7.0×8.5	—	4
SSSU022400	Vertical	3.0	2	2	Refer to the dimensions.	Non shorting	Manual, Dip	18.5×7.0×8.5	—	5
SSSU022800	Vertical	3.0	2	2	Refer to the dimensions.	Non shorting	Manual, Dip	18.5×7.0×8.5	—	6
SSSU025800	Vertical	3.0	2	3	Refer to the dimensions.	Non shorting	Manual, Dip	24.5×7.0×8.5	—	7
SSSU026300	Vertical	3.0	2	3	Refer to the dimensions.	Non shorting	Manual, Dip	24.5×7.0×8.5	—	8
SSSU041700	Vertical	3.0	4	2	Refer to the dimensions.	Non shorting	Manual, Dip	21.5×7.0×8.5	—	9
SSSU042100	Vertical	3.0	4	2	Refer to the dimensions.	Non shorting	Manual, Dip	21.5×7.0×8.5	—	10
SSSU111400	Horizontal	3.0	1	2	Refer to the dimensions.	Non shorting	Manual, Dip	18.5×7.0×8.5	—	11
SSSU113200	Horizontal	3.0	1	3	Refer to the dimensions.	Non shorting	Manual, Dip	24.5×7.0×8.5	—	12
SSSU121700	Horizontal	3.0	2	2	Refer to the dimensions.	Non shorting	Manual, Dip	18.5×7.0×8.5	—	13
SSSU122200	Horizontal	3.0	2	2	Refer to the dimensions.	Non shorting	Manual, Dip	18.5×7.0×8.5	—	14
SSSU124900	Horizontal	3.0	2	3	Refer to the dimensions.	Non shorting	Manual, Dip	24.5×7.0×8.5	—	15

⚠ Note

1. This catalog shows only outline specifications. When using the products, please obtain formal specifications for supply.
2. Please place purchase orders per minimum order unit (integer).

8.5 (H) mm, 3.0mm-travel
SSSU Series

■ Packing Specifications

Bulk

Products No.	Number of packages (pcs.)		Export package measurements (mm)
	1 case / Japan	1 case / export packing	
SSSU011700 SSSU012200 SSSU022400 SSSU022800 SSSU124900	400	2,000	400 x 270 x 290
SSSU014800 SSSU015100 SSSU025800 SSSU026300 SSSU041700 SSSU042100 SSSU113200	500	2,500	400 x 270 x 290
SSSU111400 SSSU121700 SSSU122200	700	3,500	400 x 270 x 290

Drawing No.1

■ Dimensions

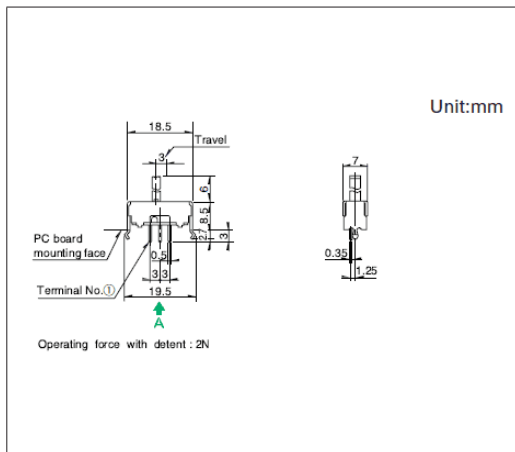

■ Mounting Hole Dimensions

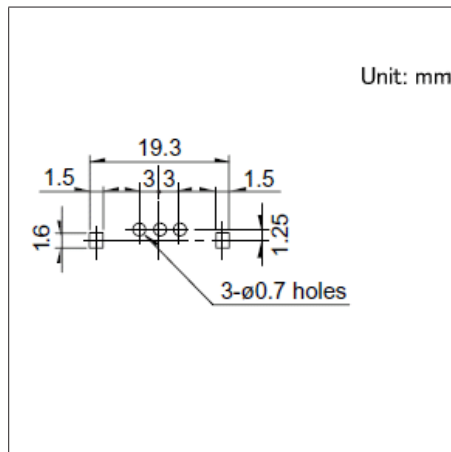

■ Circuit Diagram

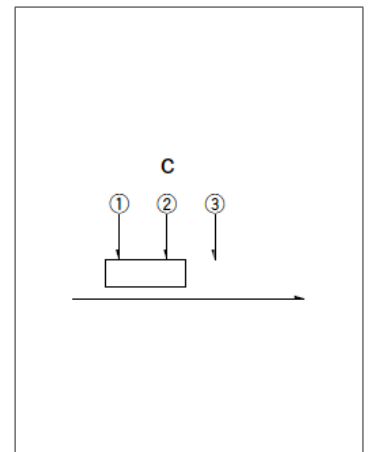

Viewed from direction A in the dimensions.

Drawing No.2

■ Dimensions

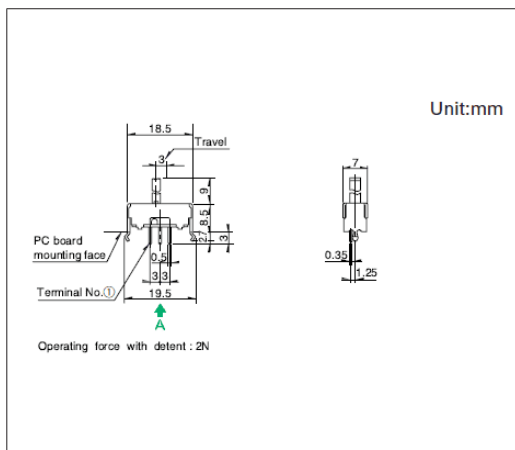

■ Mounting Hole Dimensions

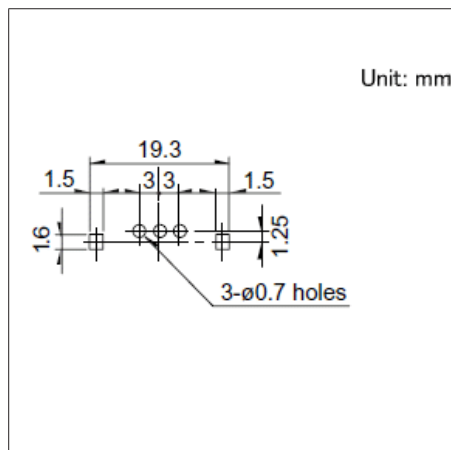

■ Circuit Diagram

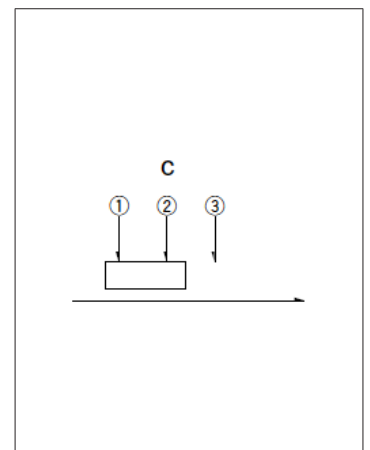

Viewed from direction A in the dimensions.

Switches Slide Switches

8.5 (H) mm, 3.0mm-travel
SSSU Series

Drawing No.3

■ Dimensions

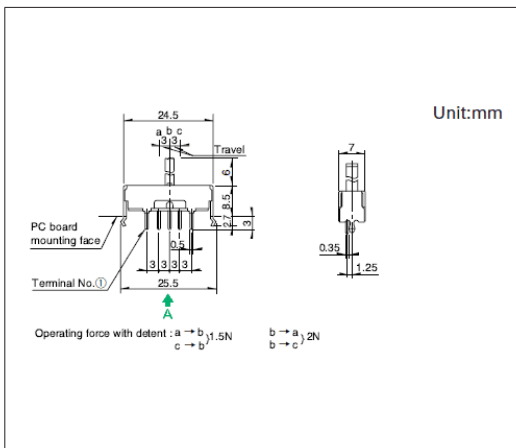

■ Mounting Hole Dimensions

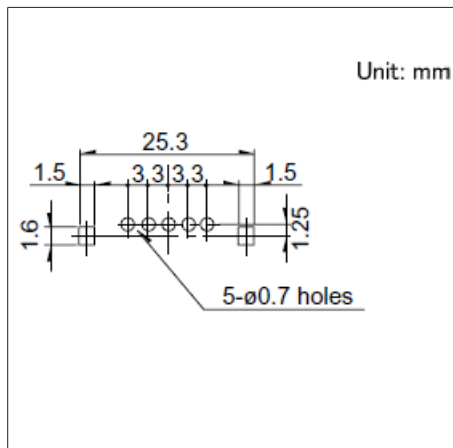

■ Circuit Diagram

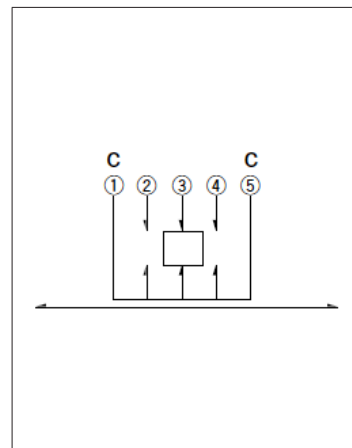

Viewed from direction A in the dimensions.

Drawing No.4

■ Dimensions

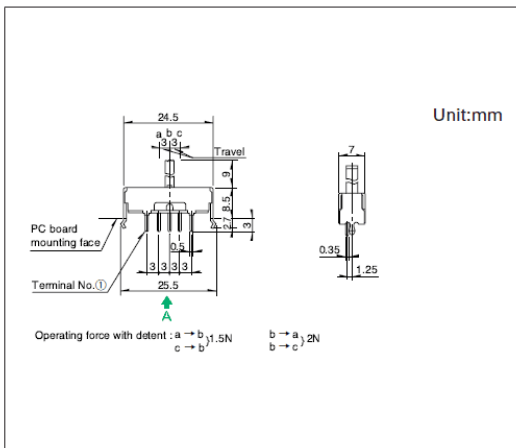

■ Mounting Hole Dimensions

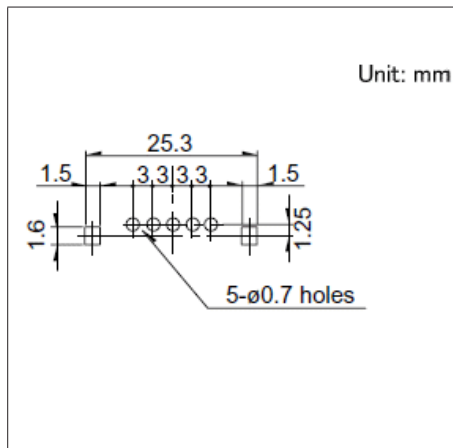

■ Circuit Diagram

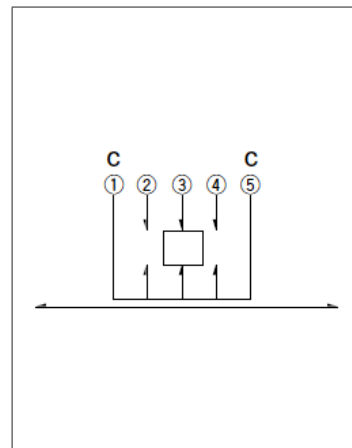

Viewed from direction A in the dimensions.

Drawing No.5

■ Dimensions

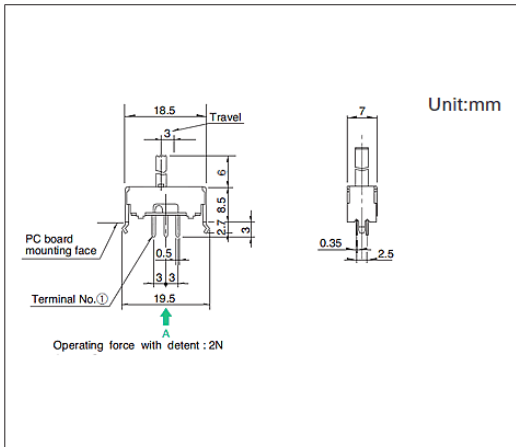

■ Mounting Hole Dimensions

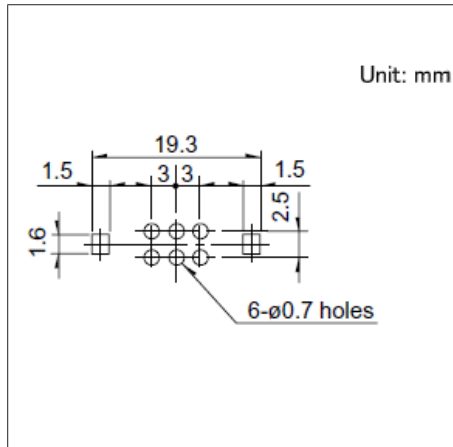

■ Circuit Diagram

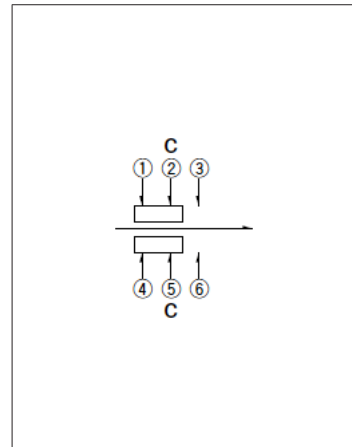

Viewed from direction A in the dimensions.

8.5 (H) mm, 3.0mm-travel
SSSU Series

Drawing No.6

■ Dimensions

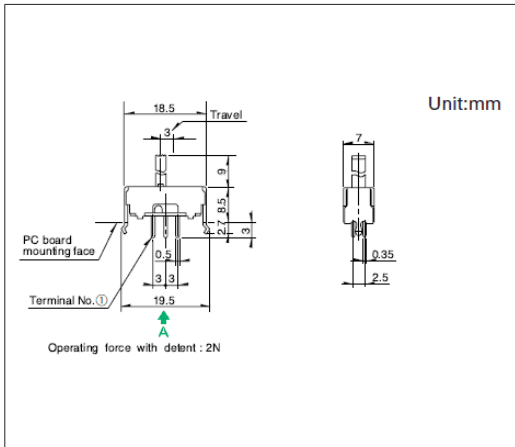

■ Mounting Hole Dimensions

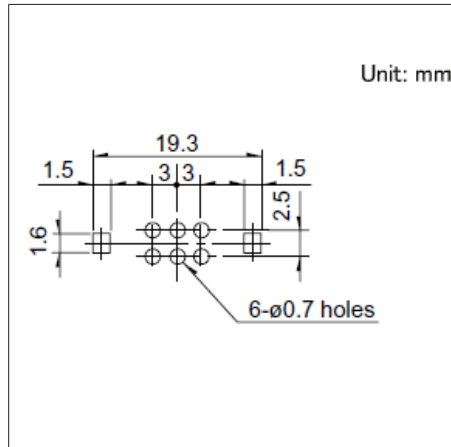

■ Circuit Diagram

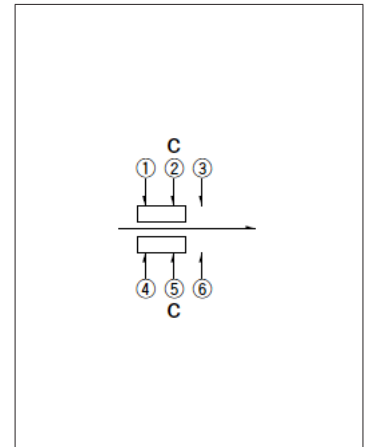

Viewed from direction A in the dimensions.

Drawing No.7

■ Dimensions

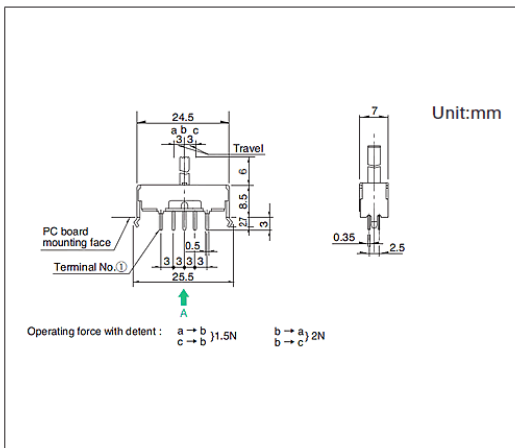

■ Mounting Hole Dimensions

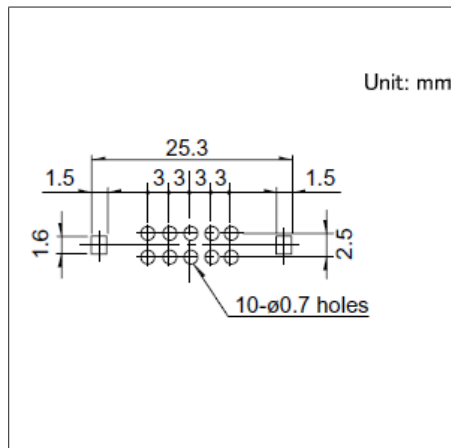

■ Circuit Diagram

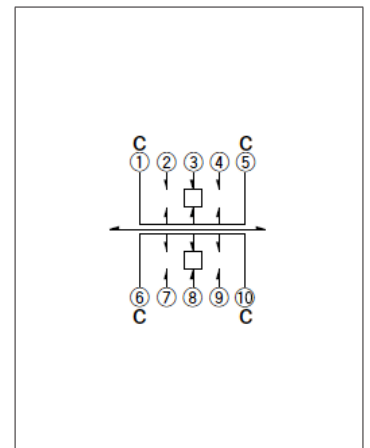

Viewed from direction A in the dimensions.

Drawing No.8

■ Dimensions

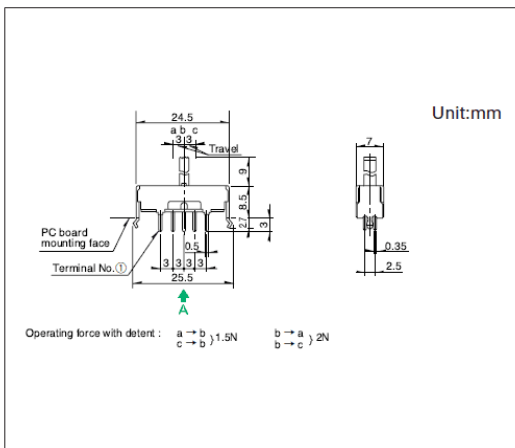

■ Mounting Hole Dimensions

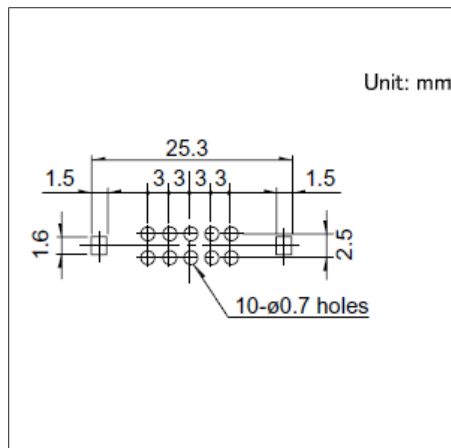

■ Circuit Diagram

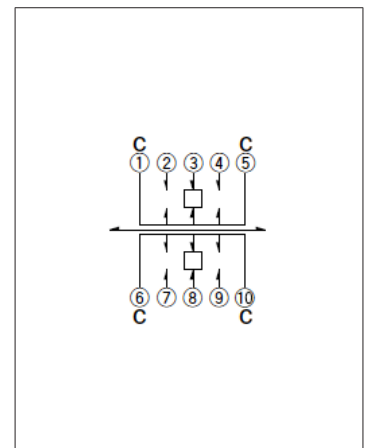

Viewed from direction A in the dimensions.

8.5 (H) mm, 3.0mm-travel
SSSU Series

Drawing No.9

■ Dimensions

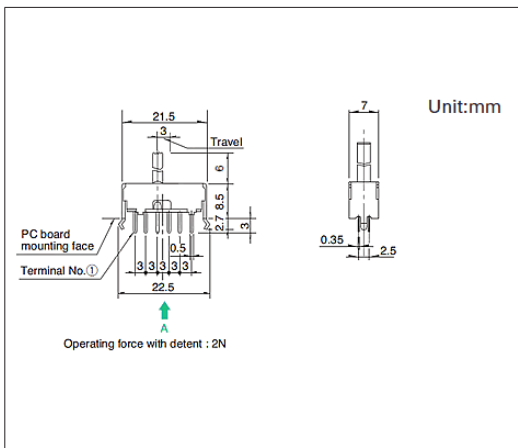

■ Mounting Hole Dimensions

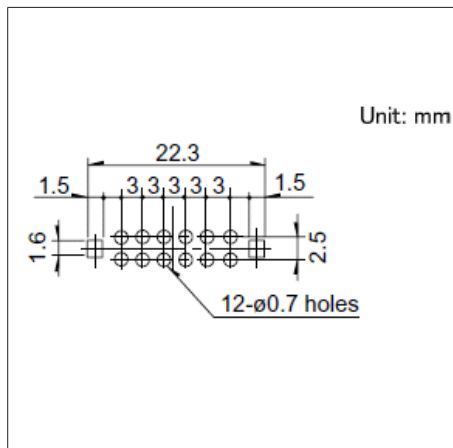

■ Circuit Diagram

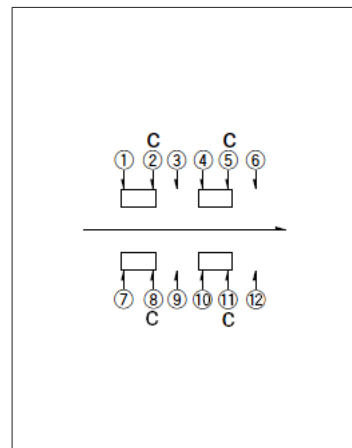

Viewed from direction A in the dimensions.

Drawing No.10

■ Dimensions

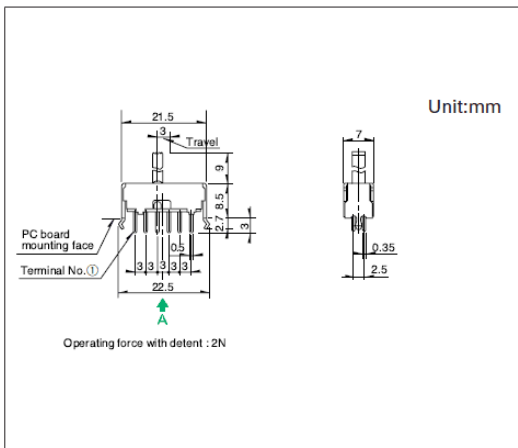

■ Mounting Hole Dimensions

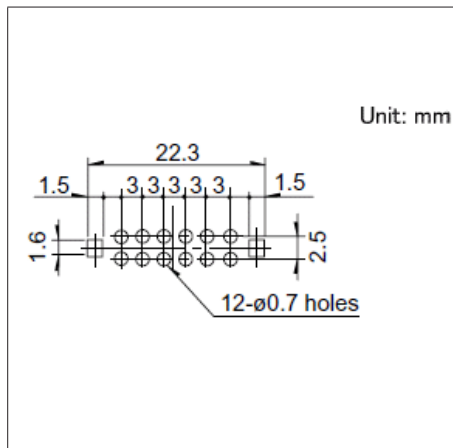

■ Circuit Diagram

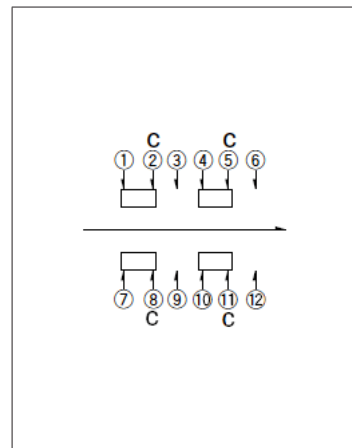

Viewed from direction A in the dimensions.

Drawing No.11

■ Dimensions

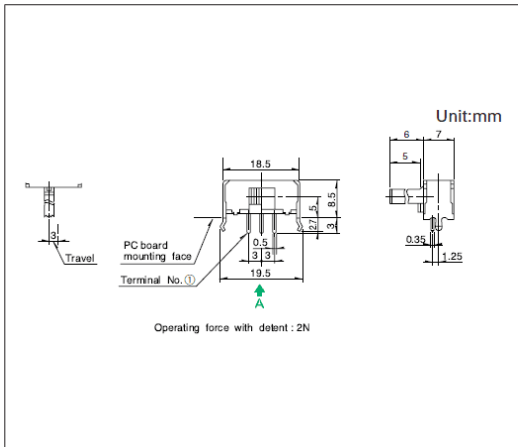

■ Mounting Hole Dimensions

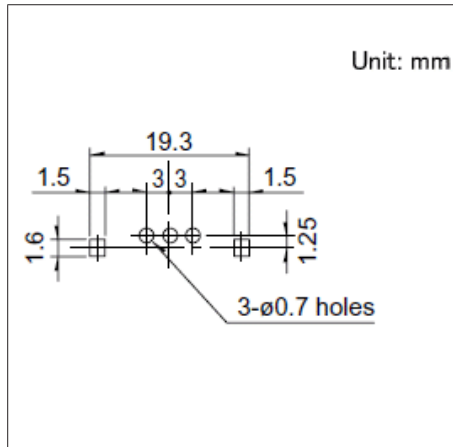

■ Circuit Diagram

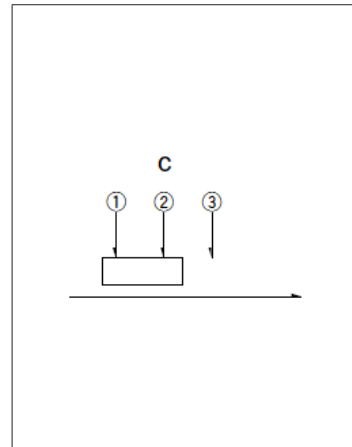

Viewed from direction A in the dimensions.

8.5 (H) mm, 3.0mm-travel
SSSU Series

Drawing No.12

■ Dimensions

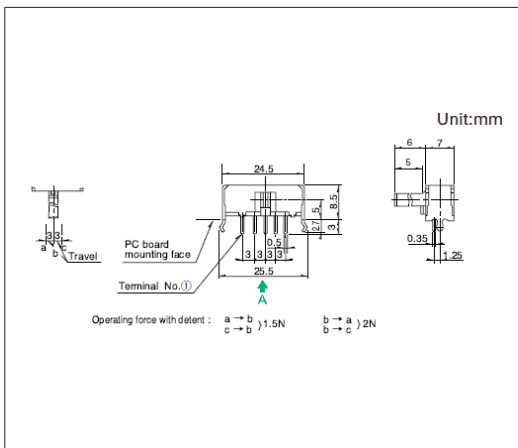

■ Mounting Hole Dimensions

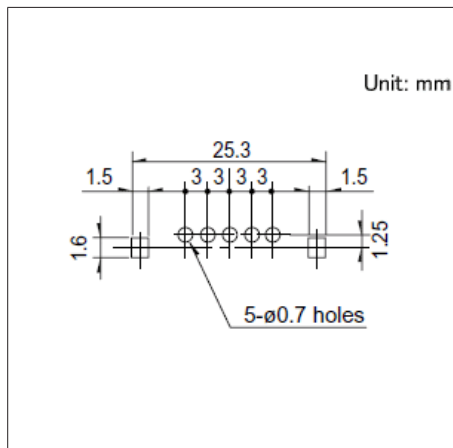

■ Circuit Diagram

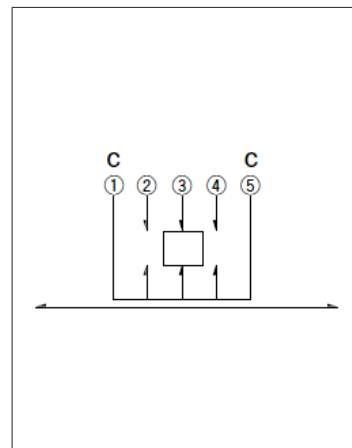

Viewed from direction A in the dimensions.

Drawing No.13

■ Dimensions

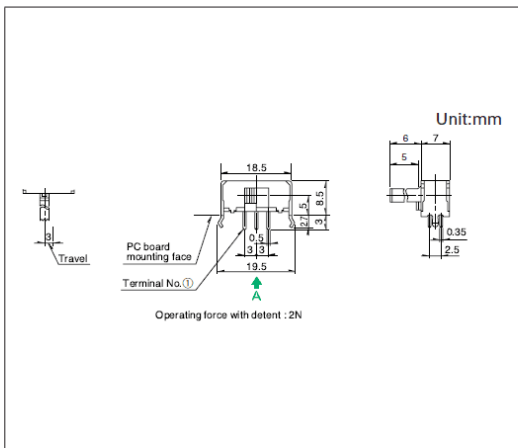

■ Mounting Hole Dimensions

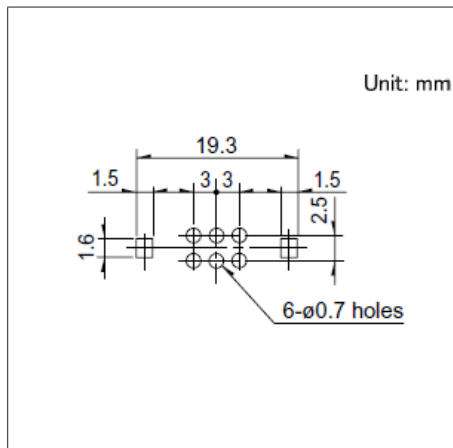

■ Circuit Diagram

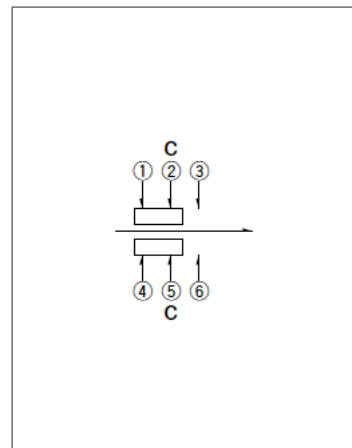

Viewed from direction A in the dimensions.

Drawing No.14

■ Dimensions

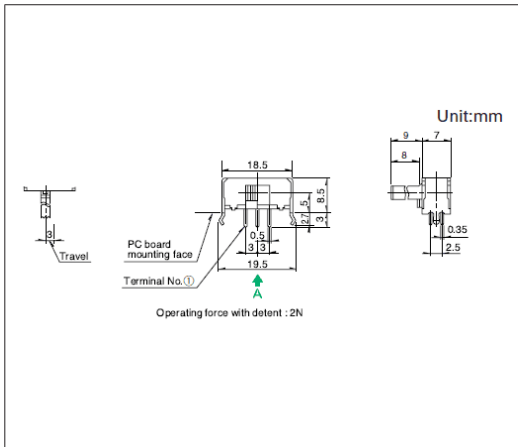

■ Mounting Hole Dimensions

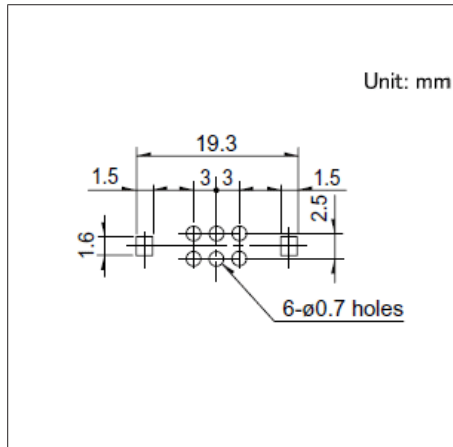

■ Circuit Diagram

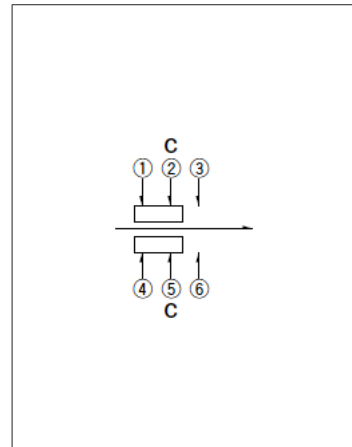

Viewed from direction A in the dimensions.

Drawing No.15

■ Dimensions

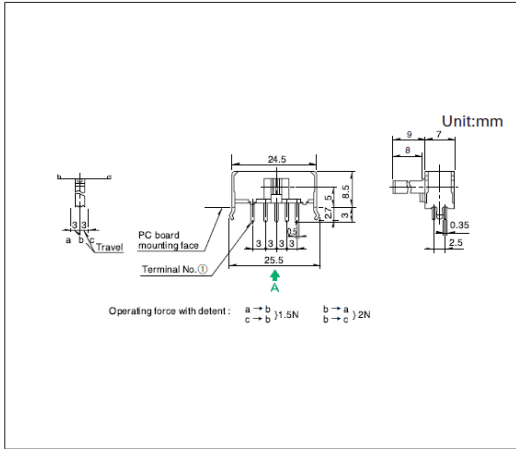

■ Mounting Hole Dimensions

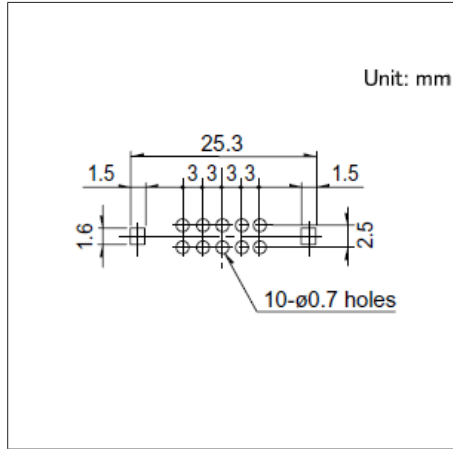

■ Circuit Diagram

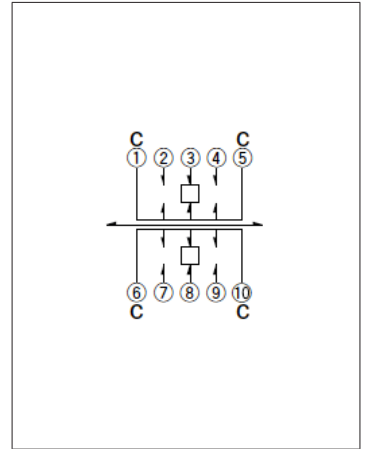

Viewed from direction A in the dimensions.

Slide Switches / Soldering Conditions

■ Example of Reflow Soldering Condition

1. Heating method: Double heating method with infrared heater.
2. Temperature measurement: Thermocouple $\phi 0.1$ to 0.2 CA (K) or CC (T) at soldering portion (copper foil surface).
A heat resisting tape should be used for fixed measurement.
3. Temperature profile

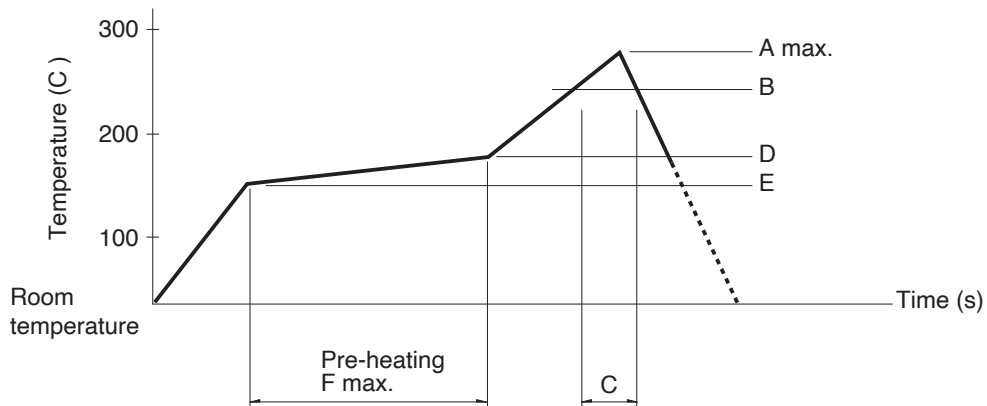

Series (Reflow type)		A (°C) 3s max.	B (°C)	C (s)	D (°C)	E (°C)	F (s)
SSSS2	Vertical 1-pole, 3-position	260	230	40	180	150	120
	Horizontal 1-pole, 2-position 1-pole, 3-position 2-pole, 3-position						
	Vertical 1-pole, 2-position	250					
SSAG, SSAJ, SSSS8, SSS7		260					

⚠ Note

1. The condition mentioned above is the temperature on the mounting surface of a PC board. There are cases where the PC board's temperature greatly differs from that of the switch, depending on the PC board's material, size, thickness, etc.
The above-stated conditions shall also apply to switch surface temperatures.
2. Soldering conditions differ depending on reflow soldering machines. Prior verification of soldering condition is highly recommended.

■ Reference for Hand Soldering

Series	Soldering temperature	Soldering time
SSSF, SSSU	350±10°C	3+1/0s
SSSS2	350±10°C	4s max.
SSSS9	350±10°C	3s max.
SSAG, SSAJ	350±5°C	3s max.
SSSS8	330±5°C	3s max.
SSSS7	320±5°C	3s max.

■ Reference for Dip Soldering

(For PC board terminal types)

Series	Items		Dip soldering	
	Preheating temperature	Preheating time	Soldering temperature	Duration of immersion
SSSS2	100°C max.	60s max.	260±5°C	3±1s
SSSS9	120°C max.	60s max.	260±5°C	5+0/-1s (2 times)
SSSF, SSSU	100°C max.	60s max.	260±5°C	10±1s/5±1s







Slide Switches / Cautions

1. Applying load to terminals during soldering under certain conditions may cause deformation and electrical property degradation.
2. Avoid use of water-soluble soldering flux, since it may corrode the switches.
3. Check and conform to soldering requirements under actual mass production conditions.
4. When soldering twice, wait until the first soldered portion cools to normal temperature. Continuous heating will deform the external portions, loosen or dislodge terminals, or may deteriorate their electrical characteristics.
5. Flux from around and above the PC board should not adhere to the switches.
6. After mounting the switches, if you intend to put the board into an oven in order to harden adhesive for other parts, please consult with us.
7. If you use a through-hole PC board or a PC board thinner or thicker than the recommendation, there may be greater heat stress. Verify the soldering conditions thoroughly before use.
8. Solder the switches with detent at the detent position. Soldering switches fixed at the center of the detent may deform the detent mechanisms.
9. No cleaning.
10. Protect small and thin switches from external forces in the set mounting process.
11. Tighten the mounting screws by applying the specified torque. Tightening with larger torque than the specified one will result in malfunction or breakage of screws.
12. Insert these switches to the specified mounting surface and mount them horizontally. If not mounted horizontally, these switches will malfunction.
13. The products are designed and manufactured for direct current resistance. Contact us for use of other resistances such as inductive (L) or capacitive (C).
14. The switch will break if you apply a greater stress than that specified. Take great care not to let the switch be subject to greater stress than specified.
15. Use of the switches in a dusty environment may lead to dusts entering through the openings and cause imperfect contact or malfunction. Take this into account for set design.
16. Corrosive gas if generated by peripheral parts of a set, malfunction such as imperfect contact may occur. Thorough investigation shall be required beforehand.
17. Storage
Store the products as delivered at normal temperature and humidity, out of direct sunlight and away from corrosive gases. Use them as soon as possible and no later than six months after delivery.
Once the seal is broken, use them as soon as possible.

Switches

Push Switches





List of Varieties

Series		SPPJ3	SPPJ2	SPUJ	SPUN	SPEJ	SPPH4	SPPH1	
Photo									
Dimensions (mm)		12.0×5.0×8.3 12.0×6.6×8.3	12.0×7.2×9.6 14.0×17.7×9.6	15.2×7.5×8.8	24.0×10.0×13.0	7.0×7.0×5.95	8.5×6.5×8.5	10.0×10.0×8.5	
Travel (mm)		2.5		2.0	2.5	—	2.2	1.5	
Total travel (mm)		3.5		3.0	3.5	1.7	3.0	2.5	
Poles		1 2	2	2 4		2			
Operating force		2.3 ±1N 3.3 ±1N	3 ±1.5N	1.5 ±1N 2.3 ±1N	2 ±1N 2.5 ±1N 3 ±1.5N 4 ±2N	3.5 ±0.7N	2 ±1N	2 (+1, -0.7)N 3 (+1, -0.7)N	
Operating temperature range		-40°C to +85°C		-10°C to +60°C		-40°C to +85°C	-10°C to +60°C		
Rating (max.)/(min.) (Resistive load)		0.2A 30V DC/50μA 3V DC		0.1A 30V DC/ 50μA 3V DC	0.1A 30V DC/ 50μA 3V DC 1A 25V DC/ -	0.2A 14V DC/ -	0.1A 30V DC/50μA 3V DC		
Electrical performance	Contact resistance (Initial performance/ After lifetime)	20mΩ max./40mΩ max.				150mΩ max./ 150mΩ max.	100mΩ max. (Initial performance)	20mΩ max./ 40mΩ max.	
	Insulation resistance	100MΩ min. 500V DC							
	Voltage proof	500V AC for 1 minute							
Mechanical performance	Terminal strength	5N for 1 minute				—	5N for 1 minute		
	Actuator strength	Operating direction	50N	30N	50N	49N	30N	50N	
		Pulling direction	—		50N	—	10N	—	
Durability	Operating life without load	10,000 cycles 40mΩ max.			10,000 cycles 40mΩ max. 30,000 cycles 40mΩ max.	10,000 cycles 150mΩ max.	10,000 cycles 100mΩ max.	10,000 cycles 40mΩ max.	
	Operating life with load (at max. rated load)	10,000 cycles 40mΩ max.			5,000 cycles 40mΩ max. 10,000 cycles 40mΩ max.	10,000 cycles 150mΩ max.	10,000 cycles 100mΩ max.	10,000 cycles 40mΩ max.	
Environmental performance	Cold	-40°C 96h	-20°C 96h			-40°C 500h	-20°C 96h		
	Dry heat	85°C 96h				85°C 500h	85°C 96h		
	Damp heat	40°C, 90 to 95%RH 96h				60°C, 90 to 95%RH 500h	40°C, 90 to 95%RH 96h		
Automotive		●	●	—	—	●	—	●	

⚠ Note

● Indicates applicability to all products in the series, while ○ indicates applicability to some products in the series.

Push Switches

Series		SPEF	SPED2	SPED3	SPED4
Photo					
Dimensions (mm)		9.4×9.0×6.9	16.8×14.0×9.5	18.0×14.0×7.4	18.0×14.0×7.27
Travel (mm)		1.5	—		
Total travel (mm)		2.7	4.5	3.8	
Poles		1	1 2	1	
Operating force		3 N 5 N	4.17 ±0.74N		
Operating temperature range		-40°C to +85°C		-40°C to +95°C	
Rating (max.)/(min.) (Resistive load)		1A 14.5V DC/ 50μA 3V DC	1A 14.5V DC/ -		2A 14.5V DC/ -
Electrical performance	Contact resistance (Initial performance/ After lifetime)	100mΩ max./ 1Ω max.	100mΩ max./100mΩ max.		
	Insulation resistance	3MΩ min. 100V DC	3MΩ min. 500V DC		
	Voltage proof	100V AC for 1 minute			
Mechanical performance	Terminal strength	—			
	Actuator strength	Operating direction	90N	98N	90N
		Pulling direction	30N	—	
Durability	Operating life without load	—			
	Operating life with load (at max. rated load)	30,000 cycles 100mΩ max.			
Environmental performance	Cold	-40°C 96h			
	Dry heat	85°C 96h	85°C 96h 105°C 192h	105°C 192h	
	Damp heat	40°C, 90 to 95%RH 96h			
Automotive		●	●	●	●

 Note

● Indicates applicability to all products in the series, while ○ indicates applicability to some products in the series.

2.5mm-travel Compact-sized Horizontal Type SPPJ3 Series

Compact type with a lever height of 4.7mm.

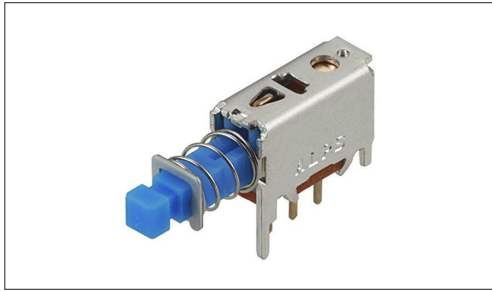

 Automotive

- Rating (max.)/(min.) (Resistive load): 0.2A 30V DC/50 μ A 3V DC
- Contact resistance (Initial performance/After lifetime):
20m Ω max./40m Ω max.
- Operating life without load: 10,000 cycles 40m Ω max.
- Operating life with load (at max. rated load): 10,000 cycles 40m Ω max.

Applications: Healthcare: Healthcare equipment
Automotive: Navigation/audio systems, HVAC

Product List

Products No.	Travel (mm)	Total travel (mm)	Poles	Operating force	Changeover timing	Mounting method	Operation	Terminal type	Dimensions (W×D×H) (mm)	Automotive	Drawing No.
SPPJ310500	2.5	3.5	1	2.3±1N	Non shorting	PC board	Latching	For PC board	12.0×5.0×8.3	●	1
SPPJ311500	2.5	3.5	1	2.3±1N	Non shorting	PC board	Momentary	For PC board	12.0×5.0×8.3	●	
SPPJ320600	2.5	3.5	2	3.3±1N	Non shorting	PC board	Latching	For PC board	12.0×6.6×8.3	●	2
SPPJ322300	2.5	3.5	2	3.3±1N	Non shorting	PC board	Momentary	For PC board	12.0×6.6×8.3	●	

Note

1. This catalog shows only outline specifications. When using the products, please obtain formal specifications for supply.
2. Please place purchase orders per minimum order unit (integer).
3. This products can be used in vehicles.
Although these products are designed to perform over a wide operating temperature range, please ensure that you receive and read the formal delivery specifications before use.
4. The SPPJ3 series should be operated in the direction of the arrow 2 as shown in the following figure and used within an angle of 15° in reference to the center. If an excessive force is applied from the direction of the arrow 1 against the lever, it might fall as illustrated, resulting in malfunction.

Packing Specifications

Bulk

Number of packages (pcs.)		Export package measurements (mm)
1 case / Japan	1 case / export packing	
900	4,500	400 x 270 x 290

2.5mm-travel Compact-sized Horizontal Type
SPPJ3 Series

Drawing No.1

■ Dimensions

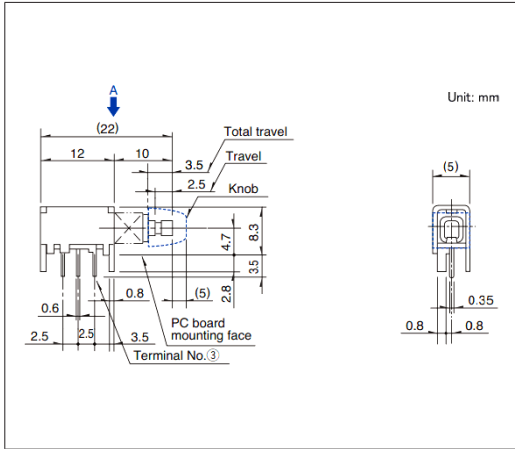

■ Mounting Hole Dimensions

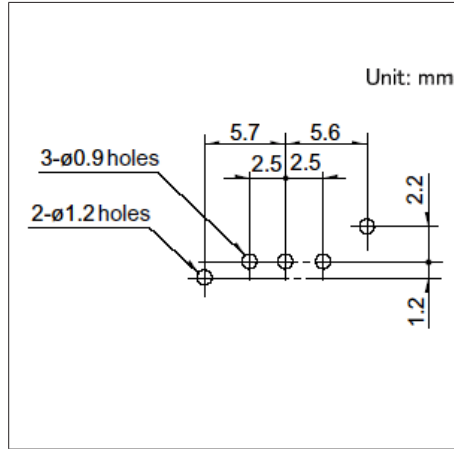

■ Circuit Diagram

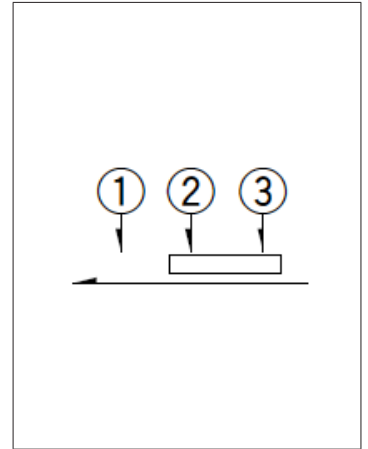

Viewed from direction A in the dimensions.

Drawing No.2

■ Dimensions

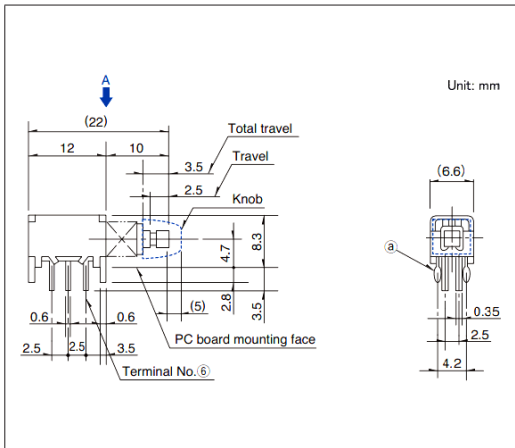

■ Mounting Hole Dimensions

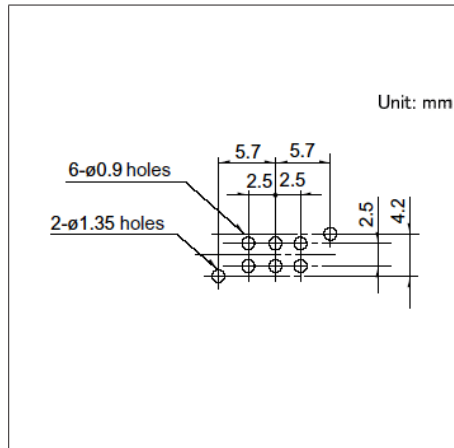

■ Circuit Diagram

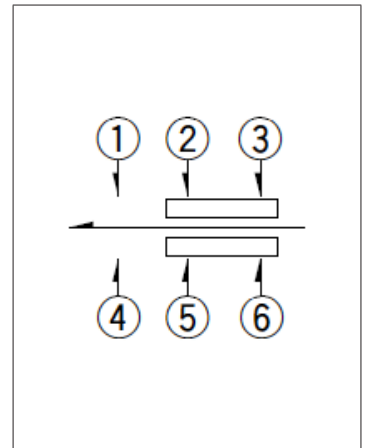

Viewed from direction A in the dimensions.

Switches

Push Switches

2.5mm-travel Horizontal Type
SPPJ2 Series

Lever height of 5.5mm, mountable directly on panels.

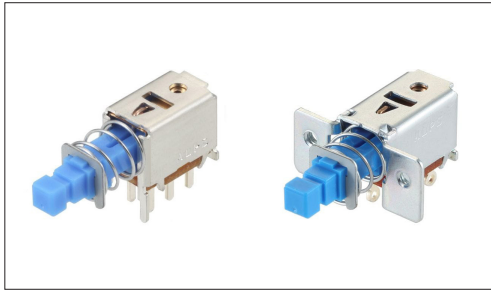

Automotive

- Rating (max.)/(min.) (Resistive load): 0.2A 30V DC/50 μ A 3V DC
- Contact resistance (Initial performance/After lifetime):
20m Ω max./40m Ω max.
- Operating life without load: 10,000 cycles 40m Ω max.
- Operating life with load (at max. rated load): 10,000 cycles 40m Ω max.

Applications: Automotive: Navigation/audio systems, HVAC

Product List

Products No.	Travel (mm)	Total travel (mm)	Poles	Operating force	Changeover timing	Mounting method	Operation	Terminal type	Dimensions (W×D×H) (mm)	Automotive	Drawing No.
SPPJ222200	2.5	3.5	2	3 \pm 1.5N	Non shorting	PC board	Latching	For PC board	12.0×7.2×9.6	●	1
SPPJ223200	2.5	3.5	2	3 \pm 1.5N	Non shorting	PC board	Momentary	For PC board	12.0×7.2×9.6	●	
SPPJ225800	2.5	3.5	2	3 \pm 1.5N	Non shorting	M2-screw	Latching	Lead	14.0×17.7×9.6	●	2
SPPJ226400	2.5	3.5	2	3 \pm 1.5N	Non shorting	M2-screw	Momentary	Lead	14.0×17.7×9.6	●	

Note

- This catalog shows only outline specifications. When using the products, please obtain formal specifications for supply.
- Please place purchase orders per minimum order unit (integer).
- This products can be used in vehicles.
Although these products are designed to perform over a wide operating temperature range, please ensure that you receive and read the formal delivery specifications before use.

Packing Specifications

Bulk

Products No.	Number of packages(pcs.)		Export package measurements (mm)
	1 case / Japan	1 case / export packing	
SPPJ222200 SPPJ223200	700	3,500	400 x 270 x 290
SPPJ225800 SPPJ226400	500	2,500	400 x 270 x 290

Drawing No.1

Dimensions

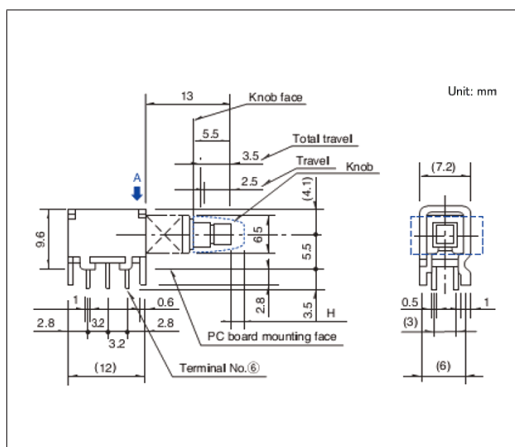

Mounting Hole Dimensions

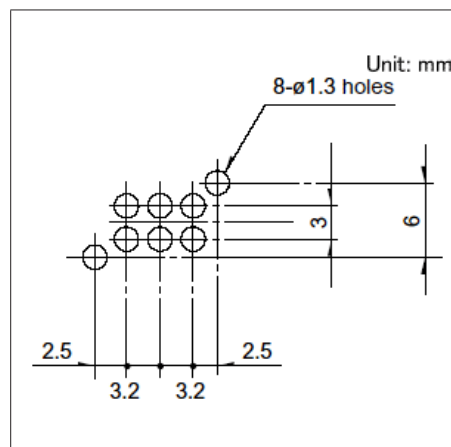

Circuit Diagram

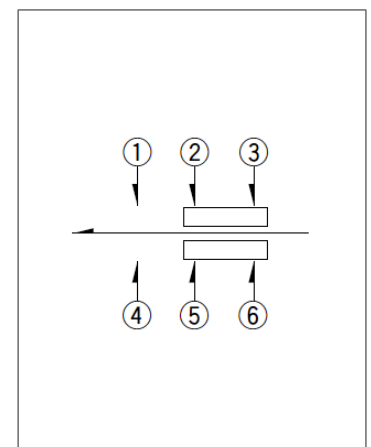

Viewed from direction A in the dimensions.

2.5mm-travel Horizontal Type
SPPJ2 Series

Drawing No.2

■ Dimensions

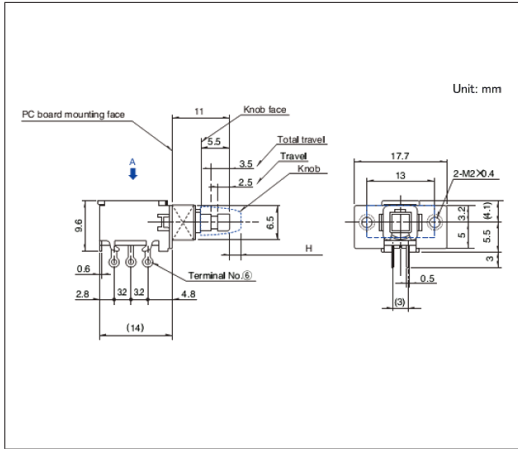

■ Circuit Diagram

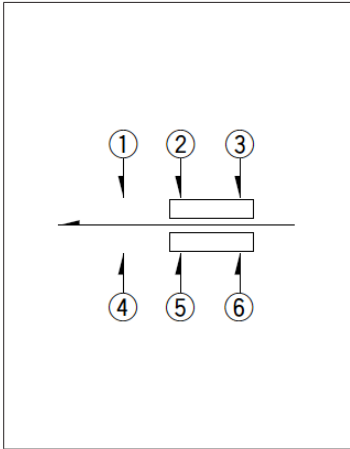

2.0mm-travel Horizontal Type SPUJ Series

Lever height of 5.0mm, supporting multi-circuit configurations.

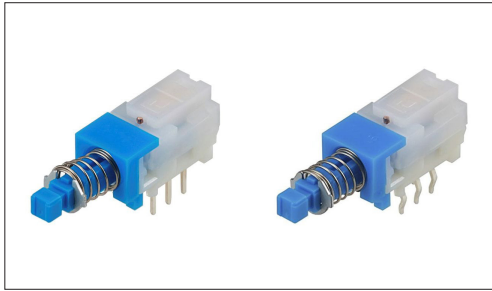

- Rating (max.)/(min.) (Resistive load): 0.1 A 30V DC/50 μ A 3V DC
- Contact resistance (Initial performance/After lifetime):
20m Ω max./40m Ω max.
- Operating life without load: 10,000 cycles 40m Ω max.
- Operating life with load (at max. rated load): 10,000 cycles 40m Ω max.

Applications: Audio_TV:Audio

Product List

Products No.	Travel (mm)	Total travel (mm)	Poles	Operating force	Changeover timing	Mounting method	Operation	Terminal type	Dimensions (W×D×H) (mm)	Automotive	Drawing No.
SPUJ190900	2.0	3.0	2	1.5±1N	Non shorting	PC board	Latching	Straight	15.2×7.5×8.8	—	1
SPUJ191000	2.0	3.0	2	1.5±1N	Non shorting	PC board	Latching	Snap-in	15.2×7.5×8.8	—	2
SPUJ191500	2.0	3.0	2	1.5±1N	Non shorting	PC board	Momentary	Straight	15.2×7.5×8.8	—	1
SPUJ191900	2.0	3.0	2	1.5±1N	Non shorting	PC board	Momentary	Snap-in	15.2×7.5×8.8	—	2
SPUJ193700	2.0	3.0	4	2.3±1N	Non shorting	PC board	Latching	Straight	15.2×7.5×8.8	—	3
SPUJ193900	2.0	3.0	4	2.3±1N	Non shorting	PC board	Latching	Snap-in	15.2×7.5×8.8	—	4
SPUJ194500	2.0	3.0	4	2.3±1N	Non shorting	PC board	Momentary	Straight	15.2×7.5×8.8	—	3

Note

1. This catalog shows only outline specifications. When using the products, please obtain formal specifications for supply.
2. Please place purchase orders per minimum order unit (integer).

Packing Specifications

Bulk

Products No.	Number of packages (pcs.)		Export package measurements (mm)
	1 case / Japan	1 case / export packing	
SPUJ190900 SPUJ191000 SPUJ191500 SPUJ191900	600	3,000	400 x 270 x 290
SPUJ193700 SPUJ193900 SPUJ194500	400	2,000	400 x 270 x 290

2.0mm-travel Horizontal Type
SPUJ Series

Drawing No.1

■ Dimensions

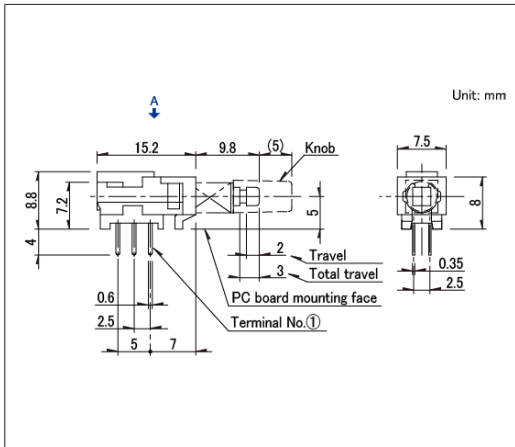

■ Mounting Hole Dimensions

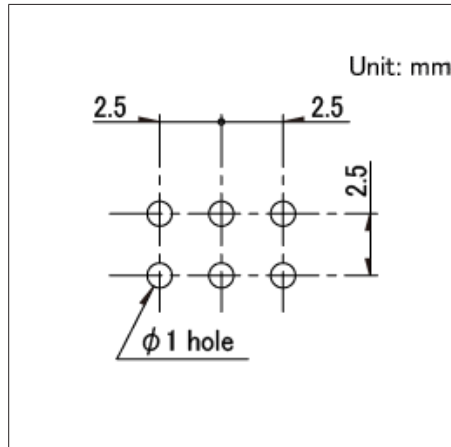

■ Circuit Diagram

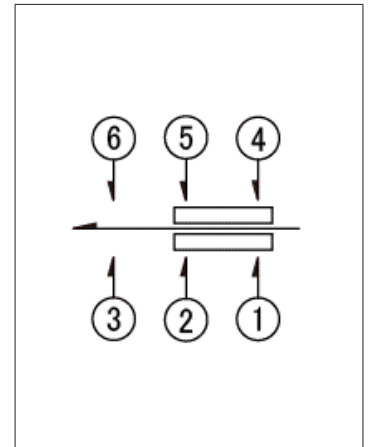

Viewed from direction A in the dimensions.

Drawing No.2

■ Dimensions

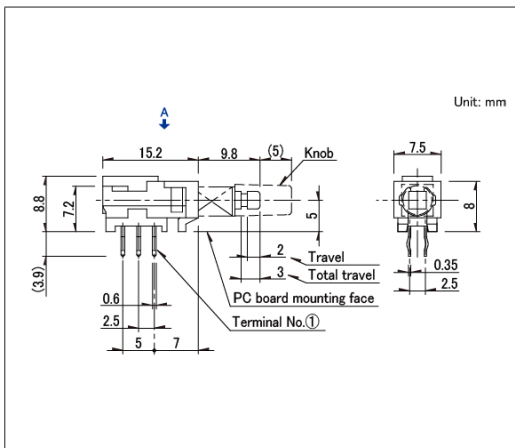

■ Mounting Hole Dimensions

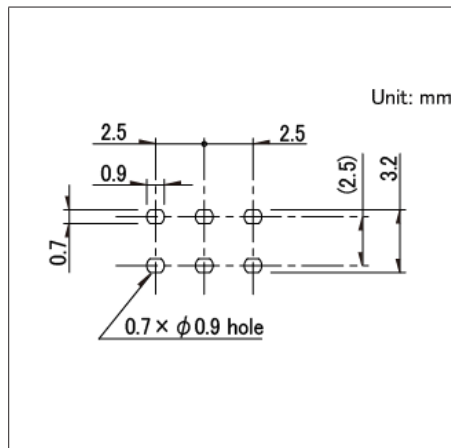

■ Circuit Diagram

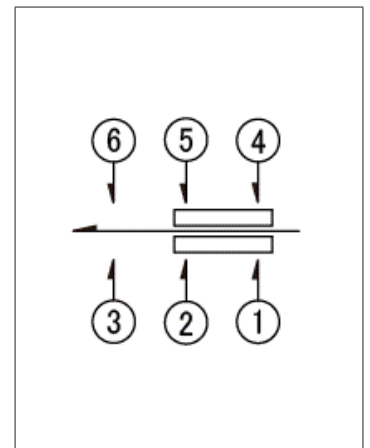

Viewed from direction A in the dimensions.

Drawing No.3

■ Dimensions

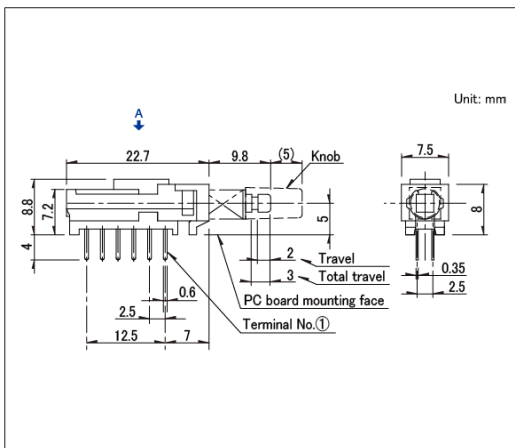

■ Mounting Hole Dimensions

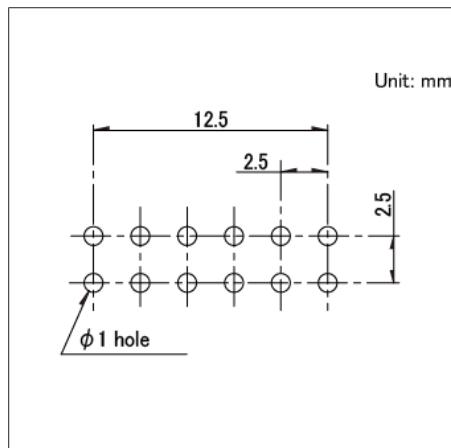

■ Circuit Diagram

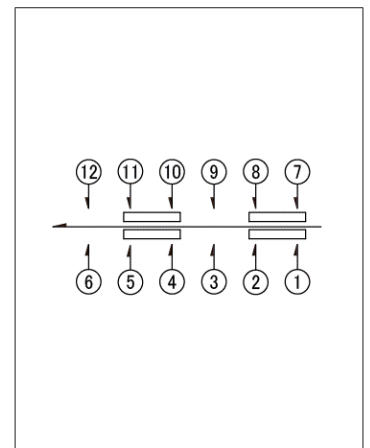

Viewed from direction A in the dimensions.

2.0mm-travel Horizontal Type
SPUJ Series

Drawing No.4

■ Dimensions

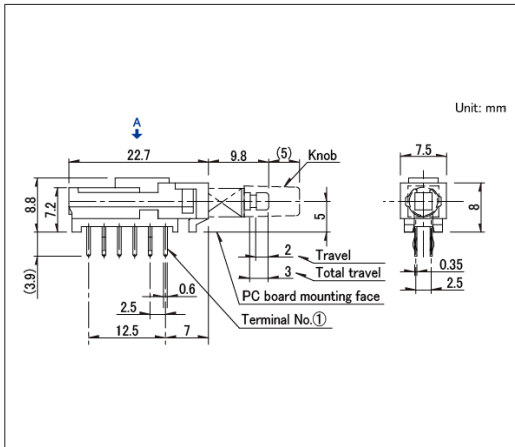

■ Mounting Hole Dimensions

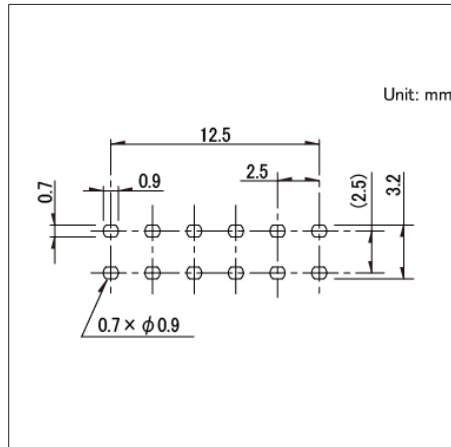

■ Circuit Diagram

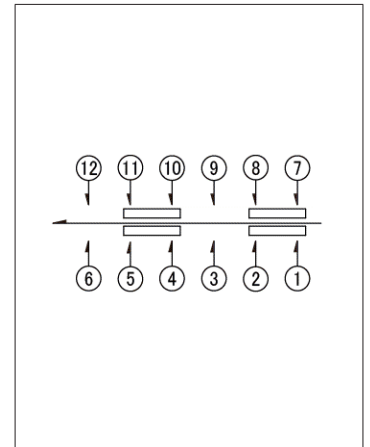

Viewed from direction A in the dimensions.

Switches

Push Switches

2.5mm-travel Large-sized Horizontal Type
SPUN Series

Includes multi-circuit and medium-current options in the lineup.

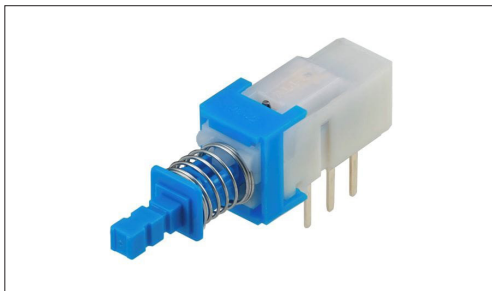

- Rating (max.)/(min.) (Resistive load): 0.1 A 30V DC/50 μ A 3V DC (Standard)
1 A 25V DC/ - (Medium-current)
- Contact resistance (Initial performance/After lifetime):
20m Ω max./40m Ω max.
- Operating life without load: 30,000 cycles 40m Ω max. (Standard)
10,000 cycles 40m Ω max. (Medium-current)
- Operating life with load (at max. rated load):
10,000 cycles 40m Ω max. (Standard)
5,000 cycles 40m Ω max. (Medium-current)

Applications: Audio_TV: Audio

■ Product List

Products No.	Travel (mm)	Total travel (mm)	Rating	Poles	Operating force	Changeover timing	Mounting method	Operation	Terminal type	Dimensions (W×D×H) (mm)	Automotive	Drawing No.
SPUN191400	2.5	3.5	Standard	2	2 \pm 1N	Non shorting	PC board	Latching	Straight	24.0×10.0×13.0	—	1
SPUN191600	2.5	3.5	Standard	2	2 \pm 1N	Non shorting	PC board	Latching	Snap-in	24.0×10.0×13.0	—	2
SPUN190900	2.5	3.5	Standard	2	2 \pm 1N	Non shorting	PC board	Momentary	Straight	24.0×10.0×13.0	—	1
SPUN191000	2.5	3.5	Standard	2	2 \pm 1N	Non shorting	PC board	Momentary	Snap-in	24.0×10.0×13.0	—	2
SPUN194700	2.5	3.5	Standard	4	2.5 \pm 1N	Non shorting	PC board	Latching	Straight	24.0×10.0×13.0	—	3
SPUN194900	2.5	3.5	Standard	4	2.5 \pm 1N	Non shorting	PC board	Latching	Snap-in	24.0×10.0×13.0	—	4
SPUN192600	2.5	3.5	Medium-current	2	3 \pm 1.5N	Non shorting	PC board	Latching	Straight	24.0×10.0×13.0	—	5
SPUN192800	2.5	3.5	Medium-current	2	3 \pm 1.5N	Non shorting	PC board	Latching	Snap-in	24.0×10.0×13.0	—	2
SPUN19C400	2.5	3.5	Medium-current	4	4 \pm 2N	Non shorting	PC board	Latching	Snap-in	24.0×10.0×13.0	—	4

⚠ Note

1. This catalog shows only outline specifications. When using the products, please obtain formal specifications for supply.
2. Please place purchase orders per minimum order unit (integer).

■ Packing Specifications

Bulk

Products No.	Number of packages (pcs.)		Export package measurements (mm)
	1 case / Japan	1 case / export packing	
SPUN191400 SPUN191600 SPUN190900 SPUN191000 SPUN192600 SPUN192800	250	1,250	400 x 270 x 290
SPUN194700 SPUN194900 SPUN19C400	140	700	400 x 270 x 290

2.5mm-travel Large-sized Horizontal Type
SPUN Series

Drawing No.1

■ Dimensions

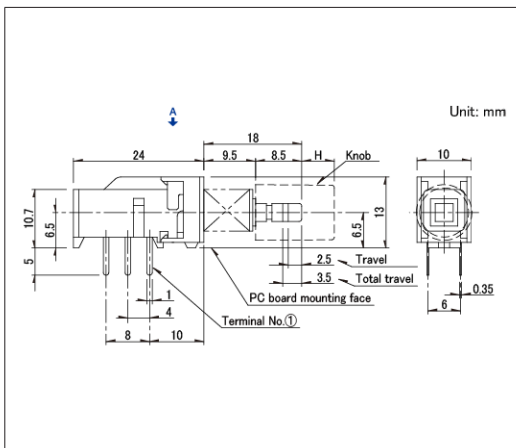

■ Mounting Hole Dimensions

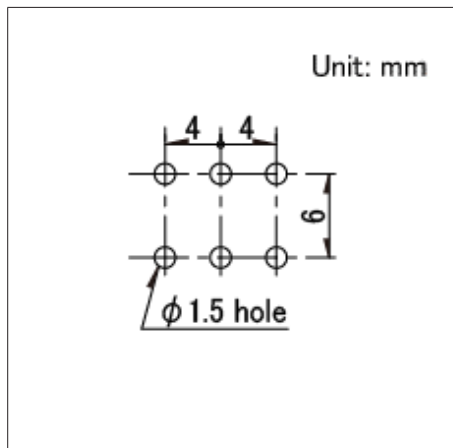

■ Circuit Diagram

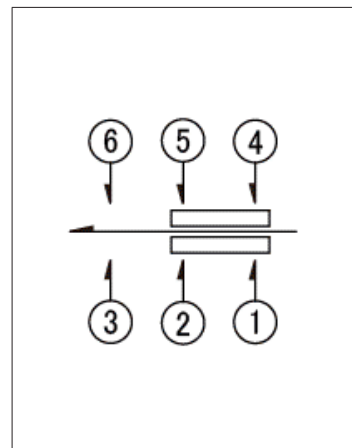

Viewed from direction A in the dimensions.

Drawing No.2

■ Dimensions

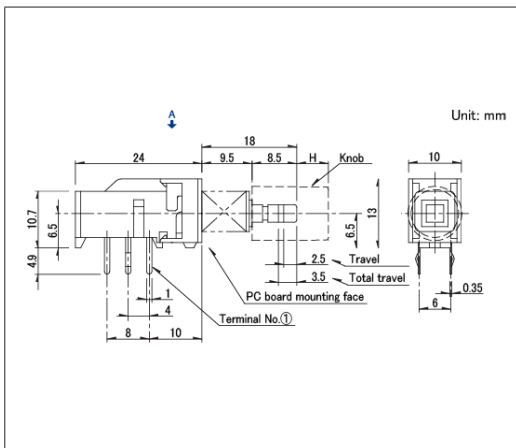

■ Mounting Hole Dimensions

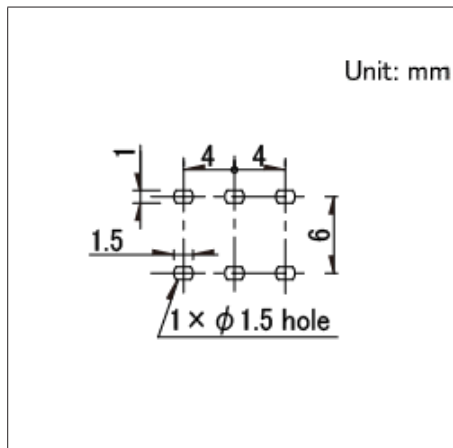

■ Circuit Diagram

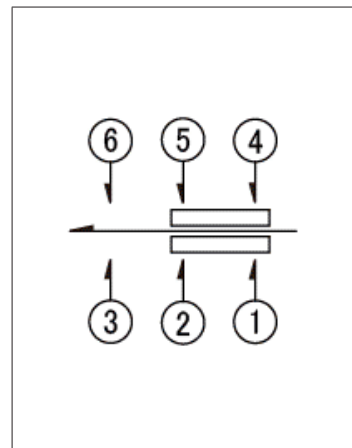

Viewed from direction A in the dimensions.

Drawing No.3

■ Dimensions

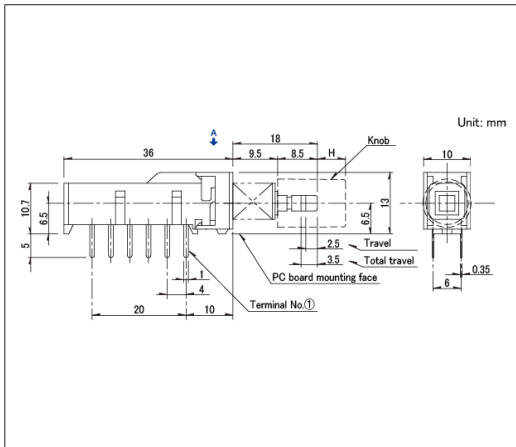

■ Mounting Hole Dimensions

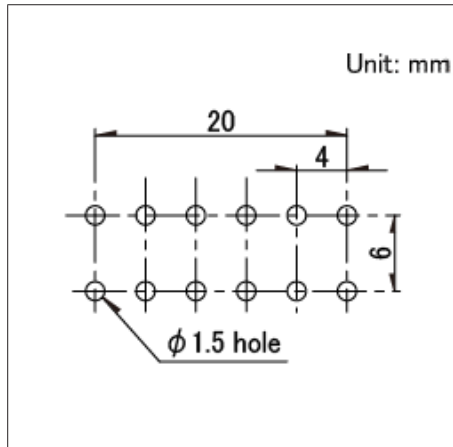

■ Circuit Diagram

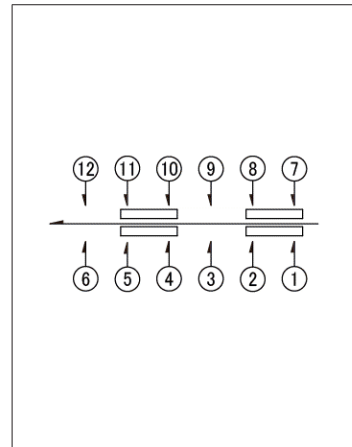

Viewed from direction A in the dimensions.

2.5mm-travel Large-sized Horizontal Type
SPUN Series

Drawing No.4

■ Dimensions

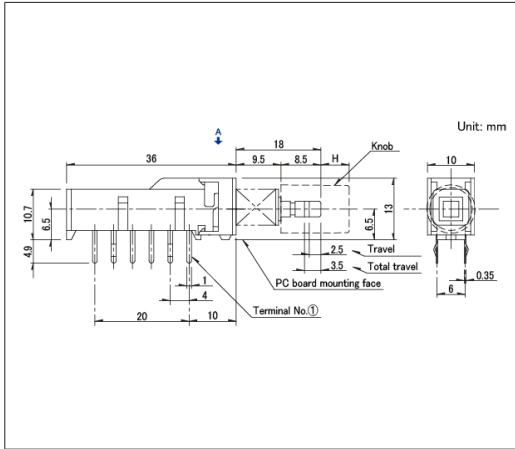

■ Mounting Hole Dimensions

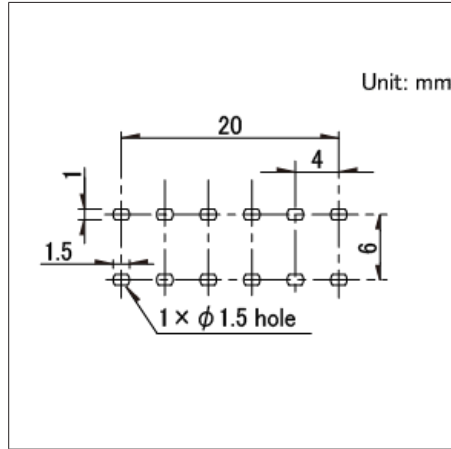

■ Circuit Diagram

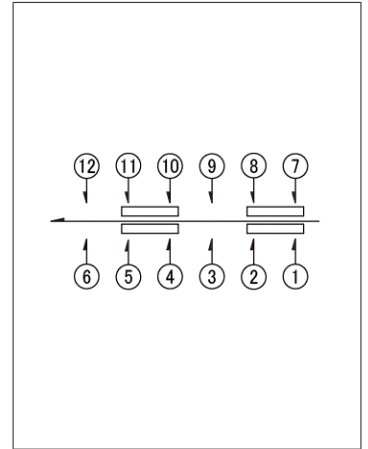

Viewed from direction A in the dimensions.

Drawing No.5

■ Dimensions

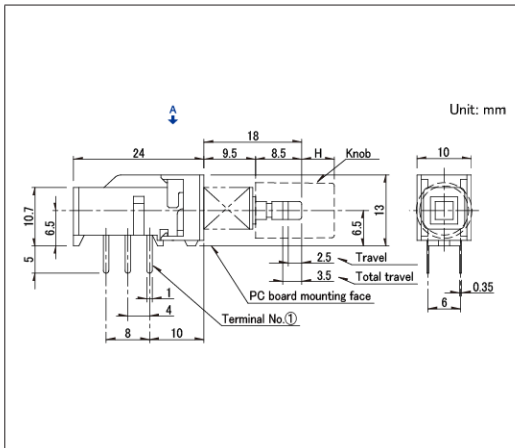

■ Mounting Hole Dimensions

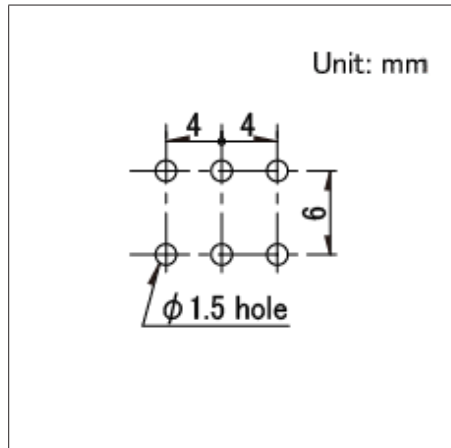

■ Circuit Diagram

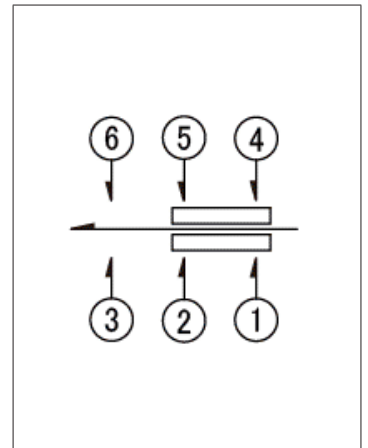

Viewed from direction A in the dimensions.

Switches

Push Switches

Compact Momentary Type
SPEJ Series

Dual-circuit, dual-contact momentary action with a satisfying click feel.

 Automotive

- Rating (max.)/(min.) (Resistive load): 0.2A 14V DC / -
- Contact resistance (Initial performance/After lifetime):
150mΩ max./150mΩ max.
- Operating life without load: 10,000 cycles 150mΩ max.
- Operating life with load (at max. rated load): 10,000 cycles 150mΩ max.

Applications: Automotive: Side Mirror, Power Windows

■ Product List

Products No.	Total travel (mm)	Poles	Positions	Operating force	Dimensions (W×D×H) (mm)	Automotive	Drawing No.
SPEJ110100	1.7	2	2	3.5±0.7N	7.0×7.0×5.95	●	1

 Note

1. This catalog shows only outline specifications. When using the products, please obtain formal specifications for supply.
2. Please place purchase orders for taping products per minimum order unit (1 reel or a case).

■ Packing Specifications

Taping

Number of packages (pcs.)			Tape width (mm)	Export package measurements (mm)
1 reel	1 case / Japan	1 case / export packing		
500	1,000	2,000	24	404 x 397 x 140

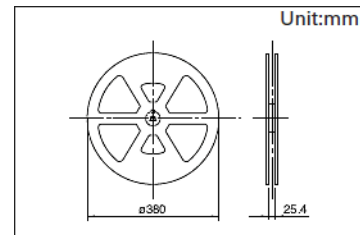

Drawing No. 1

■ Dimensions

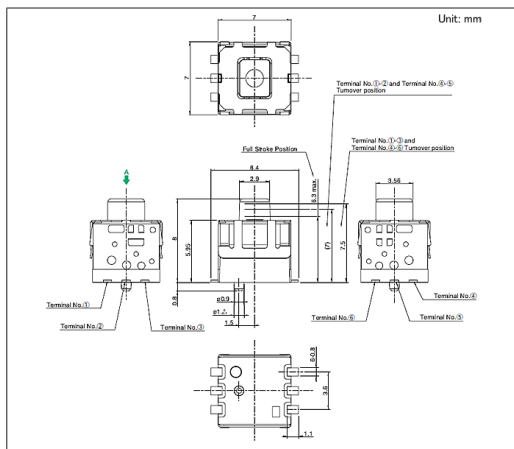

■ Recommend Pattern

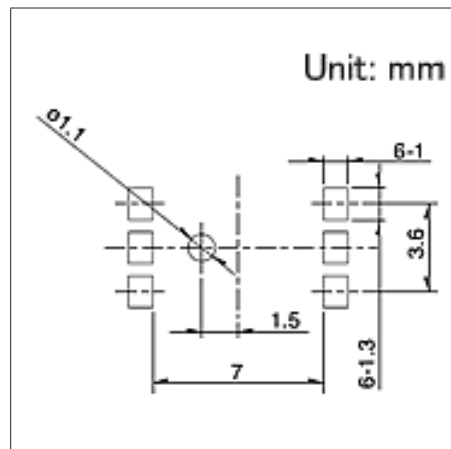

■ Circuit Diagram

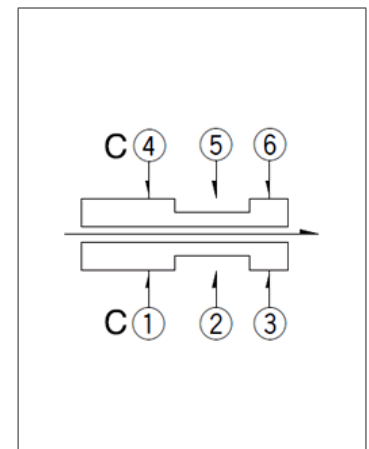

Switches Push Switches

2.2mm-travel Medium-sized Vertical Type
SPPH4 Series

Medium-sized design prioritizing ease of use.

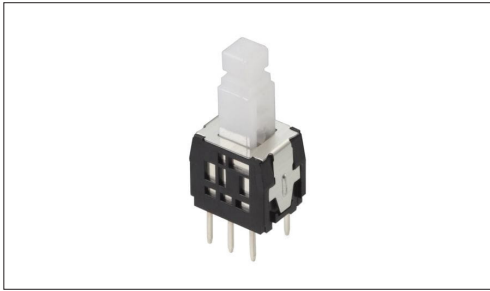

- Rating (max.)/(min.) (Resistive load): 0.1 A 30V DC/50μA 3V DC
- Contact resistance (Initial performance/After lifetime):
100mΩ max. (Initial performance)
- Operating life without load: 10,000 cycles 100mΩ max.
- Operating life with load (at max. rated load): 10,000 cycles 100mΩ max.

Applications: Audio_TV: Visual, Audio, Pro audio

■ Product List

Products No.	Travel (mm)	Total travel (mm)	Poles	Operating force	Changeover timing	Mounting method	Operation	Terminal type	Location lug	Dimensions (W×D×H) (mm)	Automotive	Drawing No.
SPPH410100	2.2	3.0	2	2±1N	Non shorting	PC board	Latching	Straight	With	8,5×6,5×8,5	—	1
SPPH410200	2.2	3.0	2	2±1N	Non shorting	PC board	Momentary	Straight	With	8,5×6,5×8,5	—	
SPPH420100	2.2	3.0	2	2±1N	Non shorting	PC board	Latching	Straight	Without	8,5×6,5×8,5	—	2
SPPH430100	2.2	3.0	2	2±1N	Non shorting	PC board	Latching	Snap-in	With	8,5×6,5×8,5	—	3
SPPH430200	2.2	3.0	2	2±1N	Non shorting	PC board	Momentary	Snap-in	With	8,5×6,5×8,5	—	

Note

1. This catalog shows only outline specifications. When using the products, please obtain formal specifications for supply.
2. Please place purchase orders per minimum order unit (integer).

■ Packing Specifications

Bulk

Number of packages (pcs.)		Export package measurements (mm)
1 case / Japan	1 case / export packing	
1,200	6,000	400 x 270 x 290

Drawing No. 1

■ Dimensions

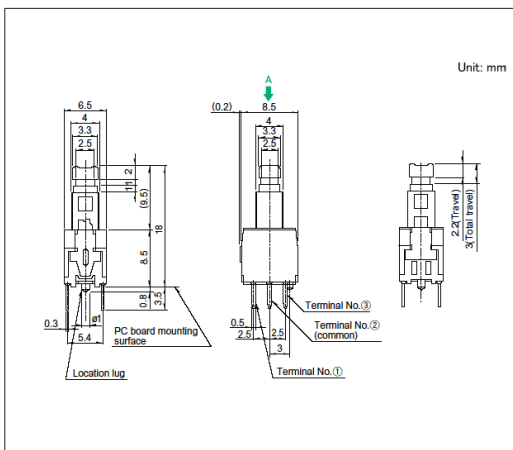

■ Mounting Hole Dimensions

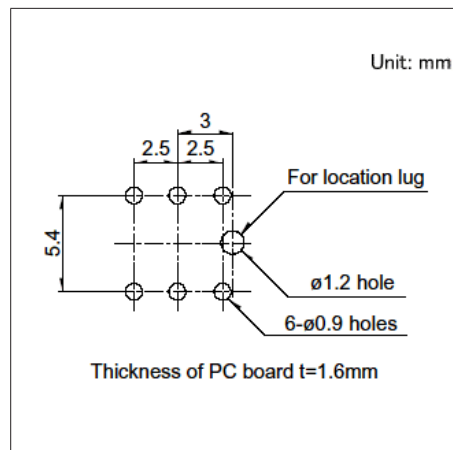

■ Circuit Diagram

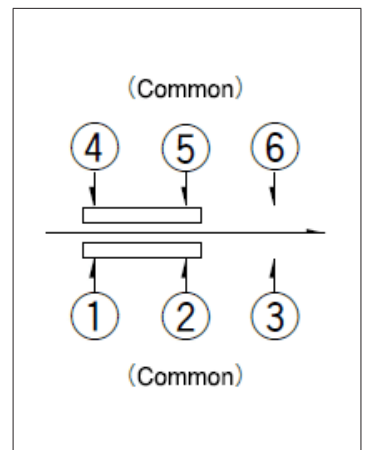

Viewed from direction A in the dimensions.

2.2mm-travel Medium-sized Vertical Type
SPPH4 Series

Drawing No.2

■ Dimensions

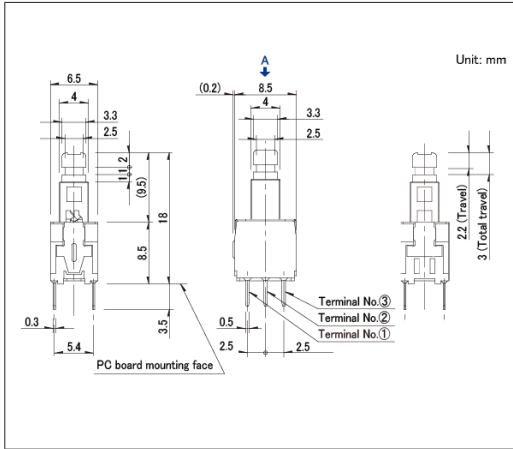

■ Mounting Hole Dimensions

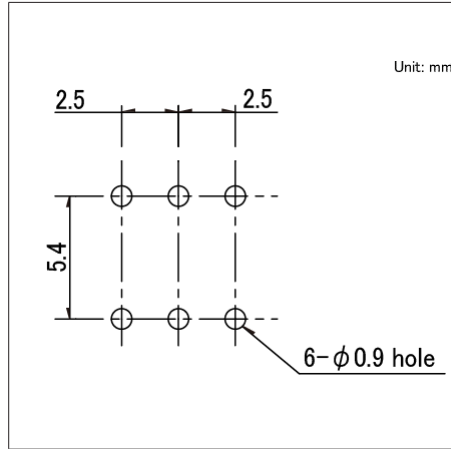

■ Circuit Diagram

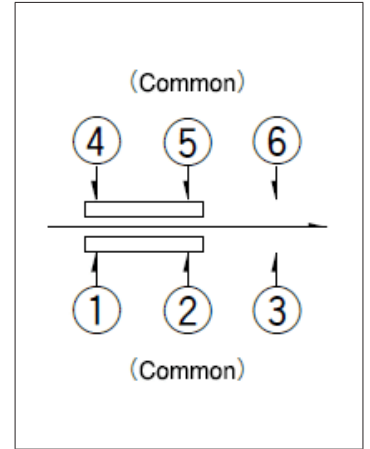

Viewed from direction A in the dimensions.

Drawing No.3

■ Dimensions

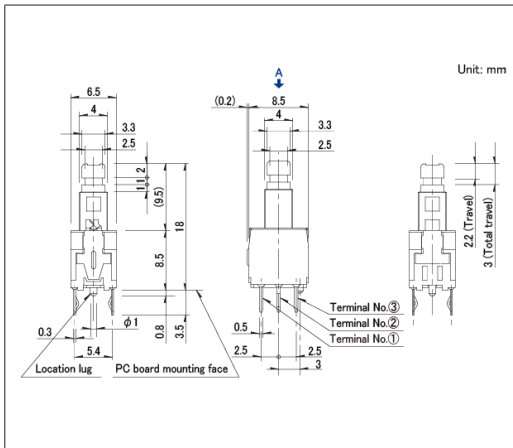

■ Mounting Hole Dimensions

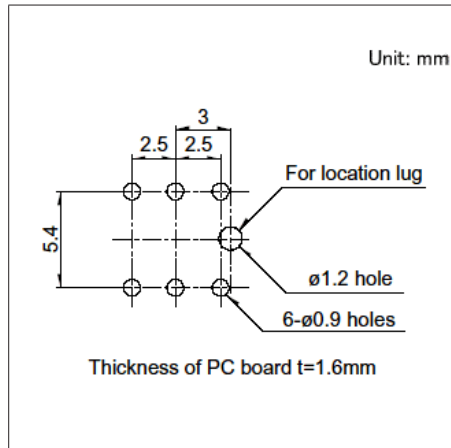

■ Circuit Diagram

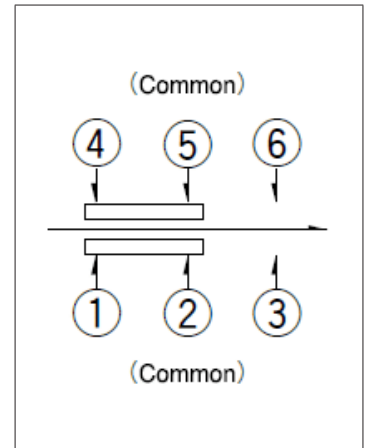

Viewed from direction A in the dimensions.

Switches

Push Switches

1.5mm-travel Vertical Type
SPPH1 Series

Offers a lineup of two types of knob shapes.

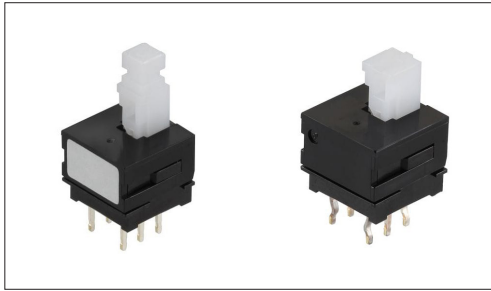
 Automotive

- Rating (max.)/(min.) (Resistive load): 0.1 A 30V DC/50 μ A 3V DC
- Contact resistance (Initial performance/After lifetime):
20m Ω max./40m Ω max.
- Operating life without load: 10,000 cycles 40m Ω max.
- Operating life with load (at max. rated load): 10,000 cycles 40m Ω max.

Applications: Audio_TV: Visual, Audio, Pro audio
Automotive: Navigation/audio systems, HVAC

■ Product List

Products No.	Travel (mm)	Total travel (mm)	Poles	Operating force	Changeover timing	Mounting method	Operation	Terminal type	Dimensions (W×D×H) (mm)	Automotive	Drawing No.
SPPH110800	1.5	2.5	2	2 (+1, -0.7) N	Non shorting	PC board	Latching	Straight	10.0×10.0×8.5	●	1
SPPH110300	1.5	2.5	2	2 (+1, -0.7) N	Non shorting	PC board	Momentary	Straight	10.0×10.0×8.5	●	2
SPPH120400	1.5	2.5	2	2 (+1, -0.7) N	Non shorting	PC board	Latching	Straight	10.0×10.0×8.5	●	3
SPPH120100	1.5	2.5	2	2 (+1, -0.7) N	Non shorting	PC board	Momentary	Straight	10.0×10.0×8.5	●	4
SPPH130400	1.5	2.5	2	2 (+1, -0.7) N	Non shorting	PC board	Latching	Snap-in	10.0×10.0×8.5	●	5
SPPH130100	1.5	2.5	2	2 (+1, -0.7) N	Non shorting	PC board	Momentary	Snap-in	10.0×10.0×8.5	●	6
SPPH140300	1.5	2.5	2	2 (+1, -0.7) N	Non shorting	PC board	Latching	Snap-in	10.0×10.0×8.5	●	7
SPPH140100	1.5	2.5	2	2 (+1, -0.7) N	Non shorting	PC board	Momentary	Snap-in	10.0×10.0×8.5	●	8
SPPH110900	1.5	2.5	2	3 (+1, -0.7) N	Non shorting	PC board	Latching	Straight	10.0×10.0×8.5	●	9
SPPH130500	1.5	2.5	2	3 (+1, -0.7) N	Non shorting	PC board	Latching	Snap-in	10.0×10.0×8.5	●	10
SPPH140400	1.5	2.5	2	3 (+1, -0.7) N	Non shorting	PC board	Latching	Snap-in	10.0×10.0×8.5	●	11

 Note

1. This catalog shows only outline specifications. When using the products, please obtain formal specifications for supply.
2. Please place purchase orders per minimum order unit (integer).
3. This products can be used in vehicles.

Although these products are designed to perform over a wide operating temperature range, please ensure that you receive and read the formal delivery specifications before use.

■ Packing Specifications

Bulk

Number of packages (pcs.)		Export package measurements (mm)
1 case / Japan	1 case / export packing	
800	4,000	400 x 270 x 290

1.5mm-travel Vertical Type
SPPH1 Series

Drawing No.1

■ Dimensions

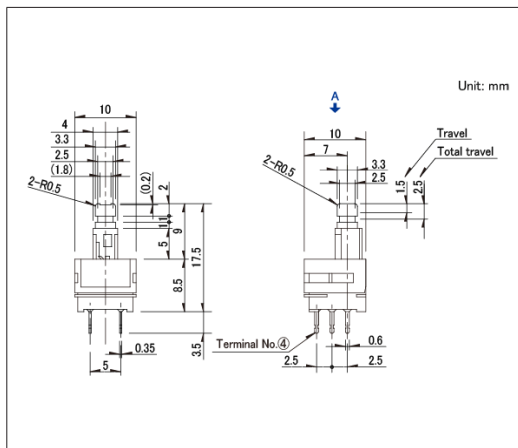

■ Mounting Hole Dimensions

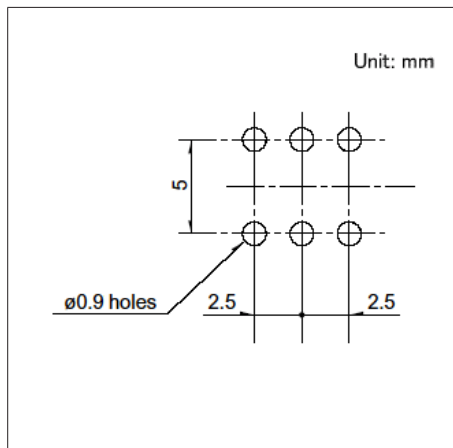

■ Circuit Diagram

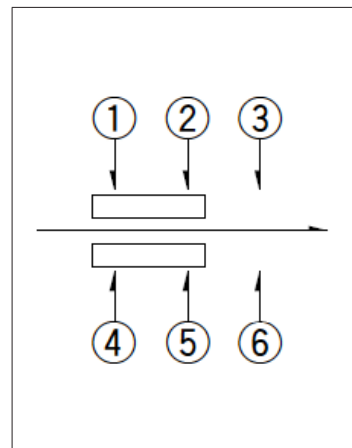

Viewed from direction A in the dimensions.

Drawing No.2

■ Dimensions

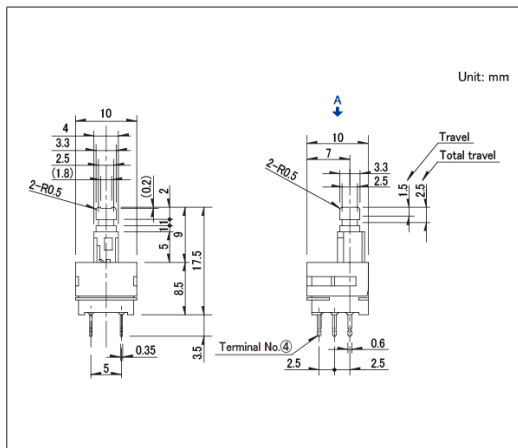

■ Mounting Hole Dimensions

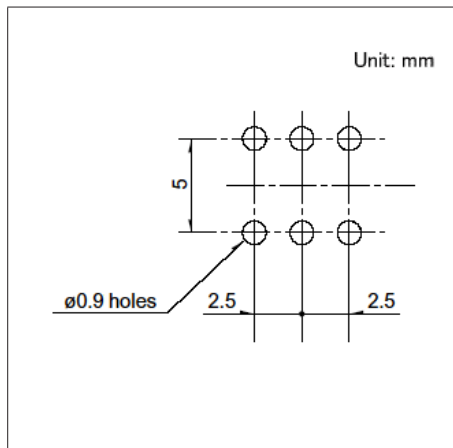

■ Circuit Diagram

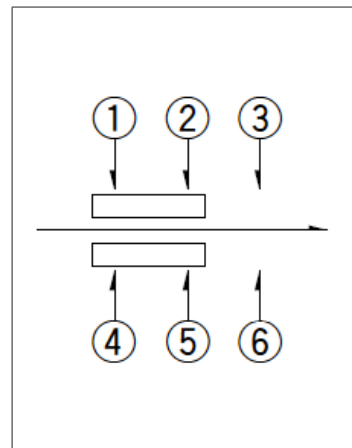

Viewed from direction A in the dimensions.

Drawing No.3

■ Dimensions

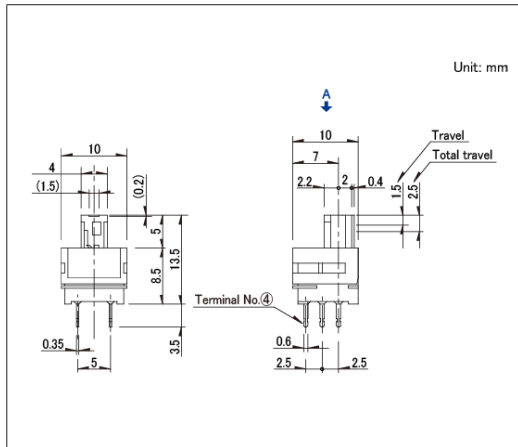

■ Mounting Hole Dimensions

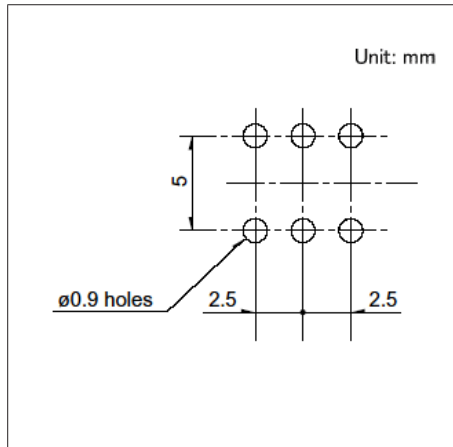

■ Circuit Diagram

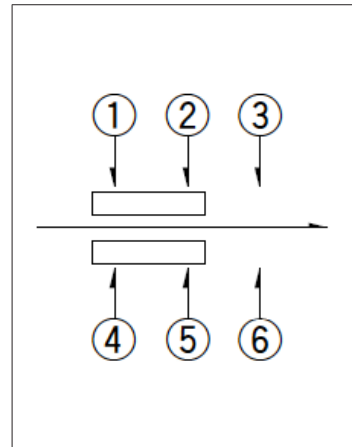

Viewed from direction A in the dimensions.

1.5mm-travel Vertical Type
SPPH1 Series

Drawing No.4

■ Dimensions

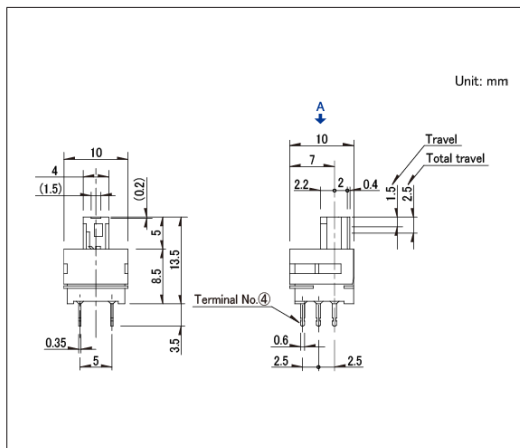

■ Mounting Hole Dimensions

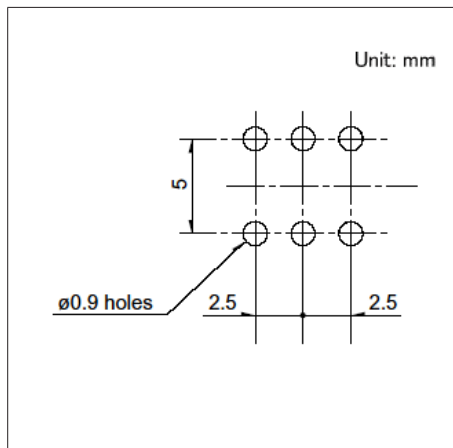

■ Circuit Diagram

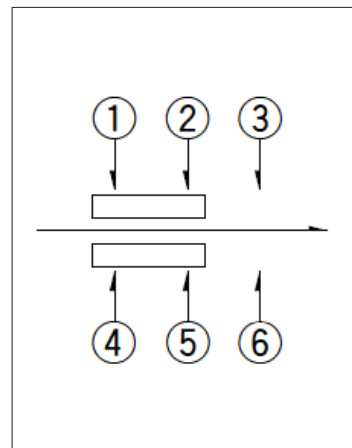

Viewed from direction A in the dimensions.

Drawing No.5

■ Dimensions

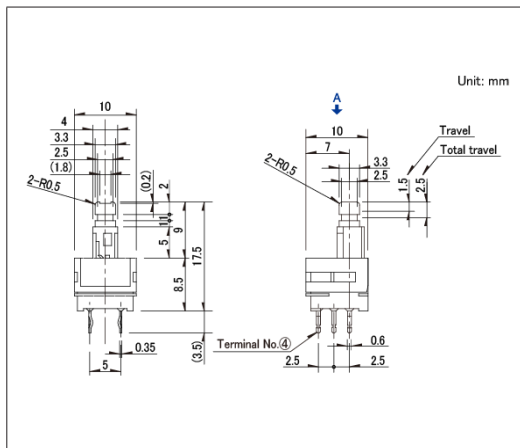

■ Mounting Hole Dimensions

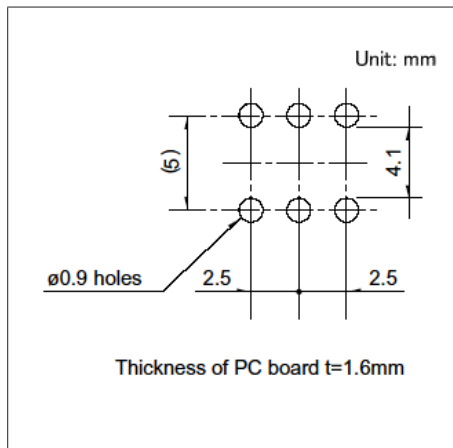

■ Circuit Diagram

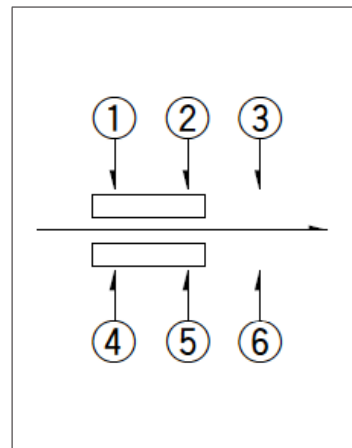

Viewed from direction A in the dimensions.

Drawing No.6

■ Dimensions

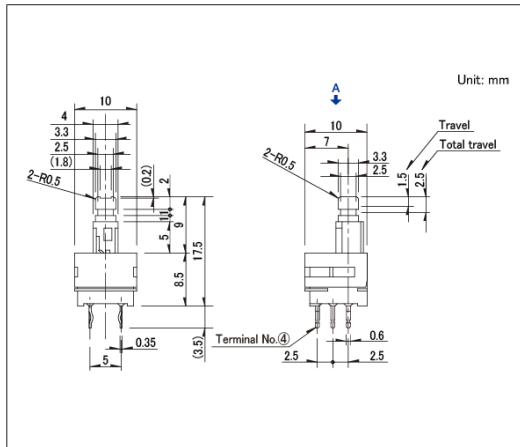

■ Mounting Hole Dimensions

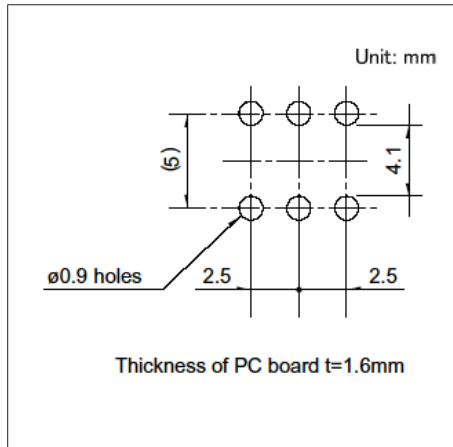

■ Circuit Diagram

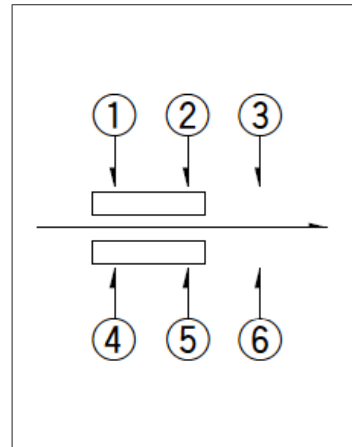

Viewed from direction A in the dimensions.

1.5mm-travel Vertical Type
SPPH1 Series

Drawing No.7

■ Dimensions

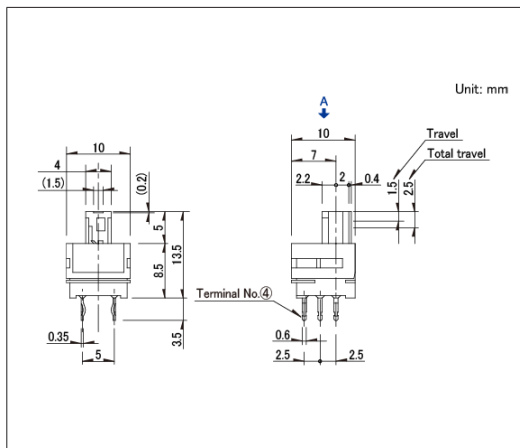

■ Mounting Hole Dimensions

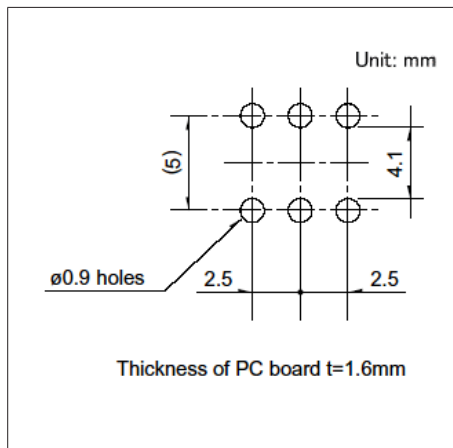

■ Circuit Diagram

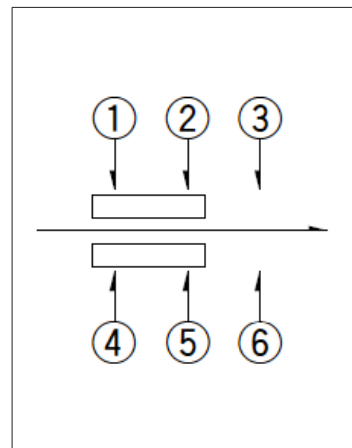

Viewed from direction A in the dimensions.

Drawing No.8

■ Dimensions

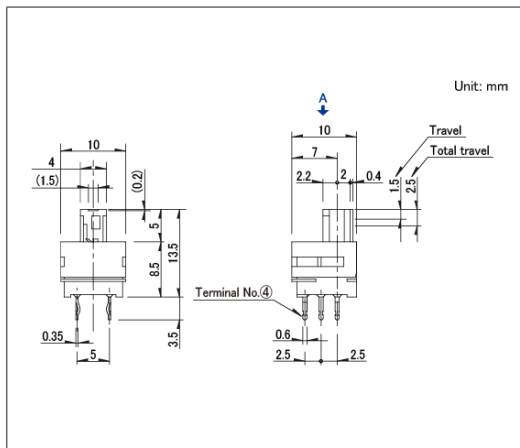

■ Mounting Hole Dimensions

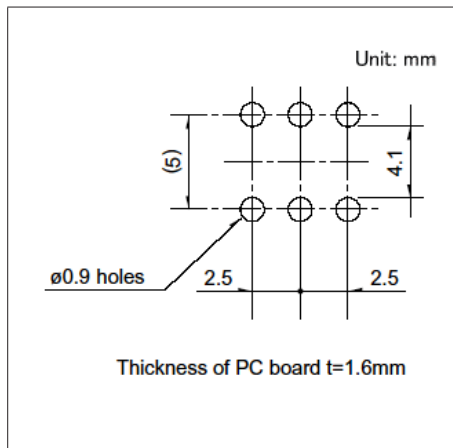

■ Circuit Diagram

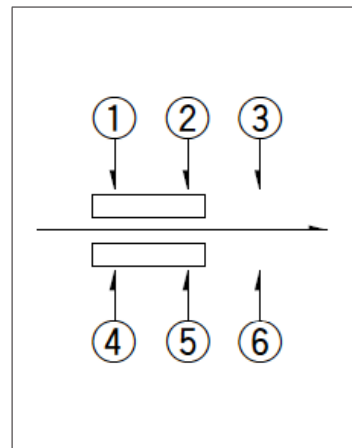

Viewed from direction A in the dimensions.

Drawing No.9

■ Dimensions

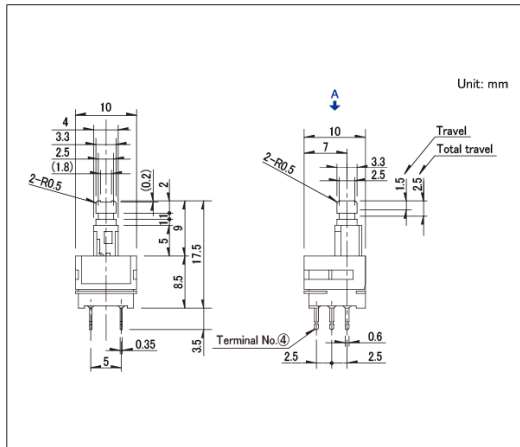

■ Mounting Hole Dimensions

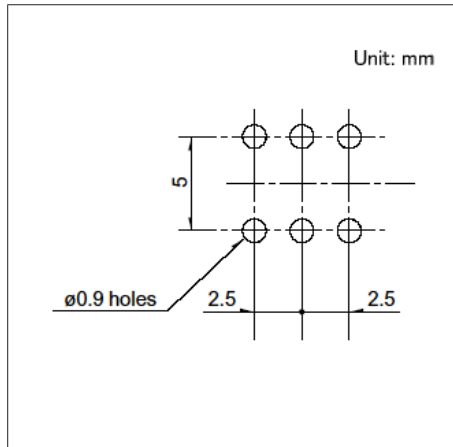

■ Circuit Diagram

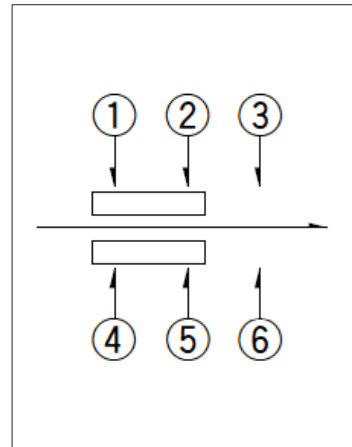

Viewed from direction A in the dimensions.

1.5mm-travel Vertical Type
SPPH1 Series

Drawing No.10

■ Dimensions

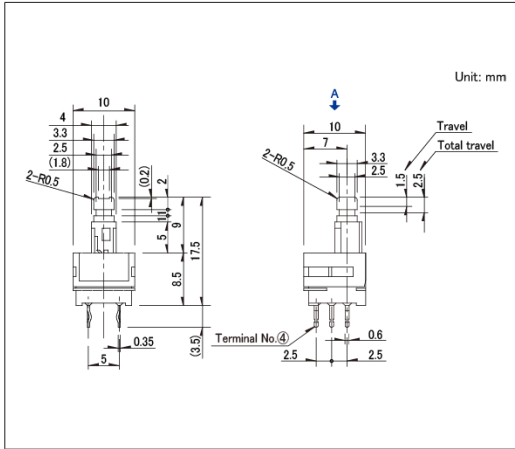

■ Mounting Hole Dimensions

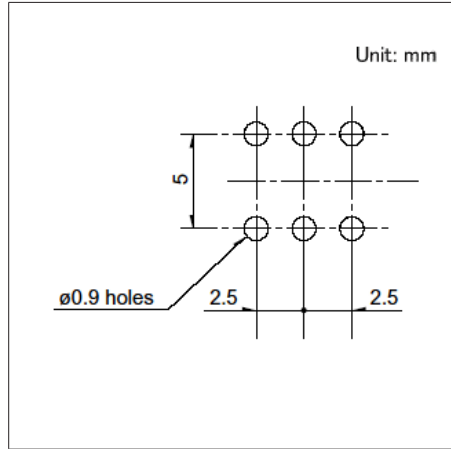

■ Circuit Diagram

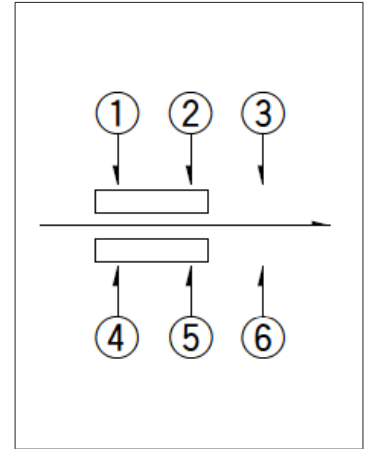

Viewed from direction A in the dimensions.

Drawing No.11

■ Dimensions

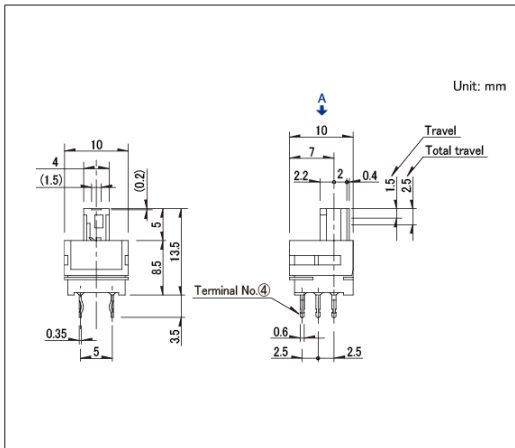

■ Mounting Hole Dimensions

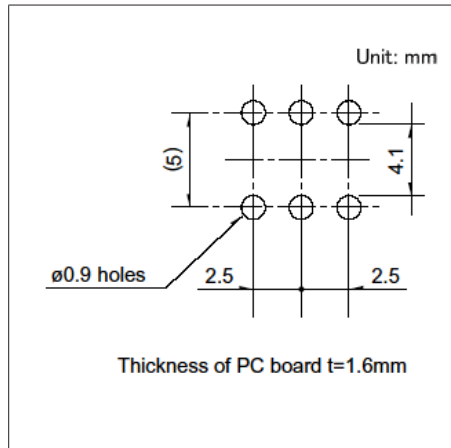

■ Circuit Diagram

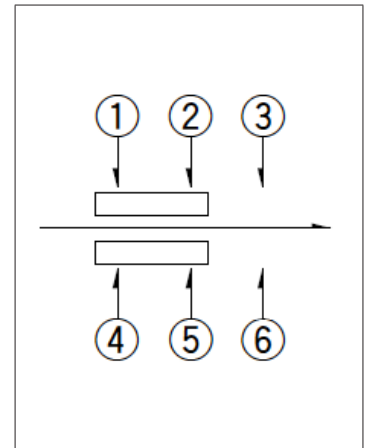

Viewed from direction A in the dimensions.

Switches

Push Switches

1.5mm-travel Vertical Type
SPEF Series

Supports surface mounting with lead-free solder.

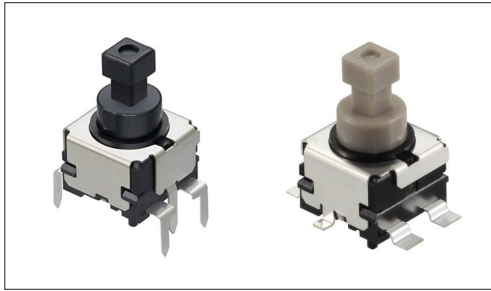
 Automotive

- Rating (max.)/(min.) (Resistive load): 1A 14.5V DC/50 μ A 3V DC
- Contact resistance (Initial performance/After lifetime): 100m Ω max./1 Ω max.
- Operating life with load (at max. rated load): 30,000 cycles 100m Ω max.

Applications: Automotive: Map Lamp, Hazard Lights

■ Product List

Products No.	Travel (mm)	Total travel (mm)	Poles	Positions	Operating force	Changeover timing	Mounting method	Operation	Terminal type	Dimensions (W×D×H) (mm)	Automotive	Drawing No.
SPEF210101	1.5	2.7	1	2	3N	Non shorting	PC board	Latching	Reflow	9.4×9.0×6.9	●	1
SPEF110100	1.5	2.7	1	2	3N	Non shorting	PC board	Latching	Dip	9.4×9.0×6.9	●	2
SPEF210200	1.5	2.7	1	2	5N	Non shorting	PC board	Latching	Reflow	9.4×9.0×6.9	●	1
SPEF110200	1.5	2.7	1	2	5N	Non shorting	PC board	Latching	Dip	9.4×9.0×6.9	●	2
SPEF220100	—	2.7	1	2	3N	Non shorting	PC board	Alternate	Reflow	9.4×9.0×6.9	●	3
SPEF120100	—	2.7	1	2	3N	Non shorting	PC board	Alternate	Dip	9.4×9.0×6.9	●	4
SPEF220200	—	2.7	1	2	5N	Non shorting	PC board	Alternate	Reflow	9.4×9.0×6.9	●	3
SPEF120200	—	2.7	1	2	5N	Non shorting	PC board	Alternate	Dip	9.4×9.0×6.9	●	4

 Note

1. This catalog shows only outline specifications. When using the products, please obtain formal specifications for supply.
2. Please place purchase orders per minimum order unit (integer).
3. This products can be used in vehicles.

Although these products are designed to perform over a wide operating temperature range, please ensure that you receive and read the formal delivery specifications before use.

■ Packing Specifications

Taping

Products No.	Number of packages(pcs.)			Tape width (mm)	Export package measurements (mm)
	1 reel	1 case / Japan	1 case / export packing		
SPEF210101 SPEF210200 SPEF220100 SPEF220200	165	660	1,320	32	403×403×360

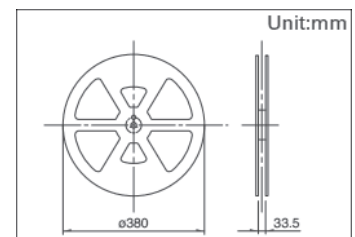

Tray

Products No.	Number of packages(pcs.)		Export package measurements (mm)
	1 case / Japan	1 case / export packing	
SPEF110100 SPEF110200 SPEF120100 SPEF120200	1,050	4,200	540 x 360 x 230

1.5mm-travel Vertical Type
SPEF Series

Drawing No.4

■ Dimensions

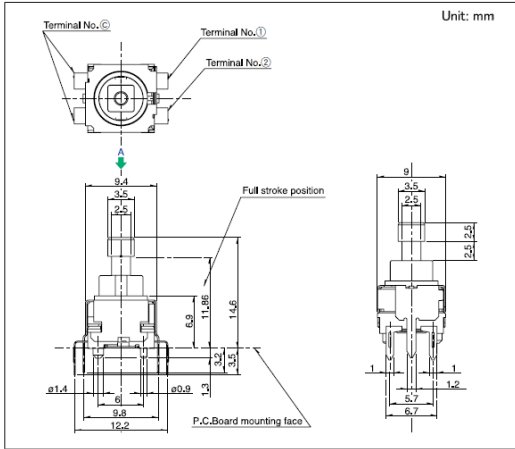

■ Land Dimensions

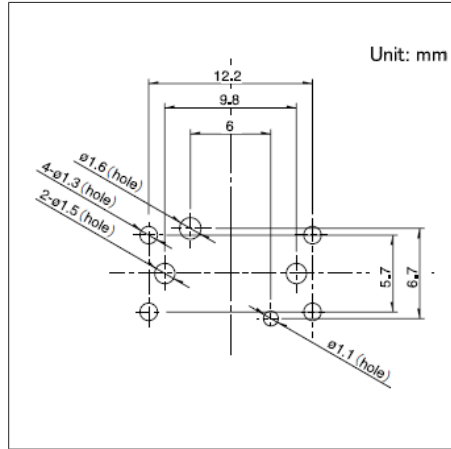

■ Circuit Diagram

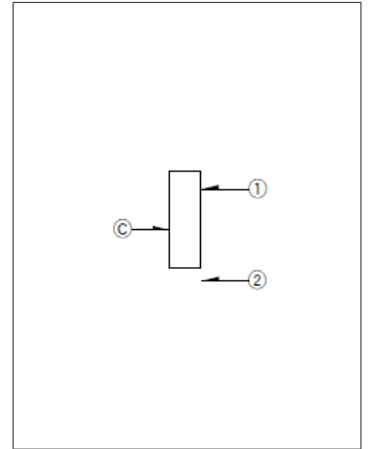

Viewed from direction A in the dimensions.

Switches Push Switches

4.5mm-travel Push-push Type
SPED2 Series

Provides smooth and linear operation feel.

Automotive

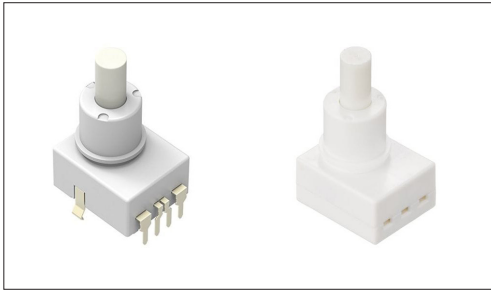

- Rating (max.)/(min.) (Resistive load): 1A 14.5V DC / -
- Contact resistance (Initial performance/After lifetime):
100mΩ max./100mΩ max.
- Operating life with load (at max. rated load): 30,000 cycles 100mΩ max.

Applications: Automotive: Map Lamp

■ Product List

Products No.	Total travel (mm)	Poles	Positions	Operating force	Changeover timing	Mounting method	Operation	Terminal type	Dimensions (W×D×H) (mm)	Automotive	Drawing No.
SPED220200	4.5	2	1	4.17±0.74N	Non shorting	PC board	Alternate	For PC board	16.8×14.0×9.5	●	1
SPED210203	4.5	1	2	4.17±0.74N	Non shorting	Connector	Alternate	—	16.8×14.0×9.5	●	2

Note

1. This catalog shows only outline specifications. When using the products, please obtain formal specifications for supply.
2. Please place purchase orders per minimum order unit (integer).
3. This products can be used in vehicles.
Although these products are designed to perform over a wide operating temperature range, please ensure that you receive and read the formal delivery specifications before use.

■ Packing Specifications

Tray

Products No.	Number of packages(pcs.)		Export package measurements (mm)
	1 case / Japan	1 case / export packing	
SPED220200	280	1,120	555 x 375 x 223

Bulk

Products No.	Number of packages(pcs.)		Export package measurements (mm)
	1 case / Japan	1 case / export packing	
SPED210203	400	2,000	400 x 270 x 290

Drawing No. 1

■ Dimensions

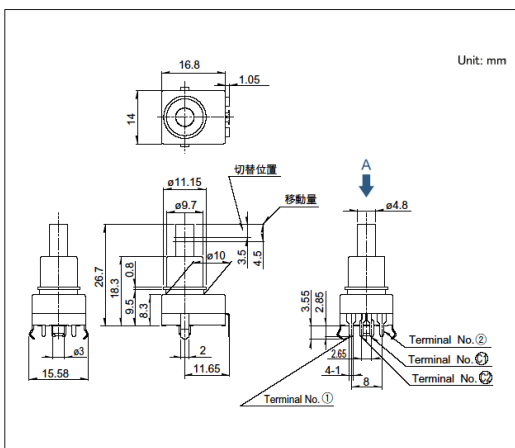

■ Mounting Hole Dimensions

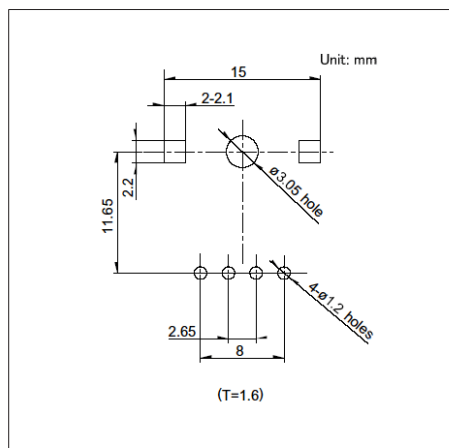

Viewed from direction A in the dimensions.

■ Circuit Diagram

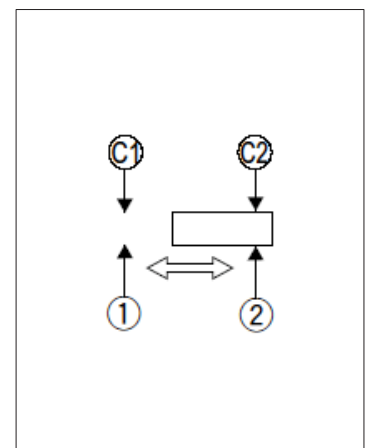

Factory setting for contact points can be either 1 or 2.

4.5mm-travel Push-push Type
SPED2 Series

Drawing No.2

■ Dimensions

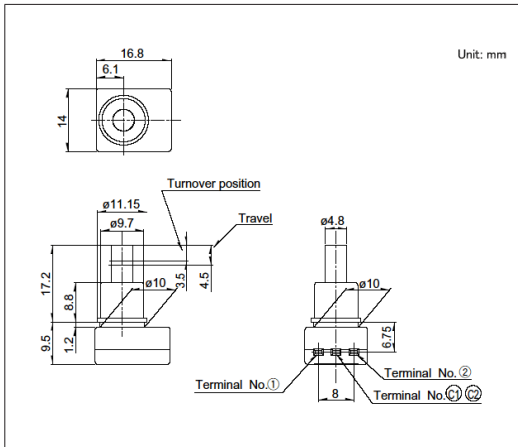

■ Circuit Diagram

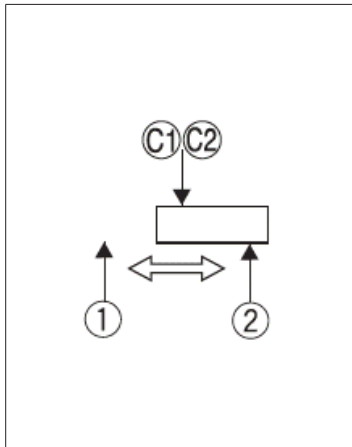

Factory setting for contact points can be either 1 or 2.

3.8mm-travel Push-push Type SPED3 Series

Provides smooth and linear operation feel.

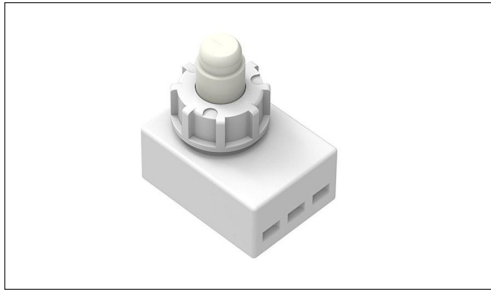

 Automotive

- Rating (max.)/(min.) (Resistive load): 2A 14.5V DC/ -
- Contact resistance (Initial performance/After lifetime):
100mΩ max./100mΩ max.
- Operating life with load (at max. rated load): 30,000 cycles 100mΩ max.

Applications: Automotive: Map Lamp

Product List

Products No.	Total travel (mm)	Poles	Positions	Operating force	Changeover timing	Mounting method	Operation	Dimensions (W×D×H) (mm)	Automotive	Drawing No.
SPED310200	3.8	1	2	4.17±0.74N	Non shorting	Connector	Alternate	18.0×14.0×7.4	●	1

Note

1. This catalog shows only outline specifications. When using the products, please obtain formal specifications for supply.
2. Please place purchase orders per minimum order unit (integer).
3. This products can be used in vehicles.
Although these products are designed to perform over a wide operating temperature range, please ensure that you receive and read the formal delivery specifications before use.

Packing Specifications

Bulk

Number of packages (pcs.)		Export package measurements (mm)
1 case / Japan	1 case / export packing	
500	2,500	400 x 270 x 290

Drawing No.1

Dimensions

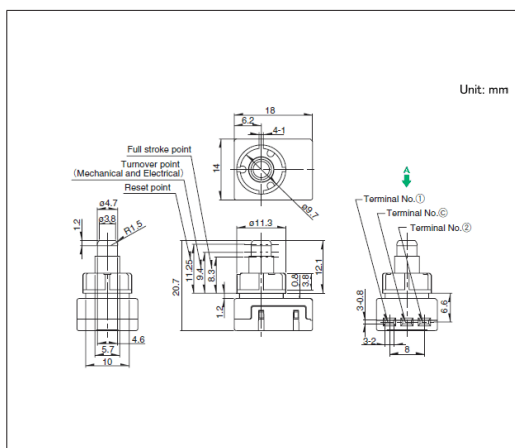

Circuit Diagram

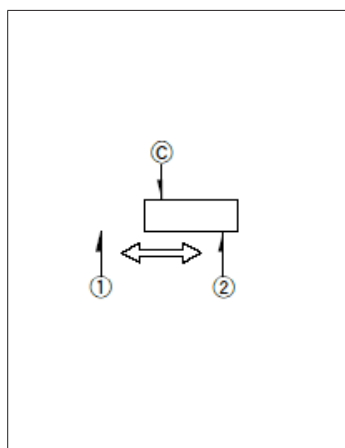

Factory setting for contact points can be either 1 or 2.

Switches Push Switches

3.8mm-travel Push-push Type
SPED4 Series

Provides smooth and linear operation feel.

Automotive

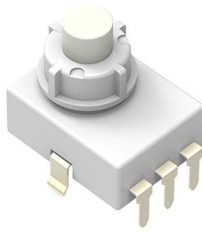

- Rating (max.)/(min.) (Resistive load): 2A 14.5V DC/ -
- Contact resistance (Initial performance/After lifetime):
100mΩ max./100mΩ max.
- Operating life with load (at max. rated load): 30,000 cycles 100mΩ max.

Applications: Automotive: Map Lamp

■ Product List

Products No.	Total travel (mm)	Poles	Positions	Operating force	Changeover timing	Mounting method	Operation	Terminal type	Dimensions (W×D×H) (mm)	Automotive	Drawing No.
SPED420200	3.8	1	2	4.17±0.74N	Non shorting	PC board	Alternate	For PC board	18.0×14.0×7.27		1

Note

1. This catalog shows only outline specifications. When using the products, please obtain formal specifications for supply.
2. Please place purchase orders per minimum order unit (integer).
3. This products can be used in vehicles.
Although these products are designed to perform over a wide operating temperature range, please ensure that you receive and read the formal delivery specifications before use.

■ Packing Specifications

Tray

Number of packages (pcs.)		Export package measurements (mm)
1 case / Japan	1 case / export packing	
280	1,120	555 x 375 x 223

Drawing No.1

■ Dimensions

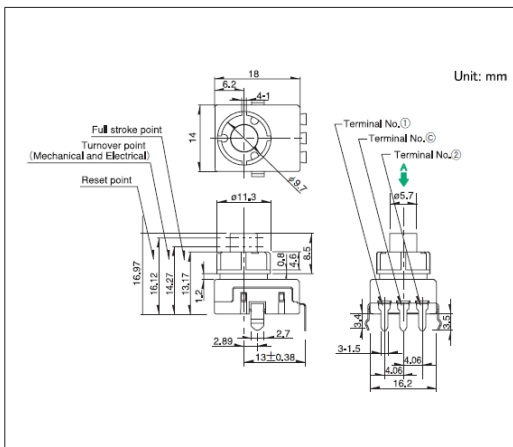

■ Mounting Hole Dimensions

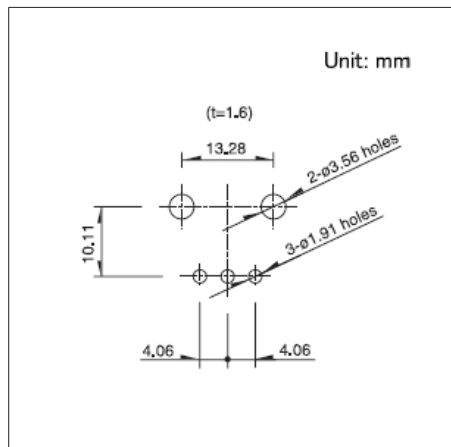

Viewed from direction A in the dimensions.

■ Circuit Diagram

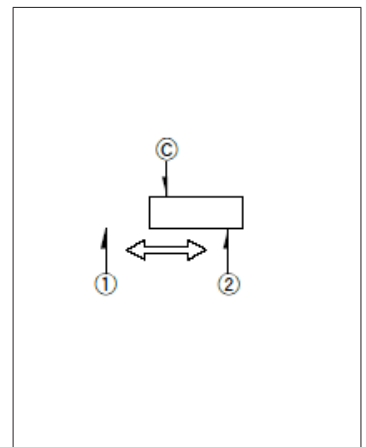

Factory setting for contact points can be either 1 or 2.

Push Switches / Soldering Conditions

■ Example of Reflow Soldering Condition

1. Heating method: Double heating method with infrared heater.
2. Temperature measurement: Thermocouple ϕ 0.1 to 0.2 CA (K) or CC (T) at soldering portion (copper foil surface).
A heat resisting tape should be used for fixed measurement.
3. Temperature profile

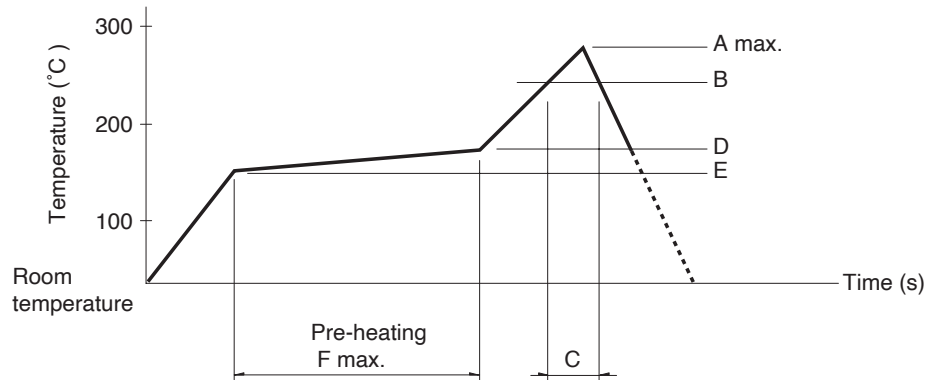

Series (Reflow type)	A (°C) 3s max.	B (°C)	C (s)	D (°C)	E (°C)	F (s)
SPEJ	260	230	40	180	150	120
SPEF						

⚠ Note

1. The condition mentioned above is the temperature on the mounting surface of a PC board. There are cases where the PC board's temperature greatly differs from that of the switch, depending on the PC board's material, size, thickness, etc.
The above-stated conditions shall also apply to switch surface temperatures.
2. Soldering conditions differ depending on reflow soldering machines. Prior verification of soldering condition is highly recommended.

■ Reference for Hand Soldering

Series	Soldering temperature	Soldering time
SPPJ3, SPPJ2, SPUN, SPUJ, SPPH4, SPPH1	350±10°C	3+1/0s
SPED2, SPED4	350±10°C	3±0.5s
SPEJ	350±10°C	4s max.
SPEF	350±5°C	3s max.

■ Reference for Dip Soldering

(For PC board terminal types)

Series	Items		Dip soldering	
	Preheating temperature	Preheating time	Soldering temperature	Duration of immersion
SPPJ3	100°C max.	60s max.	260±5°C	5±1s
SPUN	100°C max.	60s max.	260±5°C	10±1s
SPUJ, SPPH4	—	—	260±5°C	5±1s
SPPJ2, SPPH1, SPED2, SPED4, SPEF	—	—	260±5°C	10±1s





Push Switches / Cautions

1. Applying load to terminals during soldering under certain conditions may cause deformation and electrical property degradation.
2. Avoid use of water-soluble soldering flux, since it may corrode the switches.
3. Check and conform to soldering requirements under actual mass production conditions.
4. When soldering twice, wait until the first soldered portion cools to normal temperature. Continuous heating will deform the external portions, loosen or dislodge terminals, or may deteriorate their electrical characteristics.
5. Flux from around and above the PC board should not adhere to the switches.
6. After mounting the switches, if you intend to put the board into an oven in order to harden adhesive for other parts, please consult with us.
7. Before soldering switches with locking mechanism, release the locks. If they are soldered without releasing the locks, the soldering heat may deform the locking mechanism.
8. If you use a through-hole PC board or a PC board thinner or thicker than the recommendation, there may be greater heat stress. Verify the soldering conditions thoroughly before use.
9. Solder the switches with detent at the detent position. Soldering switches fixed at the center of the detent may deform the detent mechanisms.
10. No cleaning.
11. Protect small and thin switches from external forces in the set mounting process.
12. Tighten the mounting screws by applying the specified torque. Tightening with larger torque than the specified one will result in malfunction or breakage of screws.
13. The products are designed and manufactured for direct current resistance. Contact us for use of other resistances such as inductive (L) or capacitive (C).
14. The switch will break if you apply a greater stress than that specified. Take great care not to let the switch be subject to greater stress than specified.
15. Be sure to release the locks before removing the knobs. Otherwise, the locking mechanism may be deformed.
16. Be sure to use the forced travel close to the position of the whole travel as much as possible.
17. Insert these switches to the specified mounting surface and mount them horizontally. If not mounted horizontally, these switches will malfunction.
18. Use of the switches in a dusty environment may lead to dusts entering through the openings and cause imperfect contact or malfunction. Take this into account for set design.
19. Corrosive gas if generated by peripheral parts of a set, malfunction such as imperfect contact may occur. Thorough investigation shall be required beforehand.
20. Storage
Store the products as delivered at normal temperature and humidity, out of direct sunlight and away from corrosive gases. Use them as soon as possible and no later than six months after delivery.
Once the seal is broken, use them as soon as possible.

Switches

Rotary Switches

List of Varieties

Series		SRBD	SRBQ	SRBM	SRBV	
Photo						
Dimensions (mm)		10.0×10.0×1.7	11.4×12.4×3.1 11.4×12.4×3.5	10.0×12.5×11.5 10.0×12.9×11.5	16.2×18.5×7.5	
Changeover angle		36°	40±3°	18±3° 30±3°	30±3°	
Poles		1		1 2	1	
Rotational torque		13±5mN·m	6±3mN·m 13±5mN·m	15±7mN·m 40±20mN·m	30±15mN·m	
Operating temperature range		-25°C to +85°C	-10°C to +60°C	-30°C to +85°C	-10°C to +85°C	
Rating (max.)/(min.) (Resistive load)		1mA 5V DC/50μA 3V DC	0.1A 16V DC/50μA 3V DC		0.3A 16V DC/50μA 3V DC	
Electrical performance	Contact resistance (Initial performance/ After lifetime)	200mΩ max./250mΩ max.	50mΩ max./100mΩ max.	50mΩ max./150mΩ max.		
	Insulation resistance	100MΩ min. 100V DC				
	Voltage proof	100V AC for 1 minute				
Mechanical performance	Terminal strength	3N for 1 minute	5N for 1 minute			
	Actuator strength	Rotational direction	—		0.5N·m	0.6N·m
		Push direction	50N	20N	100N	
Durability	Operating life without load	10,000 cycles 250mΩ max.	10,000 cycles 100mΩ max.	10,000 cycles 100mΩ max. 30,000 cycles 100mΩ max.	10,000 cycles 100mΩ max.	
	Operating life with load (at max. rated load)	10,000 cycles 250mΩ max.	10,000 cycles 100mΩ max.	10,000 cycles 150mΩ max.		
Environmental performance	Cold	-40°C 500h	-20°C 96h	-40°C 96h	-20°C 96h	
	Dry heat	85°C 500h	85°C 96h			
	Damp heat	60°C, 90 to 95%RH 500h	40°C, 90 to 95%RH 96h			
Automotive		—	—	—	—	



● Indicates applicability to all products in the series, while ○ indicates applicability to some products in the series.

Switches Rotary Switches

Heavy-torque Feel, Low-profile Type SRBD Series

Mode selector switch capable of up to 10 positions.

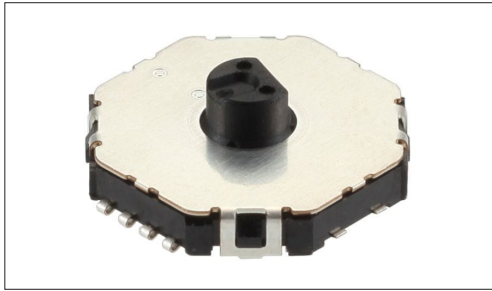

- Rating (max.)/(min.) (Resistive load): 1mA 5V DC/50μA 3V DC
- Contact resistance (Initial performance/After lifetime):
200mΩ max./250mΩ max.
- Operating life without load: 10,000 cycles 250mΩ max.
- Operating life with load (at max. rated load): 10,000 cycles 250mΩ max.

Applications: Healthcare: Healthcare equipment
Audio_TV: Cameras

■ Product List

Products No.	Poles	Positions	Changeover angle	Detent	Location lug	Changeover timing	Rotational torque	Soldering	Actuator length	Dimensions (WxDxH) (mm)	Automotive	Drawing No.
SRBD150201	1	10	36°	5	with	Non shorting	13±5mN·m	For PC board (Reflow)	1.7mm	10.0x10.0x1.7	—	1
SRBD170401	1	10	36°	7	without	Non shorting	13±5mN·m	For PC board (Reflow)	1.7mm	10.0x10.0x1.7	—	2
SRBD180201	1	10	36°	8	with	Non shorting	13±5mN·m	For PC board (Reflow)	1.7mm	10.0x10.0x1.7	—	3
SRBD110401	1	10	36°	10	with	Non shorting	13±5mN·m	For PC board (Reflow)	1.7mm	10.0x10.0x1.7	—	4

⚠ Note

1. This catalog shows only outline specifications. When using the products, please obtain formal specifications for supply.
2. Please place purchase orders for taping products per minimum order unit (1 reel or a case).

■ Packing Specifications

Taping

Number of packages (pcs.)			Tape width (mm)	Export package measurements (mm)
1 reel	1 case / Japan	1 case / export packing		
1,200	2,400	4,800	24	428 x 413 x 172

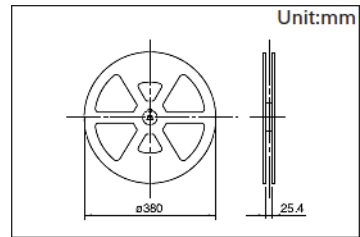

Drawing No.1

■ Dimensions

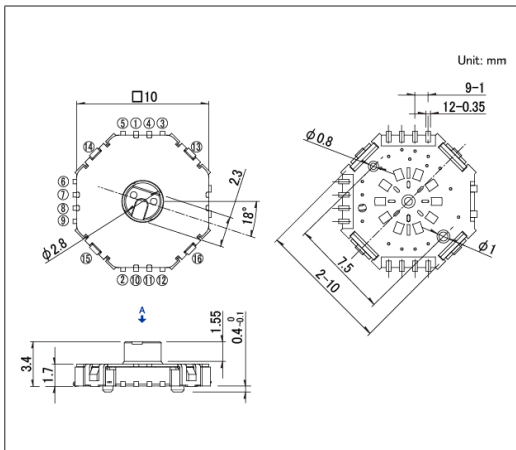

■ Land Dimensions

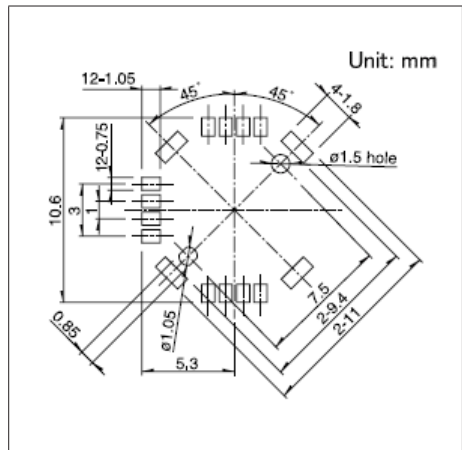

■ Circuit Diagram

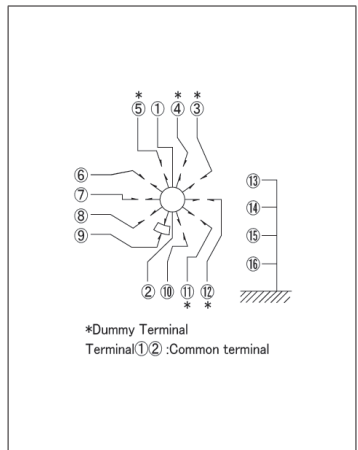

Viewed from direction A in the dimensions.

Switches Rotary Switches

Heavy-torque Feel, Low-profile Type
SRBD Series

Drawing No.2

■ Dimensions

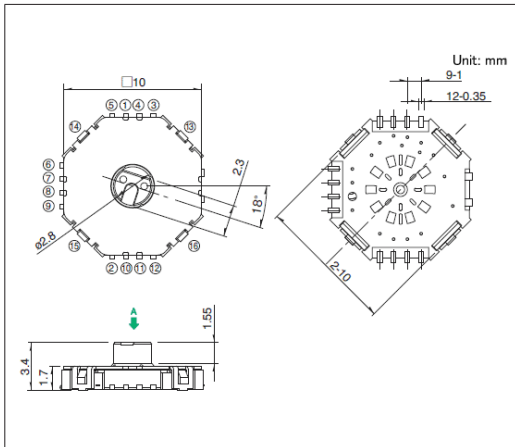

■ Land Dimensions

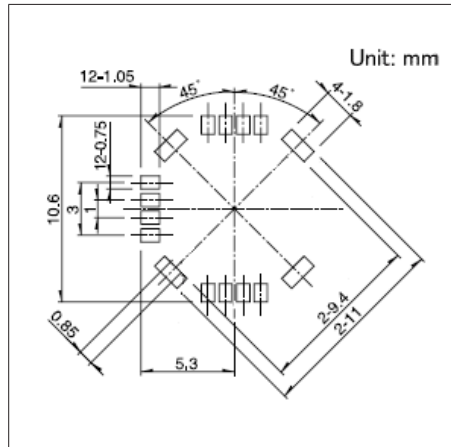

■ Circuit Diagram

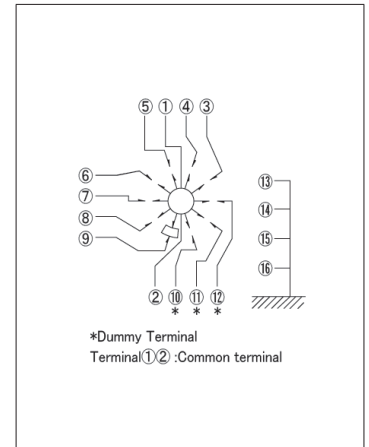

Viewed from direction A in the dimensions.

Drawing No.3

■ Dimensions

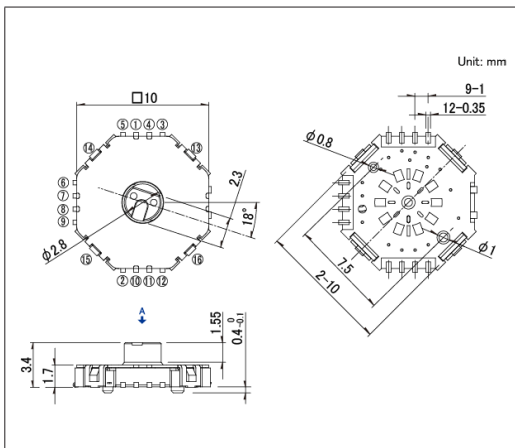

■ Land Dimensions

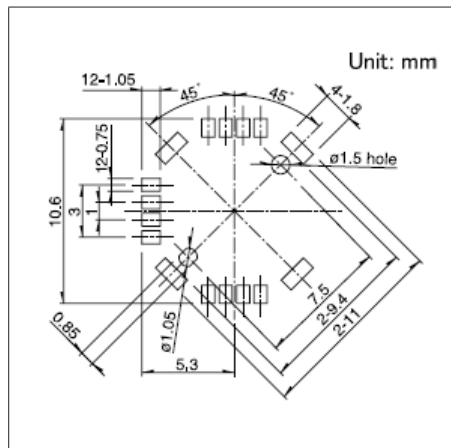

■ Circuit Diagram

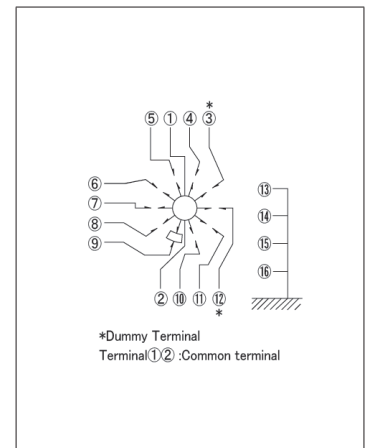

Viewed from direction A in the dimensions.

Drawing No.4

■ Dimensions

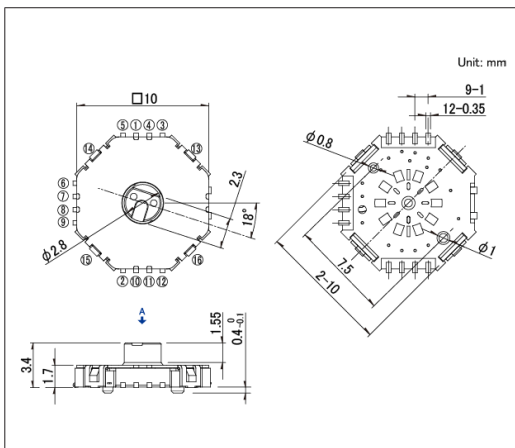

■ Land Dimensions

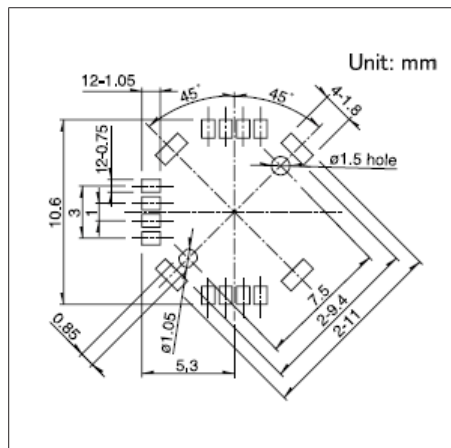

■ Circuit Diagram

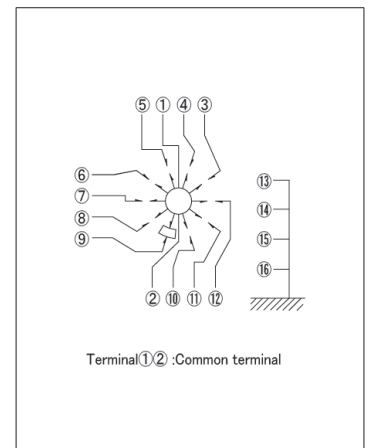

Viewed from direction A in the dimensions.

Switches Rotary Switches

9-positions Low-profile Vertical Type SRBQ Series

Unique detent mechanism delivering a light operation feel with a thin profile.

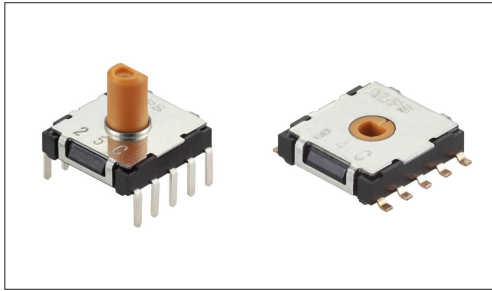

- Rating (max.)/(min.) (Resistive load): 0.1 A 16V DC/50 μ A 3V DC
- Contact resistance (Initial performance/After lifetime):
50m Ω max./100m Ω max.
- Operating life without load: 10,000 cycles 100m Ω max.
- Operating life with load (at max. rated load): 10,000 cycles 100m Ω max.

Applications: Home: Major home appliances

Product List

Products No.	Poles	Positions	Changeover angle	Changeover timing	Rotational torque	Soldering	Actuator configuration	Actuator length	Dimensions (WxDxH) (mm)	Automotive	Drawing No.
SRBQ090200	1	9	40 \pm 3 $^\circ$	Non shorting	6 \pm 3mN·m	Insertion	Flat	5.8mm	11.4 \times 12.4 \times 3.5	—	1
SRBQ490100	1	9	40 \pm 3 $^\circ$	Non shorting	13 \pm 5mN·m	Insertion	Flat	5.8mm	11.4 \times 12.4 \times 3.5	—	2
SRBQ290301	1	9	40 \pm 3 $^\circ$	Non shorting	6 \pm 3mN·m	Reflow	Non shaft	—	11.4 \times 12.4 \times 3.1	—	3

⚠ Note

1. This catalog shows only outline specifications. When using the products, please obtain formal specifications for supply.
2. Please place purchase orders per minimum order unit (integer).
3. Please place purchase orders for taping products per minimum order unit (1 reel or a case).

Packing Specifications

Bulk

Products No.	Number of packages(pcs.)		Export package measurements (mm)
	1 case / Japan	1 case / export packing	
SRBQ090200 SRBQ490100	1,215	4,860	540 x 360 x 290

Taping

Products No.	Number of packages(pcs.)			Tape width (mm)	Export package measurements (mm)
	1 reel	1 case / Japan	1 case / export packing		
SRBQ290301	1,200	2,400	4,800	24	406 x 406 x 190

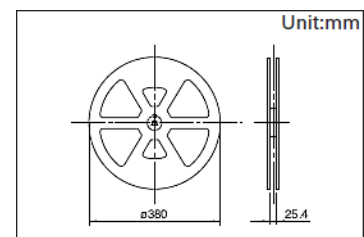

9-positions Low-profile Vertical Type
SRBQ Series

Drawing No.1

■ Dimensions

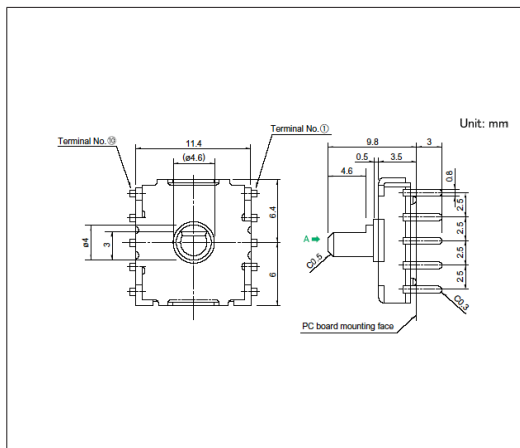

Standard torque

■ Mounting Hole Dimensions

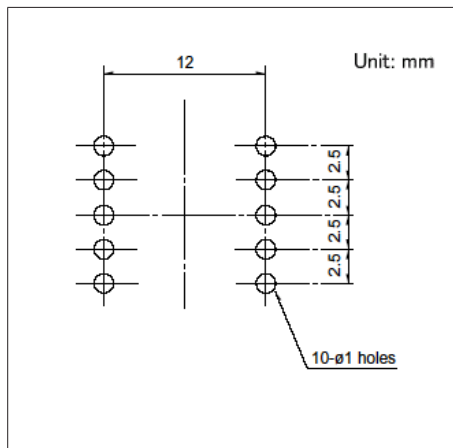

Viewed from direction A in the dimensions.

■ Circuit Diagram

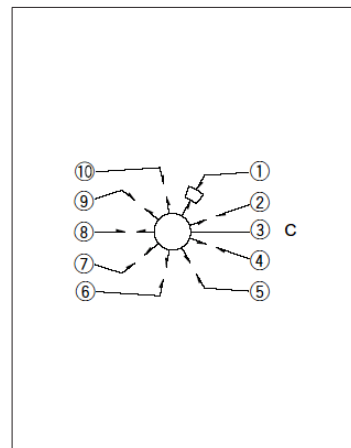

Drawing No.2

■ Dimensions

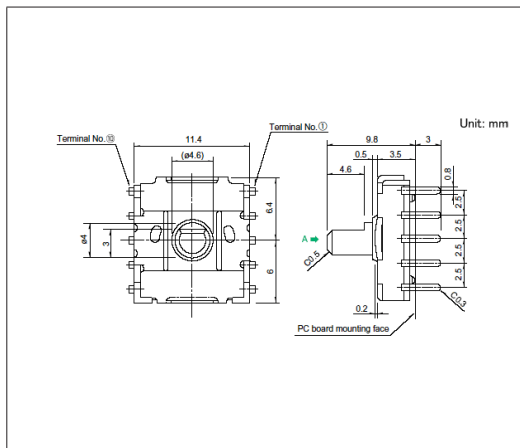

Heavy torque

■ Mounting Hole Dimensions

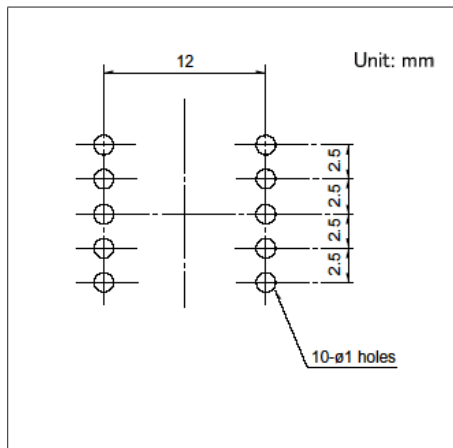

Viewed from direction A in the dimensions.

■ Circuit Diagram

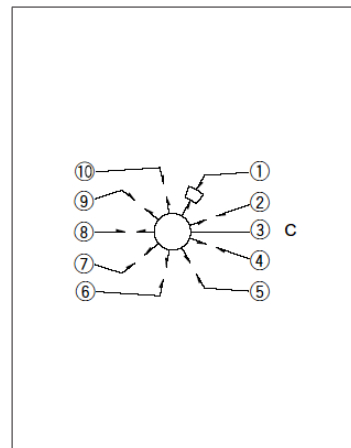

Drawing No.3

■ Dimensions

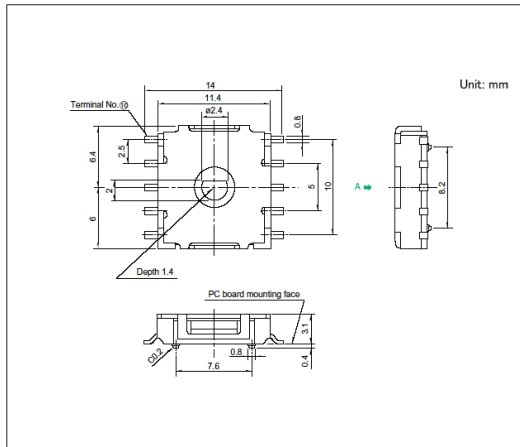

■ Land Dimensions

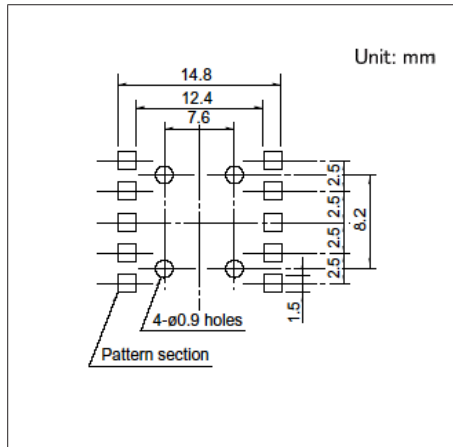

Viewed from direction A in the dimensions.

■ Circuit Diagram

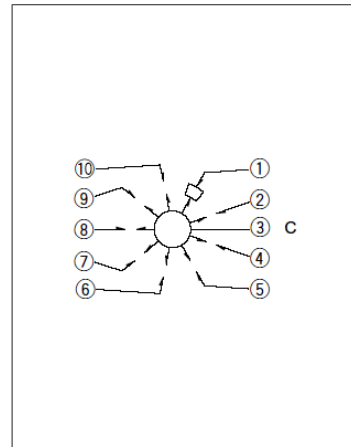

Switches Rotary Switches

6-positions Horizontal Type SRBM Series

Same shape available as a pulse switch (20 pulses).



- Rating (max.)/(min.) (Resistive load): 0.1 A 16V DC/50μA 3V DC
- Contact resistance (Initial performance/After lifetime):
50mΩ max./150mΩ max.
- Operating life without load: 10,000 cycles 100mΩ max.
- Operating life with load (at max. rated load): 10,000 cycles 150mΩ max.

Applications: Energy_Industrial: Industrial equipment

Product List

Products No.	Poles	Positions	Changeover angle	Changeover timing	Rotational torque	Actuator configuration	Actuator length	Dimensions (W×D×H) (mm)	Automotive	Drawing No.
SRBM120700	2	2	30±3°	Non shorting	40±20mN·m	18-tooth serration	L: 15mm	10.0×12.5×11.5	—	1
SRBM121300	2	2	30±3°	Non shorting	40±20mN·m	Flat	L: 15mm	10.0×12.5×11.5	—	2
SRBM131300	2	3	30±3°	Non shorting	40±20mN·m	18-tooth serration	L: 15mm	10.0×12.5×11.5	—	3
SRBM131400	2	3	30±3°	Non shorting	40±20mN·m	18-tooth serration	L: 20mm	10.0×12.5×11.5	—	
SRBM140700	2	4	30±3°	Non shorting	40±20mN·m	18-tooth serration	L: 15mm	10.0×12.5×11.5	—	4
SRBM140800	2	4	30±3°	Non shorting	40±20mN·m	18-tooth serration	L: 20mm	10.0×12.5×11.5	—	
SRBM149501	2	4	30±3°	Non shorting	40±20mN·m	Flat	L: 20mm	10.0×12.5×11.5	—	5
SRBM150500	1	5	30±3°	Non shorting	40±20mN·m	18-tooth serration	L: 15mm	10.0×12.5×11.5	—	6
SRBM154002	1	5	30±3°	Non shorting	40±20mN·m	Flat	L: 15mm	10.0×12.5×11.5	—	7
SRBM160700	1	6	30±3°	Non shorting	40±20mN·m	18-tooth serration	L: 15mm	10.0×12.5×11.5	—	8
SRBM1L0800	1	20-pulses	18±3°	—	15±7mN·m	18-tooth serration	L: 15mm	10.0×12.9×11.5	—	9
SRBM1L1400	1	20-pulses	18±3°	—	15±7mN·m	Flat	L: 15mm	10.0×12.9×11.5	—	10

⚠ Note

1. This catalog shows only outline specifications. When using the products, please obtain formal specifications for supply.
2. All the axis are die casting shafts.
3. Please place purchase orders per minimum order unit (integer).

Packing Specifications

Tray

Products No.	Number of packages (pcs.)		Export package measurements (mm)
	1 case / Japan	1 case / export packing	
SRBM120700 SRBM121300 SRBM131300 SRBM140700 SRBM150500 SRBM154002 SRBM160700 SRBM1L0800 SRBM1L1400	360	1,800	400 x 270 x 290
SRBM131400 SRBM140800 SRBM149501	210	1,050	400 x 270 x 290

6-positions Horizontal Type
SRBM Series

Drawing No.1

■ Dimensions

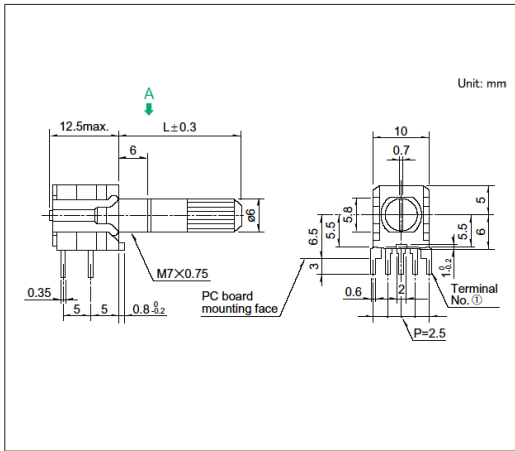

■ Mounting Hole Dimensions

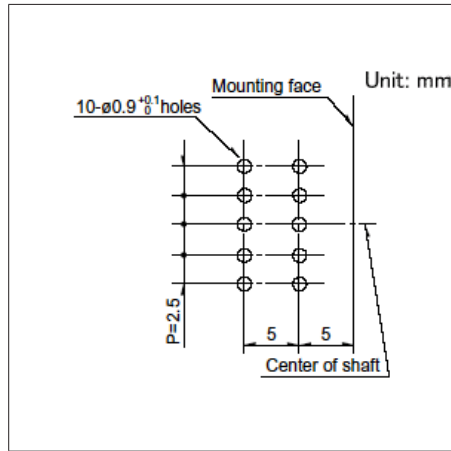

■ Circuit Diagram and Dummy Terminals

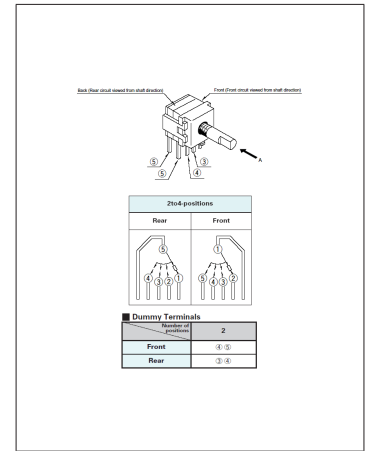

Viewed from direction A in the dimensions.

1. Viewed from direction A.
2. For positions 2, 1 section consists of 2-poles.

Drawing No.2

■ Dimensions

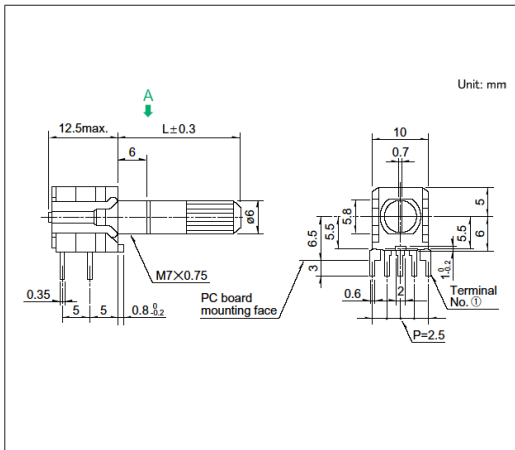

■ Mounting Hole Dimensions

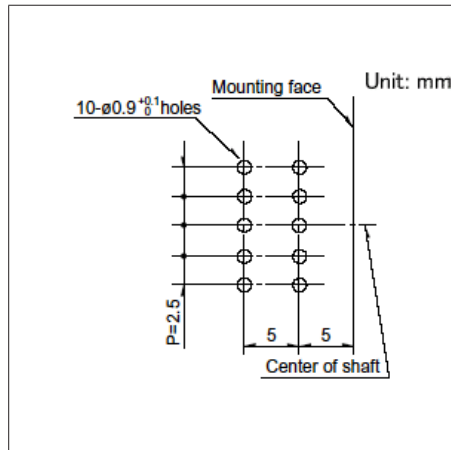

■ Circuit Diagram and Dummy Terminals

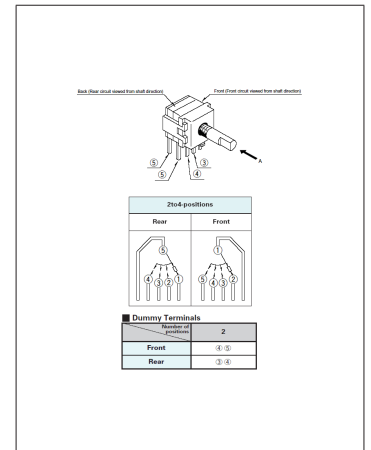

Viewed from direction A in the dimensions.

1. Viewed from direction A.
2. For positions 2, 1 section consists of 2-poles.

Drawing No.3

■ Dimensions

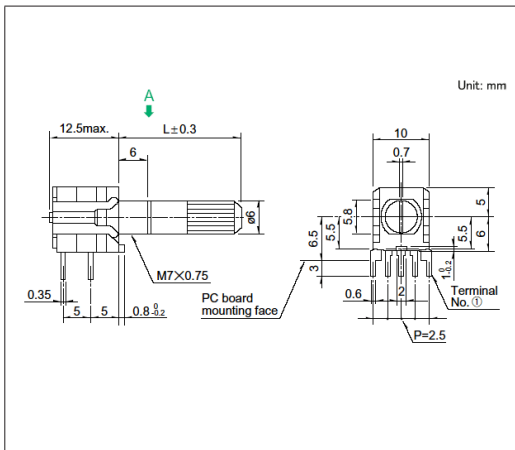

■ Mounting Hole Dimensions

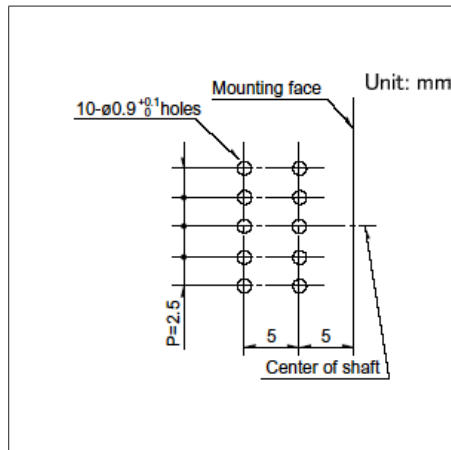

■ Circuit Diagram and Dummy Terminals

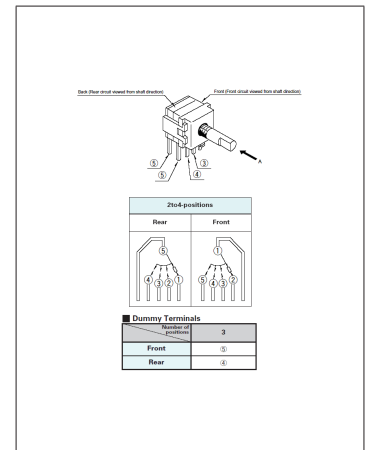

Viewed from direction A in the dimensions.

1. Viewed from direction A.
2. For positions 3, 1 section consists of 2-poles.

6-positions Horizontal Type
SRBM Series

Drawing No.4

■ Dimensions

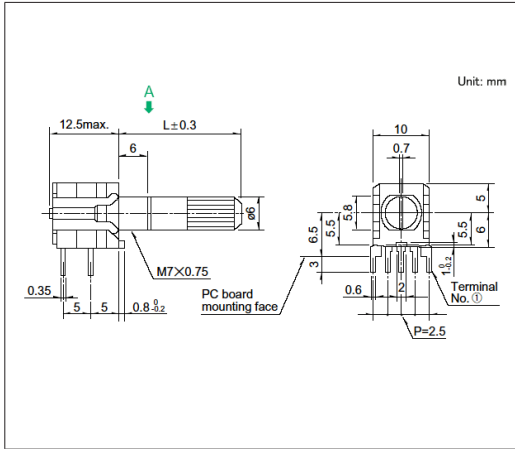

■ Mounting Hole Dimensions

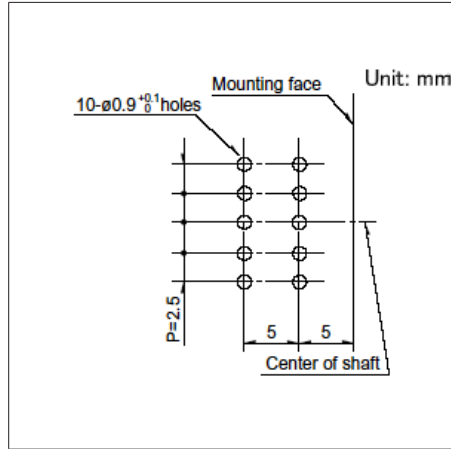

■ Circuit Diagram

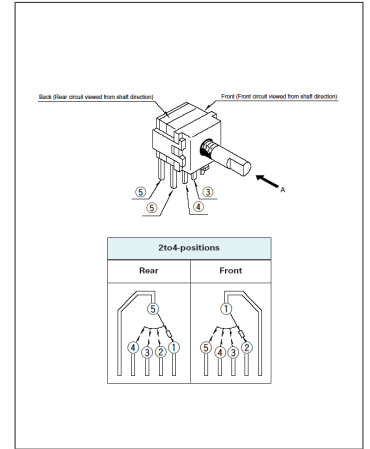

Viewed from direction A in the dimensions.

1. Viewed from direction A.
2. For positions 4, 1 section consists of 2-poles.

Drawing No.5

■ Dimensions

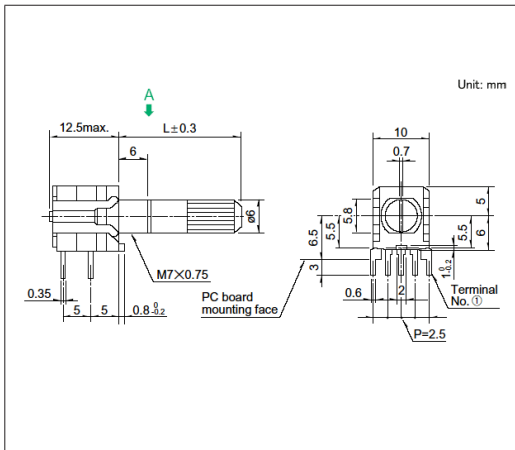

■ Mounting Hole Dimensions

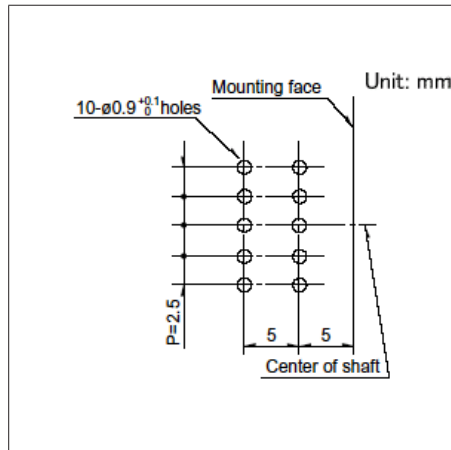

■ Circuit Diagram

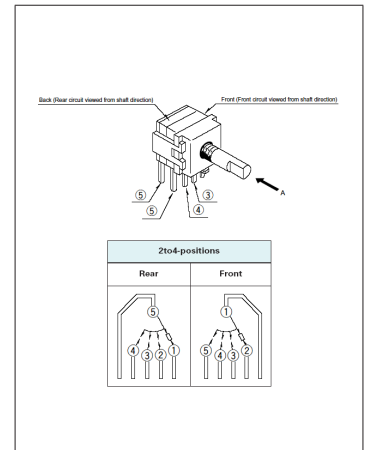

Viewed from direction A in the dimensions.

1. Viewed from direction A.
2. For positions 4, 1 section consists of 2-poles.

Drawing No.6

■ Dimensions

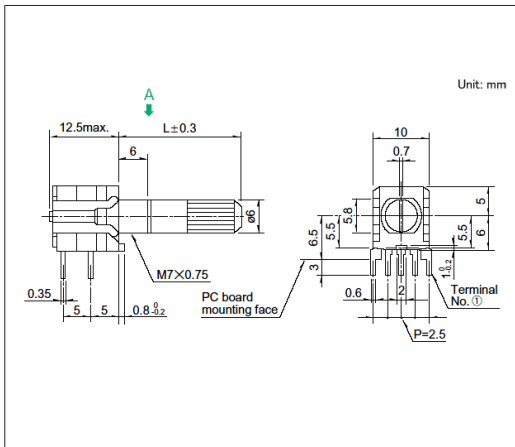

■ Mounting Hole Dimensions

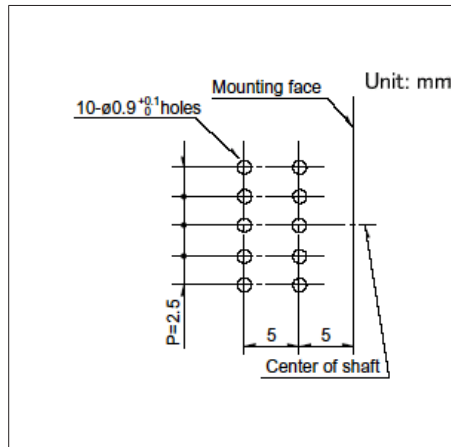

■ Circuit Diagram

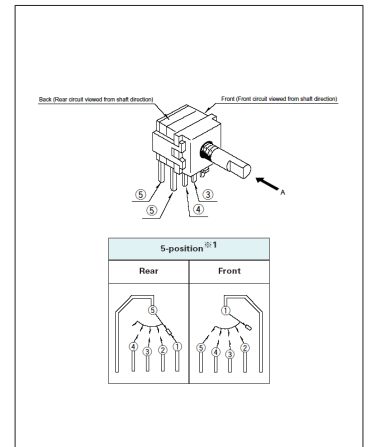

Viewed from direction A in the dimensions.

1. Viewed from direction A.
2. Circuit steps are 2 to 5 positions at front and 1 to 4 positions at rear.
3. It is necessary external wiring of common terminals.
4. For positions 5, 1 section consists of 1-pole.

6-positions Horizontal Type
SRBM Series

Drawing No.7

■ Dimensions

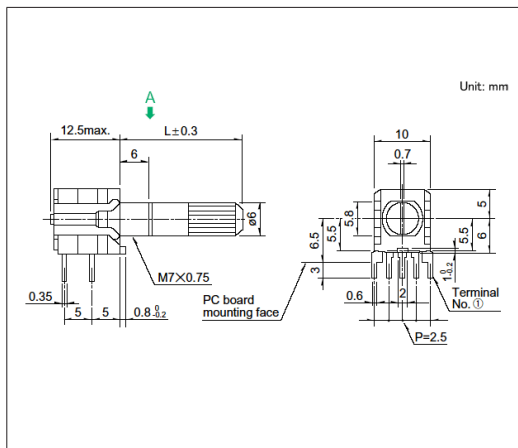

■ Mounting Hole Dimensions

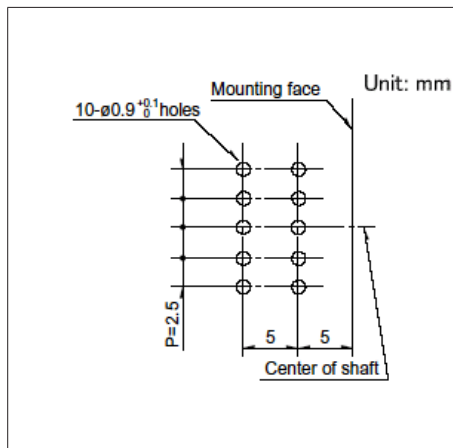

■ Circuit Diagram

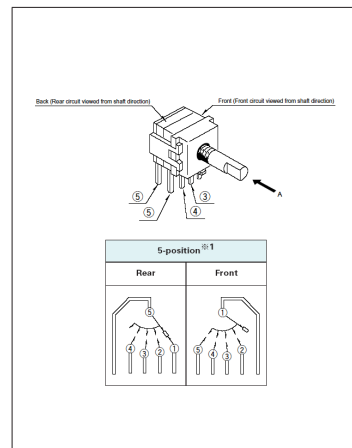

Viewed from direction A in the dimensions.

1. Viewed from direction A.
2. Circuit steps are 2 to 5 positions at front and 1 to 4 positions at rear.
3. It is necessary external wiring of common terminals.
4. For positions 5, 1 section consists of 1-pole.

Drawing No.8

■ Dimensions

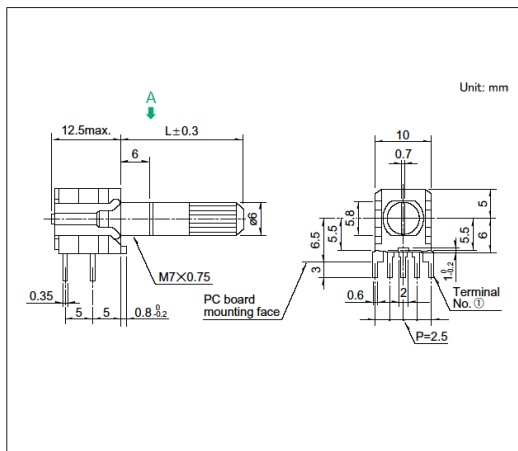

■ Mounting Hole Dimensions

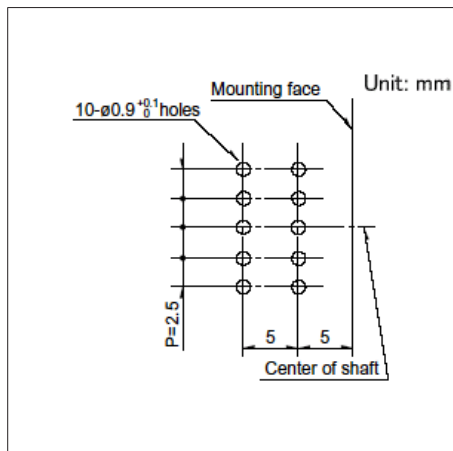

■ Circuit Diagram

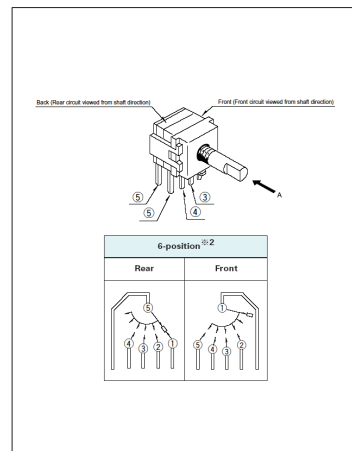

Viewed from direction A in the dimensions.

1. Viewed from direction A.
2. Circuit steps are 3 to 6 positions at front and 1 to 4 positions at rear.
3. It is necessary external wiring of common terminals.
4. For positions 6, 1 section consists of 1-pole.

6-positions Horizontal Type
SRBM Series

Drawing No.9

■ Dimensions

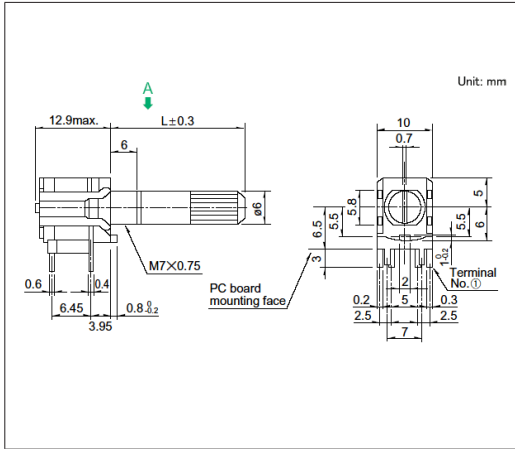

■ Mounting Hole Dimensions

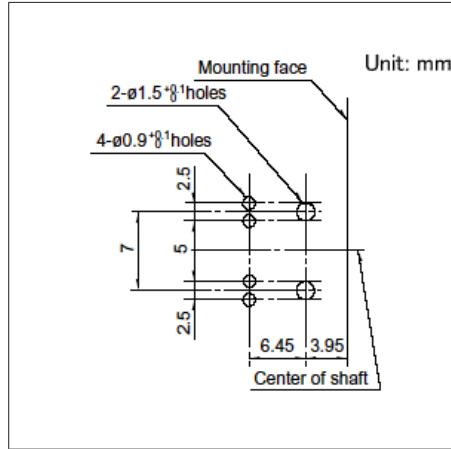

■ Circuit Diagram

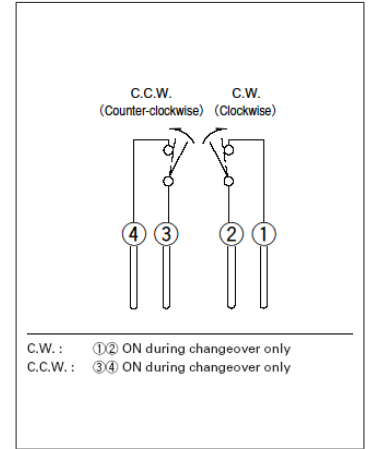

Viewed from direction A in the dimensions.

Pulse Switch

Drawing No.10

■ Dimensions

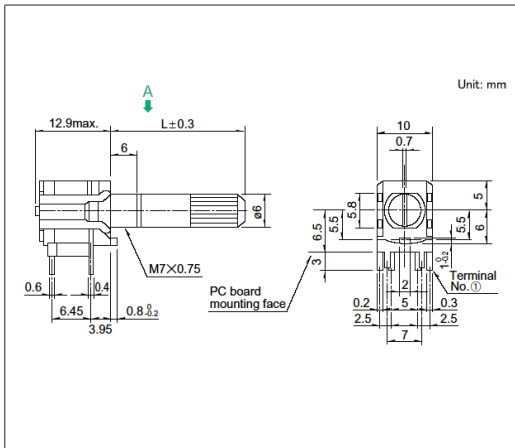

■ Mounting Hole Dimensions

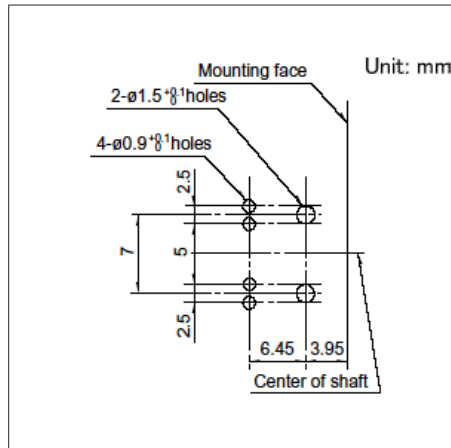

■ Circuit Diagram

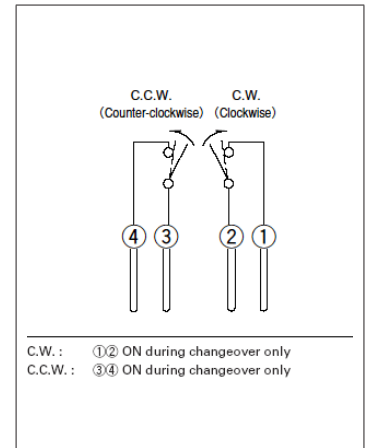

Viewed from direction A in the dimensions.

Pulse Switch

Switches Rotary Switches

8-positions Low-profile Vertical Type
SRBV Series

Contributes to set design flexibility with a body height of 7.5mm and thin-profile design.



- Rating (max.)/(min.) (Resistive load): 0.3A 16V DC/50μA 3V DC
- Contact resistance (Initial performance/After lifetime):
50mΩ max./150mΩ max.
- Operating life without load: 10,000 cycles 100mΩ max.
- Operating life with load (at max. rated load): 10,000 cycles 150mΩ max.

Applications: Home: Major home appliances

■ Product List

Products No.	Poles	Positions	Changeover angle	Changeover timing	Rotational torque	Actuator configuration	Actuator length	Dimensions (W×D×H) (mm)	Automotive	Drawing No.
SRBV131803	1	3	30±3°	Non shorting	30±15mN·m	Flat	L: 15mm	16.2×18.5×7.5	—	1
SRBV131502	1	3	30±3°	Non shorting	30±15mN·m	Flat	L: 20mm	16.2×18.5×7.5	—	2
SRBV141404	1	4	30±3°	Non shorting	30±15mN·m	Flat	L: 15mm	16.2×18.5×7.5	—	3
SRBV141201	1	4	30±3°	Non shorting	30±15mN·m	Flat	L: 20mm	16.2×18.5×7.5	—	4
SRBV151102	1	5	30±3°	Non shorting	30±15mN·m	Flat	L: 15mm	16.2×18.5×7.5	—	5
SRBV150901	1	5	30±3°	Non shorting	30±15mN·m	Flat	L: 20mm	16.2×18.5×7.5	—	6
SRBV160803	1	6	30±3°	Non shorting	30±15mN·m	Flat	L: 15mm	16.2×18.5×7.5	—	7
SRBV170701	1	7	30±3°	Non shorting	30±15mN·m	Flat	L: 15mm	16.2×18.5×7.5	—	8
SRBV170501	1	7	30±3°	Non shorting	30±15mN·m	Flat	L: 20mm	16.2×18.5×7.5	—	9
SRBV181004	1	8	30±3°	Non shorting	30±15mN·m	Flat	L: 15mm	16.2×18.5×7.5	—	10

⚠ Note

1. This catalog shows only outline specifications. When using the products, please obtain formal specifications for supply.
2. Please place purchase orders per minimum order unit (integer).

■ Packing Specifications

Tray

Number of packages(pcs.)		Export package measurements (mm)
1 case / Japan	1 case / export packing	
165	330	400 x 270 x 185

8-positions Low-profile Vertical Type
SRBV Series

Drawing No.1

■ Dimensions

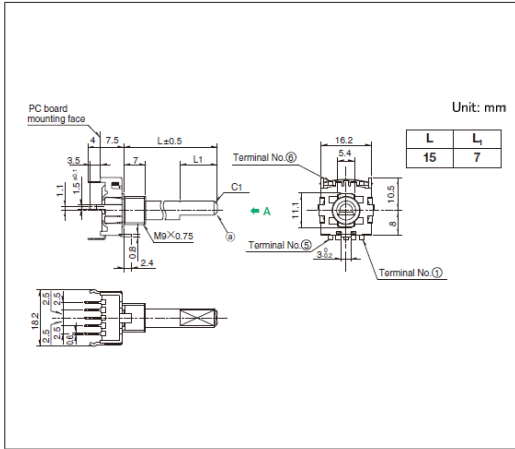

■ Mounting Hole Dimensions

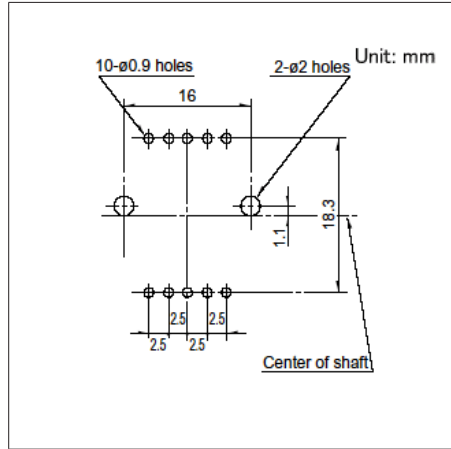

■ Circuit Diagram and Dummy Terminals

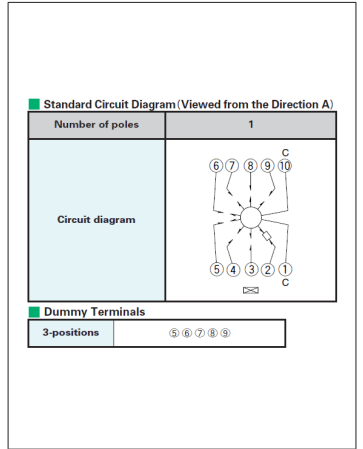

Viewed from direction A in the dimensions.

Drawing No.2

■ Dimensions

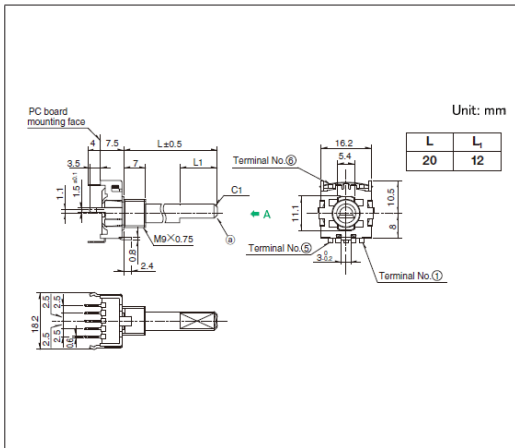

■ Mounting Hole Dimensions

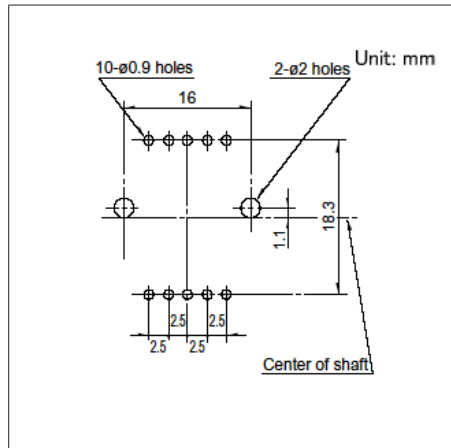

■ Circuit Diagram and Dummy Terminals

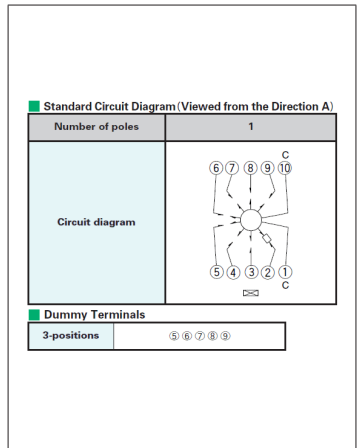

Viewed from direction A in the dimensions.

Drawing No.3

■ Dimensions

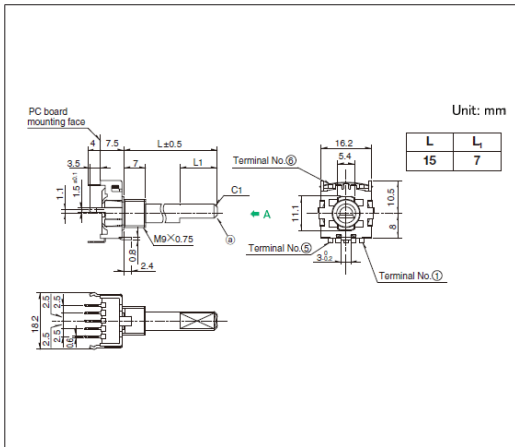

■ Mounting Hole Dimensions

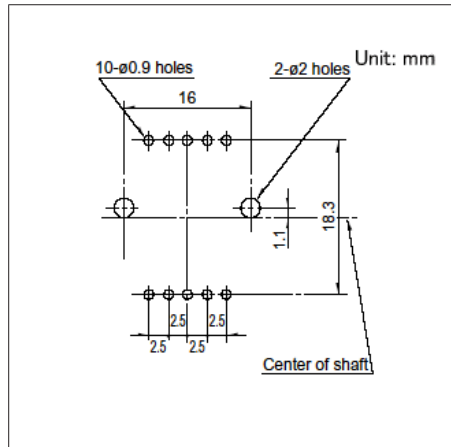

■ Circuit Diagram and Dummy Terminals

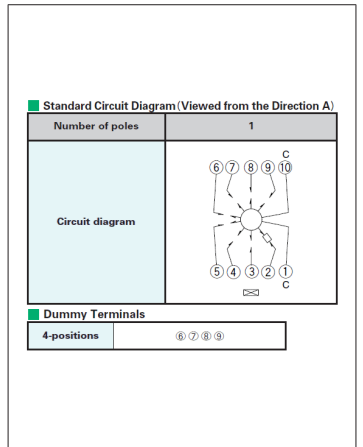

Viewed from direction A in the dimensions.

8-positions Low-profile Vertical Type
SRBV Series

Drawing No.4

■ Dimensions

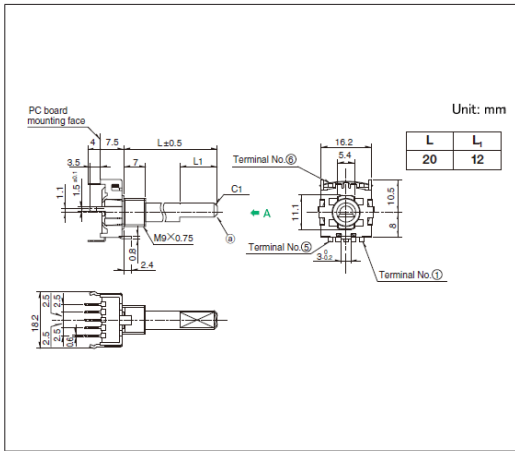

■ Mounting Hole Dimensions

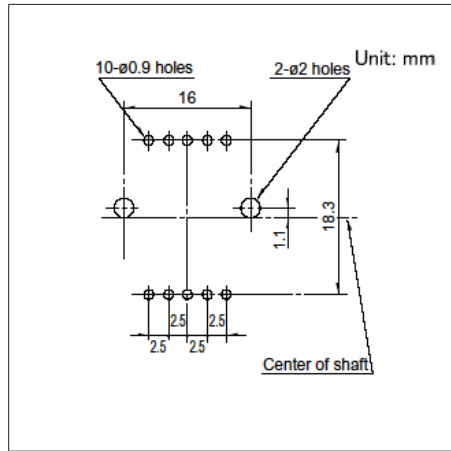

Viewed from direction A in the dimensions.

■ Circuit Diagram and Dummy Terminals

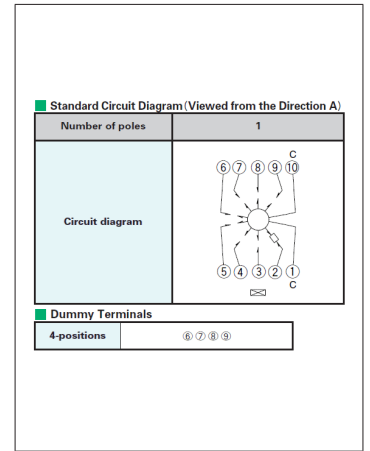

Drawing No.5

■ Dimensions

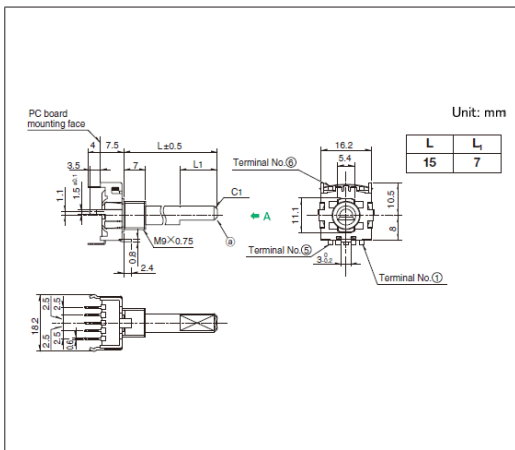

■ Mounting Hole Dimensions

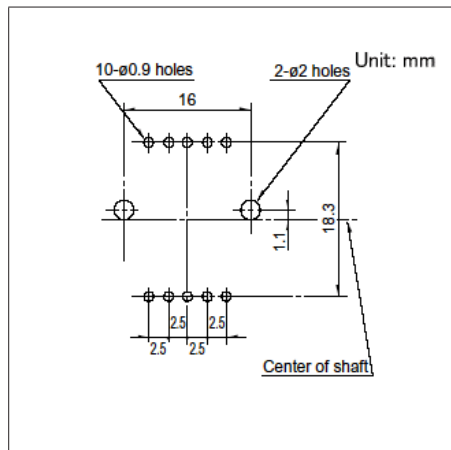

Viewed from direction A in the dimensions.

■ Circuit Diagram and Dummy Terminals

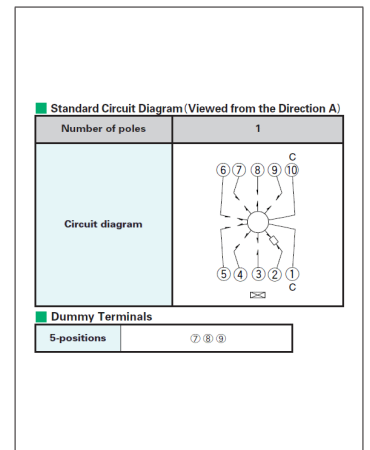

Drawing No.6

■ Dimensions

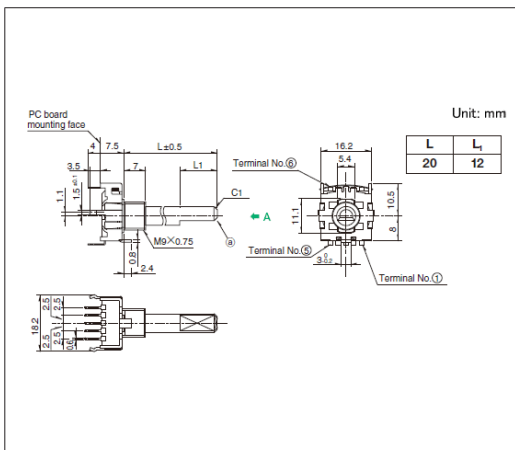

■ Mounting Hole Dimensions

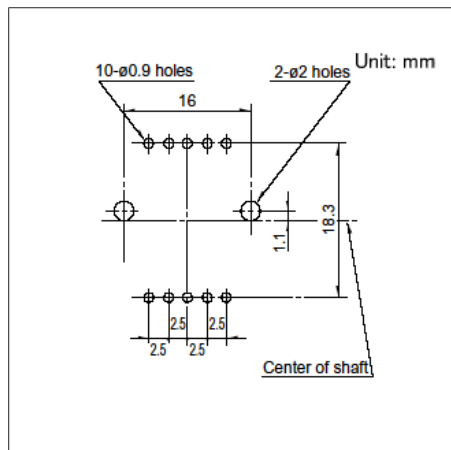

Viewed from direction A in the dimensions.

■ Circuit Diagram and Dummy Terminals

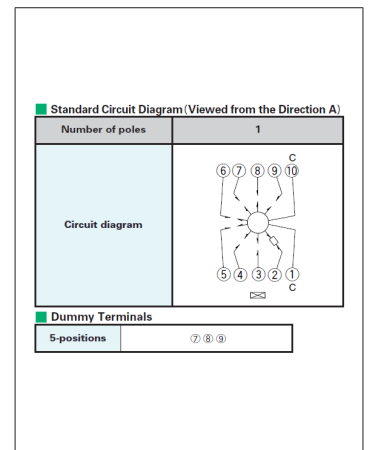

8-positions Low-profile Vertical Type
SRBV Series

Drawing No.7

■ Dimensions

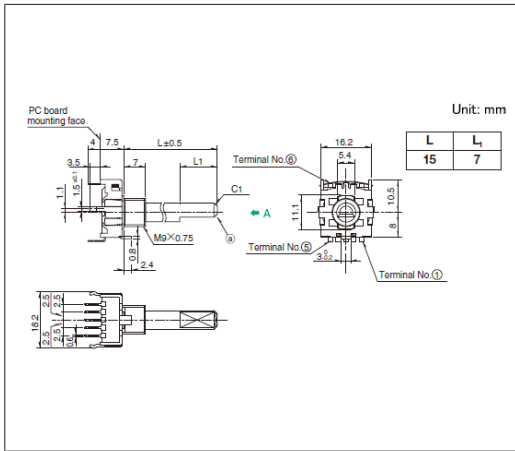

■ Mounting Hole Dimensions

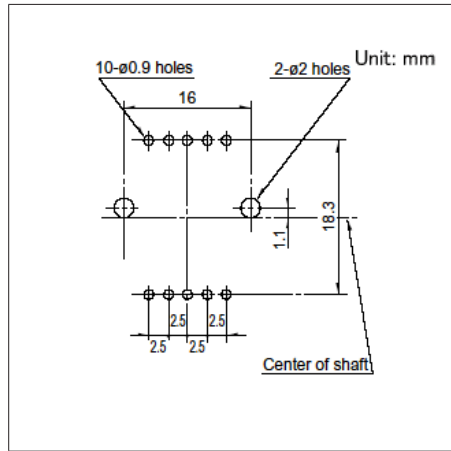

■ Circuit Diagram and Dummy Terminals

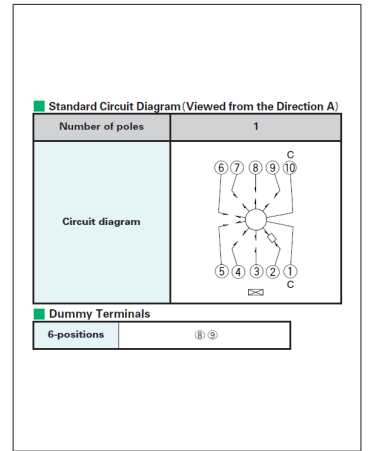

Viewed from direction A in the dimensions.

Drawing No.8

■ Dimensions

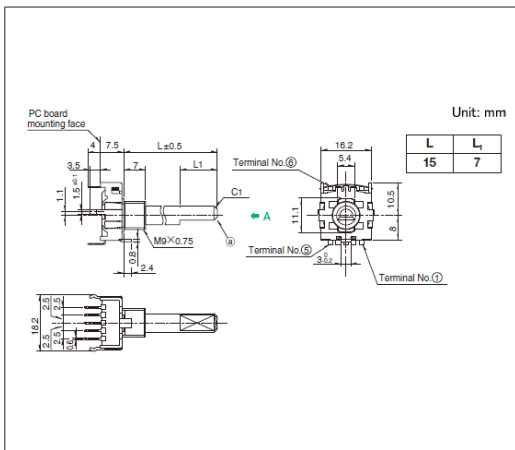

■ Mounting Hole Dimensions

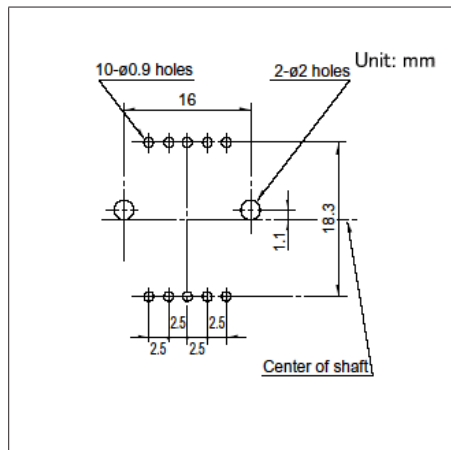

■ Circuit Diagram and Dummy Terminals

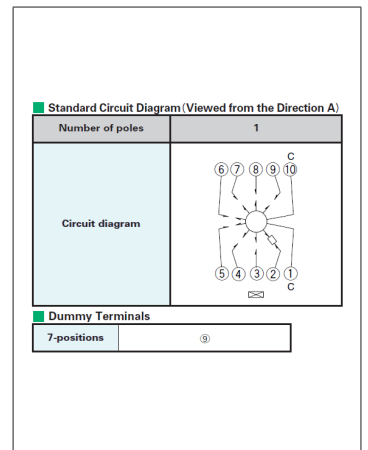

Viewed from direction A in the dimensions.

Drawing No.9

■ Dimensions

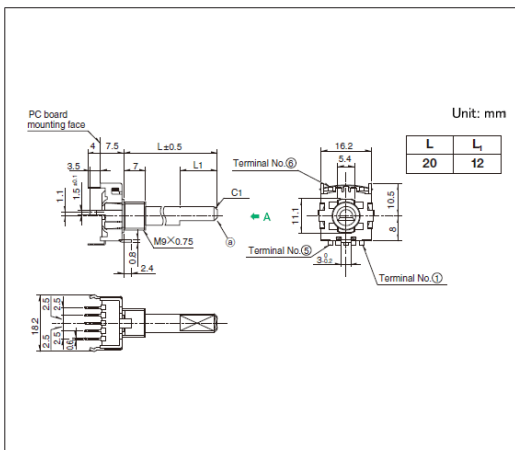

■ Mounting Hole Dimensions

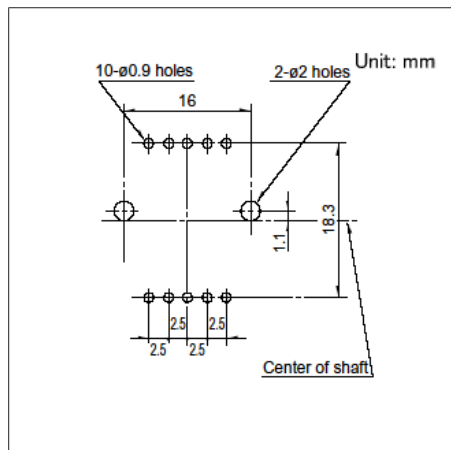

■ Circuit Diagram and Dummy Terminals

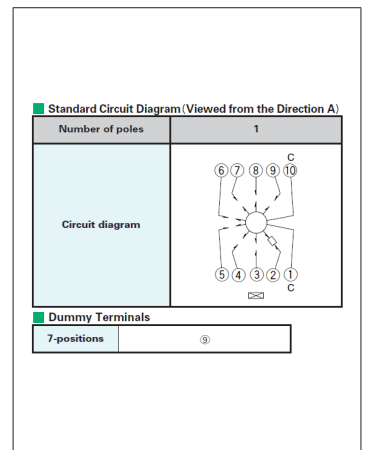

Viewed from direction A in the dimensions.

8-positions Low-profile Vertical Type
SRBV Series

Drawing No.10

■ Dimensions

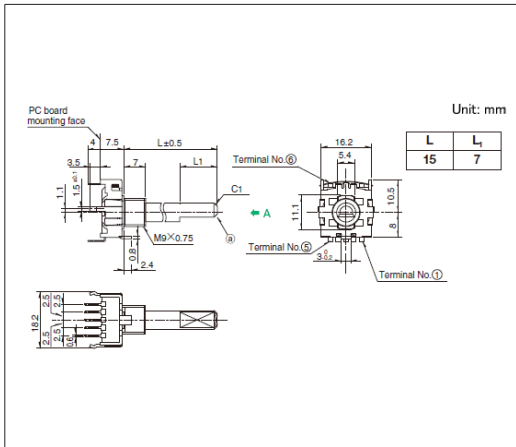

■ Mounting Hole Dimensions

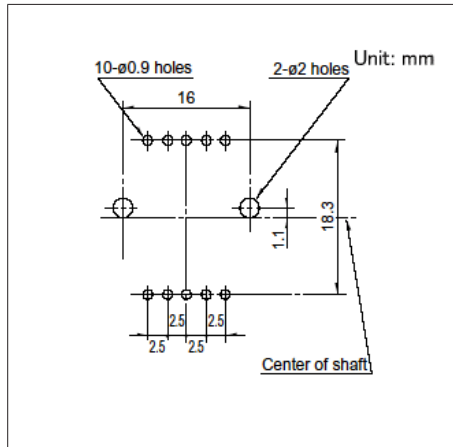

■ Circuit Diagram

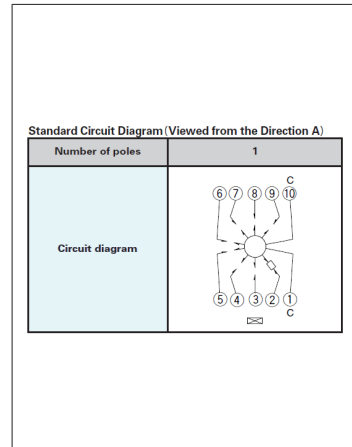

Viewed from direction A in the dimensions.

Rotary Switches / Soldering Conditions

■ Example of Reflow Soldering Condition

1. Heating method: Double heating method with infrared heater.
2. Temperature measurement: Thermocouple $\phi 0.1$ to 0.2 CA (K) or CC (T) at soldering portion (copper foil surface) .
A heat resisting tape should be used for fixed measurement.

3. Temperature profile

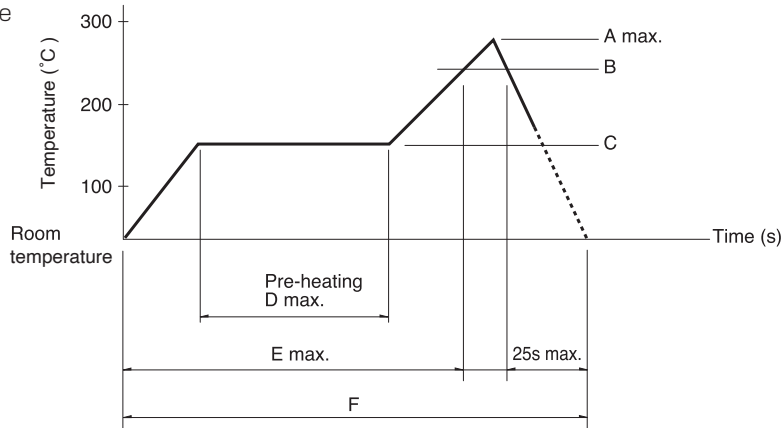

Series (Reflow type)	A (°C) 3s max.	B (°C)	C (°C)	D (s)	E (s)	F (s)
SRBQ	250	200	150±5	80 to 100	—	—

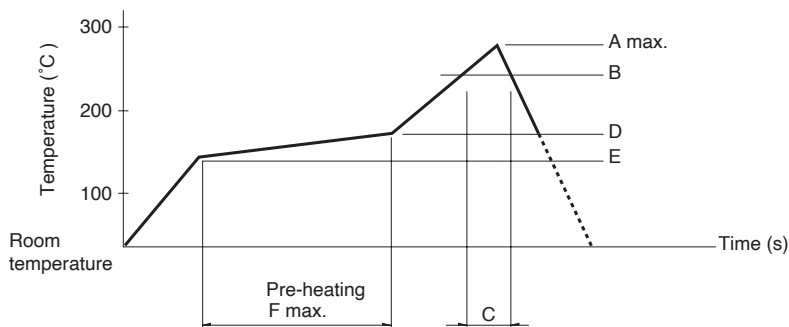

Series (Reflow type)	A (°C) 3s max.	B (°C)	C (s)	D (°C)	E (°C)	F (s)
SRBD	260	230	40	180	150	120



1. The condition mentioned above is the temperature on the mounting surface of a PC board. There are cases where the PC board's temperature greatly differs from that of the switch, depending on the PC board's material, size, thickness, etc. The above-stated conditions shall also apply to switch surface temperatures.
2. Soldering conditions differ depending on reflow soldering machines. Prior verification of soldering condition is highly recommended.

■ Reference for Hand Soldering

Series	Soldering temperature	Soldering time
SRBQ, SRBM, SRBV	350±10°C	3+1/0s
SRBQ (Reflow type)	350±5°C	3s max.

■ Reference for Dip Soldering

(For PC board terminal types)

Series	Items		Dip soldering	
	Preheating temperature	Preheating time	Soldering temperature	Duration of immersion
SRBM	100°C max.	60s max.	260±5°C	5s max.
SRBV	—	—	260±5°C	10±1s
SRBQ	—	—	260±5°C	5±1s

Rotary Switches / Cautions

1. Applying load to terminals during soldering under certain conditions may cause deformation and electrical property degradation.
2. Avoid use of water-soluble soldering flux, since it may corrode the switches.
3. Check and conform to soldering requirements under actual mass production conditions.
4. When soldering twice, wait until the first soldered portion cools to normal temperature. Continuous heating will deform the external portions, loosen or dislodge terminals, or may deteriorate their electrical characteristics.
5. Flux from around and above the PC board should not adhere to the switches.
6. After mounting the switches, if you intend to put the board into an oven in order to harden adhesive for other parts, please consult with us.
7. If you use a through-hole PC board or a PC board thinner or thicker than the recommendation, there may be greater heat stress. Verify the soldering conditions thoroughly before use.
8. Solder the switches with detent at the detent position. Soldering switches fixed at the center of the detent may deform the detent mechanisms.
9. No cleaning.
10. Protect small and thin switches from external forces in the set mounting process.
11. Tighten the mounting screws by applying the specified torque. Tightening with larger torque than the specified one will result in malfunction or breakage of screws.
12. Insert these switches to the specified mounting surface and mount them horizontally. If not mounted horizontally, these switches will malfunction.
13. The products are designed and manufactured for direct current resistance. Contact us for use of other resistances such as inductive (L) or capacitive (C).
14. The switch will break if you apply a greater stress than that specified. Take great care not to let the switch be subject to greater stress than specified.
15. Use of the switches in a dusty environment may lead to dusts entering through the openings and cause imperfect contact or malfunction. Take this into account for set design.
16. Corrosive gas if generated by peripheral parts of a set, malfunction such as imperfect contact may occur. Thorough investigation shall be required beforehand.
17. Storage
Store the products as delivered at normal temperature and humidity, out of direct sunlight and away from corrosive gases. Use them as soon as possible and no later than six months after delivery.
Once the seal is broken, use them as soon as possible.





Encoders

- Metal shaft Encoder ————— 338
- Insulated shaft Encoder ————— 347
- Through shaft Encoder ————— 356
- Ring Encoder ————— 362

Encoders

Metal shaft Encoder

List of Varieties

Series		EC09E	EC111	EC11E	EC11M
Photo					
Dimensions		9mm size	11mm size		
Output		Incremental (Two phase A and B)	Self-return switch	Incremental (Two phase A and B)	
Actuator configuration		Flat			Serrated
Number of detent		30	Without	18 30 36	30 Without
Number of pulse		15	Self-return switch	9 15 18	15
Operating temperature range		-40°C to +85°C			
Operating life		15,000 cycles			
Electrical performance	Ratings	10mA 5V DC			
	Max./min. operating current (Resistive load)	10mA/1mA			
	Insulation resistance	100MΩ min. 250V DC			
	Voltage proof	300V AC for 1 minute or 360V AC for 1s	300V AC for 1 minute or 360V AC for 2s		
Mechanical performance	Rotational torque	—	3 ~ 30mN·m	—	8.5±5mN·m
	Detent torque	8±5mN·m	—	10±7mN·m	12±7mN·m
	Push-pull strength	100N			
Push-on switch specifications	Contact arrangement	Single pole single throw (Push-on)			
	Travel (mm)	0.5±0.3 1.5±0.5			1.5±0.35
	Operating force (N)	4±2 6(+2.5, -2)			5±2
	Rating	10mA 5V DC (1mA 5V DC min. ratings)	0.1A 5V DC (500μA 5V DC min. ratings)		
	Contact resistance (Initial performance/ After lifetime)	100mΩ max./200mΩ max.			
	Operating life (times)	10,000	20,000		
Automotive		●	●	●	●

 Note

● Indicates applicability to all products in the series, while ○ indicates applicability to some products in the series.

Encoders Metal shaft Encoder

9mm Size Metal Shaft Type EC09E Series

Compact, round type with a 9.5mm body size, contributing to reduced mounting area.



Automotive

- Output signal: Two phase A and B
- Ratings: 10mA 5V DC
- Operating life: 15,000 cycles

Applications: Automotive: Navigation/audio systems, HVAC

Product List

Products No.	Control part orientation	Actuator configuration	Actuator length (mm)	Detent torque	Number of detent	Number of pulse	Push-on switch	Travel of push-on switch (mm)	Automotive	Drawing No.
EC09E1520407	Vertical	Flat	15	8±5mN·m	30	15	Without	—	●	1
EC09E1524417	Vertical	Flat	20	8±5mN·m	30	15	With	0.5	●	2
EC09E1524418	Vertical	Flat	20	8±5mN·m	30	15	With	1.5	●	3

Note

1. This catalog shows only outline specifications. When using the products, please obtain formal specifications for supply.
2. Please place purchase orders per minimum order unit (integer).
3. Products other than those listed in the above chart are also available. Please contact us for details.

Packing Specifications

Tray

Number of packages (pcs.)		Export package measurements (mm)
1 case / Japan	1 case / export packing	
700	1,400	529 x 374 x 213

Drawing No. 1

Dimensions

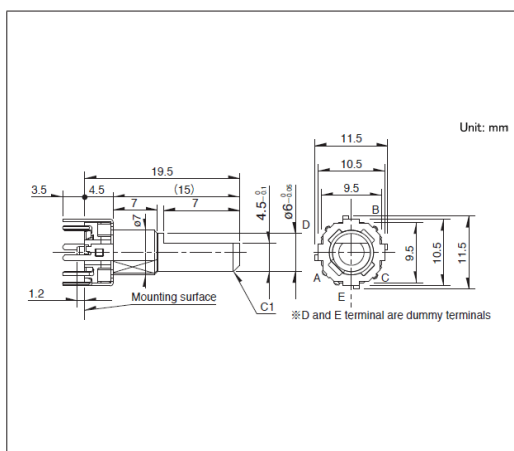

Mounting Hole Dimensions

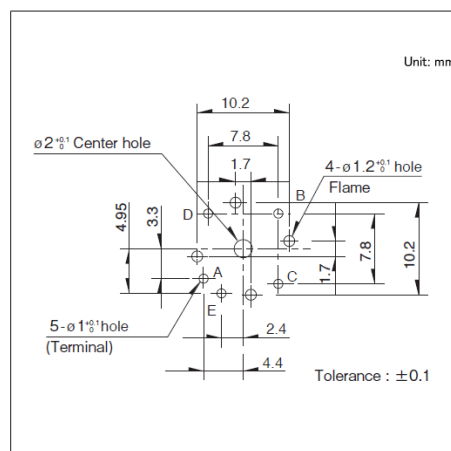

Viewed from mounting side.

9mm Size Metal Shaft Type
EC09E Series

Drawing No.2

■ Dimensions

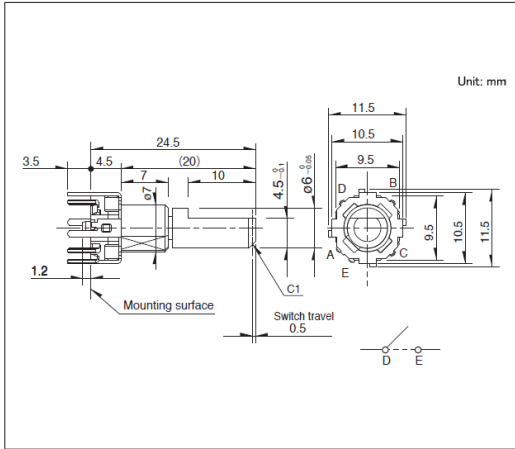

■ Mounting Hole Dimensions

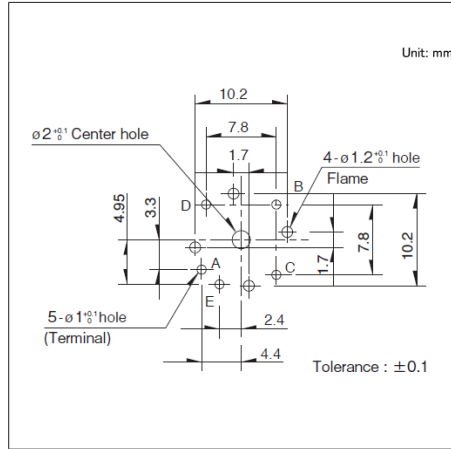

Viewed from mounting side.

Drawing No.3

■ Dimensions

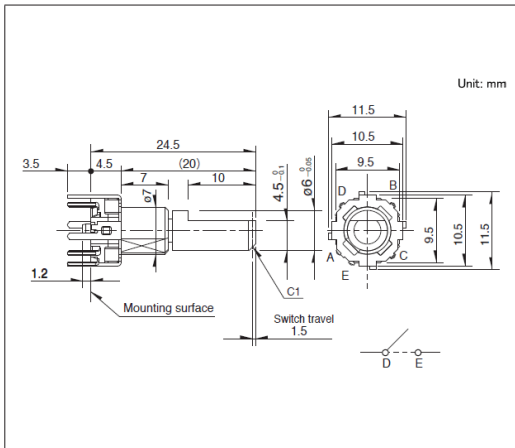

■ Mounting Hole Dimensions

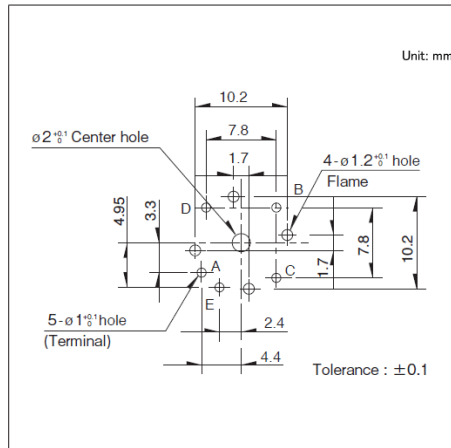

Viewed from mounting side.

Encoders Metal shaft Encoder

11mm Size Metal Shaft Type
EC111 Series

Compact and highly reliable with a diverse product variety.

 Automotive



- Output signal: Self-return switch
- Ratings: 10mA 5V DC
- Operating life: 15,000 cycles

Applications: Energy_Industrial: Industrial equipment, Converters
Home: Major home appliances
Audio_TV: Visual, Audio
Automotive: Navigation/audio systems, HVAC

■ Product List

Products No.	Control part orientation	Actuator configuration	Actuator length (mm)	Rotational torque	Number of detent	Number of pulse	Push-on switch	Travel of push-on switch (mm)	Automotive	Drawing No.
EC1110120005	Vertical	Flat	15	3 ~ 30mN·m	Without	Self-return switch	Without	—	●	1
EC111012010H	Vertical	Flat	20	3 ~ 30mN·m	Without	Self-return switch	With	0.5	●	2
EC1110120201	Vertical	Flat	20	3 ~ 30mN·m	Without	Self-return switch	With	1.5	●	

 Note

1. This catalog shows only outline specifications. When using the products, please obtain formal specifications for supply.
2. Please place purchase orders per minimum order unit (integer).
3. Products other than those listed in the above chart are also available. Please contact us for details.

■ Packing Specifications

Tray

Number of packages (pcs.)		Export package measurements (mm)
1 case / Japan	1 case / export packing	
1,200	2,400	507 x 363 x 216

Drawing No.1

■ Dimensions

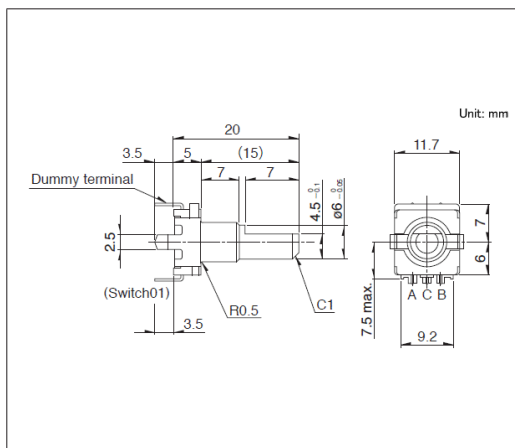

■ Mounting Hole Dimensions

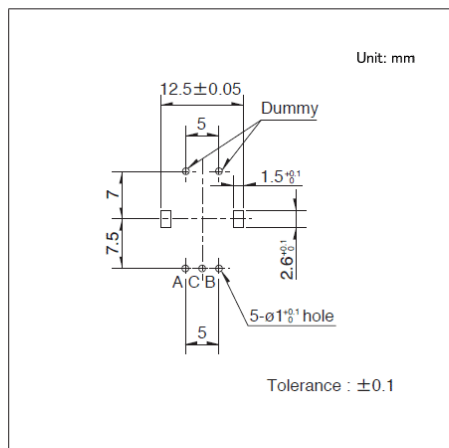

■ Circuit Diagram

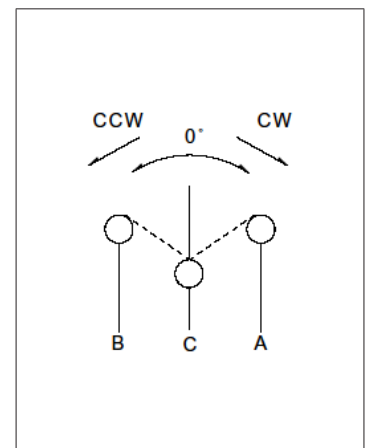

Viewed from mounting side.

11 mm Size Metal Shaft Type
EC111 Series

Drawing No.2

■ Dimensions

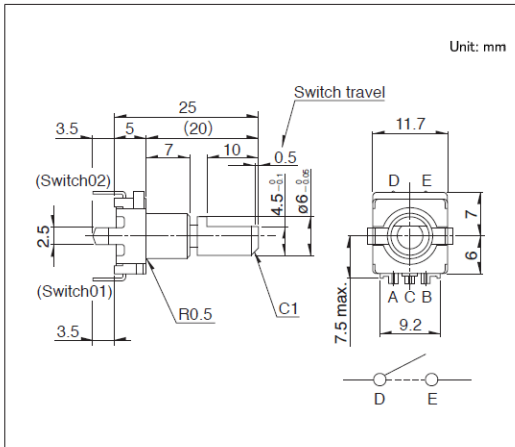

■ Mounting Hole Dimensions

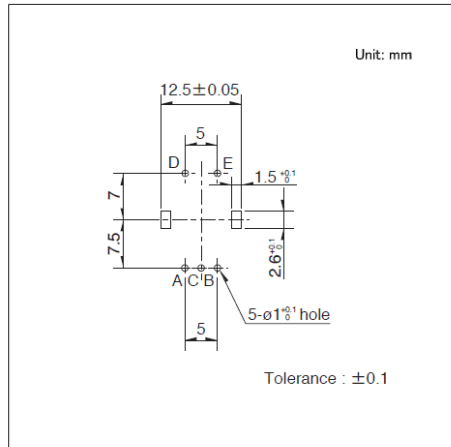

■ Circuit Diagram

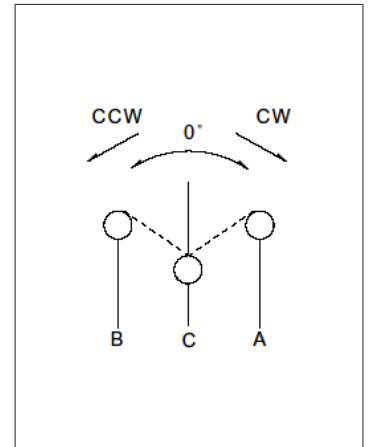

Viewed from mounting side.

Encoders

Metal shaft Encoder

11mm Size Metal Shaft Type
EC11E Series

Compact and highly reliable with a diverse product variety.

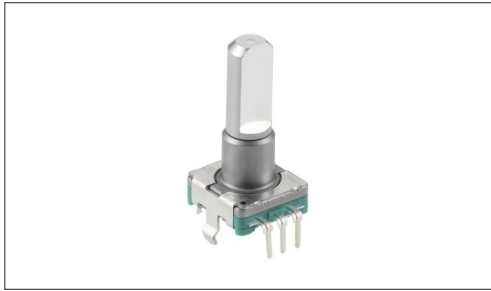
 Automotive

- Output signal: Two phase A and B
- Ratings: 10mA 5V DC
- Operating life: 15,000 cycles

Applications: Energy_Industrial: Industrial equipment, Converters
 Home: Major home appliances
 Audio_TV: Visual, Audio
 Automotive: Navigation/audio systems, HVAC

■ Product List

Products No.	Control part orientation	Actuator configuration	Actuator length (mm)	Detent torque	Number of detent	Number of pulse	Push-on switch	Travel of push-on switch (mm)	Automotive	Drawing No.
EC11E09204A4	Vertical	Flat	20	10±7mN·m	18	9	Without	—	●	1
EC11E15204A3	Vertical	Flat	20	10±7mN·m	30	15	Without	—	●	
EC11E1820402	Vertical	Flat	20	10±7mN·m	36	18	Without	—	●	
EC11E09244BS	Vertical	Flat	20	10±7mN·m	18	9	With	0.5	●	2
EC11E15244G1	Vertical	Flat	20	10±7mN·m	30	15	With	0.5	●	
EC11E18244AU	Vertical	Flat	20	10±7mN·m	36	18	With	0.5	●	
EC11E09244AQ	Vertical	Flat	20	10±7mN·m	18	9	With	1.5	●	3
EC11E15244B2	Vertical	Flat	20	10±7mN·m	30	15	With	1.5	●	
EC11E18244A5	Vertical	Flat	20	10±7mN·m	36	18	With	1.5	●	

 Note

1. This catalog shows only outline specifications. When using the products, please obtain formal specifications for supply.
2. Please place purchase orders per minimum order unit (integer).
3. Products other than those listed in the above chart are also available. Please contact us for details.

■ Packing Specifications

Tray

Number of packages(pcs.)		Export package measurements (mm)
1 case / Japan	1 case / export packing	
1,200	2,400	540 x 360 x 250

11 mm Size Metal Shaft Type
EC11E Series

Drawing No.1

■ Dimensions

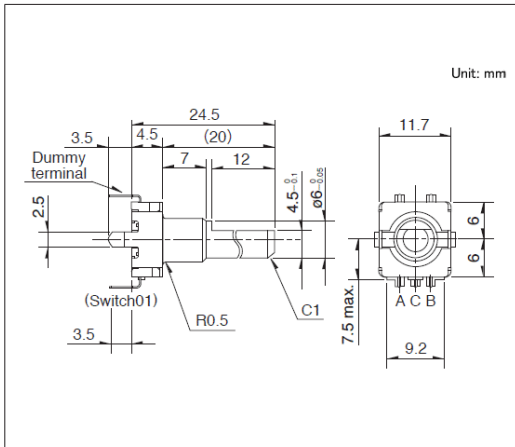

■ Mounting Hole Dimensions

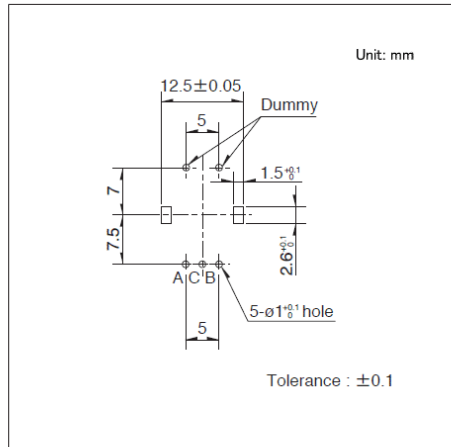

Viewed from mounting side.

Drawing No.2

■ Dimensions

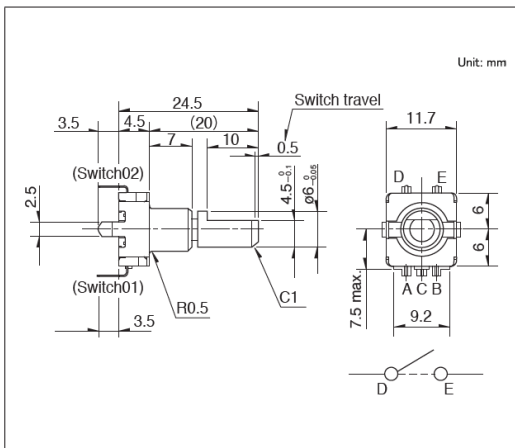

■ Mounting Hole Dimensions

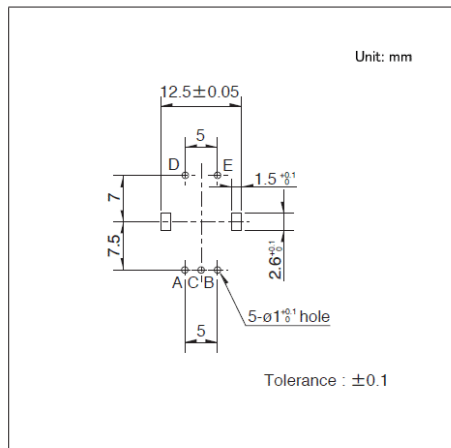

Viewed from mounting side.

Drawing No.3

■ Dimensions

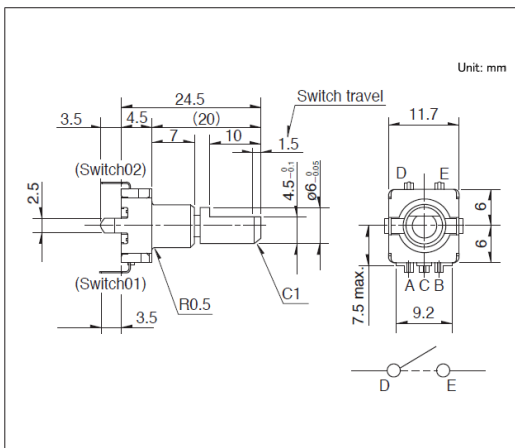

■ Mounting Hole Dimensions

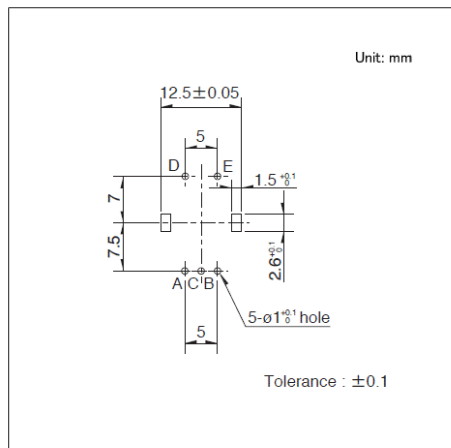

Viewed from mounting side.

Encoders Metal shaft Encoder

11mm Size Metal Shaft Type
EC11M Series

Compact and highly reliable with a diverse product variety.

 Automotive



- Output signal: Two phase A and B
- Ratings: 10mA 5V DC
- Operating life: 15,000 cycles

Applications: Energy_Industrial: Industrial equipment, Converters
Home: Major home appliances
Audio_TV: Visual, Audio
Automotive: Navigation/audio systems, HVAC

■ Product List

Products No.	Control part orientation	Actuator configuration	Actuator length (mm)	Rotational torque	Detent torque	Number of detent	Number of pulse	Push-on switch	Travel of push-on switch (mm)	Automotive	Drawing No.
EC11M1565403	Vertical	Serrated	25	—	12±7mN·m	30	15	With	1.5	●	1
EC11M1575403	Vertical	Serrated	25	8.5±5mN·m	—	Without	15	With	1.5	●	2

 Note

1. This catalog shows only outline specifications. When using the products, please obtain formal specifications for supply.
2. Please place purchase orders per minimum order unit (integer).
3. Products other than those listed in the above chart are also available. Please contact us for details.

■ Packing Specifications

Tray

Number of packages (pcs.)		Export package measurements (mm)
1 case / Japan	1 case / export packing	
1,000	2,000	540 x 360 x 250

Drawing No.1

■ Dimensions

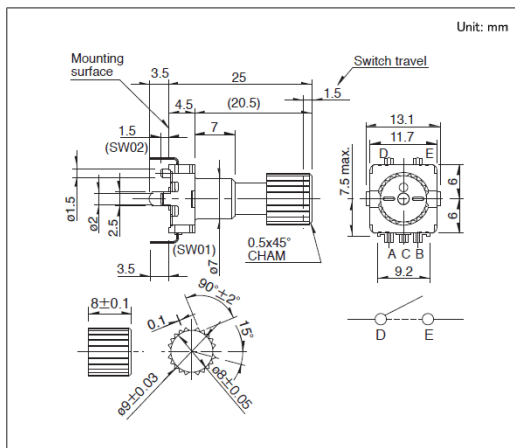

■ Mounting Hole Dimensions

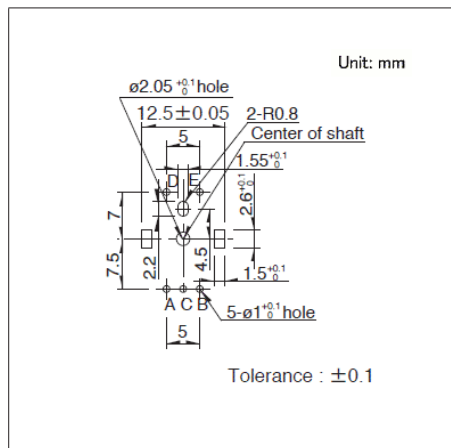

Viewed from mounting side.

11 mm Size Metal Shaft Type
EC11M Series

Drawing No.2

■ Dimensions

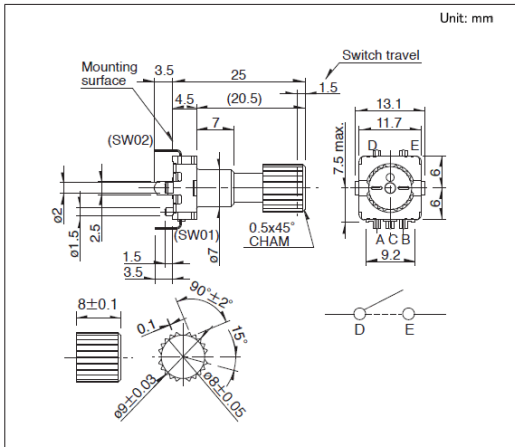

■ Mounting Hole Dimensions

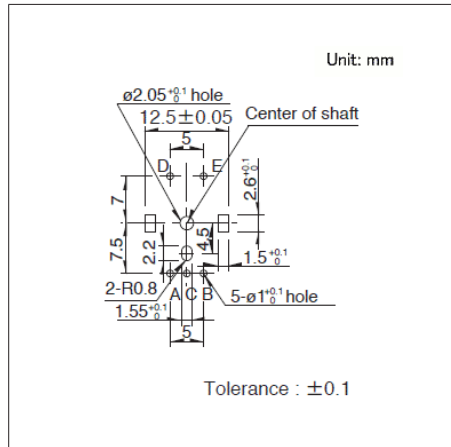



Viewed from mounting side.

Encoders

Insulated shaft Encoder

List of Varieties

Series		EC12E	EC12D	EC18A
Photo				
Dimensions		12mm size		18mm size
Output		Incremental (Two phase A and B)		Absolute
Water-proof		—	—	●
Dust-proof		—	—	—
IP standard		—	—	IPX7 equivalent
Actuator configuration		—	—	Flat
Number of detent		12 24 Without	30	—
Detent torque		12 24	15	—
Operating temperature range		-10°C to +70°C	-40°C to +85°C	-20°C to +60°C
Operating life		30,000 cycles		
Electrical performance	Ratings	0.5mA 5V DC	1mA 5V DC	1mA 10V DC
	Max./min. operating current (Resistive load)	5mA/0.5mA	10mA/1mA	—
	Insulation resistance	10MΩ min. 50V DC	100MΩ min. 250V DC	10MΩ min. 250V DC
	Voltage proof	50V AC for 1 minute	300V AC for 1 minute or 360V AC for 1s	50V AC for 1 minute or 60V AC for 2s
Mechanical performance	Rotational torque	10mN·m max. 40±15mN·m	—	—
	Detent torque	3 to 20mN·m 3±2mN·m	10±5mN·m 5±3mN·m	—
	Push-pull strength	80N	100N	Push 100N / Pull 50N
Push-on switch specifications	Contact arrangement	—	Single pole single throw (Push-on)	—
	Travel (mm)	—	0.5±0.3	—
	Operating force (N)	—	3(+1.5, -1) 6(+2.5, -2)	—
	Rating	—	1mA 5V DC (10mA 5V DC max. ratings)	—
	Contact resistance (Initial performance/ After lifetime)	—	100mΩ max./200mΩ max.	—
	Operating life (times)	—	30,000	—
Automotive		—	●	—

 Note

● Indicates applicability to all products in the series, while ○ indicates applicability to some products in the series.

12mm Size Insulated Shaft Type EC12E Series

Insulated shaft type with a diverse product variety.

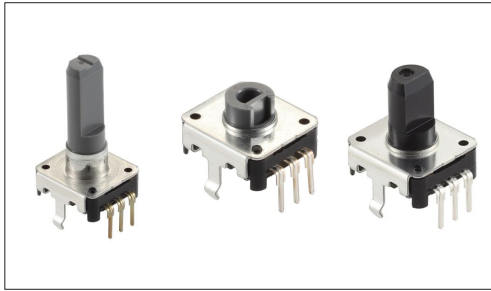

- Output signal: Two phase A and B
- Ratings: 0.5mA 5V DC
- Operating life: 30,000 cycles

Applications: Energy_Industrial: Converters
Home: Major home appliances
Audio_TV: Visual, Audio, Pro audio

■ Product List

Products No.	Type	Actuator length (mm)	Torque	Number of detent	Number of pulse	Automotive	Drawing No.	
EC12E1220407	Standard Type	15.0	Standard 3 to 20mN·m	12	12	—	1	
EC12E1220406		20.0	Standard 3 to 20mN·m	12	12	—	2	
EC12E1220405		25.0	Standard 3 to 20mN·m	12	12	—	3	
EC12E1220301		8.5 (Hollow shaft)	Standard 3 to 20mN·m	12	12	—	4	
EC12E1240405		20.0	Lightest (jog) 3±2mN·m	12	12	—	2	
EC12E1240406		25.0	Lightest (jog) 3±2mN·m	12	12	—	3	
EC12E1240301		8.5 (Hollow shaft)	Lightest (jog) 3±2mN·m	12	12	—	4	
EC12E24204A2		15.0	Standard 3 to 20mN·m	24	24	—	1	
EC12E24204A7		17.5	Standard 3 to 20mN·m	24	24	—	5	
EC12E24204A8		20.0	Standard 3 to 20mN·m	24	24	—	2	
EC12E24204A9		25.0	Standard 3 to 20mN·m	24	24	—	3	
EC12E2420301		8.5 (Hollow shaft)	Standard 3 to 20mN·m	24	24	—	4	
EC12E24404A8		20.0	Lightest (jog) 3±2mN·m	24	24	—	2	
EC12E24404A6		25.0	Lightest (jog) 3±2mN·m	24	24	—	3	
EC12E2440301		8.5 (Hollow shaft)	Lightest (jog) 3±2mN·m	24	24	—	4	
EC12E24104A6		20.0	Lightest (jog) 10mN·m max	Without	24	—	2	
EC12E1220813		With Bushing Type	25.0	Standard 3 to 20mN·m	12	12	—	6
EC12E2420802			20.0	Standard 3 to 20mN·m	24	24	—	7
EC12E2420801	25.0		Standard 3 to 20mN·m	24	24	—	6	
EC12E2420803	30.0		Standard 3 to 20mN·m	24	24	—	8	
EC12E2460802	30.0		Heavy 40±15mN·m	Without	24	—		

⚠ Note

1. This catalog shows only outline specifications. When using the products, please obtain formal specifications for supply.
2. Please place purchase orders per minimum order unit (integer).
3. Products other than those listed in the above chart are also available. Please contact us for details.
4. Nuts and washers are not included. If required, please contact us.

12mm Size Insulated Shaft Type
EC12E Series

■ Packing Specifications

Tray

Products No.	Number of packages (pcs.)		Export package measurements (mm)
	1 case / Japan	1 case / export packing	
EC12E1220407 EC12E1220406 EC12E1220405 EC12E1240405 EC12E1240406 EC12E24204A2 EC12E24204A7 EC12E24204A8 EC12E24204A9 EC12E24404A8 EC12E24404A6 EC12E24104A6	2,400	2,400	525 x 369 x 204
EC12E1220301 EC12E1240301 EC12E2420301 EC12E2440301	3,000	3,000	525 x 369 x 204
EC12E1220813 EC12E2420802 EC12E2420801 EC12E2420803 EC12E2460802	1,900	1,900	525 x 369 x 204

Drawing No.1

■ Dimensions

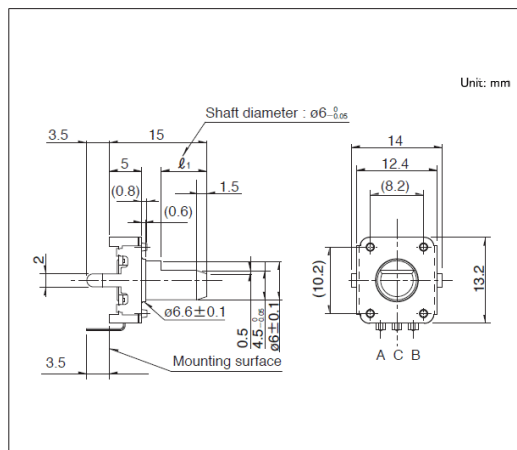

■ Mounting Hole Dimensions

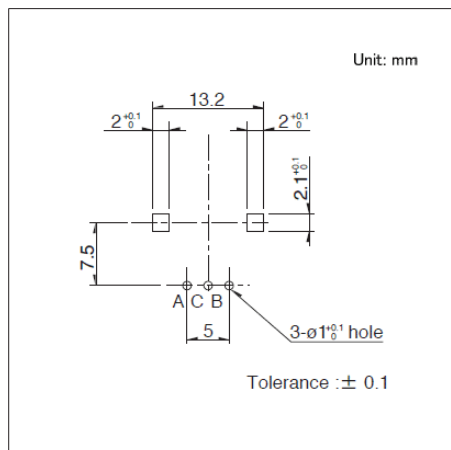

Viewed from mounting face.

Drawing No.2

■ Dimensions

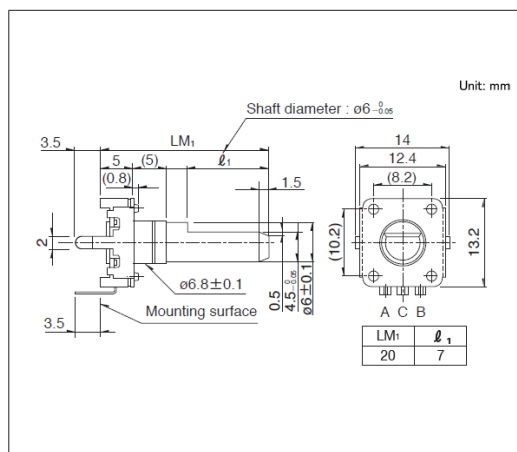

■ Mounting Hole Dimensions

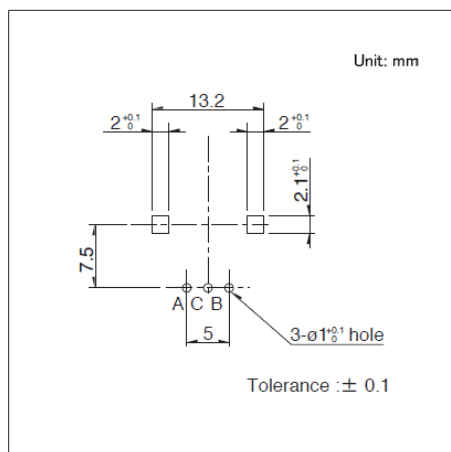

Viewed from mounting face.

12mm Size Insulated Shaft Type
EC12E Series

Drawing No.3

■ Dimensions

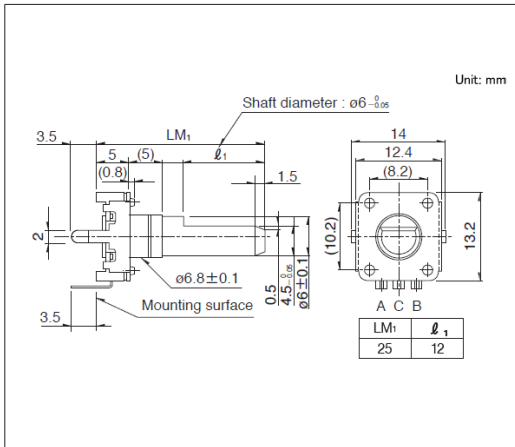

■ Mounting Hole Dimensions

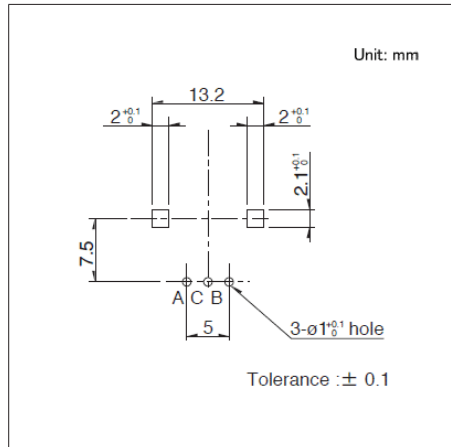

Viewed from mounting face.

Drawing No.4

■ Dimensions

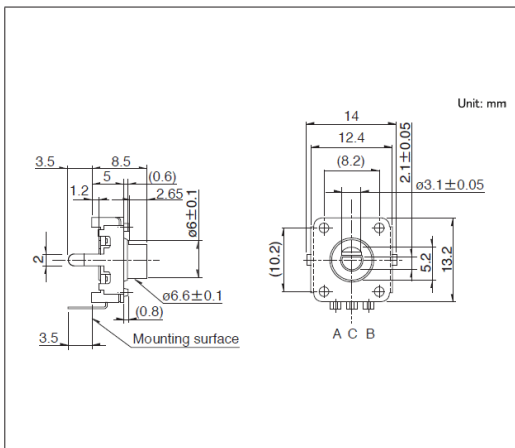

■ Mounting Hole Dimensions

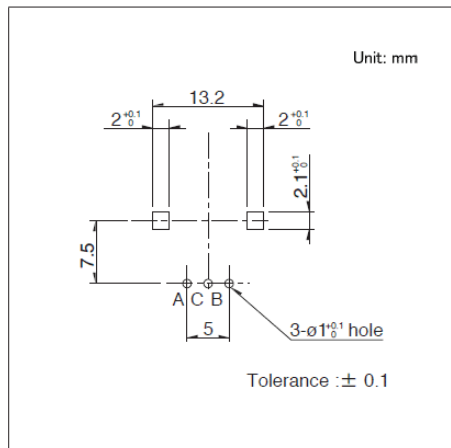

Viewed from mounting face.

Drawing No.5

■ Dimensions

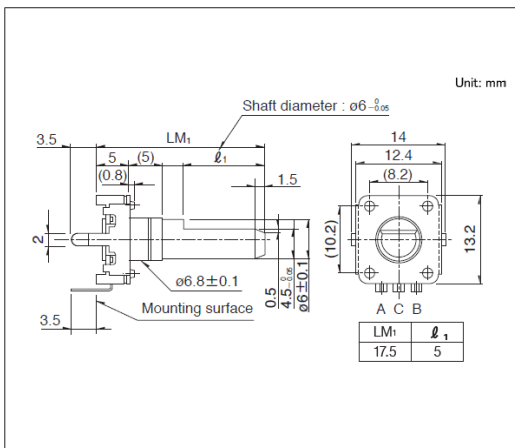

■ Mounting Hole Dimensions

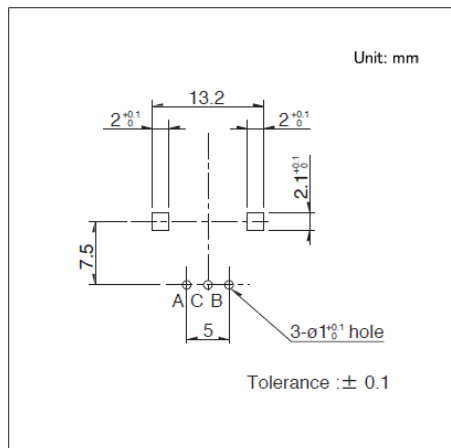

Viewed from mounting face.

12mm Size Insulated Shaft Type
EC12E Series

Drawing No.6

■ Dimensions

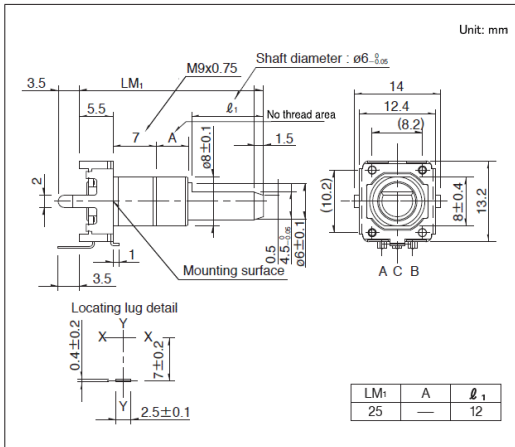

■ Mounting Hole Dimensions

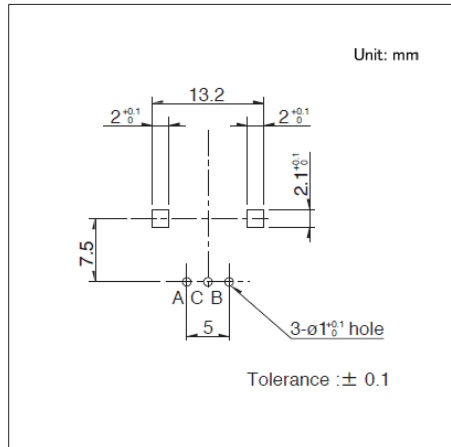

Viewed from mounting face.

Drawing No.7

■ Dimensions

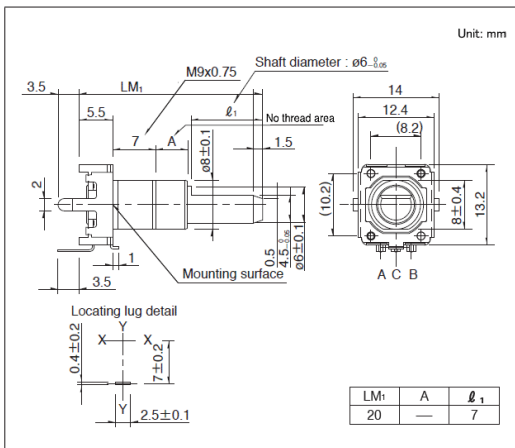

■ Mounting Hole Dimensions

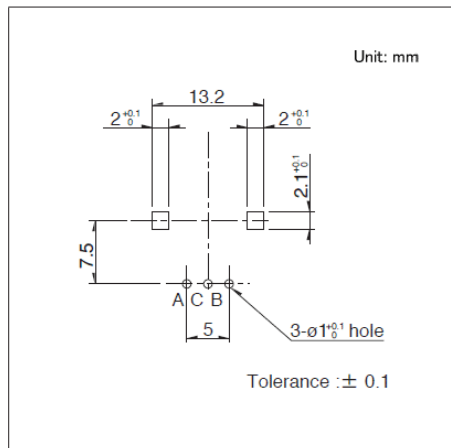

Viewed from mounting face.

Drawing No.8

■ Dimensions

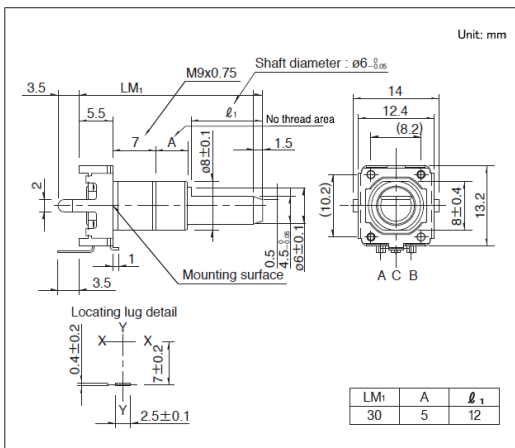

■ Mounting Hole Dimensions

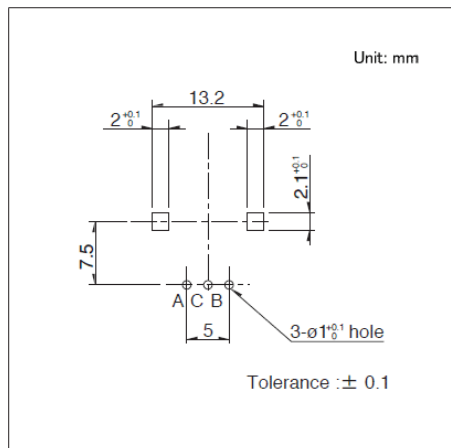

Viewed from mounting face.

Encoders Insulated shaft Encoder

12mm Size Insulated Shaft Type
EC12D Series

Automotive-compatible with push-on feature.

 Automotive



- Output signal: Two phase A and B
- Ratings: 1 mA 5V DC
- Operating life: 30,000 cycles

Applications: Energy_Industrial: Converters
 Home: Major home appliances
 Audio_TV: Visual, Audio, Pro audio
 Automotive: Navigation/audio systems, HVAC

■ Product List

Products No.	Type	Actuator length (mm)	Detent torque	Number of detent	Number of pulse	Automotive	Drawing No.
EC12D1524403	With Switch Type	17.5	5±3mN·m	30	15	●	1
EC12D1564402		17.5	10±5mN·m	30	15	●	
EC12D1524406		17.5	5±3mN·m	30	15	●	
EC12D1564404		17.5	10±5mN·m	30	15	●	

 Note

1. This catalog shows only outline specifications. When using the products, please obtain formal specifications for supply.
2. Please place purchase orders per minimum order unit (integer).
3. Products other than those listed in the above chart are also available. Please contact us for details.

■ Packing Specifications

Tray

Number of packages(pcs.)		Export package measurements (mm)
1 case / Japan	1 case / export packing	
1,280	2,560	540 x 360 x 290

Drawing No.1

■ Dimensions

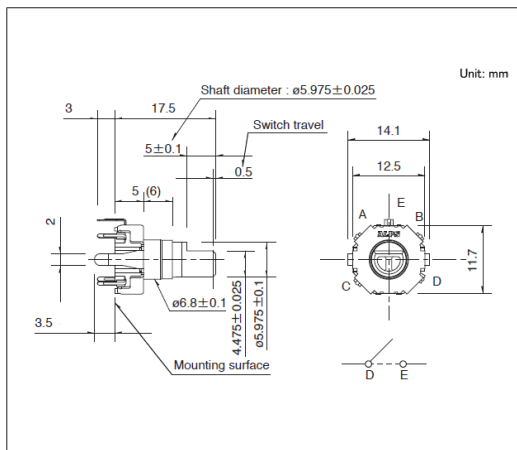

■ Mounting Hole Dimensions

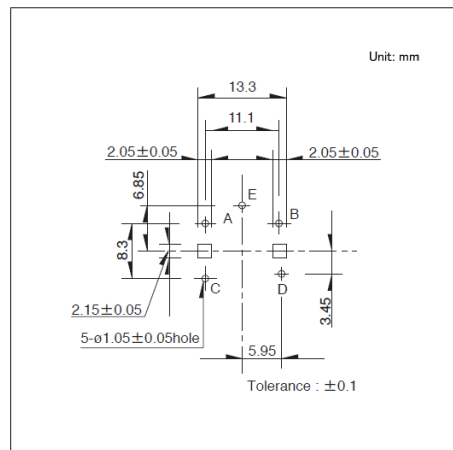

Viewed from mounting face.

Encoders Insulated shaft Encoder

18mm Size Insulated Shaft Type
EC18A Series

Absolute type with high water resistance and heavy torque.



- Ratings: 1 mA 10V DC
- Operating life: 30,000 cycles

Applications: Home: Major home appliances

■ Product List

Products No.	Actuator length (mm)	Detent torque	Positions	Automotive	Drawing No.
EC18AGA20402	30.72	60±20mN·m	12	—	1
EC18AGB20407	32.56	60±20mN·m	15	—	2
EC18AGB20401	38.06	60±20mN·m	16	—	3

Note

1. This catalog shows only outline specifications. When using the products, please obtain formal specifications for supply.
2. Please place purchase orders per minimum order unit (integer).

■ Packing Specifications

Tray

Number of packages (pcs.)		Export package measurements (mm)
1 case / Japan	1 case / export packing	
450	900	540 x 360 x 270

Drawing No.1

■ Dimensions

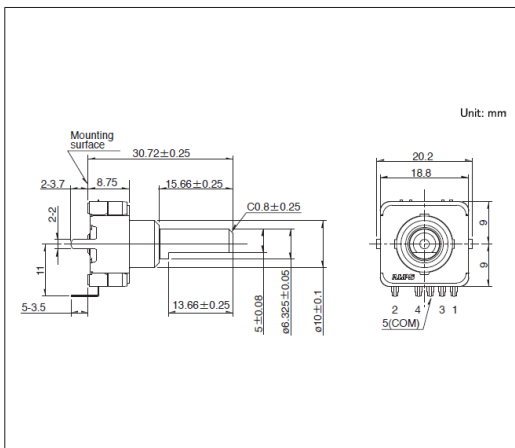

■ Mounting Hole Dimensions

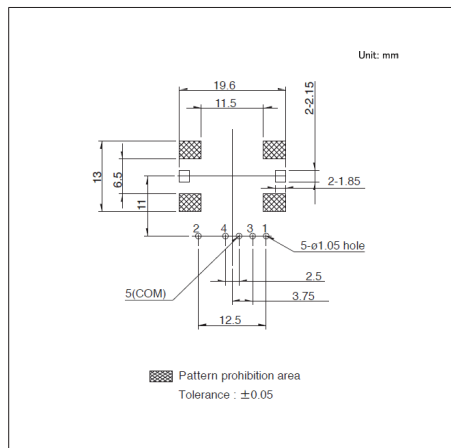

Viewed from mounting face.

18mm Size Insulated Shaft Type
EC18A Series

Drawing No.2

■ Dimensions

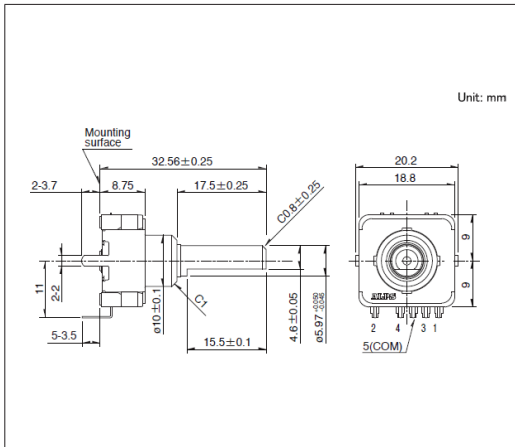

■ Mounting Hole Dimensions

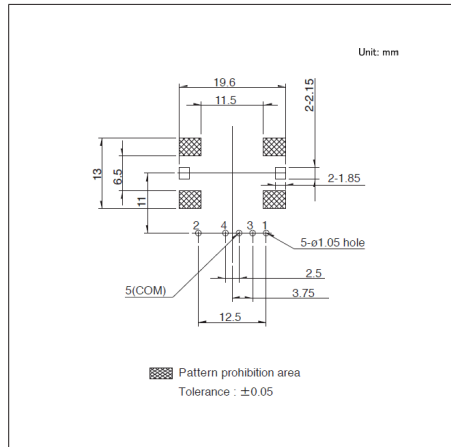

Viewed from mounting face.

Drawing No.3

■ Dimensions

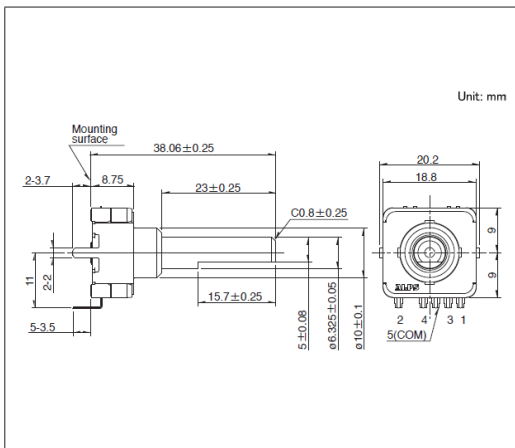

■ Mounting Hole Dimensions

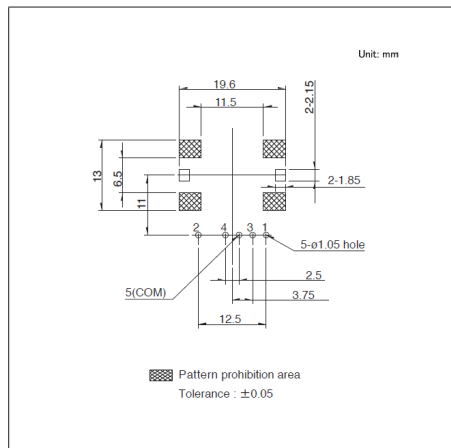

Viewed from mounting face.

EC18A /18mm Size Insulated Shaft Type

■ Standard Codes

EC18AGA

Position No.		1	2	3	4	5	6	7	8	9	10	11	12
Rotation angle (°)		0	30	60	90	120	150	180	210	240	270	300	330
TERMINAL NO.	1		●	●			●	●			●	●	
	2			●	●	●	●						
	3					●	●	●	●	●	●		
	4									●	●	●	●
	5 (COM)	●	●	●	●	●	●	●	●	●	●	●	●

EC18AGB20407

Position No.		1	2	3	4	5	6	7	8	9	10	11	12	13	14	15
Rotation angle (°)		0	24	48	72	96	120	144	168	192	216	240	264	288	312	336
TERMINAL NO.	1	●	●			●	●			●	●			●	●	
	2		●	●	●	●					●	●	●	●		
	3				●	●	●	●	●	●	●	●				
	4								●	●	●	●	●	●	●	●
	5 (COM)	●	●	●	●	●	●	●	●	●	●	●	●	●	●	●

EC18AGB20401

Position No.		1	2	3	4	5	6	7	8	9	10	11	12	13	14	15	16
Rotation angle (°)		0	22.5	45	67.5	90	112.5	135	157.5	180	202.5	225	247.5	270	292.5	315	337.5
TERMINAL NO.	1		●	●			●	●			●	●			●	●	
	2			●	●	●	●					●	●	●	●		
	3					●	●	●	●	●	●	●	●				
	4									●	●	●	●	●	●	●	●
	5 (COM)	●	●	●	●	●	●	●	●	●	●	●	●	●	●	●	●

1. The ● marks shows the ON position.



2. The ● marks:Connections between terminals and the 5(COM)are ON.

■ Water-proof Property

Immersion of encoder, not in operation, in water at depth of 1m at normal temperature for 30 minutes.

Through shaft Encoder

List of Varieties

Series		EC05E	EC10E
Photo			
Dimensions		5mm size	10mm size
Output		Incremental (Two phase A and B)	
Number of detent		12	12 24
Number of pulse		12	
Operating temperature range		-30°C to +85°C	-5°C to +45°C -40°C to +85°C
Operating life		100,000 cycles	
Electrical performance	Ratings	0.55mA 5.5V DC	1mA 5V DC
	Max./min. operating current (Resistive load)	0.55mA/-	—
	Insulation resistance	50MΩ min. 50V DC	
	Voltage proof	50V AC for 1 minute	
Mechanical performance	Detent torque	1.6±1.3mN·m	—
Automotive		—	●

 Note

● Indicates applicability to all products in the series, while ○ indicates applicability to some products in the series.

Encoders

Through shaft Encoder

5mm Size Hollow Shaft Type
EC05E Series

Compact design featuring Drum Cord™ technology.



- Output signal: Two phase A and B
- Ratings: 0.55mA 5.5V DC
- Operating life: 100,000 cycles

Applications: Mobile: Headsets, wearables, Notebooks, peripherals
 Energy Industrial: Robots, drones
 Game: Home handheld consoles, Virtual/augmented reality
 Healthcare: Healthcare equipment, Nursing care equipment,
 Analysis, test equipment

■ Product List

Products No.	Control part orientation	Detent torque	Mount height	Number of detent	Number of pulse	Automotive	Drawing No.
EC05E1220202	Horizontal	1.6±1.3mN·m	4.5mm	12	12	—	1
EC05E1220203	Horizontal	1.6±1.3mN·m	4.5mm	12	12	—	2
EC05E1220401	Vertical	1.6±1.3mN·m	—	12	12	—	3

⚠ Note

1. This catalog shows only outline specifications. When using the products, please obtain formal specifications for supply.
2. Please place purchase orders per minimum order unit (integer).

■ Packing Specifications

Taping

Products No.	Number of packages (pcs.)			Tape width (mm)	Export package measurements (mm)
	1 reel	1 case / Japan	1 case / export packing		
EC05E1220202 EC05E1220203	1,000	4,000	8,000	16	485 x 410 x 246
EC05E1220401	2,000	8,000	16,000	16	485 x 410 x 246

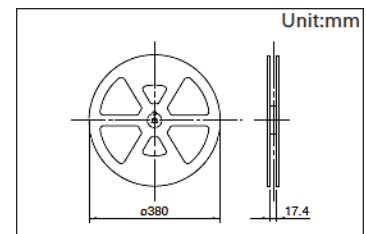

Drawing No. 1

■ Dimensions

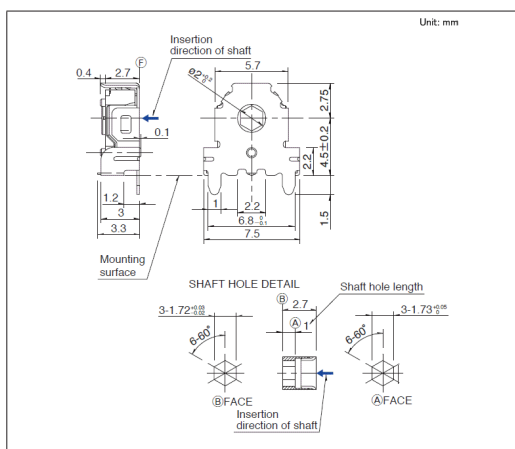

■ Mounting Hole and Land Dimensions

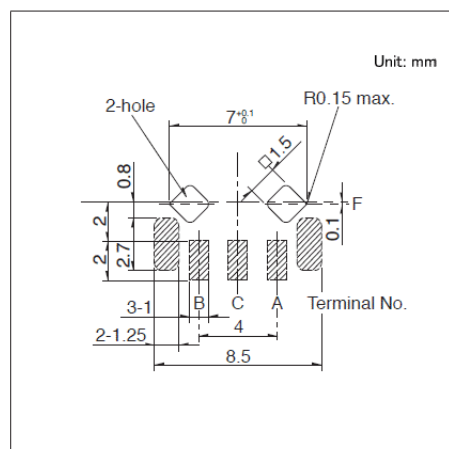

Viewed from mounting side.
 shaded area indicated soldering land.

5mm Size Hollow Shaft Type
EC05E Series

Drawing No.2

■ Dimensions

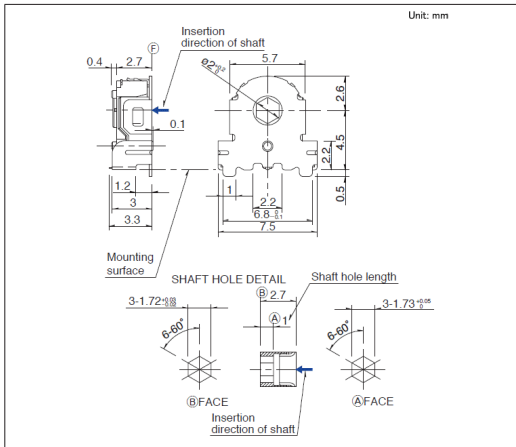

■ Mounting Hole and Land Dimensions

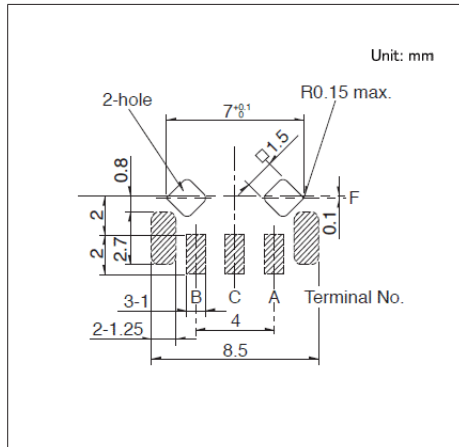

Viewed from mounting side,
shaded area indicated soldering land.

Drawing No.3

■ Dimensions

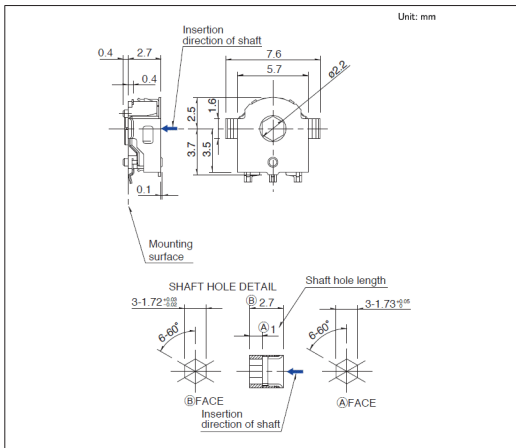

■ Mounting Hole and Land Dimensions

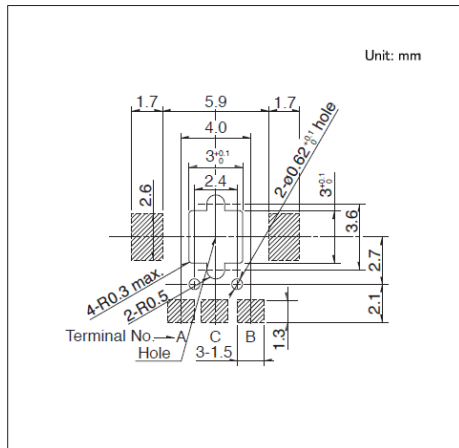

Viewed from mounting side,
shaded area indicated soldering land.

Encoders Through shaft Encoder

10mm Size Hollow Shaft Type
EC10E Series

Unique through-shaft design achieving miniaturization and long life.

 Automotive



- Output signal: Two phase A and B
- Ratings: 1 mA 5V DC
- Operating life: 100,000 cycles

Applications: Mobile: Notebooks, peripherals
 Energy_Industrial: Robots, drones
 Game: Home handheld consoles
 Automotive: Navigation/audio systems, HVAC, Steering

■ Product List

Products No.	Control part orientation	Detent torque	Mount height	Number of detent	Number of pulse	Automotive	Drawing No.
EC10E1220505	Horizontal	5±3mN·m	7.0mm	24	12	●	1
EC10E1220501	Horizontal	5±3mN·m	9.0mm	24	12	●	2
EC10E1220503	Horizontal	5±3mN·m	11.0mm	24	12	●	3
EC10E1260502	Horizontal	6±3mN·m	7.0mm	12	12	●	4
EC10E1260507	Horizontal	6±3mN·m	11.0mm	24	12	●	5

 Note

1. This catalog shows only outline specifications. When using the products, please obtain formal specifications for supply.
2. Please place purchase orders per minimum order unit (integer).
3. Please contact us for automotive use products.

■ Packing Specifications

Bulk

Number of packages (pcs.)		Export package measurements (mm)
1 case / Japan	1 case / export packing	
3,200	3,200	374 x 254 x 166

Drawing No.1

■ Dimensions

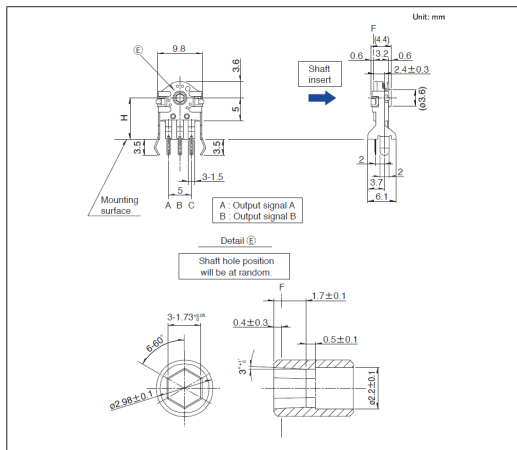

Mount height H = 7mm

■ Mounting Hole Dimensions

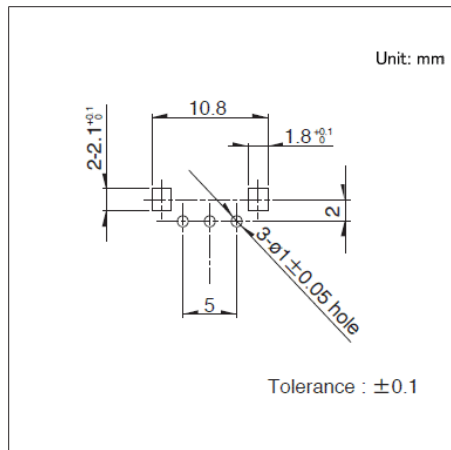

Viewed from mounting side

10mm Size Hollow Shaft Type
EC10E Series

Drawing No.5

■ Dimensions

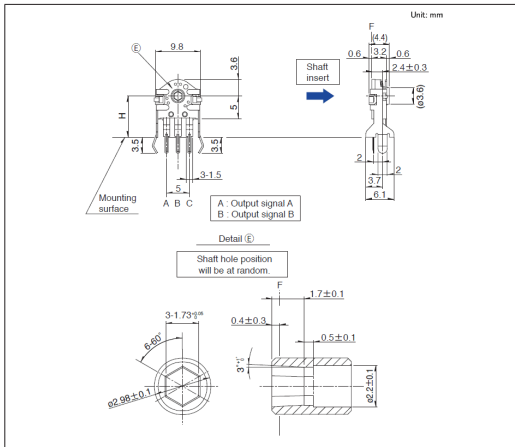

Mount height H = 11mm

■ Mounting Hole Dimensions

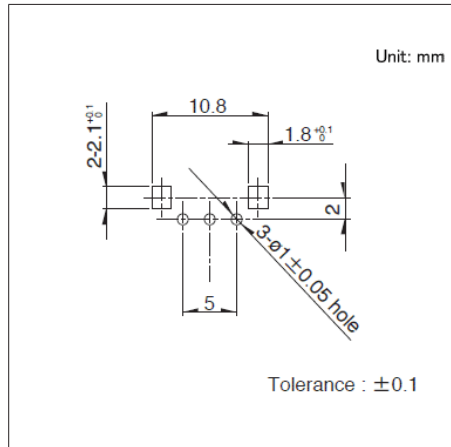







Viewed from mounting side

Encoders

Ring Encoder

List of Varieties

Series		EC21A/EC21C	EC28A/EC28C	EC35A	EC35AH/ EC35CH	EC40A	EC50A	
Photo								
Dimensions		21mm size	28mm size	35mm size		40mm size	50mm size	
Output		Incremental (Two phase A and B)			Incremental (Three phase A, B and C)	Incremental (Two phase A and B)		
Detent torque		7±5mN·m 12±5mN·m 16±7mN·m 17±8mN·m (Initial) 12(+7, -4)mN·m (After reflow)	7±5mN·m 12±7mN·m 20±10mN·m 22±11mN·m (Initial) 16±7mN·m (After reflow)	18±7mN·m 22±8mN·m 30±15mN·m	12±5mN·m 18±7mN·m 22±11mN·m (Initial) 18±7mN·m (After reflow) 30±15mN·m	20±11mN·m 40±16mN·m	40±14mN·m	
Number of detent		18 30				30	18	
Number of pulse		9 15	15 18	9 15	6 10	15	9	
Operating temperature range		-40°C to +85°C	-40°C to +85°C -40°C to +90°C	-40°C to +85°C	-40°C to +85°C -40°C to +90°C	-40°C to +85°C		
Operating life		50,000 cycles				30,000 cycles	40,000 cycles	
Electrical performance	Ratings	10mA 5V DC				0.5mA 5V DC	1mA 5V DC	
	Max./min. operating current (Resistive load)	10mA/1mA				—		
	Insulation resistance	100MΩ min. 250V DC				10MΩ min. 50V DC	10MΩ min. 250V DC	
	Voltage proof	300V AC for 1 minute or 360V AC for 1s 300V AC for 1 minute or 360V AC for 2s		300V AC for 1 minute or 360V AC for 2s	300V AC for 1 minute or 360V AC for 1s 300V AC for 1 minute or 360V AC for 2s	50V AC for 1 minute	50V AC for 1 minute or 60V AC for 2s	
Mechanical performance	Actuator strength	Pushing direction	100N					
		Pulling direction	100N			50N		
Automotive		●	●	●	●	●	●	

 Note

● Indicates applicability to all products in the series, while ○ indicates applicability to some products in the series.

21 mm Size Ring Type EC21A/EC21C Series

Hollow type suited for multifunctionality, offering a thin 4.0mm thickness for space savings.

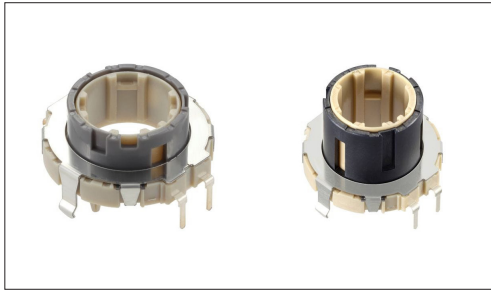

 Automotive

- Output signal: Two phase A and B
- Ratings: 10mA 5V DC
- Operating life: 50,000 cycles

Applications: Home: Major home appliances, Office equipment
Audio_TV: Visual
Automotive: Navigation/audio systems, HVAC

■ Product List

Products No.	Actuator length (mm)	Detent torque	Number of detent	Number of pulse	Automotive	Drawing No.
EC21A1540401	9.0	7±5mN·m	30	15	●	1
EC21A1520401	9.0	16±7mN·m	30	15	●	
EC21A0920401	9.0	16±7mN·m	18	9	●	2
EC21A1520407	15.0	16±7mN·m	30	15	●	3
EC21A0950402	15.0	12±5mN·m	18	9	●	4
EC21C1520402	12.0	17±8mN·m (Initial) 12(+7, -4)mN·m (After reflow)	30	15	●	5

Note

1. This catalog shows only outline specifications. When using the products, please obtain formal specifications for supply.
2. Please place purchase orders per minimum order unit (integer).

■ Packing Specifications

Tray

Products No.	Number of packages (pcs.)		Export package measurements (mm)
	1 case / Japan	1 case / export packing	
EC21A1540401 EC21A1520401	600	1,200	508 x 364 x 192
EC21A0920401	240	480	375 x 285 x 223
EC21A1520407 EC21A0950402	600	1,200	540 x 360 x 290
EC21C1520402	640	640	400 x 310 x 185

21 mm Size Ring Type
EC21A/EC21C Series

Drawing No.1

■ Dimensions

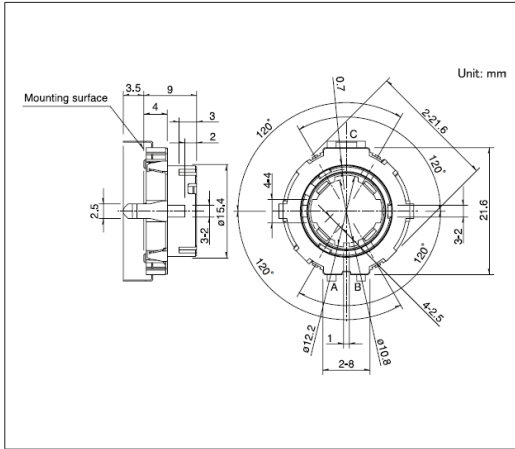

■ Mounting Hole Dimensions

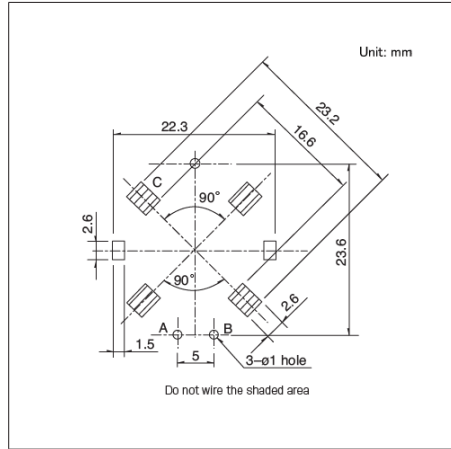

Viewed from mounting side

Drawing No.2

■ Dimensions

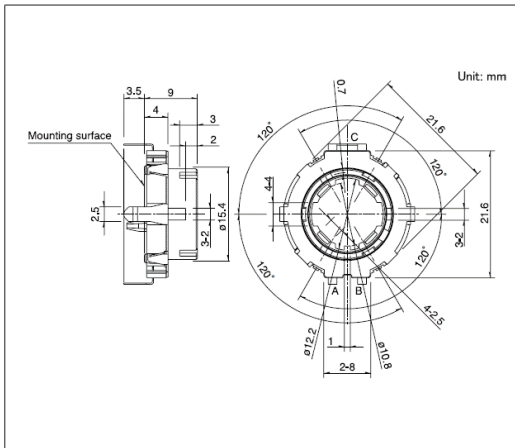

■ Mounting Hole Dimensions

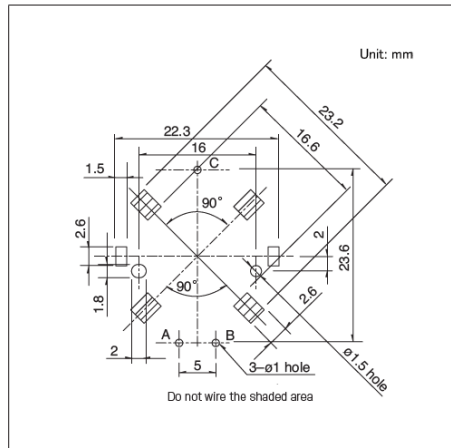

Viewed from mounting side

Drawing No.3

■ Dimensions

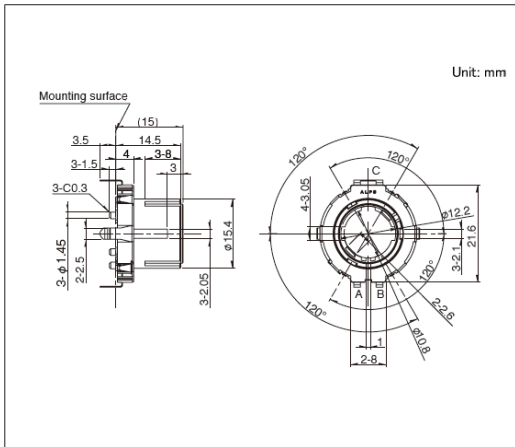

■ Mounting Hole Dimensions

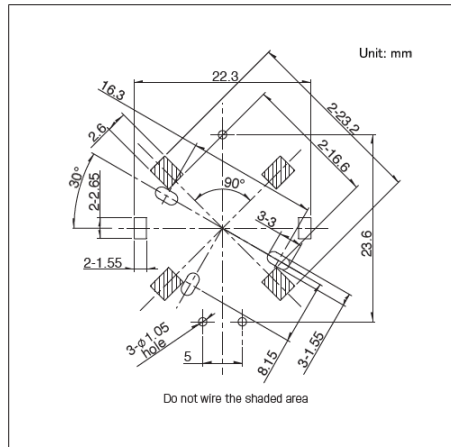

Viewed from mounting side

21mm Size Ring Type
EC21A/EC21C Series

Drawing No.4

■ Dimensions

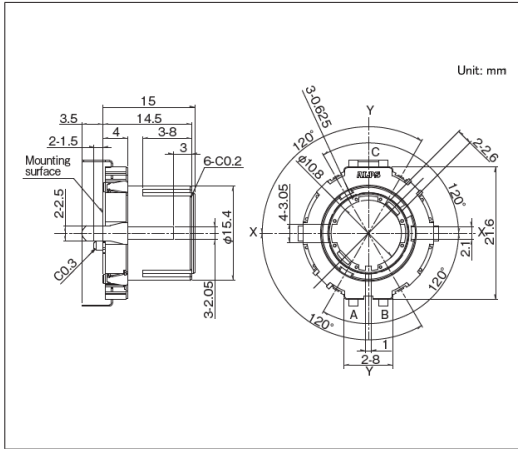

■ Mounting Hole Dimensions

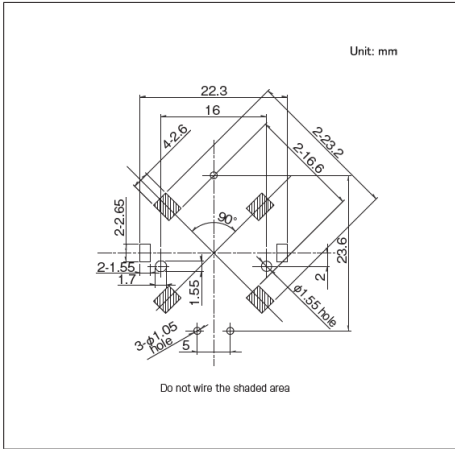

Viewed from mounting side

Drawing No.5

■ Dimensions

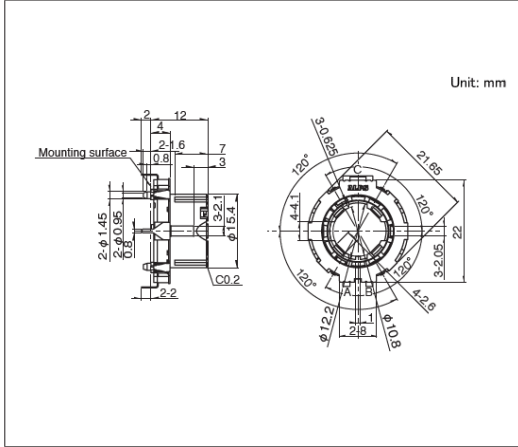

28mm Size Ring Type

EC28A/EC28C Series

Thin-profile design with a 4.0mm body thickness and excellent operation feel.

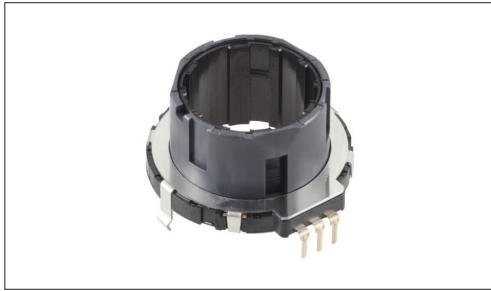
 Automotive

- Output signal: Two phase A and B
- Ratings: 10mA 5V DC
- Operating life: 50,000 cycles

Applications: Home: Major home appliances, Office equipment
 Audio_TV: Visual
 Automotive: Navigation/audio systems, HVAC

■ Product List

Products No.	Actuator length (mm)	Detent torque	Number of detent	Number of pulse	Automotive	Drawing No.
EC28A1520401	15.0	7±5mN·m	30	15	●	1
EC28A1550401	15.0	12±7mN·m	30	15	●	
EC28A1560401	15.0	20±10mN·m	30	15	●	
EC28A1850402	15.0	12±7mN·m	18	18	●	
EC28A1870401	15.0	20±10mN·m	18	18	●	
EC28A1560501	25.0	20±10mN·m	30	15	●	2
EC28C1540403	15.0	22±11mN·m (Initial) 16±7mN·m (After reflow)	30	15	●	3

 Note

1. This catalog shows only outline specifications. When using the products, please obtain formal specifications for supply.
2. Please place purchase orders per minimum order unit (integer).

■ Packing Specifications

Tray

Products No.	Number of packages (pcs.)		Export package measurements (mm)
	1 case / Japan	1 case / export packing	
EC28A1520401 EC28A1550401 EC28A1560401 EC28A1850402 EC28A1870401	400	800	509 x 366 x 287
EC28A1560501	420	840	540 x 360 x 380
EC28C1540403	480	480	440 x 290 x 205

Encoders Ring Encoder

35mm Size Ring Type
EC35A Series

Thin-profile design with a 4.5mm body thickness and excellent operation feel.

 Automotive



- Output signal: Two phase A and B
- Ratings: 10mA 5V DC
- Operating life: 50,000 cycles

Applications: Home: Office equipment
Audio_TV: Visual
Automotive: Navigation/audio systems, HVAC

■ Product List

Products No.	Actuator length (mm)	Detent torque	Number of detent	Number of pulse	Automotive	Drawing No.
EC35A1520402	20.0	18±7mN·m	30	15	●	1
EC35A0930401	20.0	22±8mN·m	18	9	●	2
EC35A1550502	25.0	30±15mN·m	30	15	●	3

 Note

1. This catalog shows only outline specifications. When using the products, please obtain formal specifications for supply.
2. Please place purchase orders per minimum order unit (integer).

■ Packing Specifications

Tray

Products No.	Number of packages(pcs.)		Export package measurements (mm)
	1 case / Japan	1 case / export packing	
EC35A1520402 EC35A0930401	420	840	540 x 360 x 380
EC35A1550502	350	700	540 x 360 x 380

Drawing No. 1

■ Dimensions

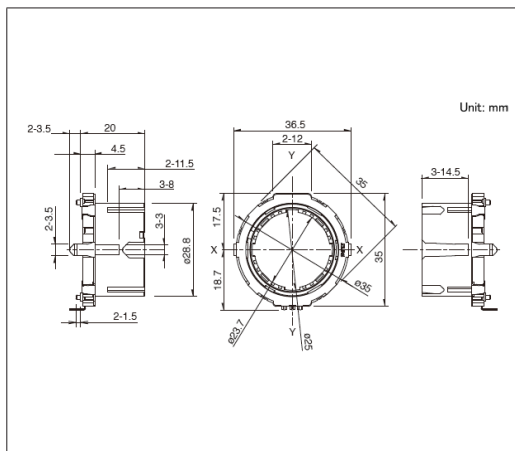

■ Mounting Hole Dimensions

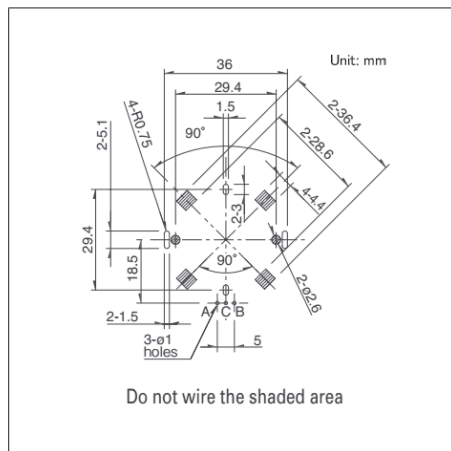

Viewed from mounting side

35mm Size Ring Type
EC35A Series

Drawing No.2

■ Dimensions

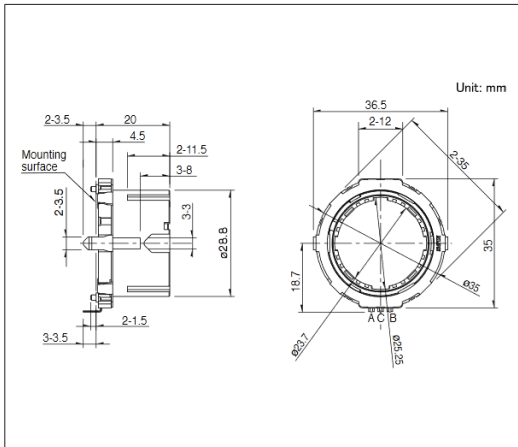

■ Mounting Hole Dimensions

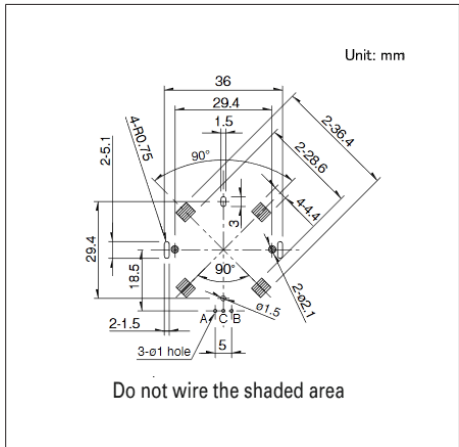

Viewed from mounting side

Drawing No.3

■ Dimensions

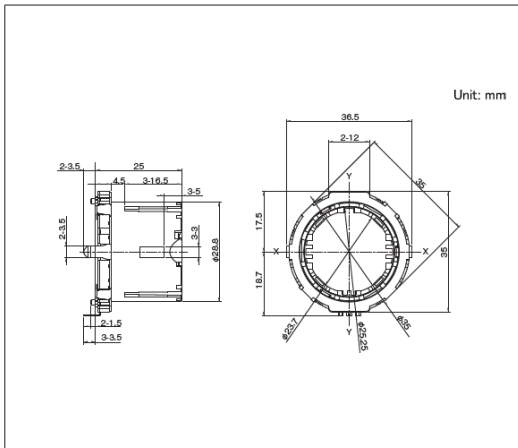

■ Mounting Hole Dimensions

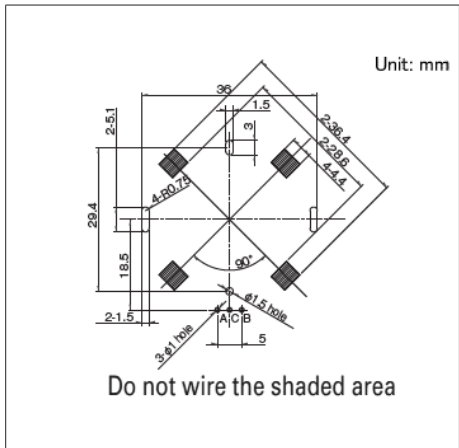

Viewed from mounting side

Encoders

Ring Encoder

35mm Size ABC Switch Type

EC35AH/EC35CH Series

Hollow-shaft encoder capable of three-phase output for composite applications.

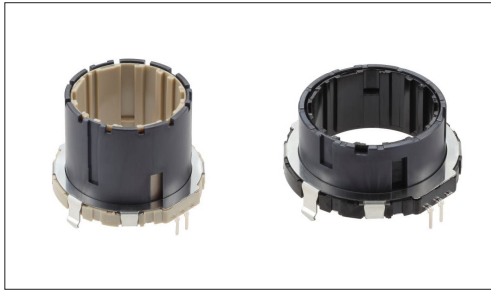
 Automotive

- Output signal: Three phase A, B and C
- Ratings: 10mA 5V DC
- Operating life: 50,000 cycles

Applications: Automotive: Navigation/audio systems, HVAC

■ Product List

Products No.	Actuator length (mm)	Detent torque	Number of detent	Number of pulse	Automotive	Drawing No.
EC35AH240403	15.0	12±5mN·m	30	10	●	1
EC35AH220403	15.0	18±7mN·m	30	10	●	
EC35AH260403	15.0	30±15mN·m	30	10	●	
EC35AH240502	25.0	12±5mN·m	30	10	●	2
EC35AH220502	25.0	18±7mN·m	30	10	●	
EC35AH260502	25.0	30±15mN·m	30	10	●	
EC35AH120401	15.0	18±7mN·m	18	6	●	3
EC35CH120401	14.9	22±11mN·m (Initial) 18±7mN·m (After reflow)	18	6	●	4

 Note

1. This catalog shows only outline specifications. When using the products, please obtain formal specifications for supply.
2. Please place purchase orders per minimum order unit (integer).

■ Packing Specifications

Tray

Products No.	Number of packages(pcs.)		Export package measurements (mm)
	1 case / Japan	1 case / export packing	
EC35AH240403 EC35AH220403 EC35AH260403 EC35AH120401	800	800	540 x 360 x 290
EC35AH240502 EC35AH220502 EC35AH260502	350	700	540 x 360 x 380
EC35CH120401	384	384	440 x 290 x 205

Drawing No.4

■ Dimensions

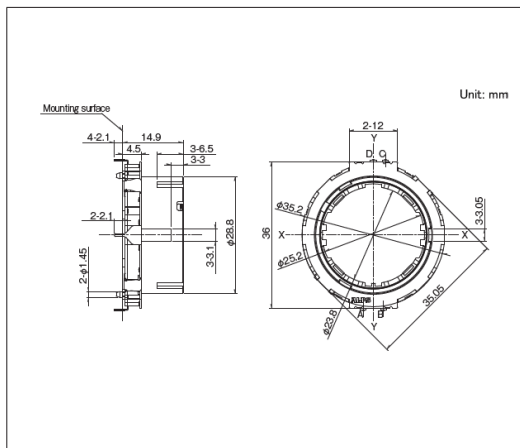

Encoders Ring Encoder

40mm Size Ring Type
EC40A Series

Delivers excellent operation feel with minimized shaft play.

 Automotive



- Output signal: Two phase A and B
- Ratings: 0.5mA 5V DC
- Operating life: 30,000 cycles

Applications: Automotive: Navigation/audio systems, HVAC

■ Product List

Products No.	Actuator length (mm)	Detent torque	Number of detent	Number of pulse	Automotive	Drawing No.
EC40A1520403	22.0	20±11mN·m	30	15	●	1
EC40A1520405	22.0	40±16mN·m	30	15	●	

 Note

1. This catalog shows only outline specifications. When using the products, please obtain formal specifications for supply.
2. Please place purchase orders per minimum order unit (integer).

■ Packing Specifications

Tray

Number of packages (pcs.)		Export package measurements (mm)
1 case / Japan	1 case / export packing	
200	400	540 x 360 x 380

Drawing No.1

■ Dimensions

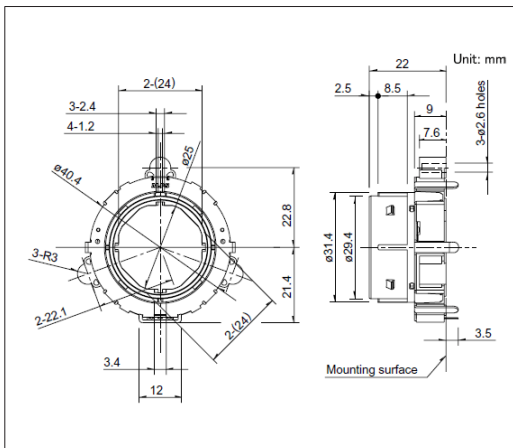

■ Mounting Hole Dimensions

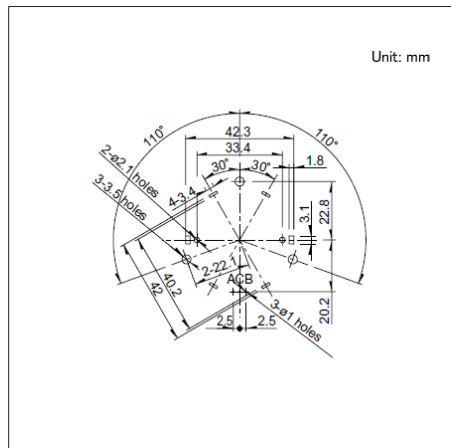

Viewed from mounting side

Encoders

Ring Encoder

50mm Size Ring Type
EC50A Series

Large design with an inner diameter of $\phi 37$ mm, capable of housing a small LCD.

 Automotive



- Output signal: Two phase A and B
- Ratings: 1 mA 5V DC
- Operating life: 40,000 cycles

Applications: Automotive: Navigation/audio systems, HVAC

■ Product List

Products No.	Actuator length (mm)	Detent torque	Number of detent	Number of pulse	Automotive	Drawing No.
EC50A0920404	14.5	40±14mN·m	18	9	●	1

 Note

1. This catalog shows only outline specifications. When using the products, please obtain formal specifications for supply.
2. Please place purchase orders per minimum order unit (integer).

■ Packing Specifications

Tray

Number of packages (pcs.)		Export package measurements (mm)
1 case / Japan	1 case / export packing	
200	400	540 x 360 x 290

Drawing No.1

■ Dimensions

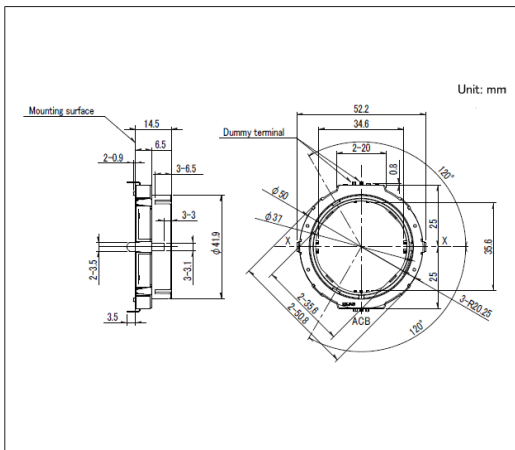

■ Mounting Hole Dimensions

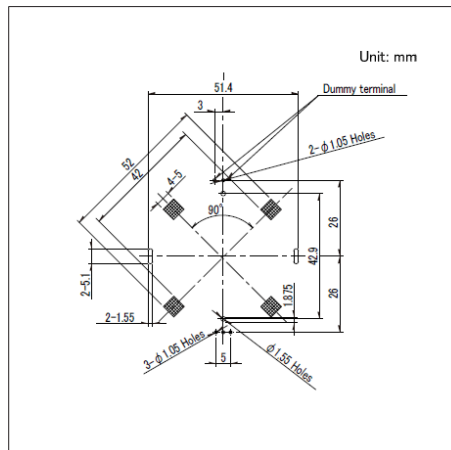

Viewed from mounting side
Wiring prohibited on hatched area

Encoders / Soldering Conditions

■ Reference for Manual Soldering

Series	Tip temperature	Soldering time	No. of solders
EC05E, EC09E, EC10E, EC111, EC11E, EC11M, EC12D, EC12E, EC18A, EC21A, EC28A, EC35A, EC35AH, EC40A, EC50A, EC21C, EC28C, EC35CH	350°C max.	3s max.	1 time

■ Reference for Dip Soldering

Series	Preheating		Dip soldering		No. of solders
	Soldering surface temperature	Heating time	Soldering temperature	Soldering time	
EC09E, EC111, EC11E, EC11M, EC18A, EC21A, EC28A, EC35A, EC35AH, EC50A	100°C max.	2 min. max.	260±5°C	5±1s	2 times max.
EC10E, EC12D, EC12E	100°C max.	1 min. max.	260±5°C	3±1s	2 times max.
EC40A	110°C max.	1 min. max.	260°C max.	10s max.	1 time

■ Example of Reflow Soldering Condition

Temperature profile

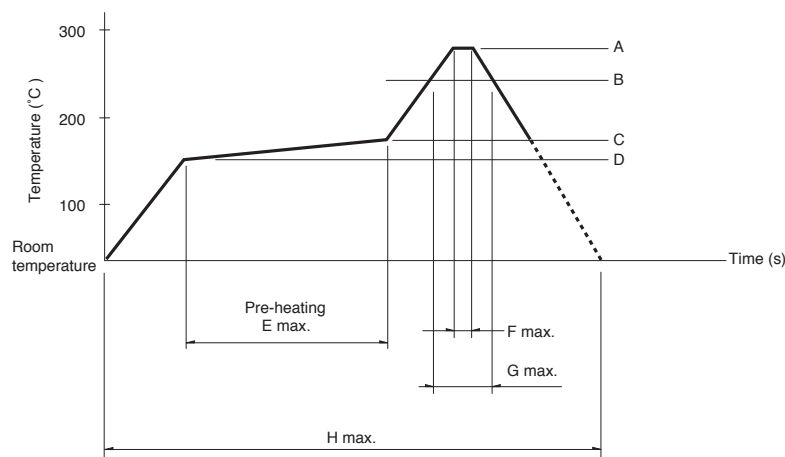

Series	A	B	C	D	E	F	G	H	No. of reflows
EC05E	250°C min.	230°C min.	180°C	150°C	60s to 120s	—	30s to 40s	—	2 times max.
EC21C	230°C to 245°C	220°C	200°C	150°C	60s to 120s	—	25s to 60s	300s max.	1 time max.
EC28C, EC35CH	260°C	230°C	180°C	150°C	2 min. min.	3s	40s	230s max.	1 time max.

⚠ Note

- When using an infrared reflow oven, solder may sometimes not be applied. Be sure to use a hot air reflow oven or a type that uses infrared rays in combination with hot air.
- The temperatures given above are the maximum temperatures at the terminals of the encoder when employing a hot air reflow method. The temperature of the PC board and the surface temperature of the encoder may vary greatly depending on the PC board material, its size and thickness. Ensure that the surface temperature of the encoder does not rise to 250°C or greater.
- Conditions vary to some extent depending on the type of reflow bath used. Be sure to give due consideration to this prior to use.

Encoders / Cautions

Pulse count process

With respect to pulse count design of encoders, operational speed, sampling time, and masking time, etc. should be taken into consideration. Be sure to confirm these factors before using the encoder. For your pulse count design, consider adding C/R filters on your circuit as shown below.

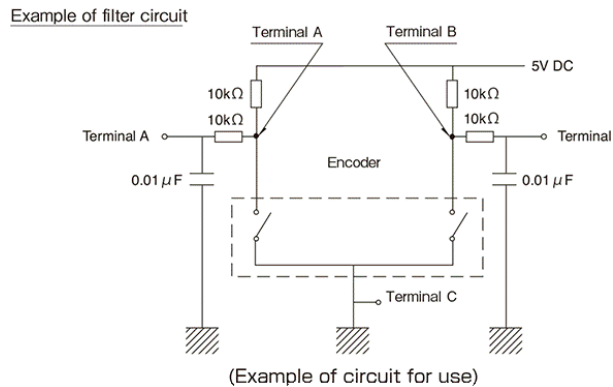

Output Specifications

Depending on the product, output at encoder detent positions can be specified either for both signals A and B, or for signal A only. Specifications vary according to the number of detents and other factors.

Example where both signal A and B output can be specified

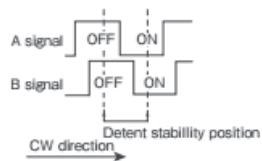

Example where only signal A output can be specified

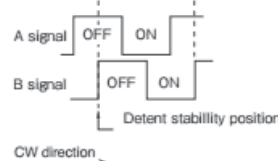

※ On / off status of signal B at detent stability point is not specified

Dew Condensation

Do not use this product where dew or water drops might occur on the pattern surface of the encoder, etc. Insulation deterioration or shorting may occur.

Usage Environment

Use of the encoders in a dusty environment may lead the dusts entering through the openings and cause imperfect contact or malfunction. Take this into account for set design. Corrosive gas if generated by peripheral parts of a set, malfunction such as imperfect contact may occur. Thorough investigation shall be required before hand.

Operation

The encoders will be break if you apply a greater stress than that specified. Take great care not to let the encoders be subject to greater stress than specified.

Looseness of the Shaft

When long shafts are being employed, the looseness (deviation) tends to grow in proportion to the shaft length. Checking shaft looseness under actual operational conditions is recommended.

Installation

Insert these encoders to the specified mounting surface and mount them horizontally. If not mounted horizontally, these encoders will malfunction. Tighten the mounting screws by applying the specified torque. Tightening with larger torque than the specified one will result in malfunction or breakage of screws. Protect small and thin encoders from external forces in the set mounting process.

Encoders / Cautions

Soldering

1. To avoid potential contact issues, please do not solder wires to the top surface of the printed circuit board as shown in the diagram.
Solder all metal lugs into a substrate before use.

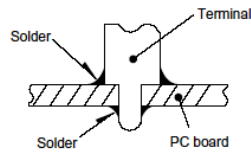

2. Applying load to terminals during soldering under certain conditions may cause deformation and electrical property degradation.
3. Avoid use of water-soluble soldering flux, since it may corrode the switches.
4. Check and conform to soldering requirements under actual mass production conditions.
5. When soldering twice, wait until the first soldered portion cools to normal temperature. Continuous heating will deform the external portions, loosen or dislodge terminals, or may deteriorate their electrical characteristics.
6. Flux from around and above the PC board should not adhere to the switches.
7. After mounting the switches, if you intend to put the board into an oven in order to harden adhesive for other parts, please consult with Alps Alpine.
8. If you use a through-hole PC board or a PC board thinner or thicker than the recommendation, there may be greater heat stress. Verify the soldering conditions thoroughly before use.
9. Solder the switches with detent at the detent position. Soldering switches fixed at the center of the detent may deform the detent mechanisms.
10. No washing.

Use of Chemicals

Since synthetic resins such as polycarbonate are being used as the material for the insulated type shafts, avoid using this product under gassy environments containing such chemicals as ammonia, amines, alkaline water solutions, aromatic hydrocarbons, ketones, esters and halogenated hydrocarbons, especially under intensive gas environments.

Operation at Low Temperature

When these products are expected to be used under low temperature environments such as applications for car radios and car stereos, we can customize them for easier and more smooth rotary movements. When placing orders, indicate whether the low temperature specification is necessary or not.

Storage

1. Store the products as delivered, at a normal temperature and humidity, without direct sunshine and corrosive gas ambient. Use them at an earliest possible timing, not later than six months upon receipt.
2. After breaking the seal, keep the products in a plastic bag to shut out ambient air, store them in the same environment as above, and use them up as soon as possible.
3. Do not stack too many switches.





Potentiometers

- Rotary Potentiometer (Metal shaft type) — 379
- Rotary Potentiometer (Insulated shaft type) — 399
- Rotary Potentiometer (Knob operating type) — 414
- Rotary Potentiometer (Ring type) — 419
- Slide Potentiometer (Standard type) — 424
- Slide Potentiometer (Master type) — 437

Potentiometers

Rotary Potentiometer (Metal shaft type)

List of Varieties

Series		RK09L	RK097	RK163	RK271
Photo					
Dimensions		9mm Size		16mm Size	27mm Size
Attached switch		Without	Without Rotary switch Push-on switch	Without	Without
Control part orientation	Horizontal	●	●	●	●
	Vertical	●	—	—	—
Number of operating shafts		Single-shaft	Dual shaft (Outer-shaft, Inner shaft) Single-shaft	Single-shaft	
Number of resistor elements		Dual-unit Single-unit			
Shaft types		Flat		Flat Serrated	Flat Slotted
Length of the shaft (mm)		15 20 25		15 20	20 25
Detent		Center detent Without			31-position Without
Operating temperature range		-10°C to +70°C	-20°C to +70°C	-10°C to +70°C	
Operating life (cycles)		15,000			
Electrical performance	Total resistance	10kΩ			100kΩ
	Resistance taper	1B 15A			15A
	Total resistance tolerance	±20%			
	Rated power	0.05W		0.05W 0.1W	0.05W
	Maximum operating voltage	50V AC, 10V DC		150V AC, 5V DC	30V AC
	Residual resistance	20Ω max.			100Ω max.
	Insulation resistance	100MΩ min. 250V DC		100MΩ min. 500V DC	
	Voltage proof	300V AC for 1 minute		500V AC for 1 minute	
Mechanical performance	Total rotational angle	300° ±5°	300° ±5° 300° (+10, -5)°	300° ±3°	
	Rotational torque	2 to 25mN·m		3 to 25mN·m	8 to 35mN·m
	Stopper strength	0.5N·m	0.4N·m 0.5N·m	0.9N·m	
	Push-pull strength	80N max.	100N max.		
	Vibration	10 to 55 to 10Hz/min., the amplitude is 1.5mm for all the frequencies, in the 3 direction of X, Y and Z and for 2 hours respectively			
Automotive		—	—	—	—



Note

● Indicates applicability to all products in the series, while ○ indicates applicability to some products in the series.

Potentiometers Rotary Potentiometer (Metal shaft type)

9mm Size Metal Shaft Snap-in Type RK09L Series

Wide variety of single- or dual-gang options, ideal for various control applications.

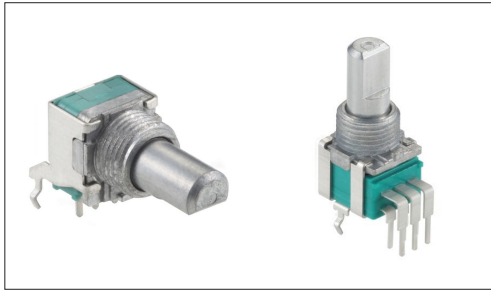

- Total resistance tolerance: $\pm 20\%$
- Maximum operating voltage: 50V AC, 10V DC
- Rotational torque: 2 to 25mN·m
- Operating life: 15,000 cycles
- Operating temperature range: -10°C to $+70^{\circ}\text{C}$

Applications: Home: Major home appliances, Office equipment
Audio_TV: Visual, Audio, Pro audio

■ Product List

Products No.	Number of resistor elements	Control part orientation	Shaft types	Length of the shaft (mm)	Detent	Total resistance	Resistance taper	Automotive	Drawing No.
RK09L1120A5F	Single-unit	Horizontal	Flat	15	Without	10k Ω	1B	—	1
RK09L1120036	Single-unit	Horizontal	Flat	15	Center detent	10k Ω	1B	—	
RK09L1120A0Z	Single-unit	Horizontal	Flat	20	Without	10k Ω	1B	—	2
RK09L112003S	Single-unit	Horizontal	Flat	20	Center detent	10k Ω	1B	—	
RK09L1140A5L	Single-unit	Vertical	Flat	15	Without	10k Ω	1B	—	3
RK09L114001E	Single-unit	Vertical	Flat	15	Center detent	10k Ω	1B	—	
RK09L1140A2U	Single-unit	Vertical	Flat	20	Without	10k Ω	1B	—	4
RK09L114001T	Single-unit	Vertical	Flat	20	Center detent	10k Ω	1B	—	
RK09L122002H	Dual-unit	Horizontal	Flat	15	Center detent	10k Ω	1B	—	5
RK09L122002L	Dual-unit	Horizontal	Flat	25	Center detent	10k Ω	1B	—	6
RK09L12B0A4S	Dual-unit	Horizontal	Flat	15	Without	10k Ω	15A	—	5
RK09L12B0A1V	Dual-unit	Horizontal	Flat	25	Without	10k Ω	15A	—	6
RK09L1240015	Dual-unit	Vertical	Flat	15	Center detent	10k Ω	1B	—	7
RK09L1240019	Dual-unit	Vertical	Flat	20	Center detent	10k Ω	1B	—	8
RK09L12D0A1W	Dual-unit	Vertical	Flat	15	Without	10k Ω	15A	—	7
RK09L12D0A1T	Dual-unit	Vertical	Flat	20	Without	10k Ω	15A	—	8

⚠ Note

1. This catalog shows only outline specifications. When using the products, please obtain formal specifications for supply.
2. Please place purchase orders per minimum order unit (integer).
3. Products other than those listed in above products are also available. Please contact us for details.

■ Packing Specifications

Tray

Number of packages (pcs.)		Export package measurements (mm)
1 case / Japan	1 case / export packing	
1,000	2,000	479 x 369 x 181

9mm Size Metal Shaft Snap-in Type
RK09L Series

Drawing No.1

■ Dimensions

L ₁	15
L _B	5
l ₁	7

Unit:mm

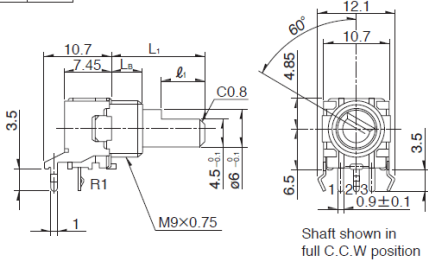

■ Mounting Hole Dimensions

Unit:mm

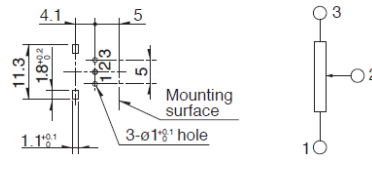

Tolerance: ±0.1

Viewed from mounting side.

Drawing No.2

■ Dimensions

L ₁	20
L _B	7
l ₁	12

Unit:mm

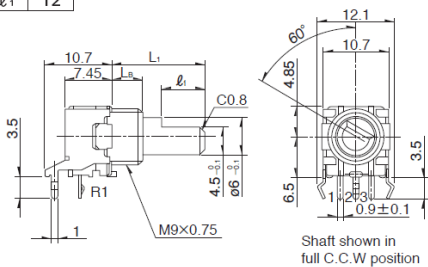

■ Mounting Hole Dimensions

Unit:mm

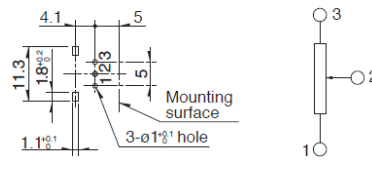

Tolerance: ±0.1

Viewed from mounting side.

Drawing No.3

■ Dimensions

L ₁	15
L _B	5
l ₁	7

Unit:mm

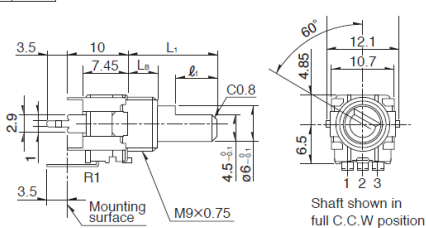

■ Mounting Hole Dimensions

Unit:mm

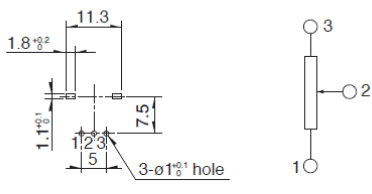

Tolerance: ±0.1

Viewed from mounting side.

9mm Size Metal Shaft Snap-in Type
RK09L Series

Drawing No.4

■ Dimensions

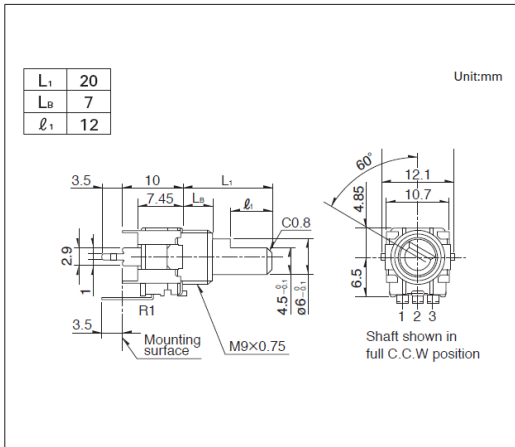

■ Mounting Hole Dimensions

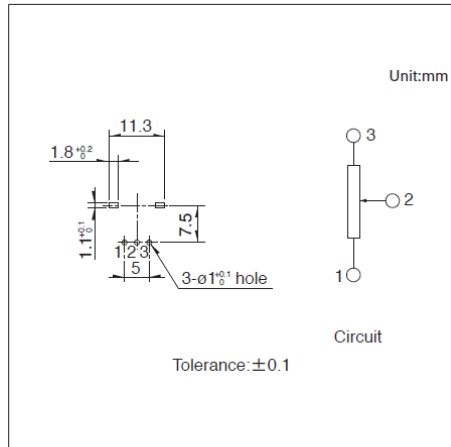

Viewed from mounting side.

Drawing No.5

■ Dimensions

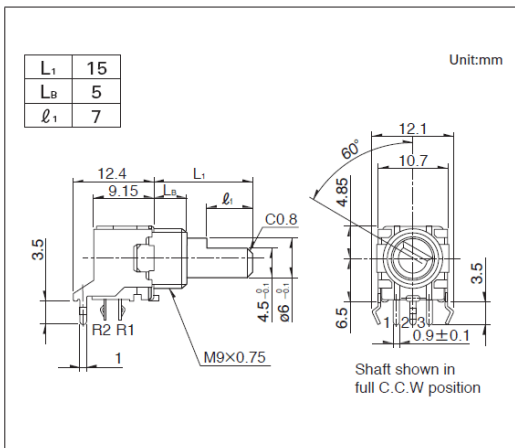

■ Mounting Hole Dimensions

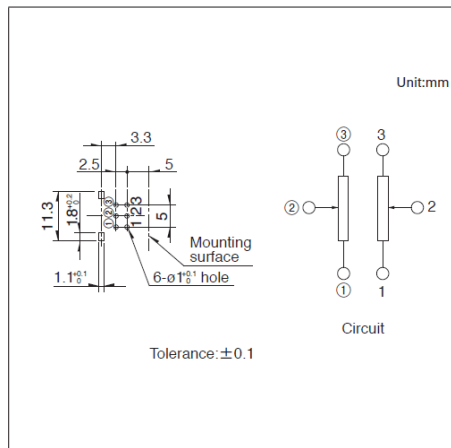

Viewed from mounting side.

Drawing No.6

■ Dimensions

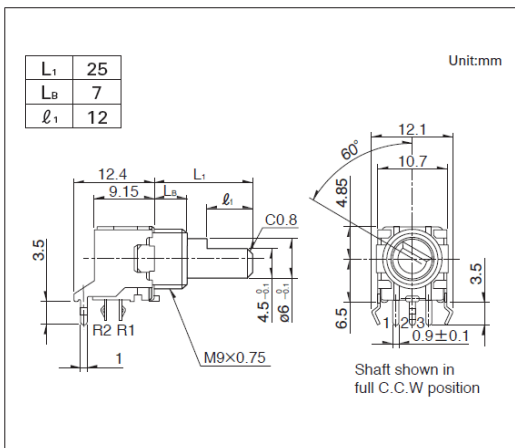

■ Mounting Hole Dimensions

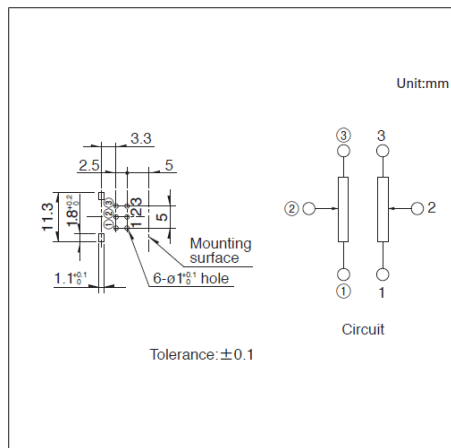

Viewed from mounting side.

9mm Size Metal Shaft Snap-in Type
RK09L Series

Drawing No.7

■ Dimensions

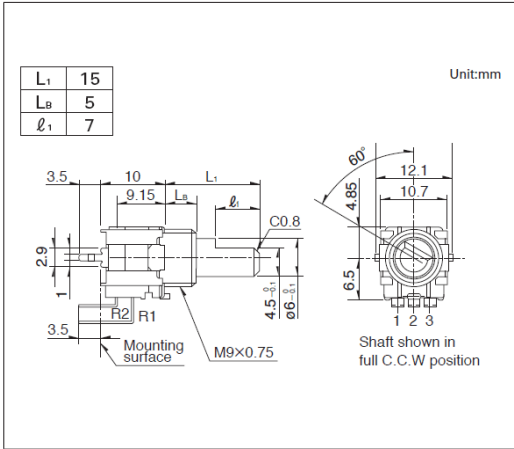

■ Mounting Hole Dimensions

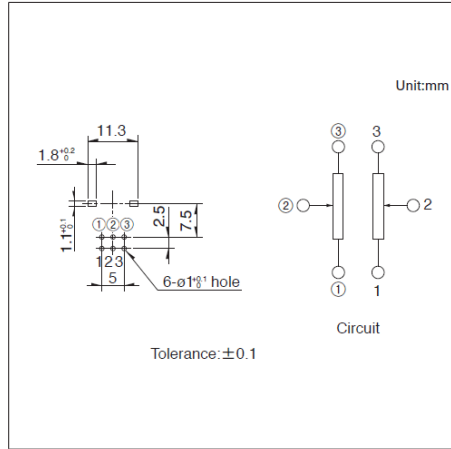

Viewed from mounting side.

Drawing No.8

■ Dimensions

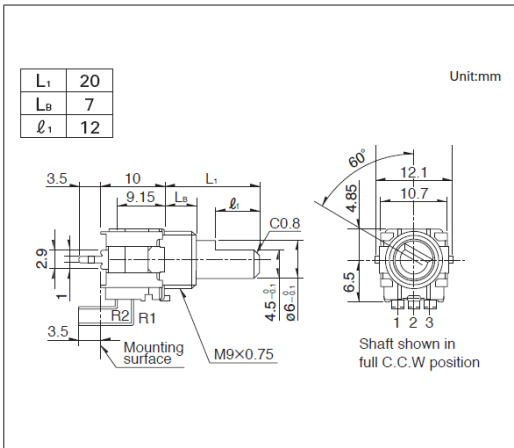

■ Mounting Hole Dimensions

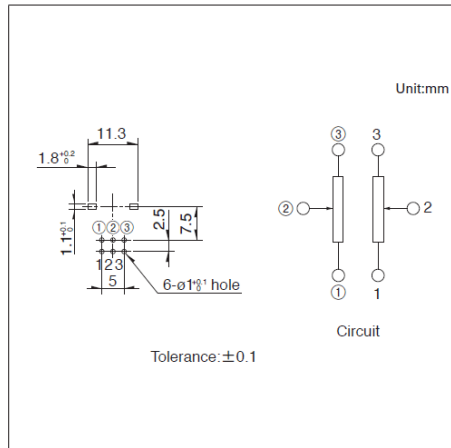

Viewed from mounting side.

9mm Size Metal Shaft Snap-in Type / Attached Parts

The following parts are included with the product.

Unit:mm

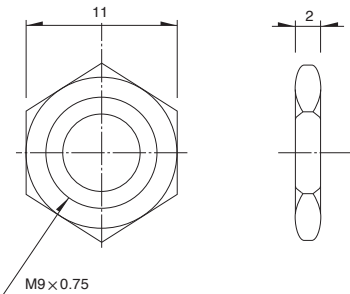
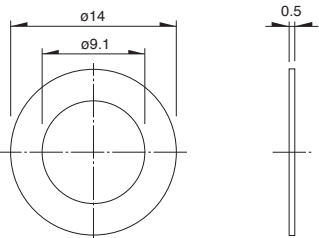
Nut	Washer
 <p>Technical drawing of a hexagonal nut. The top view shows a hexagon with an inscribed circle of diameter 11. The side view shows a height of 2. A label 'M9x0.75' points to the central hole.</p>	 <p>Technical drawing of a circular washer. The top view shows an outer diameter of 14 and an inner hole diameter of 9.1. The side view shows a thickness of 0.5.</p>

Potentiometers Rotary Potentiometer (Metal shaft type)

9mm Size Metal Shaft Multi-ganged Type RK097 Series

Compact type with a 9.5mm body width, suitable for a broad range of control applications.

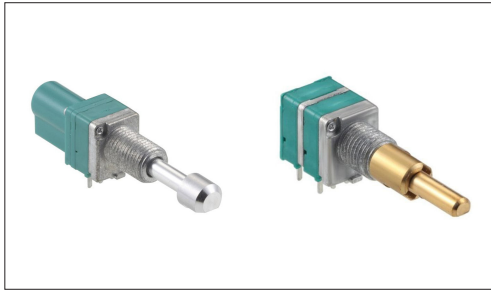

- Total resistance tolerance: $\pm 20\%$
- Maximum operating voltage: 50V AC, 10V DC
- Rotational torque: 2 to 25mN·m
- Operating life: 15,000 cycles
- Operating temperature range: -20°C to $+70^{\circ}\text{C}$

Applications: Home: Major home appliances, Office equipment
Audio_TV: Visual, Audio, Pro audio

■ Product List

Products No.	Type	Number of resistor elements	Control part orientation	Shaft types	Length of the shaft (mm)	Detent	Total resistance	Resistance taper	Automotive	Drawing No.
RK097111080R	Single-shaft without switch type	Single-unit	Horizontal	Flat	20	Without	10k Ω	15A	—	1
RK0971110D88		Single-unit	Horizontal	Flat	20	Center detent	10k Ω	1B	—	
RK0971210DBH		Dual-unit	Horizontal	Flat	20	Center detent	10k Ω	1B	—	2
RK09712200HA		Dual-unit	Horizontal	Flat	20	Without	10k Ω	15A	—	
RK09711110EL	Single-shaft with rotary switch type	Single-unit	Horizontal	Flat	20	Without	10k Ω	1B	—	3
RK0971221Z0X		Dual-unit	Horizontal	Flat	20	Without	10k Ω	15A	—	4
RK0971114Z1N	Single-shaft momentary push (0.5mm-travel) switch	Single-unit	Horizontal	Flat	15	Center detent	10k Ω	1B	—	5
RK0971224Z01		Dual-unit	Horizontal	Flat	20	Without	10k Ω	15A	—	6
RK097111T065	Single-shaft with push-lock mechanism type	Single-unit	Horizontal	Flat	25	Without	10k Ω	1B	—	7
RK097111TD2M		Single-unit	Horizontal	Flat	25	Center detent	10k Ω	1B	—	
RK097122T017		Dual-unit	Horizontal	Flat	25	Without	10k Ω	15A	—	8
RK097221005C	Dual-shaft, dual-unit without switch type	Dual-unit	Horizontal	—	—	—	—	—	—	9

⚠ Note

1. This catalog shows only outline specifications. When using the products, please obtain formal specifications for supply.
2. Please place purchase orders per minimum order unit (integer).
3. This products can be used in vehicles.
4. Products other than those listed in above products are also available. Please contact us for details.

■ Packing Specifications

Tray

Products No.	Number of packages(pcs.)		Export package measurements (mm)
	1 case / Japan	1 case / export packing	
RK097111080R RK0971110D88	1,200	2,400	463 x 375 x 185
RK0971210DBH RK09712200HA	800	1,600	540 x 373 x 207
RK09711110EL RK0971221Z0X RK0971114Z1N RK0971224Z01 RK097111T065 RK097111TD2M RK097221005C	700	1,400	540 x 373 x 181
RK097122T017	600	1,200	540 x 373 x 225

9mm Size Metal Shaft Multi-ganged Type
RK097 Series

Drawing No.1

■ Dimensions

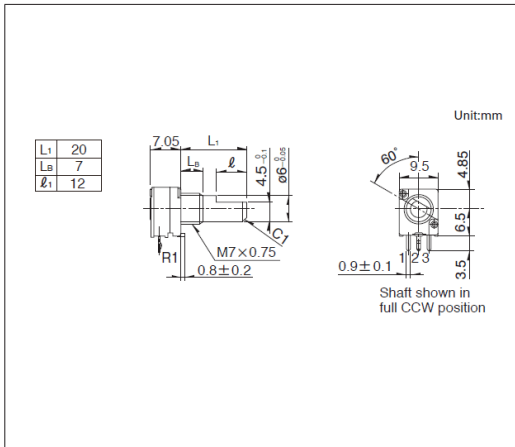

■ Mounting Hole Dimensions

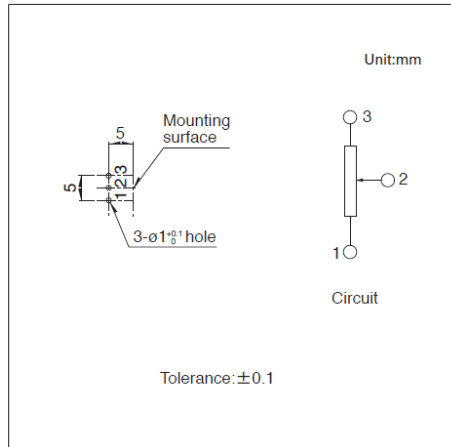

Viewed from mounting side.

Drawing No.2

■ Dimensions

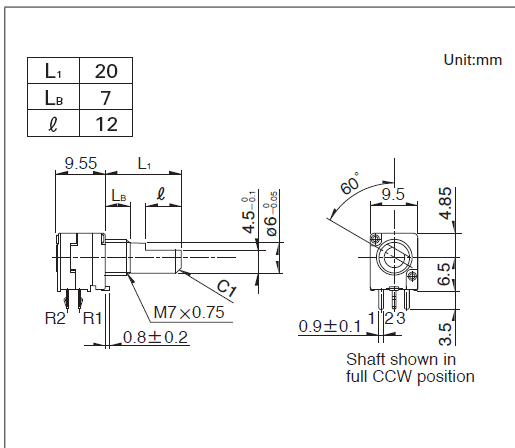

■ Mounting Hole Dimensions

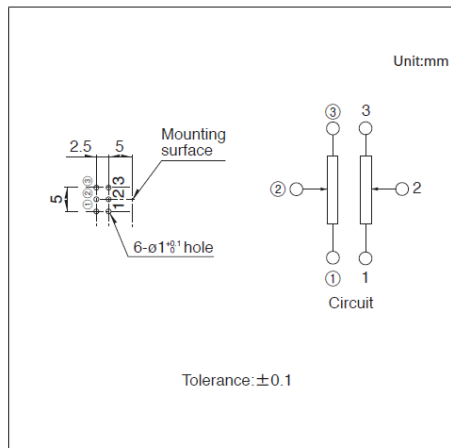

Viewed from mounting side.

Drawing No.3

■ Dimensions

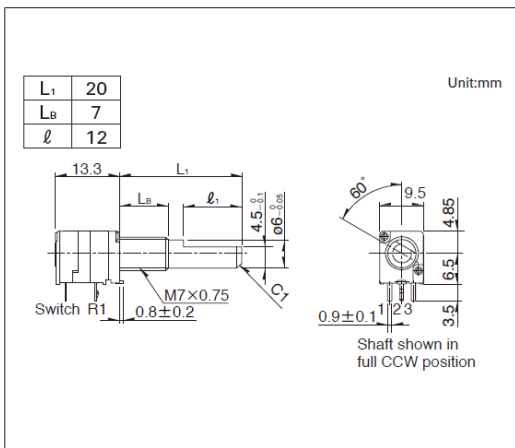

■ Mounting Hole Dimensions

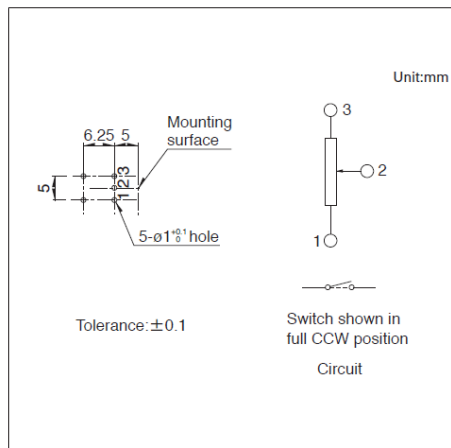

Viewed from mounting side.

9mm Size Metal Shaft Multi-ganged Type
RK097 Series

Drawing No.4

■ Dimensions

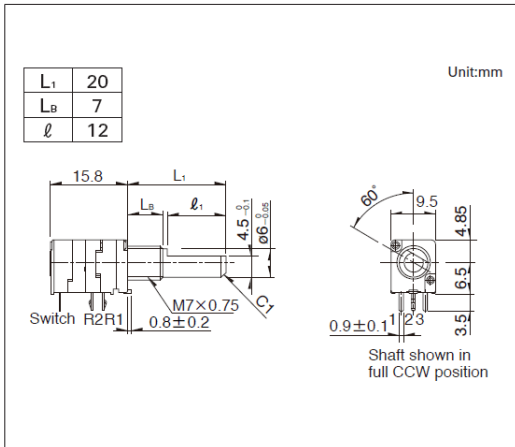

■ Mounting Hole Dimensions

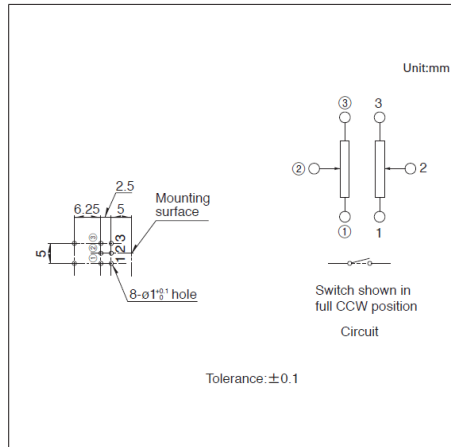

Viewed from mounting side.

Drawing No.5

■ Dimensions

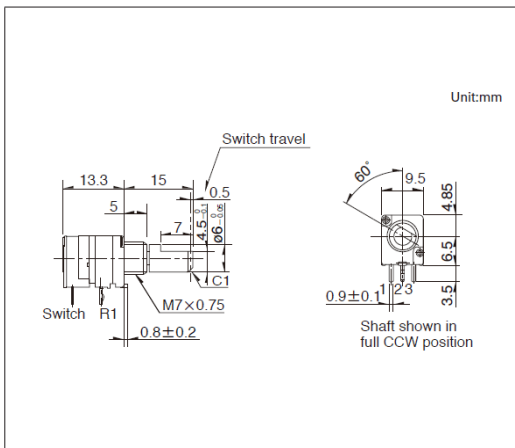

■ Mounting Hole Dimensions

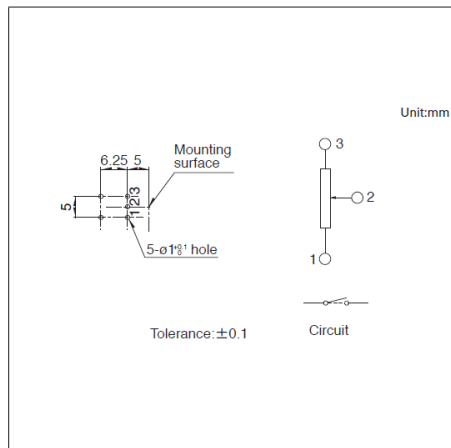

Viewed from mounting side.

Drawing No.6

■ Dimensions

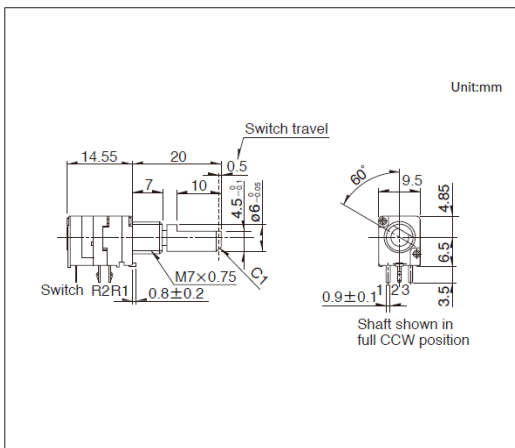

■ Mounting Hole Dimensions

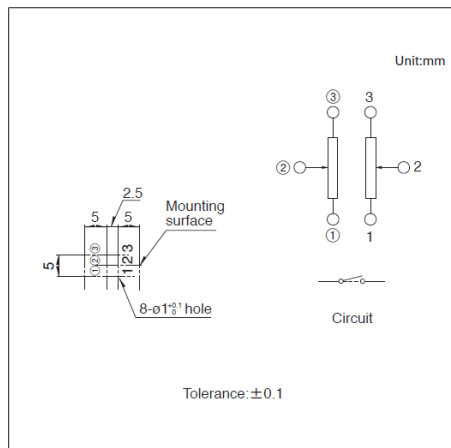

Viewed from mounting side.

9mm Size Metal Shaft Multi-ganged Type
RK097 Series

Drawing No.7

■ Dimensions

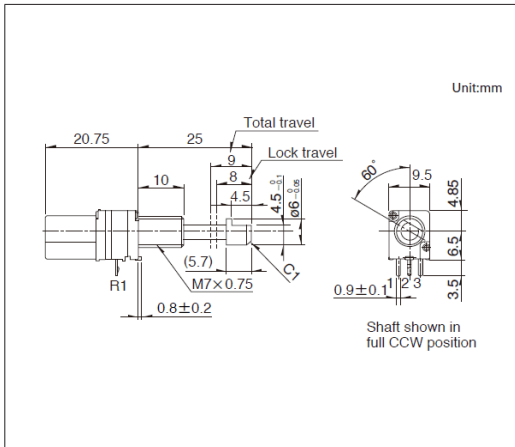

■ Mounting Hole Dimensions

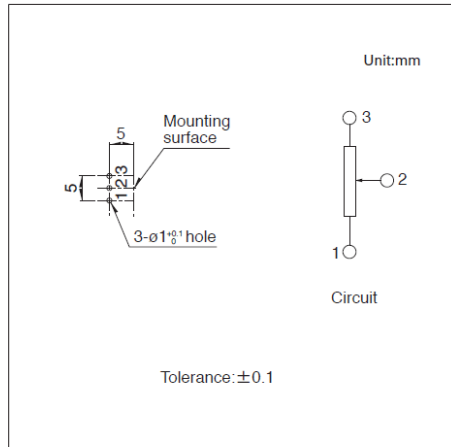

Viewed from mounting side.

Drawing No.8

■ Dimensions

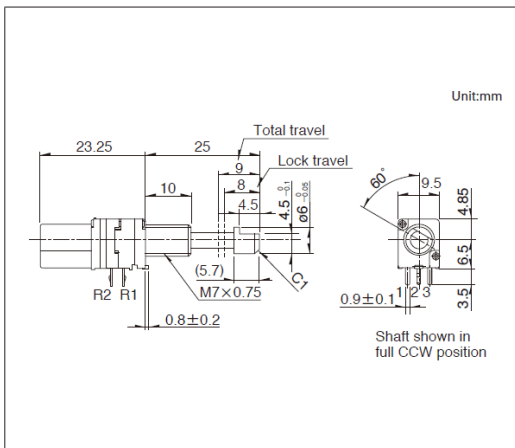

■ Mounting Hole Dimensions

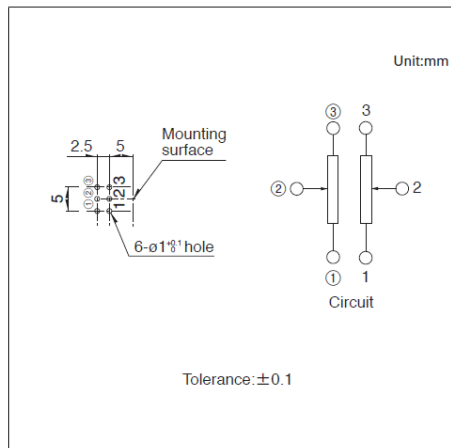

Viewed from mounting side.

Drawing No.9

■ Dimensions

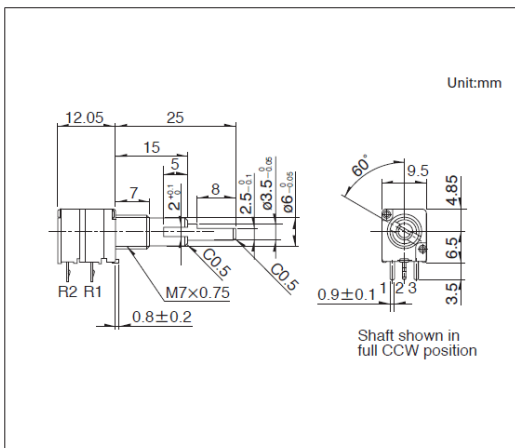

■ Mounting Hole Dimensions

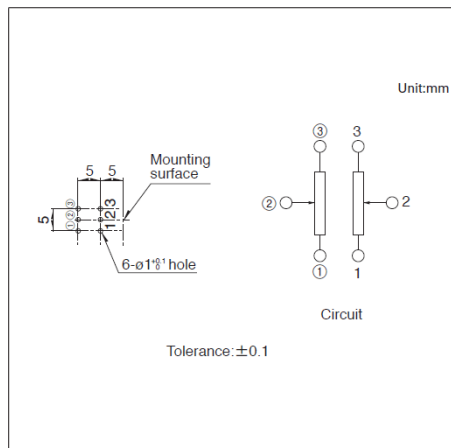

Viewed from mounting side.

9mm Size Metal Shaft Multi-ganged Type / Switch Specifications

Switch type		Rotary switch	Momentary push switch
Contact arrangement		Single pole and single throw	Single pole and single throw
Travel		50° max.	0.5 $\begin{smallmatrix} +0.7 \\ -0.3 \end{smallmatrix}$ mm
Changeover force		50mN·m max.	4 \pm $\frac{1}{2}$ N
Operating life under load		10,000 cycles	
Electrical performance	Rating	3A 16V DC (10mA 16V DC min. ratings)	0.5A 12V DC (10mA 12V DC min. ratings)
	Contact resistance	100mΩ max. for initial period, 200mΩ max. after operating life.	
	Insulation resistance	100MΩ min. 250V DC	
	Voltage proof	300V AC for 1 minute	

9mm Size Metal Shaft Multi-ganged Type / Attached Parts

The following parts are included with the product.

Unit:mm

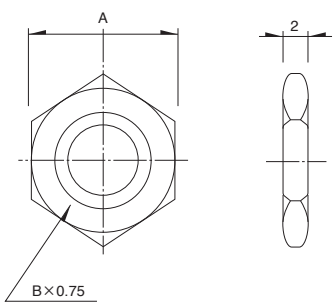
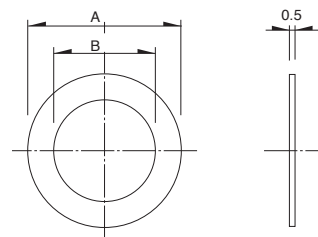
Nut			Washer		
					
Bearing screw diameter	Dimension		Bearing screw diameter	Dimension	
	A	B		A	B
M7	11	M7	M7	φ12	φ7.2
M9	11	M9	M9	φ14	φ9.1

Potentiometers Rotary Potentiometer (Metal shaft type)

16mm Size Metal Shaft Type RK163 Series

Versatile product specification variety supporting various control needs.

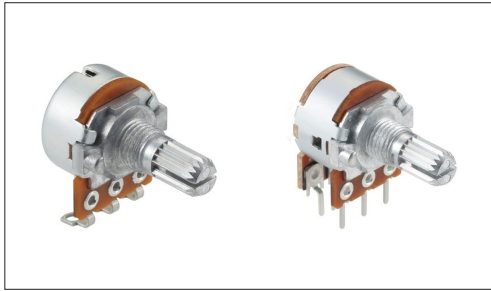

- Total resistance tolerance: $\pm 20\%$
- Maximum operating voltage: 150V AC, 5V DC
- Rotational torque: 3 to 25mN·m
- Operating life: 15,000 cycles
- Operating temperature range: -10°C to $+70^{\circ}\text{C}$

Applications: Home: Major home appliances, Office equipment
Audio_TV: Audio

■ Product List

Products No.	Number of resistor elements	Control part orientation	Shaft types	Length of the shaft (mm)	Detent	Total resistance	Resistance taper	Automotive	Drawing No.
RK1631110U1Q	Single-unit	Horizontal	Flat	20	Without	10k Ω	1B	—	1
RK1631110TNP	Single-unit	Horizontal	Flat	20	Without	10k Ω	1B	—	2
RK1631110U2A	Single-unit	Horizontal	Serrated	15	Without	10k Ω	1B	—	3
RK1631110U0Q	Single-unit	Horizontal	Serrated	15	Without	10k Ω	1B	—	4
RK16312101A2	Dual-unit	Horizontal	Flat	20	Center detent	10k Ω	1B	—	5
RK1631210AX9	Dual-unit	Horizontal	Serrated	15	Without	10k Ω	1B	—	6
RK16312A0B85	Dual-unit	Horizontal	Flat	20	Without	10k Ω	15A	—	5
RK16312A0BKR	Dual-unit	Horizontal	Serrated	15	Without	10k Ω	15A	—	6

⚠ Note

1. This catalog shows only outline specifications. When using the products, please obtain formal specifications for supply.
2. Please place purchase orders per minimum order unit (integer).
3. Products other than those listed in above products are also available. Please contact us for details.

■ Packing Specifications

Bulk

Products No.	Number of packages (pcs.)		Export package measurements (mm)
	1 case / Japan	1 case / export packing	
RK1631110U1Q RK1631110U2A RK16312101A2 RK1631210AX9 RK16312A0B85 RK16312A0BKR	600	1,200	532 x 326 x 386
RK1631110TNP RK1631110U0Q	200	400	360 x 270 x 155

16mm Size Metal Shaft Type
RK163 Series

Drawing No.1

■ Dimensions

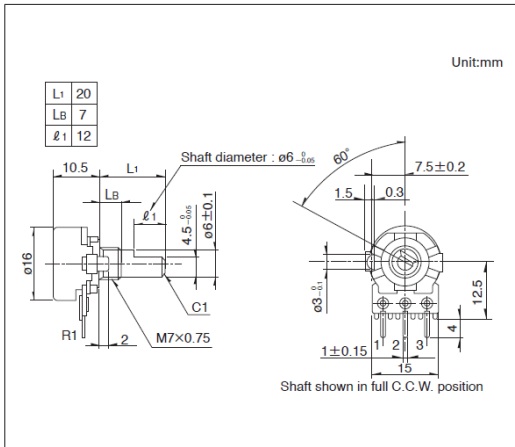

■ Mounting Hole Dimensions

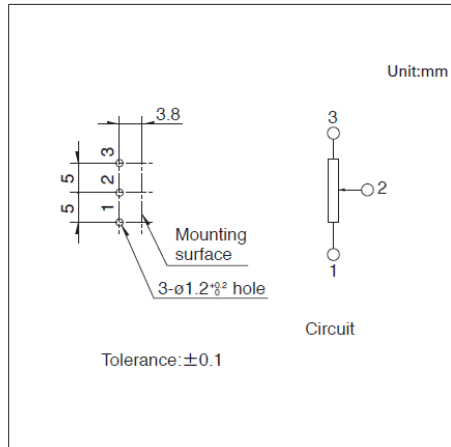

Viewed from mounting side.

Drawing No.2

■ Dimensions

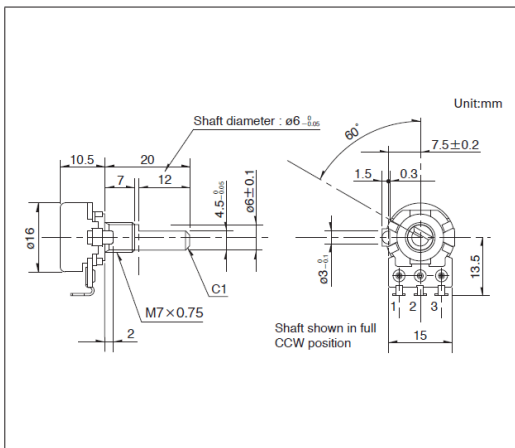

Drawing No.3

■ Dimensions

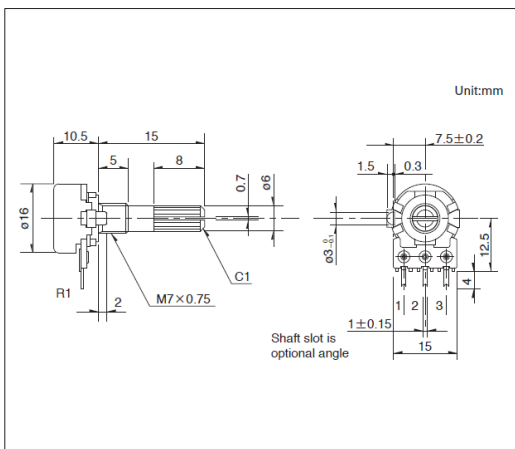

■ Mounting Hole Dimensions

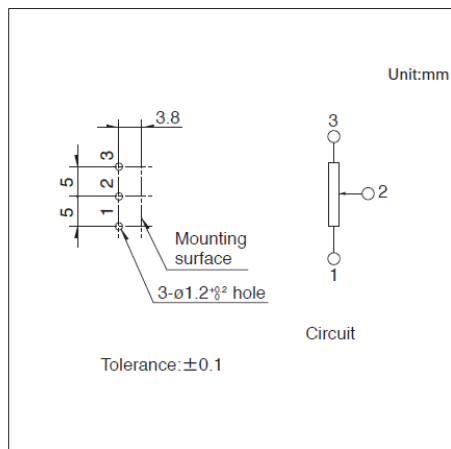

Viewed from mounting side.

16mm Size Metal Shaft Type
RK163 Series

Drawing No.4

■ Dimensions

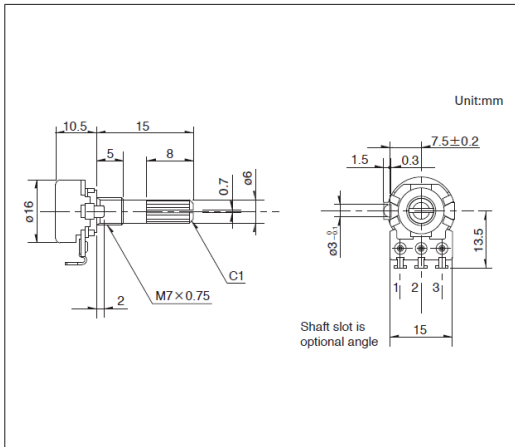

Drawing No.5

■ Dimensions

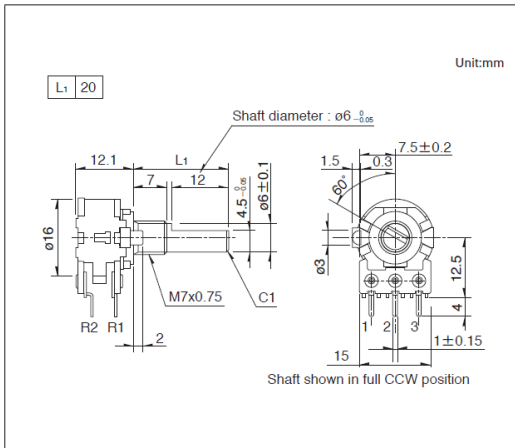

■ Mounting Hole Dimensions

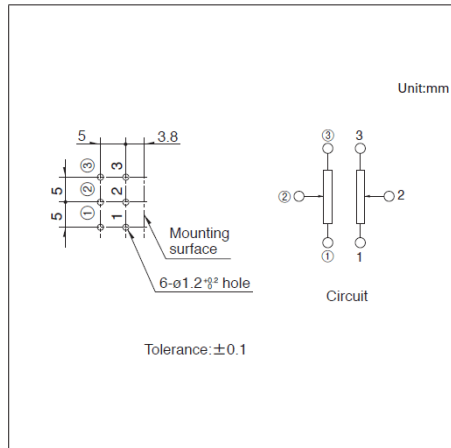

Viewed from mounting side.

Drawing No.6

■ Dimensions

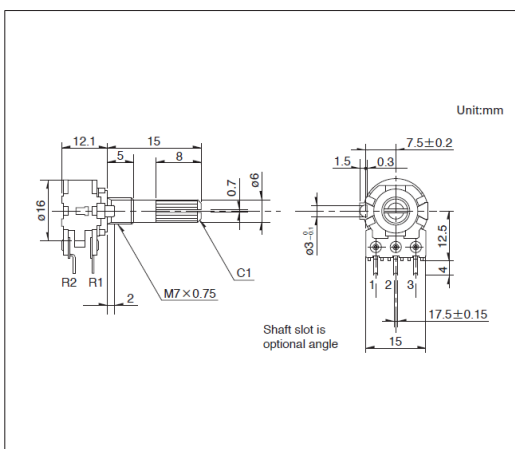

■ Mounting Hole Dimensions

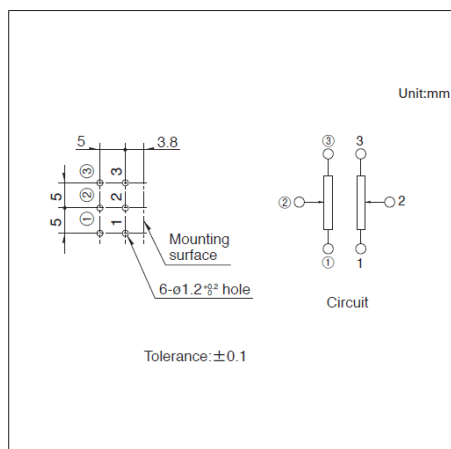

Viewed from mounting side.

16mm Size Metal Shaft Type / Attached Parts

The following parts are included with the product.

Unit:mm

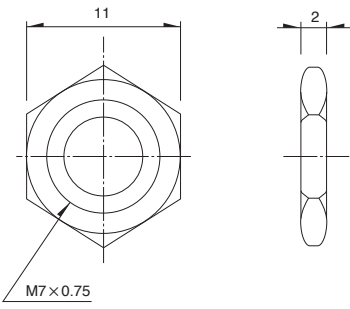
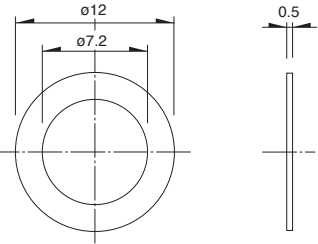
Nut	Washer
 <p>11</p> <p>2</p> <p>M7×0.75</p>	 <p>ø12</p> <p>ø7.2</p> <p>0.5</p>

Potentiometers Rotary Potentiometer (Metal shaft type)

27mm Size Metal Shaft Type RK271 Series

High-performance volume with excellent operation feel.

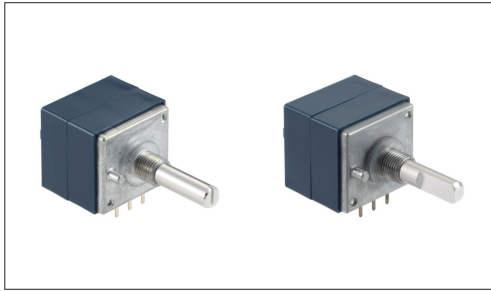

- Total resistance tolerance: $\pm 20\%$
- Maximum operating voltage: 30V AC
- Rotational torque: 8 to 35mN·m
- Operating life: 15,000 cycles
- Operating temperature range: -10°C to $+70^{\circ}\text{C}$

Applications: Audio_TV:Audio

■ Product List

Products No.	Number of resistor elements	Control part orientation	Shaft types	Length of the shaft (mm)	Detent	Total resistance	Resistance taper	Automotive	Drawing No.
RK2711120026	Single-unit	Horizontal	Slotted	25	31-position	100k Ω	15A	—	1
RK271111001T	Single-unit	Horizontal	Slotted	25	Without	100k Ω	15A	—	
RK27112A00AK	Dual-unit	Horizontal	Slotted	20	Without	100k Ω	15A	—	2
RK27112A00CC	Dual-unit	Horizontal	Slotted	25	Without	100k Ω	15A	—	3
RK27112A0A16	Dual-unit	Horizontal	Flat	20	Without	100k Ω	15A	—	4
RK27112A00B9	Dual-unit	Horizontal	Flat	25	Without	100k Ω	15A	—	5

⚠ Note

1. This catalog shows only outline specifications. When using the products, please obtain formal specifications for supply.
2. Please place purchase orders per minimum order unit (integer).
3. Products other than those listed in above products are also available. Please contact us for details.

■ Packing Specifications

Bulk

Products No.	Number of packages(pcs.)		Export package measurements (mm)
	1 case / Japan	1 case / export packing	
RK2711120026 RK271111001T RK27112A00AK RK27112A0A16	100	500	540 x 380 x 314
RK27112A00CC RK27112A00B9	100	500	510 x 360 x 359

27mm Size Metal Shaft Type
RK271 Series

Drawing No.1

■ Dimensions

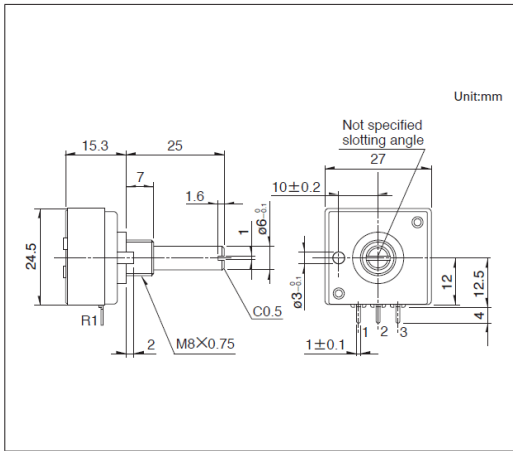

■ Mounting Hole Dimensions

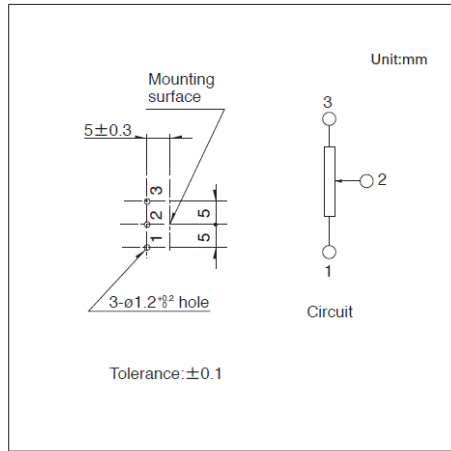

Viewed from mounting side.

Drawing No.2

■ Dimensions

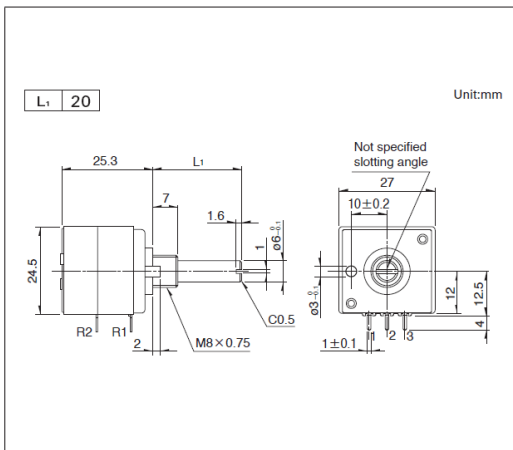

■ Mounting Hole Dimensions

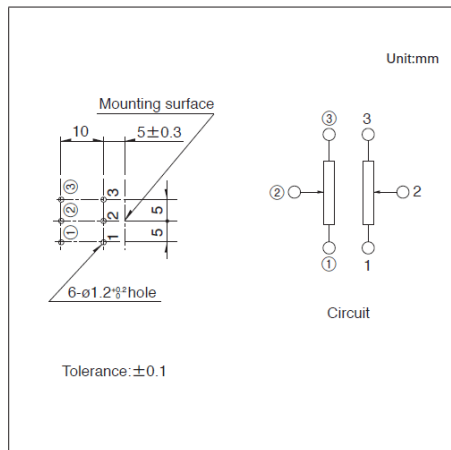

Viewed from mounting side.

Drawing No.3

■ Dimensions

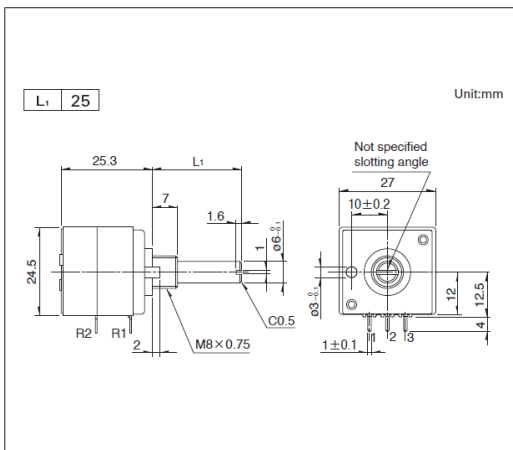

■ Mounting Hole Dimensions

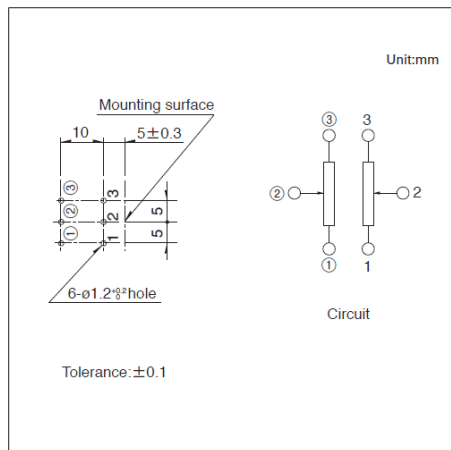

Viewed from mounting side.

27mm Size Metal Shaft Type
RK271 Series

Drawing No.4

■ Dimensions

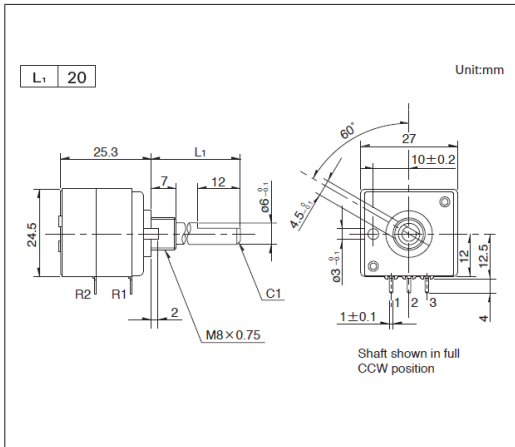

■ Mounting Hole Dimensions

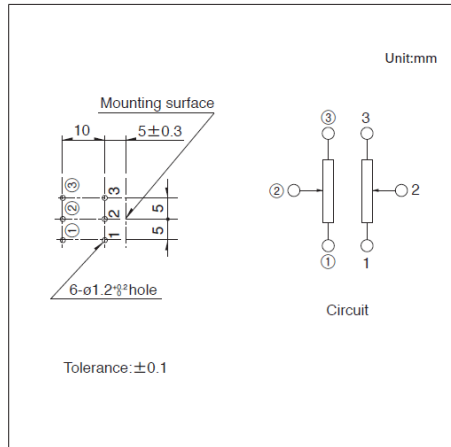

Viewed from mounting side.

Drawing No.5

■ Dimensions

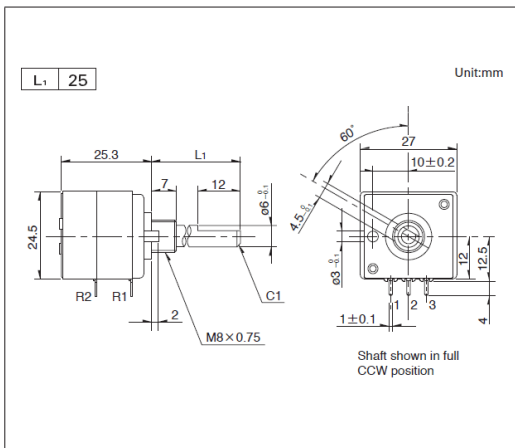

■ Mounting Hole Dimensions

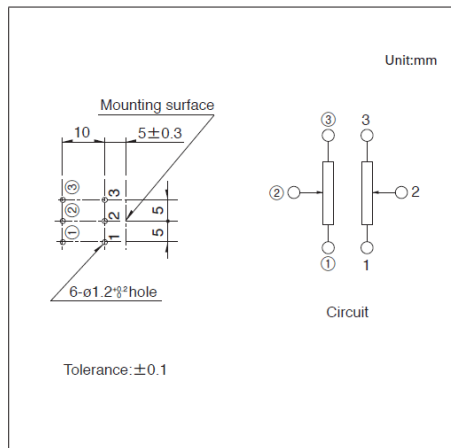

Viewed from mounting side.

27mm Size Metal Shaft Type / Attached Parts

The following parts are included with the product.

Unit:mm

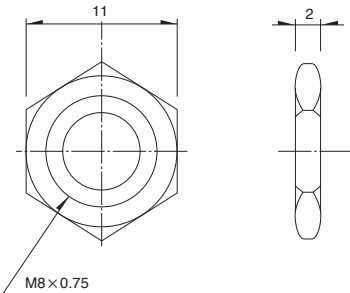
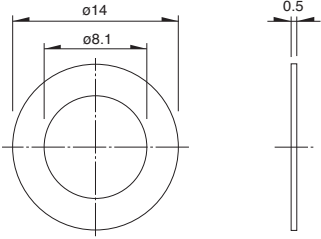
Nut	Washer
 <p>11</p> <p>2</p> <p>M8x0.75</p>	 <p>14</p> <p>8.1</p> <p>0.5</p>

Rotary Potentiometer (Metal shaft type) / Soldering Conditions

■ Reference for Manual Soldering

Series	Tip temperature	Soldering time	No. of solders
RK09L, RK097	350°C max.	3s max.	1 time
RK163, RK271	350°C max.	5s max.	1 time





■ Reference for Dip Soldering

Series	Preheating		Dip soldering		No. of solders
	Soldering surface temperature	Heating time	Soldering temperature	Soldering time	
RK09L, RK097	100°C max.	2 min. max.	260±5°C	5±1s	2 times max.

Potentiometers

Rotary Potentiometer (Insulated shaft type)

List of Varieties

Series		RK09K/RK09D	RK09Y11L	RK11K	RK12L	RK14K
Photo						
Dimensions		9mm Size		11mm Size	12mm Size	14mm Size
Control part orientation	Horizontal	●	●	●	●	●
	Vertical	●	—	●	●	●
Number of resistor elements		Single-unit			Dual-unit	
Shaft types		Driver Flat Knob	Flat			
Length of the shaft LM1 (mm)		15.0 20.0 25.0	—	22.5	25.0 30.0	22.5
Detent		Center detent Without	Without	Center detent Without		
Operating temperature range		-10°C to +70°C				
Operating life (cycles)		5,000	1,000,000	15,000		
Electrical performance	Total resistance	10kΩ				
	Resistance taper	1B	Linear	1B 15A		
	Total resistance tolerance	±20%	±30%	±20%		
	Rated power	0.05W	0.01W	0.05W		
	Maximum operating voltage	50V AC, 20V DC	50V AC, 5V DC	50V AC, 20V DC	50V AC for AC only	
	Gang error	—				-40dB to 0dB 3dB max. Within 2dB at center
	Insulation resistance	100MΩ min. 250V DC		100MΩ min. 500V DC		100MΩ min. 250V DC
Voltage proof	250V AC for 1 minute		500V AC for 1 minute		300V AC for 1 minute	
Mechanical performance	Total rotational angle	280° ±5° 300° ±5°	300° ±5° (Effective electrical rotational angle 60° ±5°)	300° ±5°		
	Rotational torque	1 to 8mN·m	5mN·m max.	3 to 20mN·m	2 to 15mN·m	3 to 20mN·m
	Stopper strength	0.3N·m	—	0.6N·m	0.5N·m	0.6N·m
	Push-pull strength	50N max.	30N max.	80N max.		
	Vibration	10 to 55 to 10Hz/min., the amplitude is 1.5mm for all the frequencies, in the 3 direction of X, Y and Z and for 2 hours respectively				
Automotive		—	—	—	—	—

⚠ Note

● Indicates applicability to all products in the series, while ○ indicates applicability to some products in the series.

Potentiometers Rotary Potentiometer (Insulated shaft type)

9mm Size Insulated Shaft Snap-in Type RK09K/RK09D Series

Compact type with a 9.8mm body width, supporting high-density set designs.



- Total resistance tolerance: $\pm 20\%$
- Maximum operating voltage: 50V AC, 20V DC
- Rotational torque: 1 to 8mN·m
- Operating life: 5,000 cycles
- Operating temperature range: -10°C to $+70^{\circ}\text{C}$

Applications: Home: Major home appliances, Office equipment
Audio_TV: Visual, Audio, Pro audio

Product List

Products No.	Type	Number of resistor elements	Control part orientation (Mounting height)	Shaft types	Length of the shaft LM1 (mm)	Detent	Total resistance	Resistance taper	Automotive	Drawing No.
RK09K113004U	—	Single-unit	Vertical	Flat	15.0	Center detent	10k Ω	1B	—	1
RK09K1130A6S		Single-unit	Vertical	Flat	15.0	Without	10k Ω	1B	—	
RK09K11300DR		Single-unit	Vertical	Knob	15.0	Center detent	10k Ω	1B	—	2
RK09K1130A8G		Single-unit	Vertical	Knob	15.0	Without	10k Ω	1B	—	
RK09K1130081		Single-unit	Vertical	Knob	20.0	Center detent	10k Ω	1B	—	3
RK09K1130A5R		Single-unit	Vertical	Knob	20.0	Without	10k Ω	1B	—	
RK09K1130AP5		Single-unit	Vertical	Driver	15.0	Without	10k Ω	1B	—	4
RK09K1130AST		Single-unit	Vertical	Driver	20.0	Without	10k Ω	1B	—	5
RK09K111009J		Single-unit	Horizontal	Flat	15.0	Center detent	10k Ω	1B	—	6
RK09K1110AK4		Single-unit	Horizontal	Flat	15.0	Without	10k Ω	1B	—	
RK09K11100DN		Single-unit	Horizontal	Flat	20.0	Center detent	10k Ω	1B	—	7
RK09K1110AAR		Single-unit	Horizontal	Flat	20.0	Without	10k Ω	1B	—	
RK09K1110077		Single-unit	Horizontal	Knob	20.0	Center detent	10k Ω	1B	—	8
RK09K1110A0J		Single-unit	Horizontal	Knob	20.0	Without	10k Ω	1B	—	
RK09K1110AMJ		Single-unit	Horizontal	Flat	15.0	Without	10k Ω	1B	—	9
RK09K1110B26		Single-unit	Horizontal	Flat	20.0	Without	10k Ω	1B	—	10
RK09D1130C3W		Single-unit	Vertical	Flat	20.0	Center detent	10k Ω	1B	—	11
RK09D1130C1B		Single-unit	Vertical	Flat	20.0	Without	10k Ω	1B	—	
RK09D1130C3C		Single-unit	Vertical	Flat	25.0	Center detent	10k Ω	1B	—	12
RK09D1130C2P		Single-unit	Vertical	Flat	25.0	Without	10k Ω	1B	—	
RK09D1110C1A	Single-unit	Horizontal	Flat	25.0	Without	10k Ω	1B	—	13	
RK09K1130D62	Clear-shaft	Single-unit	Vertical	Knob	20.0	Without	10k Ω	1B	—	14

⚠ Note

1. This catalog shows only outline specifications. When using the products, please obtain formal specifications for supply.
2. Please place purchase orders per minimum order unit (integer).
3. Products other than those listed in above products are also available. Please contact us for details.

Potentiometers Rotary Potentiometer (Insulated shaft type)

9mm Size Insulated Shaft Snap-in Type RK09K/RK09D Series

■ Packing Specifications

Bulk

Number of packages (pcs.)		Export package measurements (mm)
1 case / Japan	1 case / export packing	
1,000	2,000	528 x 369 x 178

Drawing No.1

■ Dimensions

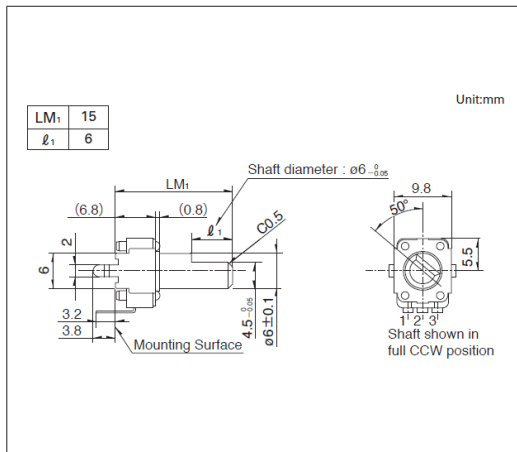

■ Mounting Hole Dimensions

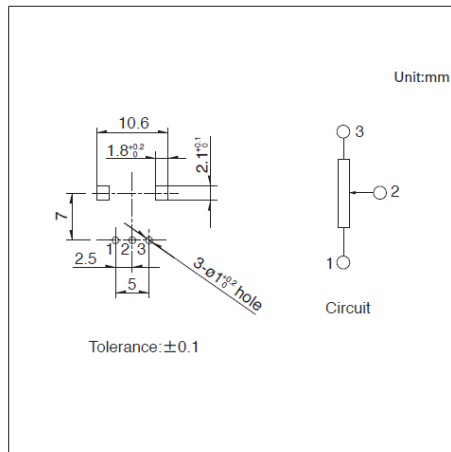

■ Terminal Layout / Circuit Diagram

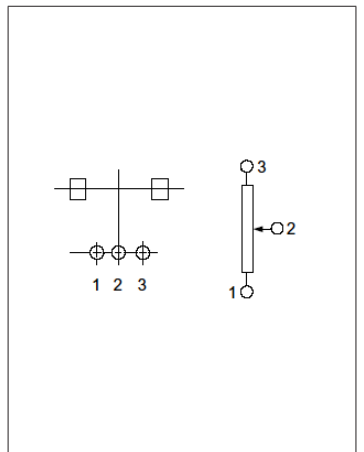

Viewed from mounting side.

Drawing No.2

■ Dimensions

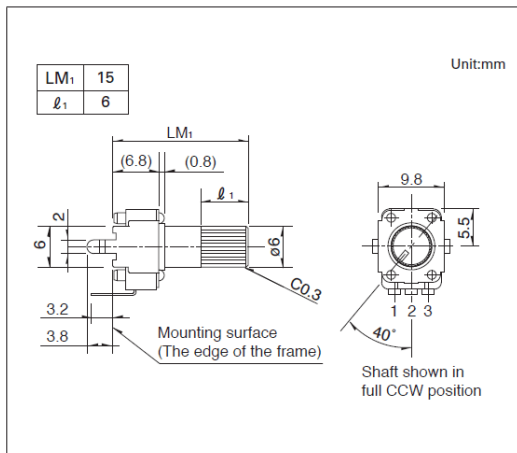

■ Mounting Hole Dimensions

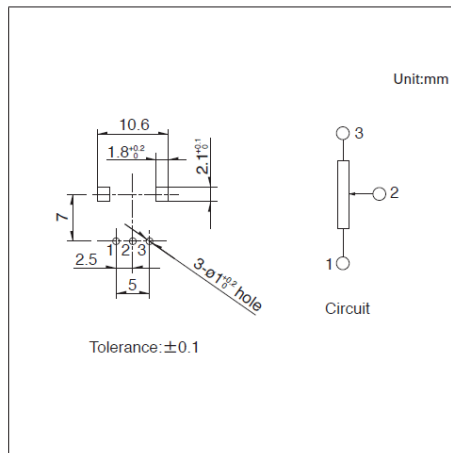

■ Terminal Layout / Circuit Diagram

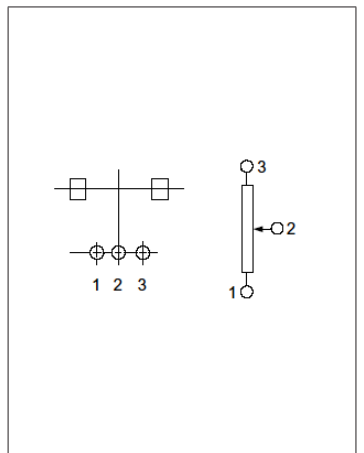

Viewed from mounting side.

Potentiometers Rotary Potentiometer (Insulated shaft type)

9mm Size Insulated Shaft Snap-in Type
RK09K/RK09D Series

Drawing No.3

■ Dimensions

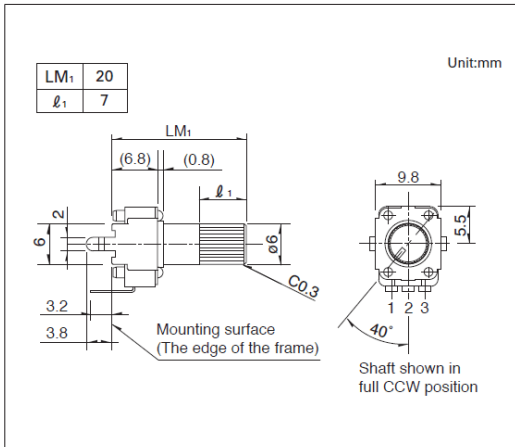

■ Mounting Hole Dimensions

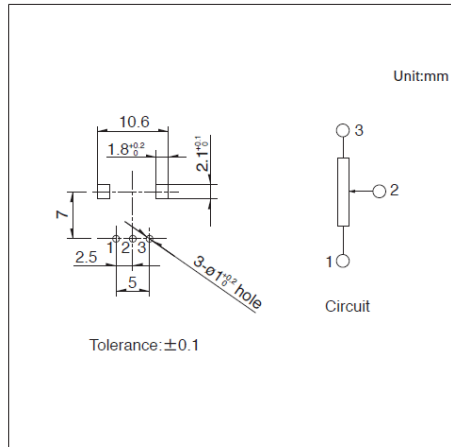

■ Terminal Layout / Circuit Diagram

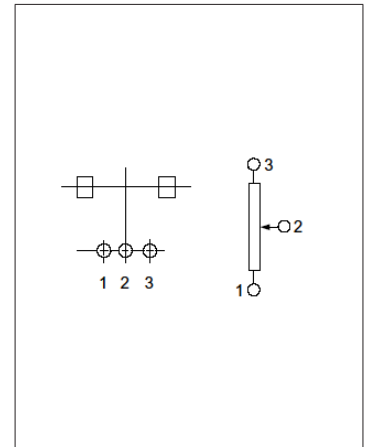

Viewed from mounting side.

Drawing No.4

■ Dimensions

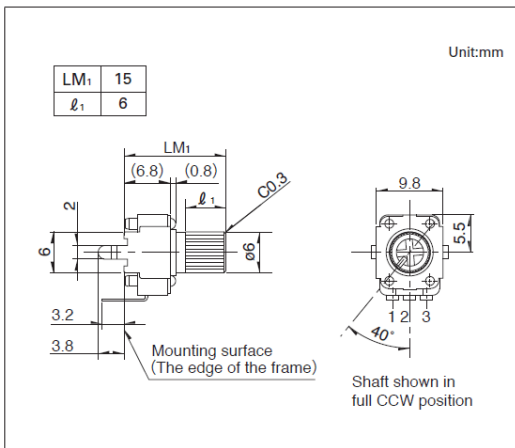

■ Mounting Hole Dimensions

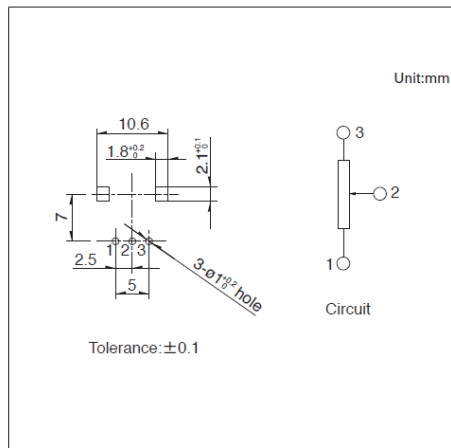

■ Terminal Layout / Circuit Diagram

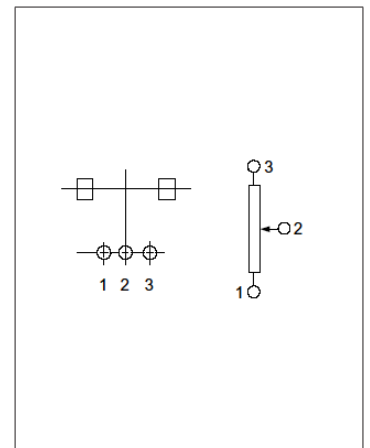

Viewed from mounting side.

Drawing No.5

■ Dimensions

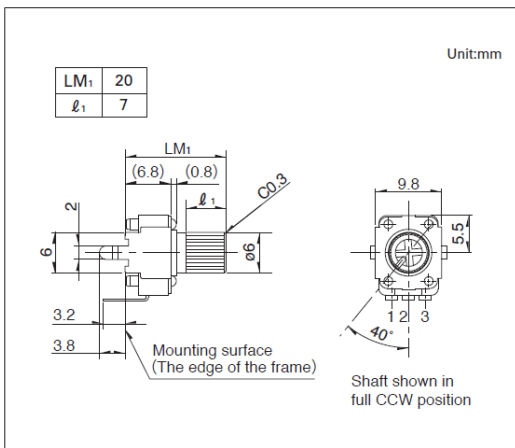

■ Mounting Hole Dimensions

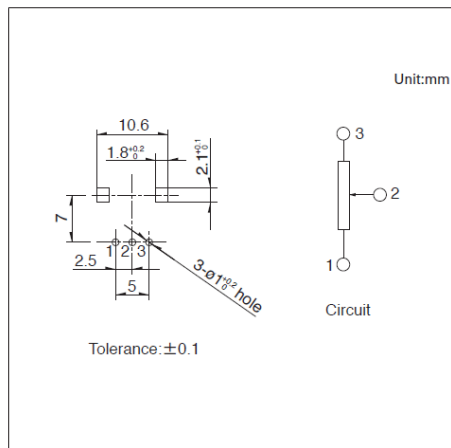

■ Terminal Layout / Circuit Diagram

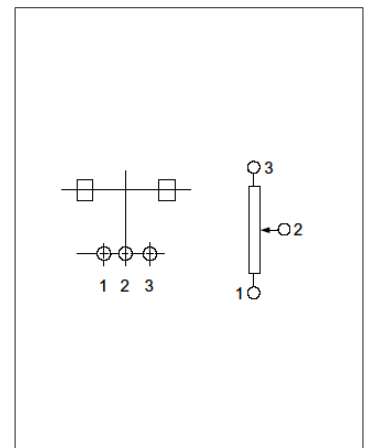

Viewed from mounting side.

9mm Size Insulated Shaft Snap-in Type
RK09K/RK09D Series

Drawing No.6

■ Dimensions

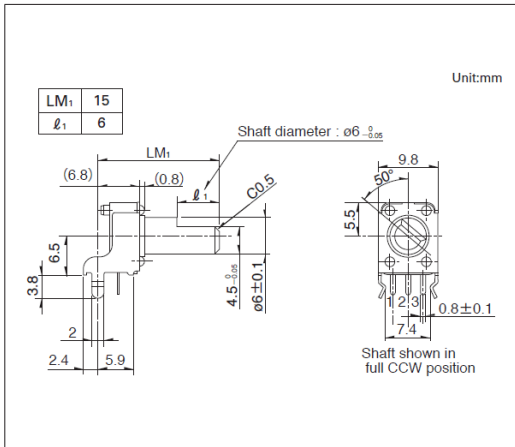

■ Mounting Hole Dimensions

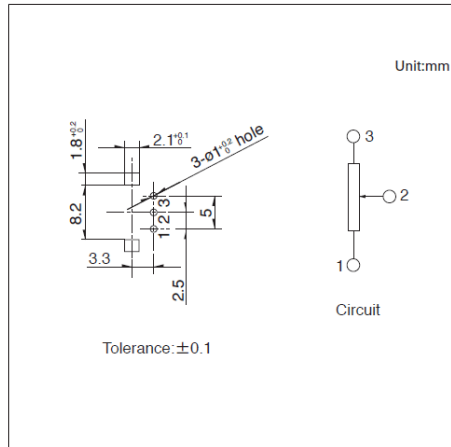

■ Terminal Layout / Circuit Diagram

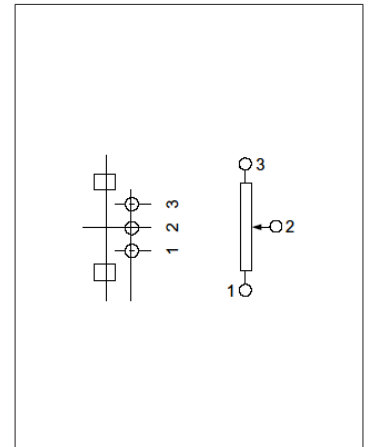

Viewed from mounting side.

Drawing No.7

■ Dimensions

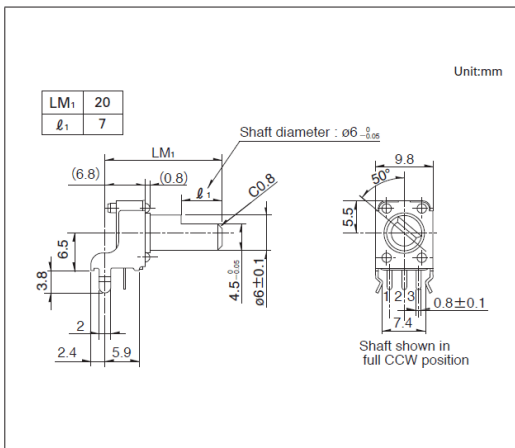

■ Mounting Hole Dimensions

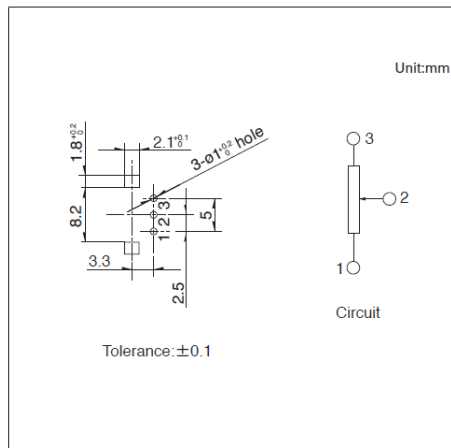

■ Terminal Layout / Circuit Diagram

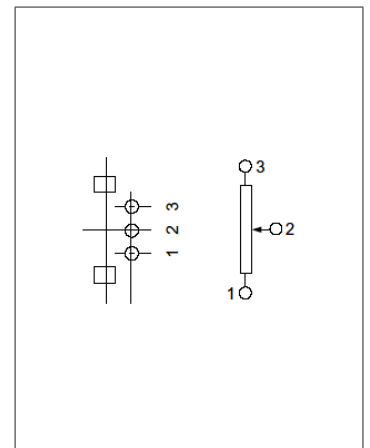

Viewed from mounting side.

Drawing No.8

■ Dimensions

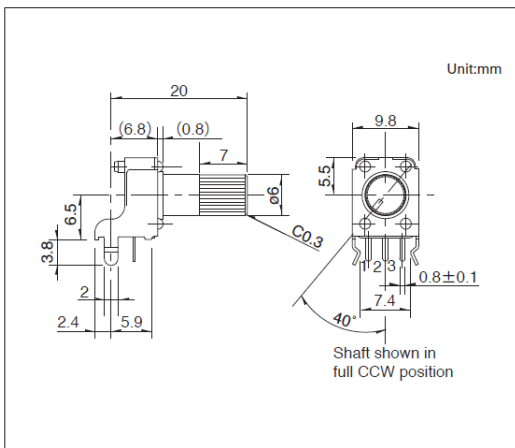

■ Mounting Hole Dimensions

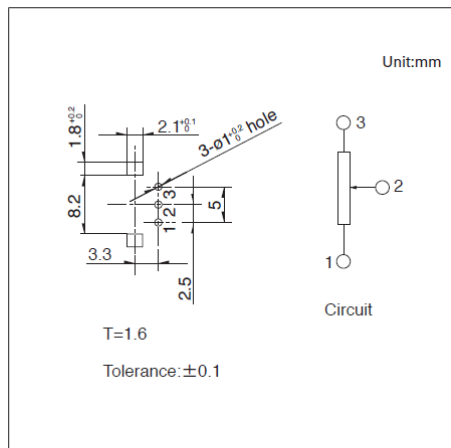

■ Terminal Layout / Circuit Diagram

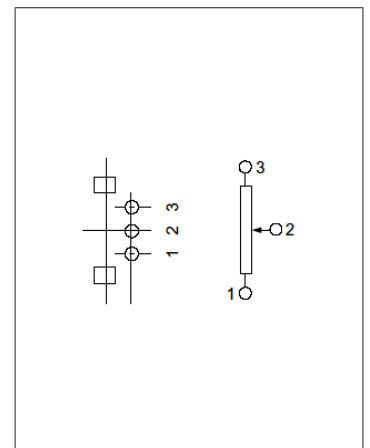

Viewed from mounting side.

9mm Size Insulated Shaft Snap-in Type
RK09K/RK09D Series

Drawing No.9

■ Dimensions

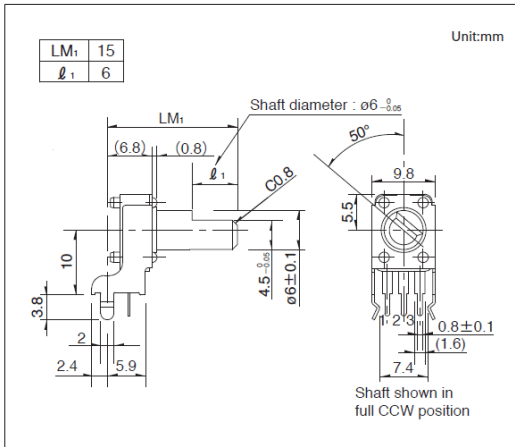

■ Mounting Hole Dimensions

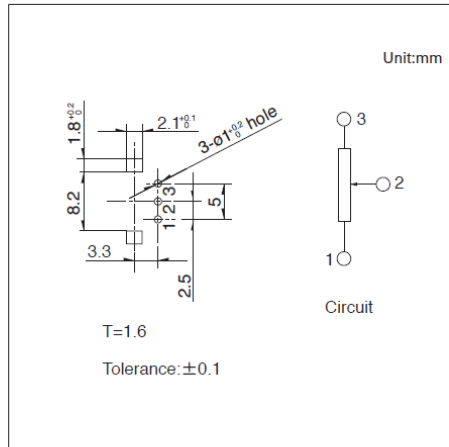

■ Terminal Layout / Circuit Diagram

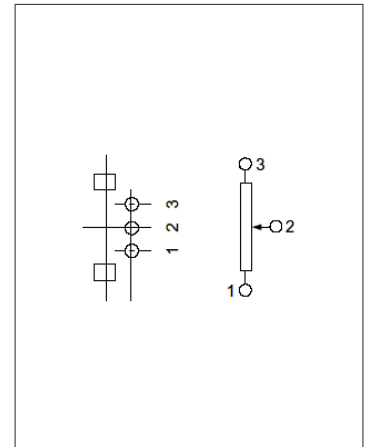

Viewed from mounting side.

Drawing No.10

■ Dimensions

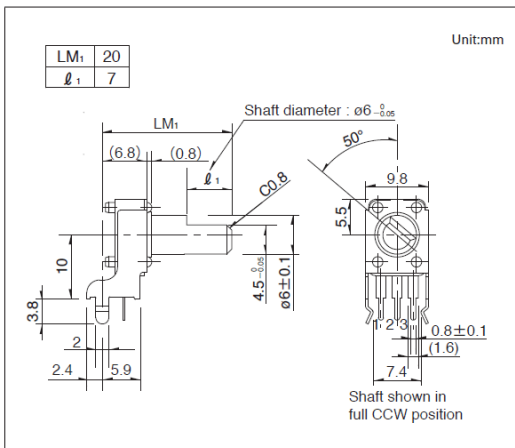

■ Mounting Hole Dimensions

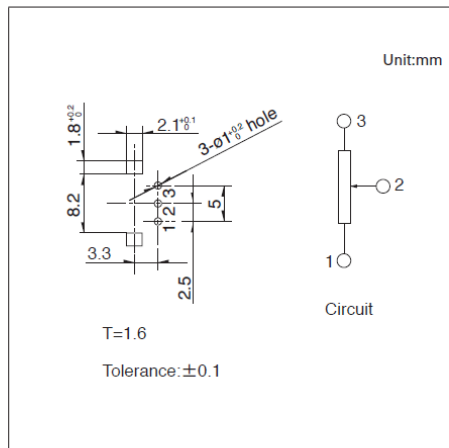

■ Terminal Layout / Circuit Diagram

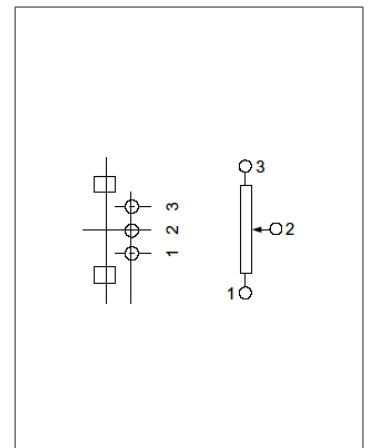

Viewed from mounting side.

Drawing No.11

■ Dimensions

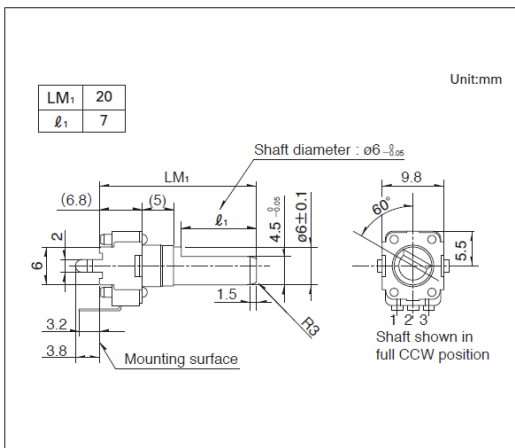

■ Mounting Hole Dimensions

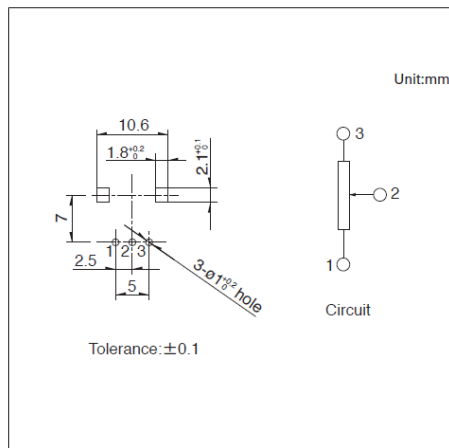

■ Terminal Layout / Circuit Diagram

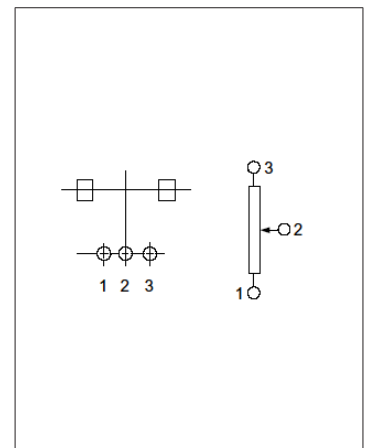

Viewed from mounting side.

9mm Size Insulated Shaft Snap-in Type
RK09K/RK09D Series

Drawing No.12

■ Dimensions

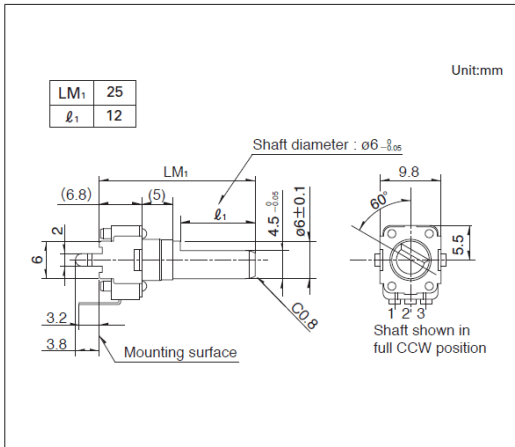

■ Mounting Hole Dimensions

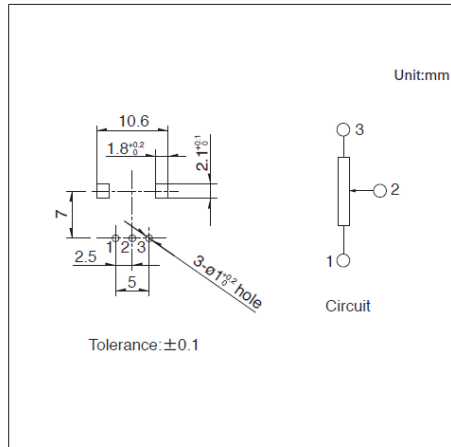

■ Terminal Layout / Circuit Diagram

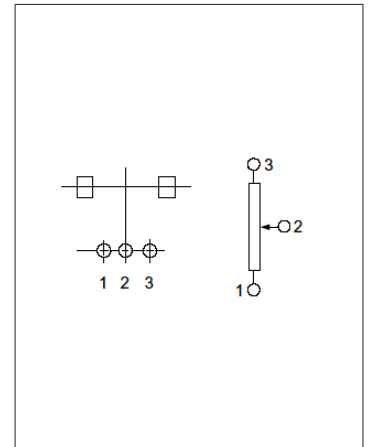

Viewed from mounting side.

Drawing No.13

■ Dimensions

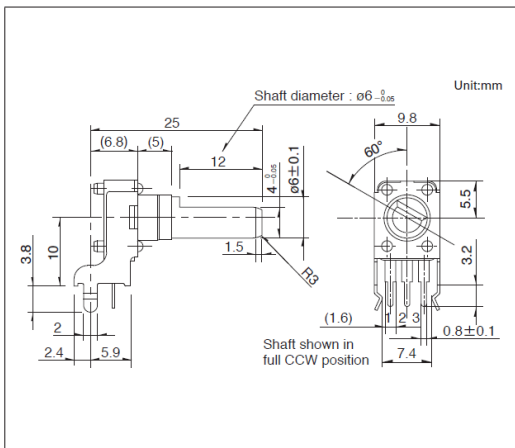

■ Mounting Hole Dimensions

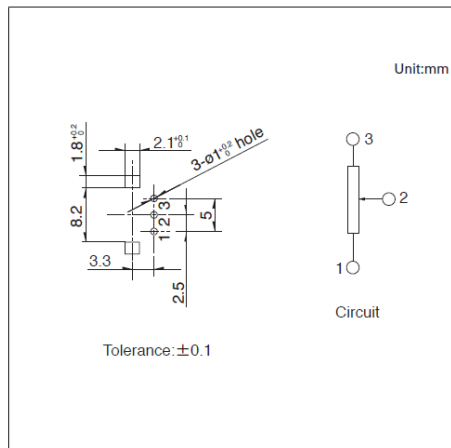

■ Terminal Layout / Circuit Diagram

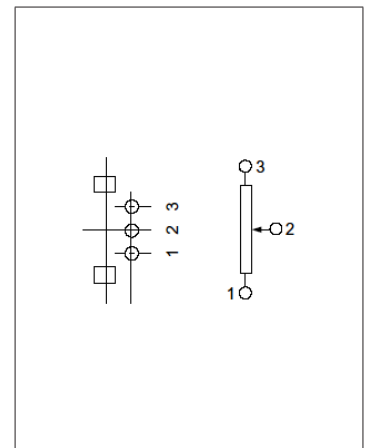

Viewed from mounting side.

Drawing No.14

■ Dimensions

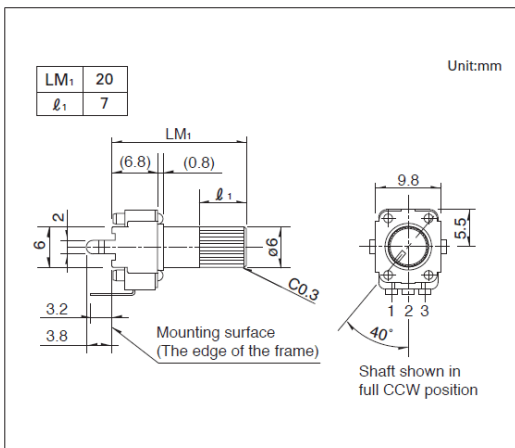

■ Mounting Hole Dimensions

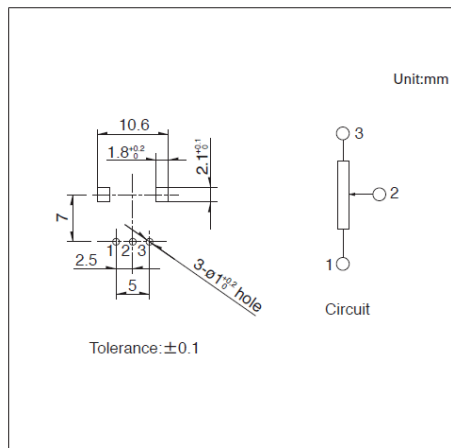

■ Terminal Layout / Circuit Diagram

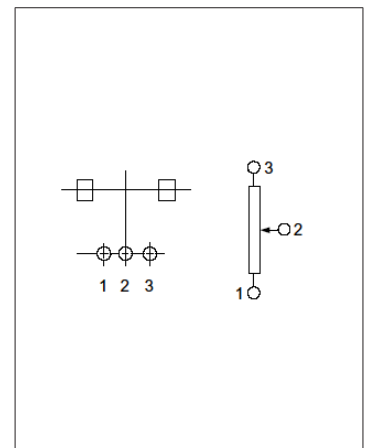

Viewed from mounting side.

Potentiometers Rotary Potentiometer (Insulated shaft type)

9mm Size Insulated Shaft Long-life Type RK09Y1 1L Series

Compact design with a rotational life of 1 million cycles.



- Total resistance tolerance: ±30%
- Maximum operating voltage: 50V AC, 5V DC
- Rotational torque: 5mN·m max.
- Operating life: 1,000,000 cycles
- Operating temperature range: -10°C to +70°C

Applications: Game: Home handheld consoles, Virtual/augmented reality

■ Product List

Products No.	Number of resistor elements	Control part orientation	Shaft types	Length of the shaft	Detent	Total resistance	Resistance taper	Automotive	Drawing No.
RK09Y11L0001	Single-unit	Horizontal	Flat	12.0mm	Without	10kΩ	Linear	—	1

Note

1. This catalog shows only outline specifications. When using the products, please obtain formal specifications for supply.
2. Please place purchase orders per minimum order unit (integer).

■ Packing Specifications

Bulk

Number of packages (pcs.)		Export package measurements (mm)
1 case / Japan	1 case / export packing	
3,500	7,000	528 x 369 x 178

Drawing No. 1

■ Dimensions

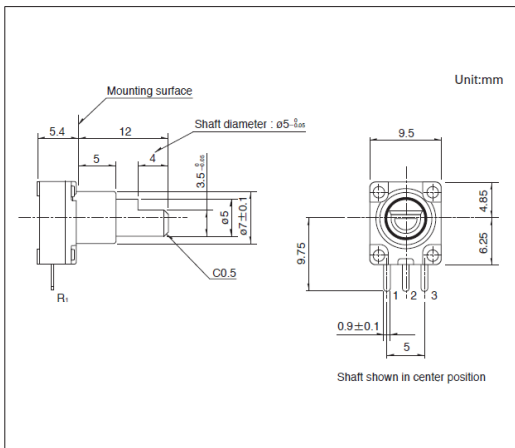

■ Mounting Hole Dimensions

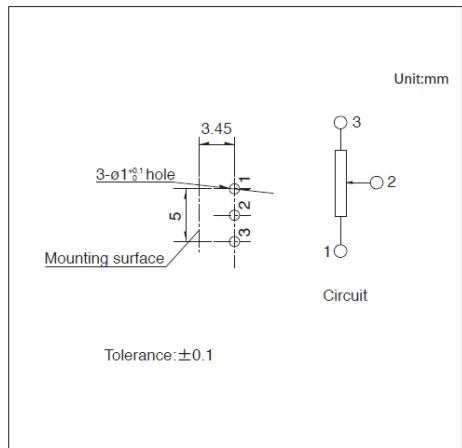

Viewed from mounting side.

Potentiometers Rotary Potentiometer (Insulated shaft type)

1 1mm Size Insulated Shaft Snap-in Type
RK1 1K Series

Body width of 1 1mm, widely compatible with audio, video, and electronic musical instruments.

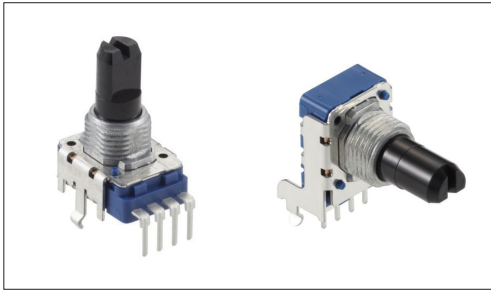

- Total resistance tolerance: ±20%
- Maximum operating voltage: 50V AC, 20V DC
- Rotational torque: 3 to 20mN·m
- Operating life: 15,000 cycles
- Operating temperature range: -10°C to +70°C

Applications: Home: Major home appliances, Office equipment
 Audio_TV: Visual, Audio, Pro audio

■ Product List

Products No.	Number of resistor elements	Control part orientation	Shaft types	Length of the shaft LM1 (mm)	Detent	Total resistance	Resistance taper	Automotive	Drawing No.
RK11K1140AHZ	Single-unit	Vertical	Flat	22.5	Without	10kΩ	15A	—	1
RK11K1140097	Single-unit	Vertical	Flat	22.5	Center detent	10kΩ	1B	—	
RK11K1120A13	Single-unit	Horizontal	Flat	22.5	Without	10kΩ	15A	—	2
RK11K112000P	Single-unit	Horizontal	Flat	22.5	Center detent	10kΩ	1B	—	

Note

1. This catalog shows only outline specifications. When using the products, please obtain formal specifications for supply.
2. Please place purchase orders per minimum order unit (integer).
3. Products other than those listed in above products are also available. Please contact us for details.
4. Nut and washer are not attached. Please specify if required.

■ Packing Specifications

Tray

Number of packages (pcs.)		Export package measurements (mm)
1 case / Japan	1 case / export packing	
1,000	2,000	543 x 377 x 250

Drawing No. 1

■ Dimensions

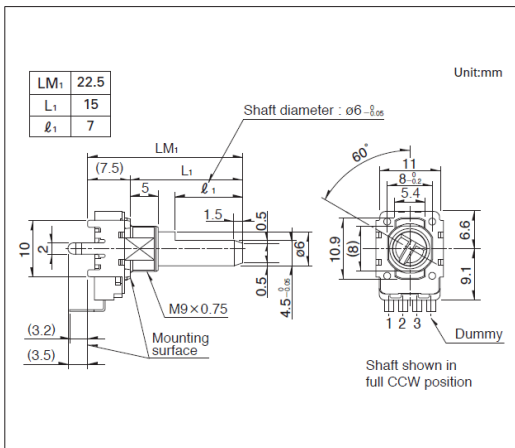

■ Mounting Hole Dimensions

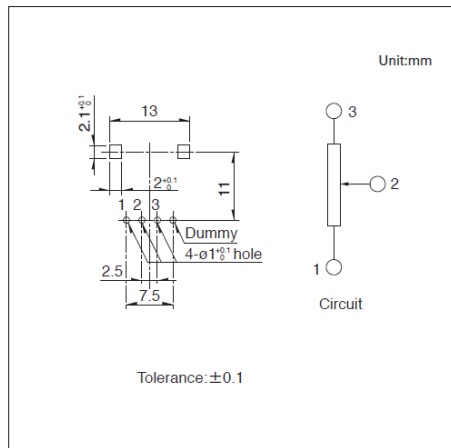

■ Terminal Layout / Circuit Diagram

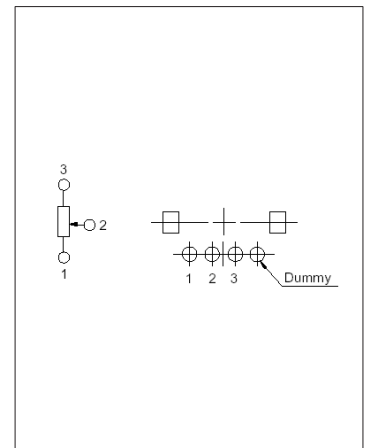

Viewed from mounting side.

11 mm Size Insulated Shaft Snap-in Type
RK11K Series

Drawing No.2

■ Dimensions

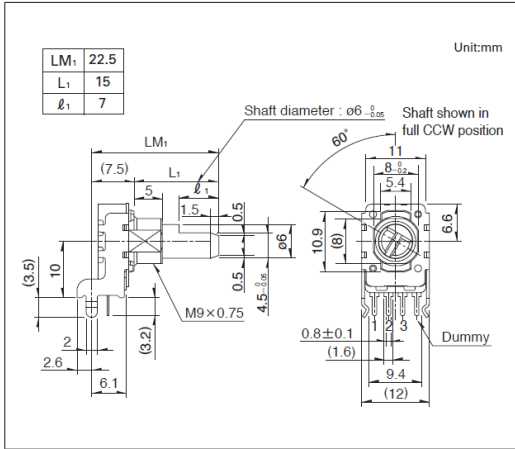

■ Mounting Hole Dimensions

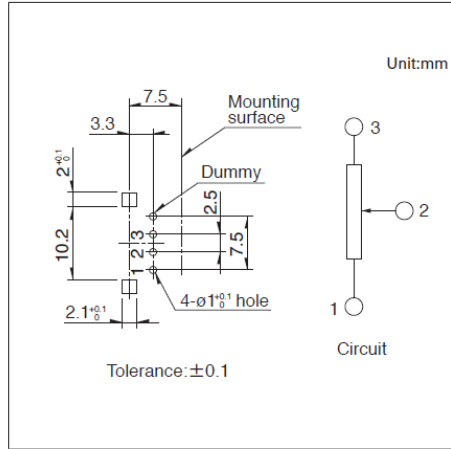

■ Terminal Layout / Circuit Diagram

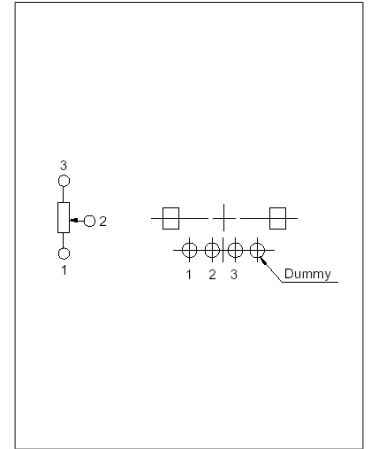

Viewed from mounting side.

Potentiometers Rotary Potentiometer (Insulated shaft type)

12mm Size Insulated Shaft Snap-in Type RK12L Series

Body width of 12mm, delivering high performance.

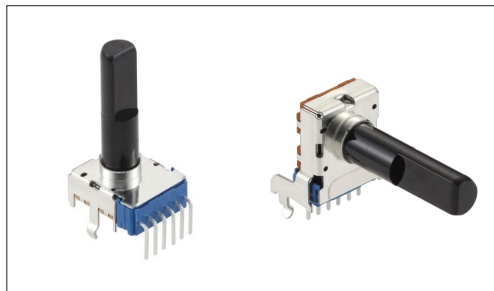

- Total resistance tolerance: $\pm 20\%$
- Maximum operating voltage: 50V AC for AC only
- Rotational torque: 2 to 15mN·m
- Operating life: 15,000 cycles
- Operating temperature range: -10°C to $+70^{\circ}\text{C}$

Applications: Home: Major home appliances, Office equipment
Audio_TV: Visual, Audio, Pro audio

■ Product List

Products No.	Number of resistor elements	Control part orientation	Shaft types	Length of the shaft LM1 (mm)	Detent	Total resistance	Resistance taper	Automotive	Drawing No.
RK12L1230C1K	Dual-unit	Vertical	Flat	25.0	Center detent	10k Ω	1B	—	1
RK12L1230C0Q	Dual-unit	Vertical	Flat	25.0	Without	10k Ω	1B	—	
RK12L123000G	Dual-unit	Vertical	Flat	30.0	Center detent	10k Ω	1B	—	2
RK12L1230A08	Dual-unit	Vertical	Flat	30.0	Without	10k Ω	1B	—	
RK12L1210C1T	Dual-unit	Horizontal	Flat	30.0	Center detent	10k Ω	1B	—	3
RK12L1210C0V	Dual-unit	Horizontal	Flat	30.0	Without	10k Ω	1B	—	
RK12L12C0A0E	Dual-unit	Vertical	Flat	25.0	Without	10k Ω	15A	—	1
RK12L12C0A0G	Dual-unit	Vertical	Flat	30.0	Without	10k Ω	15A	—	2
RK12L12A0C0R	Dual-unit	Horizontal	Flat	30.0	Without	10k Ω	15A	—	3

⚠ Note

1. This catalog shows only outline specifications. When using the products, please obtain formal specifications for supply.
2. Please place purchase orders per minimum order unit (integer).
3. Products other than those listed in above products are also available. Please contact us for details.

■ Packing Specifications

Tray

Number of packages (pcs.)		Export package measurements (mm)
1 case / Japan	1 case / export packing	
800	1,600	543 x 377 x 250

12mm Size Insulated Shaft Snap-in Type
RK12L Series

Drawing No.1

■ Dimensions

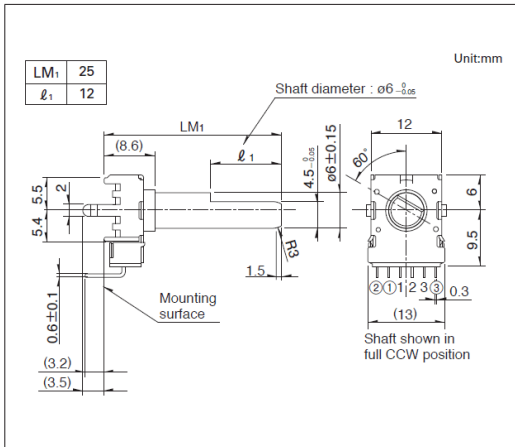

■ Mounting Hole Dimensions

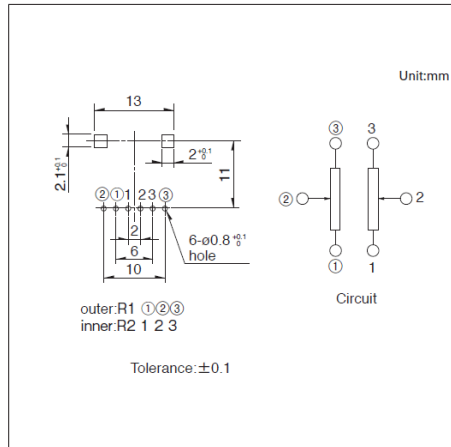

Viewed from mounting side.

Drawing No.2

■ Dimensions

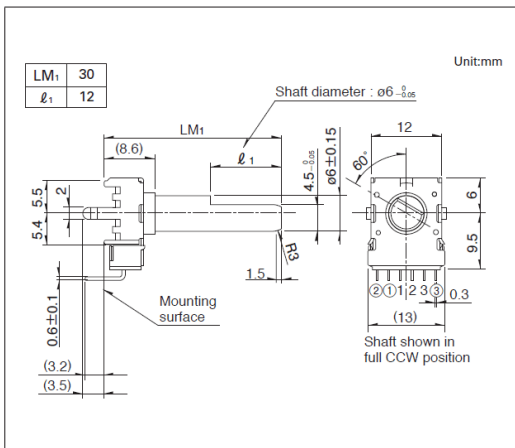

■ Mounting Hole Dimensions

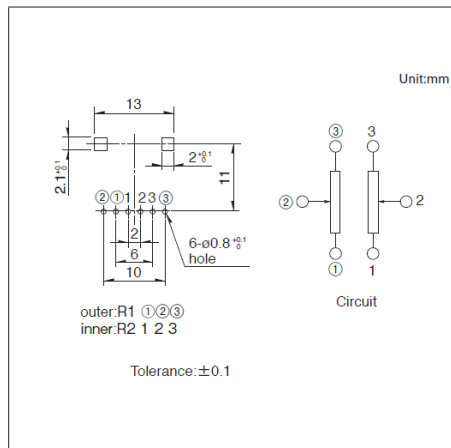

Viewed from mounting side.

Drawing No.3

■ Dimensions

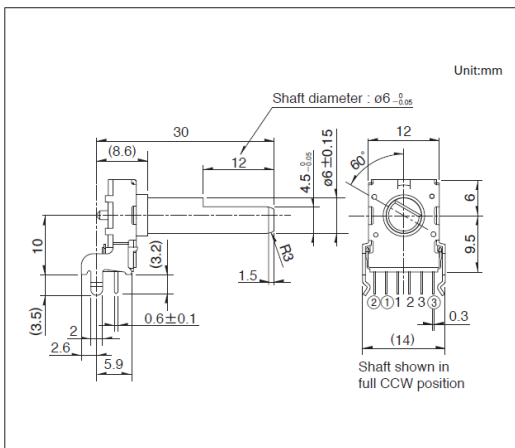

■ Mounting Hole Dimensions

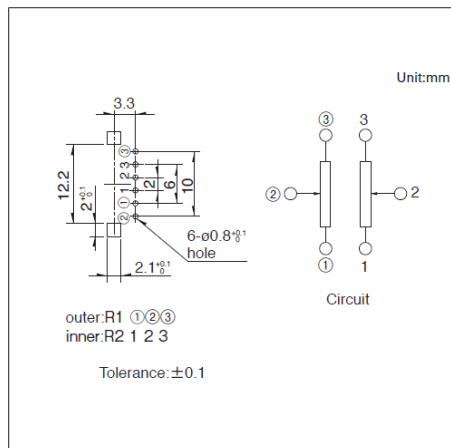

Viewed from mounting side.

Potentiometers Rotary Potentiometer (Insulated shaft type)

14mm Size Insulated Shaft Snap-in Type RK14K Series

Body width of 14mm, widely compatible with audio, video, and electronic musical instruments.

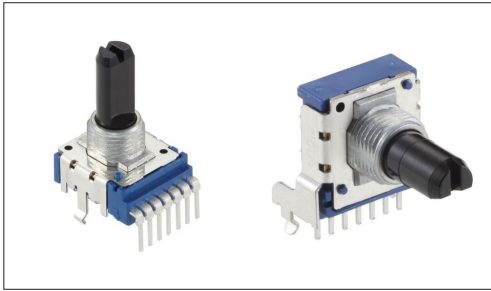

- Total resistance tolerance: ±20%
- Maximum operating voltage: 50V AC for AC only
- Rotational torque: 3 to 20mN·m
- Operating life: 15,000 cycles
- Operating temperature range: -10°C to +70°C

Applications: Home: Major home appliances, Office equipment
Audio_TV: Visual, Audio, Pro audio

■ Product List

Products No.	Number of resistor elements	Control part orientation	Shaft types	Length of the shaft LM1 (mm)	Detent	Total resistance	Resistance taper	Automotive	Drawing No.
RK14K124003H	Dual-unit	Vertical	Flat	22.5	Center detent	10kΩ	1B	—	1
RK14K1220012	Dual-unit	Horizontal	Flat	22.5	Center detent	10kΩ	1B	—	2
RK14K12D0A5V	Dual-unit	Vertical	Flat	22.5	Without	10kΩ	15A	—	3
RK14K12B0A0E	Dual-unit	Horizontal	Flat	22.5	Without	10kΩ	15A	—	4

Note

1. This catalog shows only outline specifications. When using the products, please obtain formal specifications for supply.
2. Please place purchase orders per minimum order unit (integer).
3. Products other than those listed in above products are also available. Please contact us for details.
4. Nut and washer are not attached. Please specify if required.

■ Packing Specifications

Tray

Number of packages (pcs.)		Export package measurements (mm)
1 case / Japan	1 case / export packing	
1,000	2,000	543 x 377 x 250

Drawing No. 1

■ Dimensions

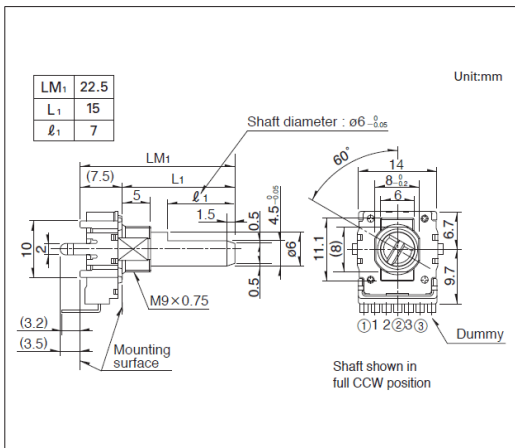

■ Mounting Hole Dimensions

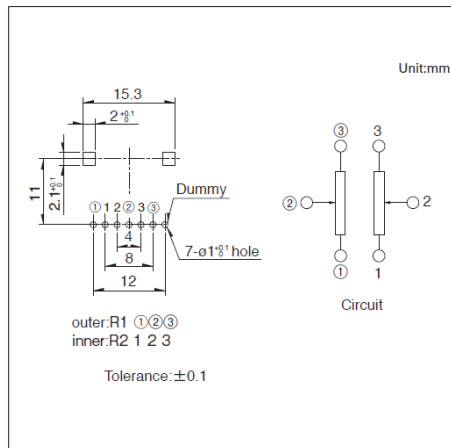

■ Terminal Layout / Circuit Diagram

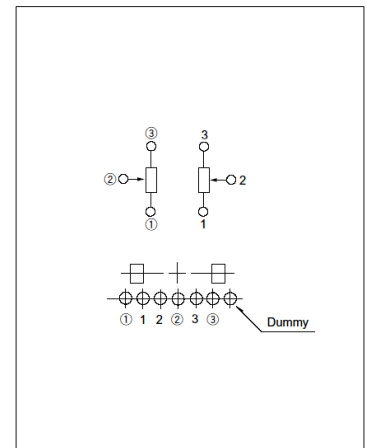

Viewed from mounting side.

14mm Size Insulated Shaft Snap-in Type
RK14K Series

Drawing No.2

■ Dimensions

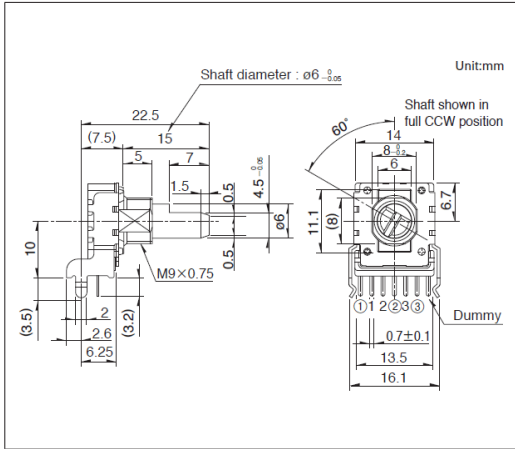

■ Mounting Hole Dimensions

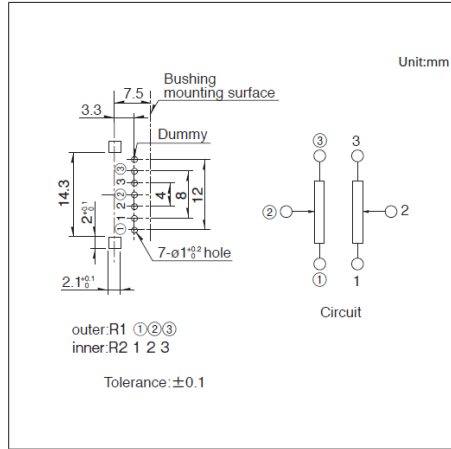

■ Terminal Layout / Circuit Diagram

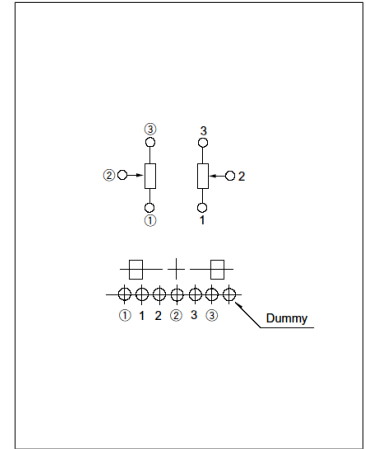

Viewed from mounting side.

Drawing No.3

■ Dimensions

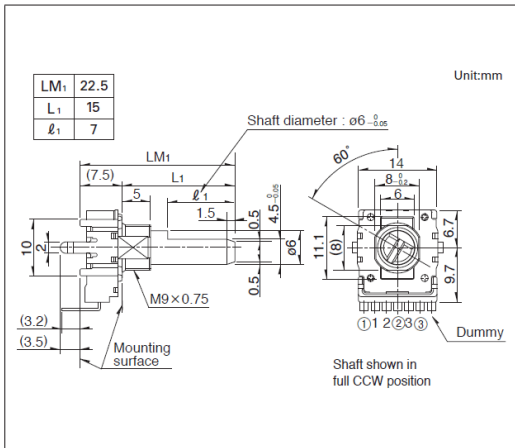

■ Mounting Hole Dimensions

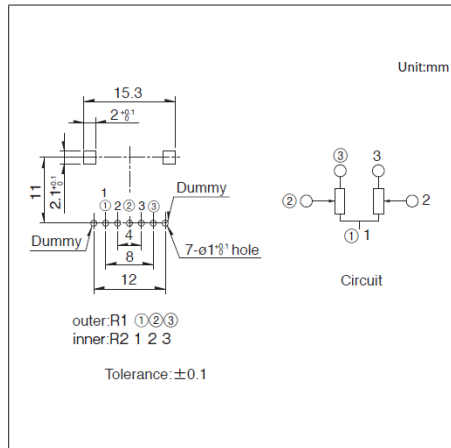

■ Terminal Layout / Circuit Diagram

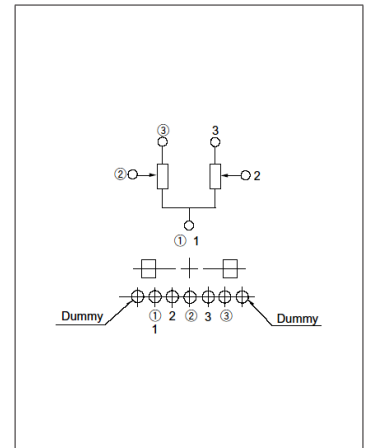

Viewed from mounting side.

Drawing No.4

■ Dimensions

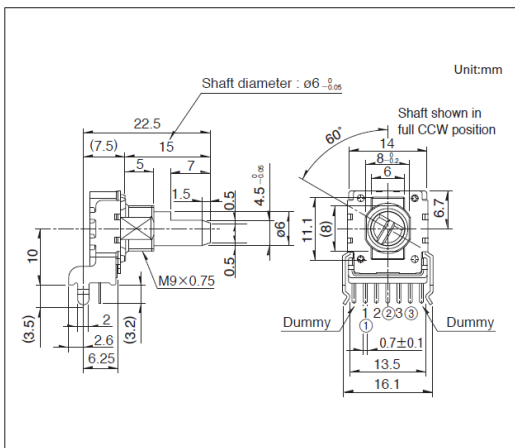

■ Mounting Hole Dimensions

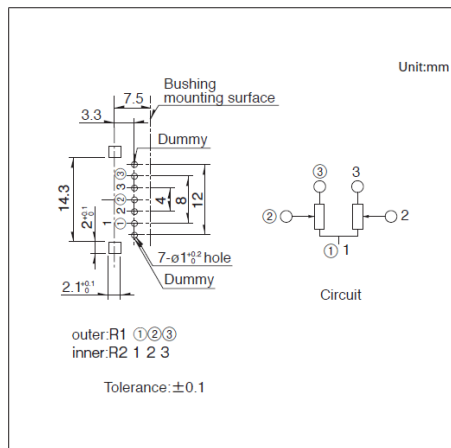

■ Terminal Layout / Circuit Diagram

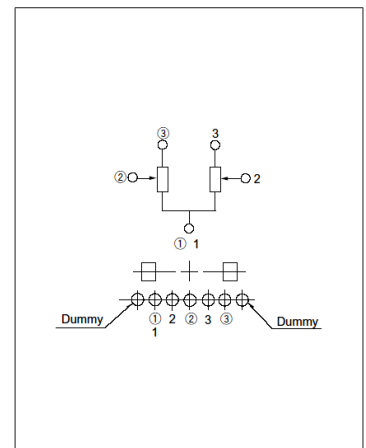

Viewed from mounting side.

Rotary Potentiometer (Insulated shaft type) / Soldering Conditions

■ Reference for Manual Soldering

Series	Tip temperature	Soldering time	No. of solders
RK09D, RK09K, RK09Y11L, RK11K, RK12L, RK14K	350°C max.	3s max.	1 time

■ Reference for Dip Soldering

Series	Preheating		Dip soldering		No. of solders
	Soldering surface temperature	Heating time	Soldering temperature	Soldering time	
RK12L	100°C	1 min. max.	260°C max.	5s max.	2 time max.

Rotary Potentiometer (Knob operating type)

List of Varieties

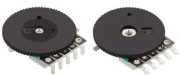
Series		RK10J
Photo		
Dimensions		10mm Size
Number of resistor elements		Dual-unit Single-unit
Soldering		Manual Reflow
Mounting board types		Insertion (t: 2mm) Surface mounting
Operating temperature range		-10°C to +60°C
Operating life (cycles)		10,000
Electrical performance	Total resistance	10kΩ
	Resistance taper	1B 15A
	Total resistance tolerance	±30%
	Rated power	0.03W
	Maximum operating voltage	50V AC 50V AC, 20V DC
	For DC use	20V DC Not applicable
	Insulation resistance	100MΩ min. 100V DC
	Voltage proof	100V AC for 1 minute
Mechanical performance	Total rotational angle	270° ±10°
	Rotational torque	0.5 to 10mN·m
	Stopper strength	70mN·m
	Push-pull strength	5N
Automotive		—

Potentiometers Rotary Potentiometer (Knob operating type)

With Knob Type RK10J Series

Thin-profile design compatible with reflow and dip mounting methods.

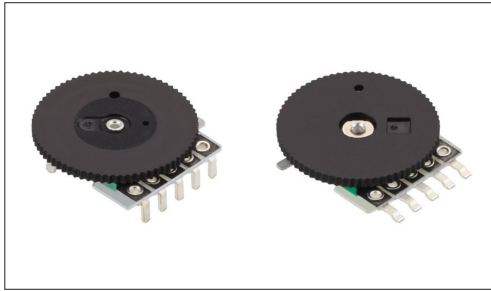

- Total resistance tolerance: $\pm 30\%$
- Maximum operating voltage: 50V AC, 20V DC
- Rotational torque: 0.5 to 10mN·m
- Operating life: 10,000 cycles
- Operating temperature range: -10°C to $+60^{\circ}\text{C}$

Applications: Home: Major home appliances, Office equipment
Audio_TV: Visual, Audio

Product List

Products No.	Number of resistor elements	Soldering	Knob types	Mounting board types	For DC use	Total resistance	Resistance taper	Automotive	Drawing No.
RK10J11E0034	Single-unit	Manual	Outer size: $\phi 14$ Knob thickness: t0.9mm Color: Black	Insertion (t: 2mm)	20V DC	10k Ω	1B	—	1
RK10J12E0A0A	Dual-unit	Manual	Outer size: $\phi 14$ Knob thickness: t0.9mm Color: Black	Insertion (t: 2mm)	Not applicable	10k Ω	15A	—	2
RK10J11R0A0L	Single-unit	Reflow	Outer size: $\phi 14$ Knob thickness: t1.0mm Color: Black	Surface mounting	20V DC	10k Ω	1B	—	3
RK10J12R0A0B	Dual-unit	Reflow	Outer size: $\phi 14$ Knob thickness: t1.0mm Color: Black	Surface mounting	Not applicable	10k Ω	15A	—	4

Note

1. This catalog shows only outline specifications. When using the products, please obtain formal specifications for supply.
2. Please place purchase orders per minimum order unit (integer).
3. Products other than those listed in above products are also available. Please contact us for details.

Packing Specifications

Bulk

Products No.	Number of packages(pcs.)		Export package measurements (mm)
	1 case / Japan	1 case / export packing	
RK10J11E0034 RK10J12E0A0A	3,000	2,400	371 x 250 x 190

Taping

Products No.	Number of packages(pcs.)			Tape width (mm)	Export package measurements (mm)
	1 reel	1 case / Japan	1 case / export packing		
RK10J11R0A0L RK10J12R0A0B	1,000	3,000	3,000	24	401 x 397 x 139

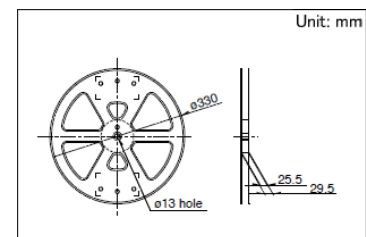

With Knob Type
RK10J Series

Drawing No.1

■ Dimensions

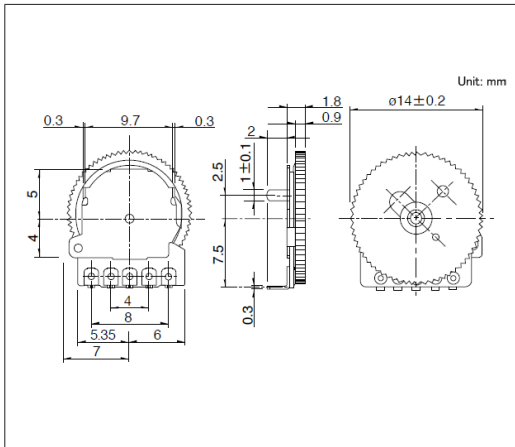

■ Mounting Hole Dimensions

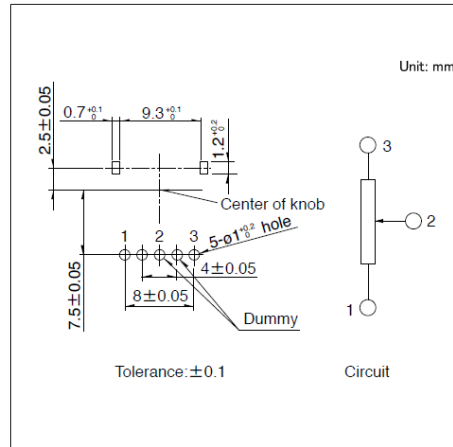

■ Circuit Diagram

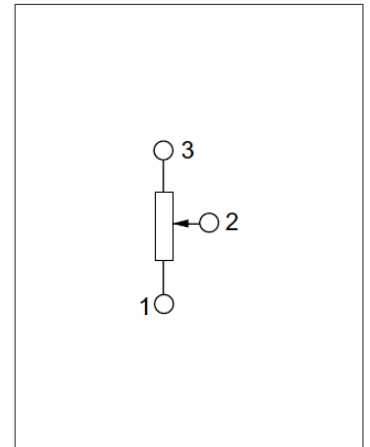

Viewed from mounting side.

Drawing No.2

■ Dimensions

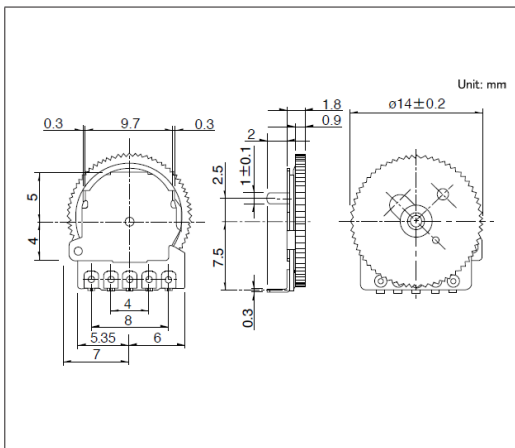

■ Mounting Hole Dimensions

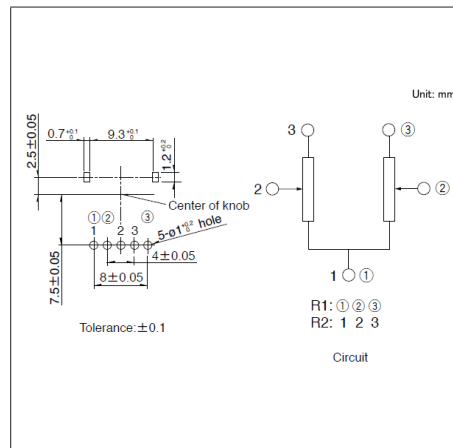

■ Circuit Diagram

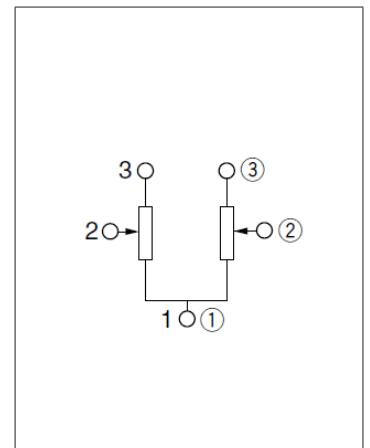

Viewed from mounting side.

Drawing No.3

■ Dimensions

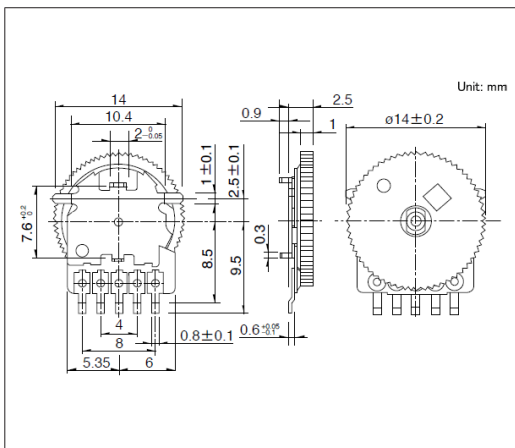

■ Mounting Hole Dimensions

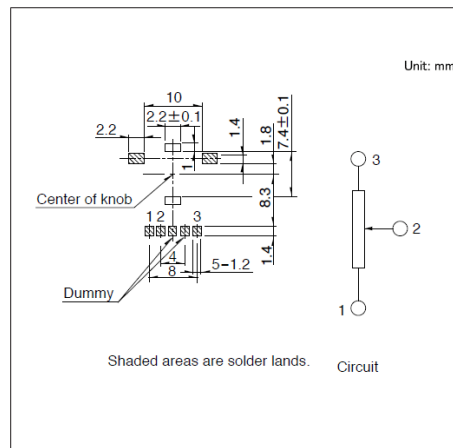

■ Circuit Diagram

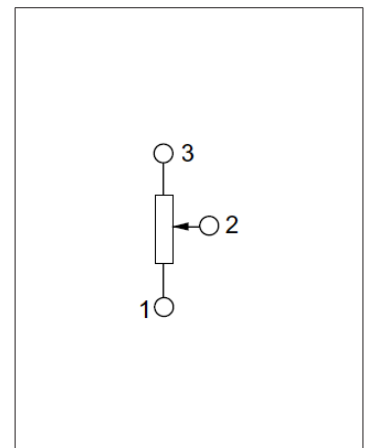

Viewed from mounting side.

With Knob Type
RK10J Series

Drawing No.4

■ Dimensions

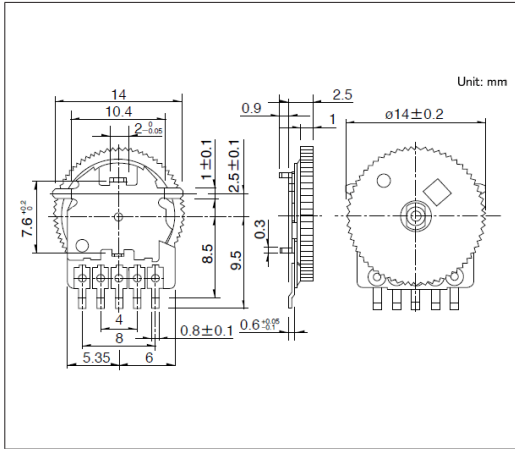

■ Mounting Hole Dimensions

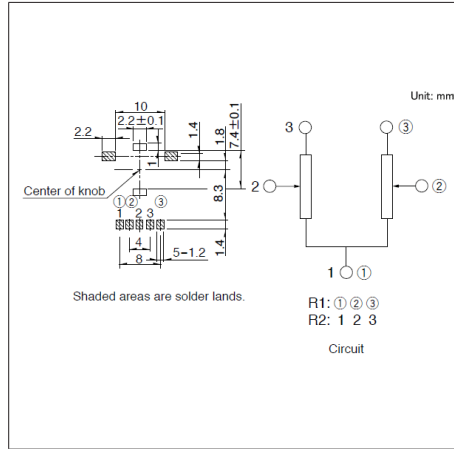

■ Circuit Diagram

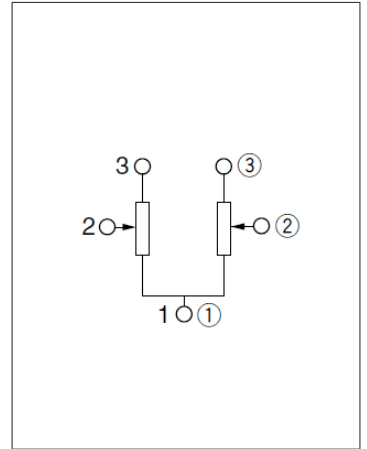

Viewed from mounting side.

Rotary Potentiometer (Knob operating type) / Soldering Conditions

■ Reference for Manual Soldering

Series	Tip temperature	Soldering time	No. of solders
RK10J	350°C max.	3s max.	1 time

■ Example of Reflow Soldering Condition

Temperature profile

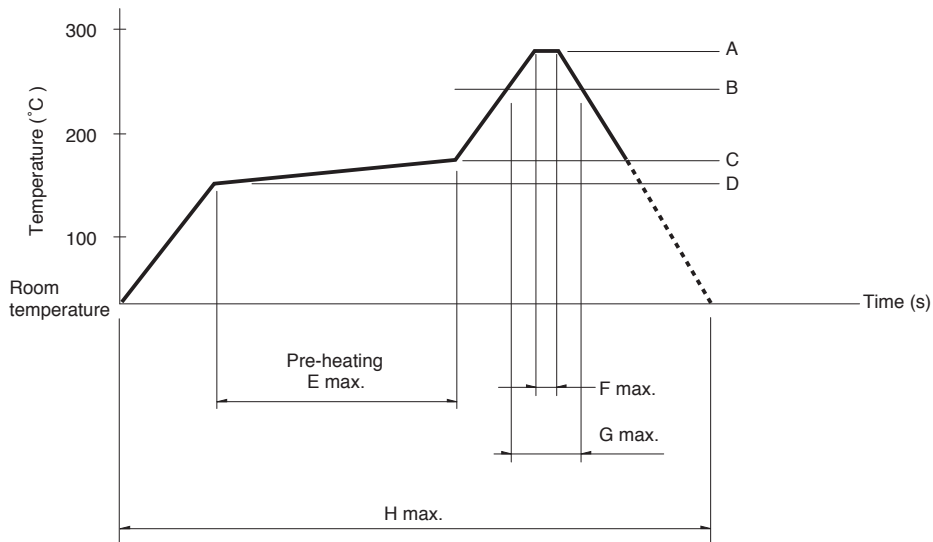



Series	A	B	C	D	E	F	G	H	No. of reflows
RK10J1□R	250°C	200°C	150°C	150°C	2 min.	3s	40s	4 min.	2 time max.

⚠️ Note

1. When using an infrared reflow oven, solder may sometimes not be applied. Be sure to use a hot air reflow oven or a type that uses infrared rays in combination with hot air.
2. The temperatures given above are the maximum temperatures at the terminals of the potentiometer when employing a hot air reflow method. The temperature of the PC board and the surface temperature of the potentiometer may vary greatly depending on the PC board material, its size and thickness. Ensure that the surface temperature of the potentiometer does not rise to 250°C or greater.
3. Conditions vary to some extent depending on the type of reflow bath used. Be sure to give due consideration to this prior to use.

Rotary Potentiometer (Ring type)

List of Varieties

Series		RK39A	RK45C
Photo			
Dimensions		39mm size	45mm size
Number of resistor elements		Single-unit	
Number of positions		6/17	17
Total rotational angle		180° ±5° 220° ±5° 270° ±5° (290° max.)	220° ±5° (290° max.)
Detent torque		40±16mN·m 50±20mN·m	40±16mN·m
Operating temperature range		-40°C to +85°C	
Operating life (cycles)		30,000	
Electrical performance	Total resistance	5kΩ	
	Resistance taper	B	
	Total resistance tolerance	±20%	
	Rated power	0.05W	
	Maximum operating voltage	50V AC, 30V DC	
	Insulation resistance	10MΩ min. 50V DC	
	Voltage proof	50V AC for 1 minute	
Mechanical performance	Stopper strength	1N·m	
	Push-pull strength	100N (Push), 50N (Pull)	
	Vibration	10 to 55 to 10Hz/min., the amplitude is 1.5mm for all the frequencies, in the 3 direction of X, Y and Z for 2 hours respectively	
Automotive		●	●

Note

● Indicates applicability to all products in the series, while ○ indicates applicability to some products in the series.

Potentiometers Rotary Potentiometer (Ring type)

39mm Size LED Illuminated Type RK39A Series

LED-illuminated volume optimized for knob designs in various set devices.

Automotive



- Total resistance tolerance: $\pm 20\%$
- Maximum operating voltage: 50V AC, 30V DC
- Operating life: 30,000 cycles
- Operating temperature range: -40°C to $+85^{\circ}\text{C}$

Applications: Automotive: Navigation/audio systems, HVAC

■ Product List

Products No.	Total rotational angle	Detent	Detent torque	Total resistance	Resistance taper	Automotive	Drawing No.
RK39A1A00007	$220^{\circ}\pm 5^{\circ}$ (290° max.)	17-position	$40\pm 16\text{mN}\cdot\text{m}$	5k Ω	B	●	1
RK39A1A00027	$180^{\circ}\pm 5^{\circ}$ (290° max.)	17-position	$50\pm 20\text{mN}\cdot\text{m}$	5k Ω	B	●	2
RK39A1A00028	$270^{\circ}\pm 5^{\circ}$ (290° max.)	6-position	$50\pm 20\text{mN}\cdot\text{m}$	5k Ω	B	●	1

Note

1. This catalog shows only outline specifications. When using the products, please obtain formal specifications for supply.
2. Please place purchase orders per minimum order unit (integer).
3. Products other than those listed in above products are also available. Please contact us for details.
4. We can also provide LED colors other than the above mentioned. Contact us if you have such requirements.

■ Packing Specifications

Tray

Number of packages (pcs.)		Export package measurements (mm)
1 case / Japan	1 case / export packing	
250	500	540 x 360 x 380

Drawing No.1

■ Dimensions

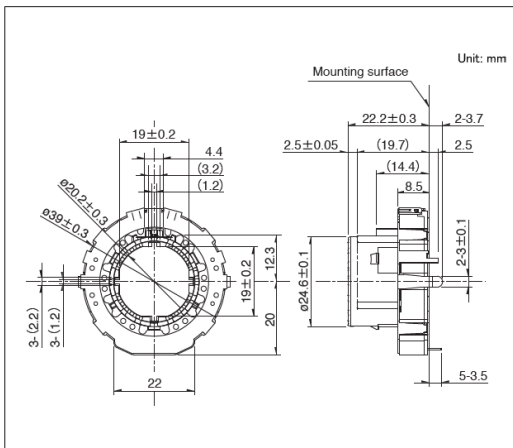

■ Mounting Hole Dimensions

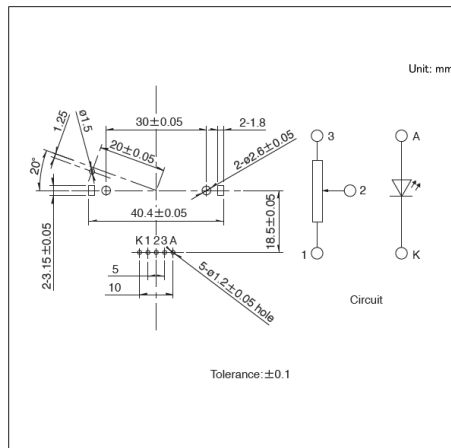

Potentiometers Rotary Potentiometer (Ring type)

45mm Size LED Illuminated Type
RK45C Series

LED-illuminated volume optimized for knob designs in various set devices.

 Automotive



- Total resistance tolerance: ±20%
- Maximum operating voltage: 50V AC, 30V DC
- Operating life: 30,000 cycles
- Operating temperature range: -40°C to +85°C

Applications: Automotive: Navigation/audio systems, HVAC

■ Product List

Products No.	Total rotational angle	Detent	Detent torque	Total resistance	Resistance taper	Automotive	Drawing No.
RK45C1A00003	220°±5° (290°max.)	17-position	40±16mN·m	5kΩ	B	●	1

 Note

1. This catalog shows only outline specifications. When using the products, please obtain formal specifications for supply.
2. Please place purchase orders per minimum order unit (integer).
3. Products other than those listed in above products are also available. Please contact us for details.
4. We can also provide LED colors other than the above mentioned. Contact us if you have such requirements.

■ Packing Specifications

Tray

Number of packages (pcs.)		Export package measurements (mm)
1 case / Japan	1 case / export packing	
200	400	540 x 360 x 380

Drawing No. 1

■ Dimensions

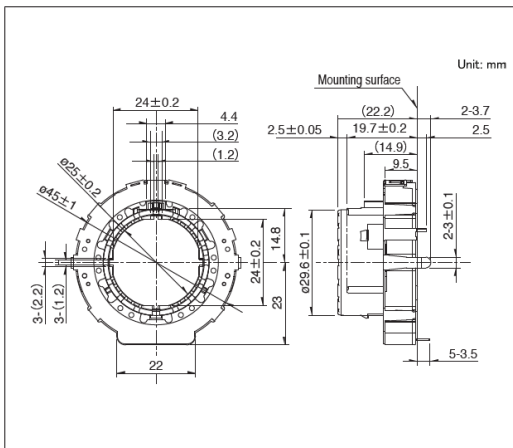

■ Mounting Hole Dimensions

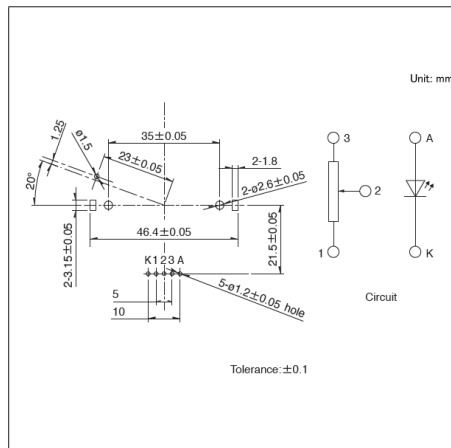

Viewed from mounting face.

Rotary Potentiometer (Ring type) / Soldering Conditions

■ Reference for Manual Soldering

Series	Tip temperature	Soldering time	No. of solders
RK39A, RK45C	350°C max.	3s max.	1 time



■ Reference for Dip Soldering

Series	Preheating		Dip soldering		No. of solders
	Soldering surface temperature	Heating time	Soldering temperature	Soldering time	
RK39A, RK45C	100°C max.	2 min. max.	260°C max.	5s max.	2 times max.

Potentiometers

Slide Potentiometer (Standard type)

List of Varieties

Series		RS**1	RS**H
Photo			
Direction of lever	Horizontal	—	●
	Vertical	●	●
Number of resistor elements		Dual-unit Single-unit	
Travel (mm)		15 20 30 45 60	15 20 30
Lever type		4 6 9-1 A B J-1	A C
Length of lever (mm)		5.0 10.0 15.0 20.0	4.5 9.5 14.5
Operating temperature range		-25°C to +70°C	
Operating life (cycles)		15,000	10,000
Electrical performance	Total resistance	10kΩ	10kΩ 50kΩ 100kΩ 250kΩ
	Resistance taper	1B	1B 3B 15A
	Total resistance tolerance	±20%	
	Rated power	0.05W 0.1W 0.125W 0.2W 0.25W	0.012W 0.025W 0.05W 0.1W
	Maximum operating voltage	100V AC, 10V DC 200V AC, 10V DC	50V AC, 10V DC 100V AC, 10V DC 150V AC, 10V DC 200V AC, 10V DC
	Insulation resistance	100MΩ min. 250V DC	
	Voltage proof	300V AC for 1 minute	
Mechanical performance	Operating force	0.3 to 2.5N	0.6(+0.5, -0.4)N
	Stopper strength	50N	30N
	Lever push-pull strength	50N	30N
	Lever wobble (Both side)	1mm 2mm 3mm 4mm	1.6mm max.
	Lever deviation (One side)	0.5mm max.	—
Automotive		●	—



● Indicates applicability to all products in the series, while ○ indicates applicability to some products in the series.

Potentiometers Slide Potentiometer (Standard type)

Super Slide (Standard Type)

RS**1 Series

Wide product variety with auto-dip compatibility.

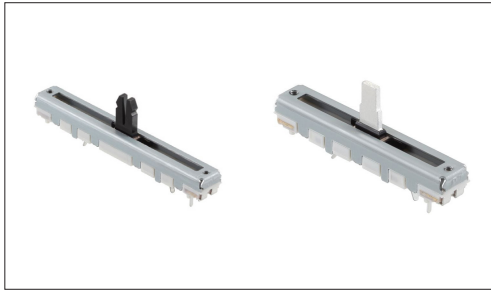

 Automotive

- Total resistance tolerance: $\pm 20\%$
- Operating life: 15,000 cycles
- Operating temperature range: -25°C to $+70^{\circ}\text{C}$

Applications: Home: Major home appliances, Office equipment
 Audio_TV: Visual, Audio
 Automotive: Navigation/audio systems, HVAC

■ Product List

Products No.	Type	Number of resistor elements	Direction of lever	Travel (mm)	Lever type	Length of lever (mm)	Total resistance	Resistance taper	Detent	Mounting plate	Maximum operating voltage	Automotive	Drawing No.
RS151111J026	Insulated lever	Single-unit	Vertical	15	J-1	5.0	10k Ω	1B	Without	Without	100V AC, 10V DC	●	1
RS201111J011		Single-unit	Vertical	20	J-1	5.0	10k Ω	1B	Without	Without	200V AC, 10V DC	●	2
RS301111A01G		Single-unit	Vertical	30	A	10.0	10k Ω	1B	Without	Without	200V AC, 10V DC	●	3
RS451111B010		Single-unit	Vertical	45	B	10.0	10k Ω	1B	Without	Without	200V AC, 10V DC	●	4
RS151111A9A03	Metal lever	Single-unit	Vertical	15	9-1	10.0	10k Ω	1B	Without	With	100V AC, 10V DC	●	5
RS201111A9A03		Single-unit	Vertical	20	9-1	10.0	10k Ω	1B	Without	With	200V AC, 10V DC	●	6
RS301111A9012		Single-unit	Vertical	30	9-1	10.0	10k Ω	1B	Without	With	200V AC, 10V DC	●	7
RS451111A900F		Single-unit	Vertical	45	9-1	10.0	10k Ω	1B	Without	With	200V AC, 10V DC	●	8
RS601111YA9A07		Single-unit	Vertical	60	9-1	10.0	10k Ω	1B	Without	With	200V AC, 10V DC	●	9
RS301112A900S		Dual-unit	Vertical	30	9-1	10.0	10k Ω	1B	Without	With	200V AC, 10V DC	●	10
RS451112A400G		Dual-unit	Vertical	45	4	20.0	10k Ω	1B	Without	With	200V AC, 10V DC	●	11
RS601112A6A0C		Dual-unit	Vertical	60	6	15.0	10k Ω	1B	Without	With	200V AC, 10V DC	●	12

Note

1. This catalog shows only outline specifications. When using the products, please obtain formal specifications for supply.
2. Please place purchase orders per minimum order unit (integer).
3. Products other than those listed in above products are also available. Please contact us for details.
4. Please read "Lever Types" for the kinds and code of lever type.
5. This products can be used in vehicles. Please contact us for details.

Potentiometers Slide Potentiometer (Standard type)

Super Slide (Standard Type)
RS1 Series**
■ Lever Types

Unit:mm

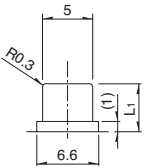
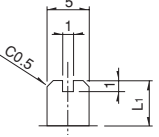
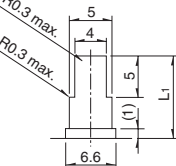
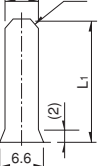
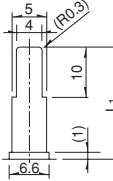
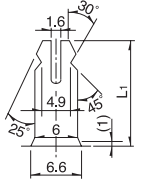
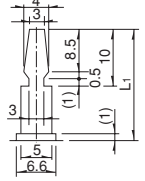
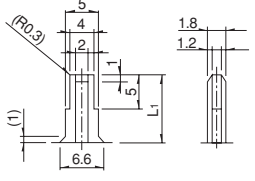
Metal lever		Insulated lever							
Code	Dimensions	Code	Dimensions						
9-2	 <table border="1" style="margin-left: 200px;"> <tr><td>L₁</td></tr> <tr><td>5</td></tr> </table>	L ₁	5	J-1	 <table border="1" style="margin-left: 200px;"> <tr><td>L₁</td></tr> <tr><td>5</td></tr> </table>	L ₁	5		
L ₁									
5									
L ₁									
5									
9-1	 <table border="1" style="margin-left: 200px;"> <tr><td>L₁</td></tr> <tr><td>10</td></tr> </table>	L ₁	10	A	 <table border="1" style="margin-left: 200px;"> <tr><td>L₁</td></tr> <tr><td>10</td></tr> <tr><td>15</td></tr> </table>	L ₁	10	15	
L ₁									
10									
L ₁									
10									
15									
6	 <table border="1" style="margin-left: 200px;"> <tr><td>L₁</td></tr> <tr><td>15</td></tr> <tr><td>20</td></tr> </table>	L ₁	15	20	B	 <table border="1" style="margin-left: 200px;"> <tr><td>L₁</td></tr> <tr><td>10</td></tr> <tr><td>15</td></tr> </table>	L ₁	10	15
L ₁									
15									
20									
L ₁									
10									
15									
4	 <table border="1" style="margin-left: 200px;"> <tr><td>L₁</td></tr> <tr><td>15</td></tr> <tr><td>20</td></tr> </table>	L ₁	15	20	C	 <table border="1" style="margin-left: 200px;"> <tr><td>L₁</td></tr> <tr><td>10</td></tr> <tr><td>15</td></tr> </table>	L ₁	10	15
L ₁									
15									
20									
L ₁									
10									
15									

■ Packing Specifications
Tray

Products No.	Number of packages (pcs.)		Export package measurements (mm)
	1 case / Japan	1 case / export packing	
RS151111J026 RS201111J011 RS151111A9A03 RS201111A9A03	700	2,800	518 x 378 x 422
RS301111A01G RS301111A9012 RS30112A900S	600	2,400	518 x 378 x 422
RS451111B010 RS451111A900F	1,300	1,300	529 x 373 x 273
RS60111YA9A07 RS60112A6A0C	900	900	529 x 373 x 273
RS45112A400G	1,150	1,150	529 x 373 x 273

Super Slide (Standard Type)
RS**1 Series

Drawing No.1

■ Dimensions

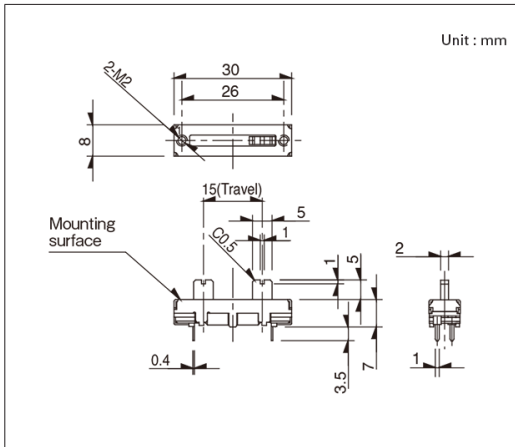

■ Mounting Hole Dimensions

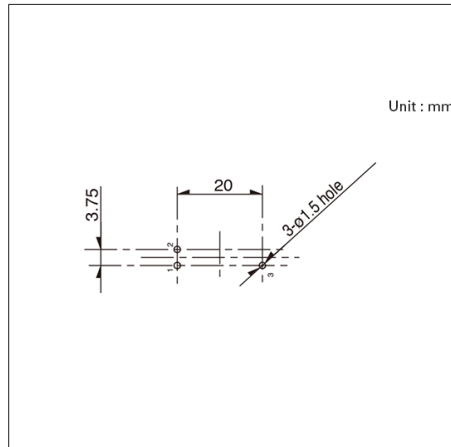

■ Terminal Layout / Circuit Diagram

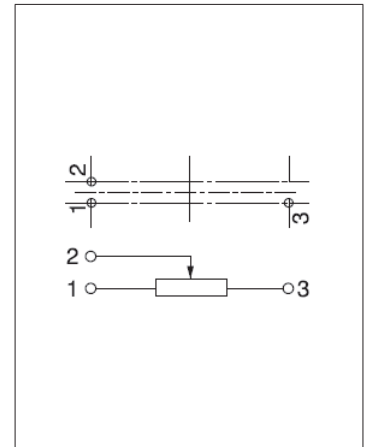

Viewed from mounting side.

Drawing No.2

■ Dimensions

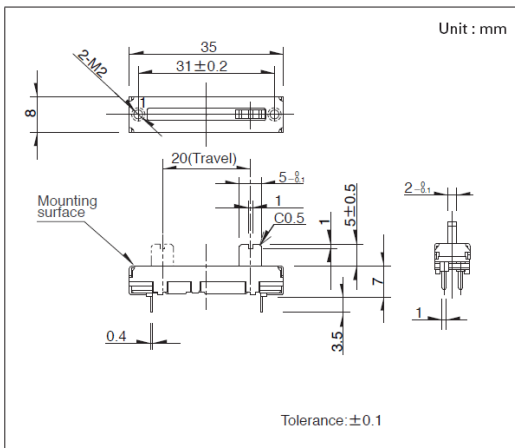

■ Mounting Hole Dimensions

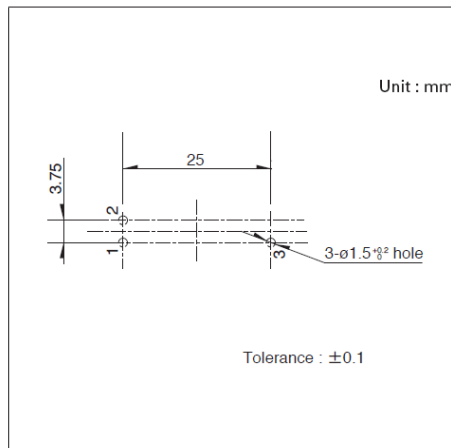

■ Terminal Layout / Circuit Diagram

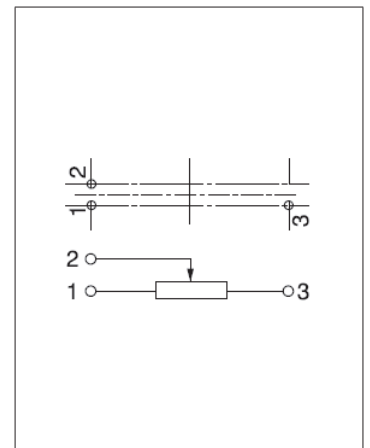

Viewed from mounting side.

Drawing No.3

■ Dimensions

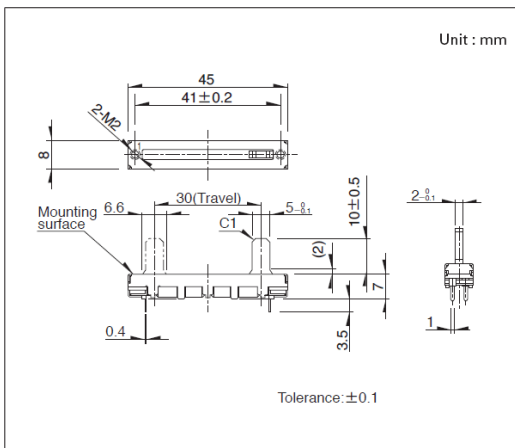

■ Mounting Hole Dimensions

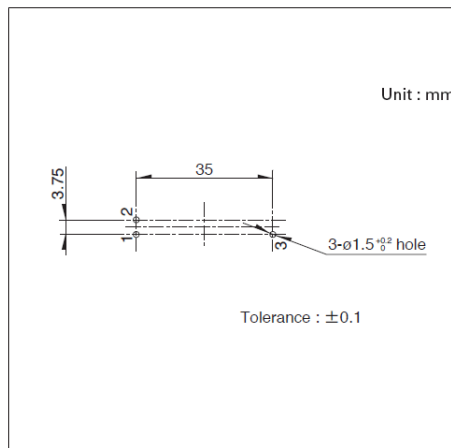

■ Terminal Layout / Circuit Diagram

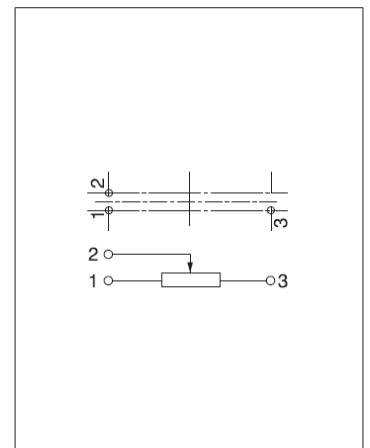

Viewed from mounting side.

Super Slide (Standard Type)
RS**1 Series

Drawing No.4

■ Dimensions

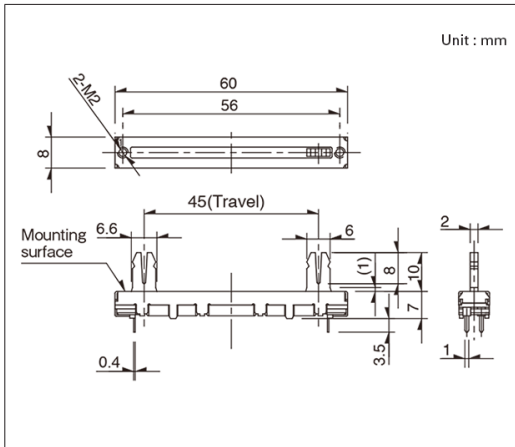

■ Mounting Hole Dimensions

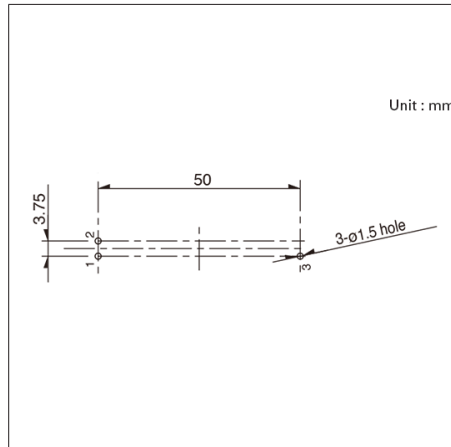

■ Terminal Layout / Circuit Diagram

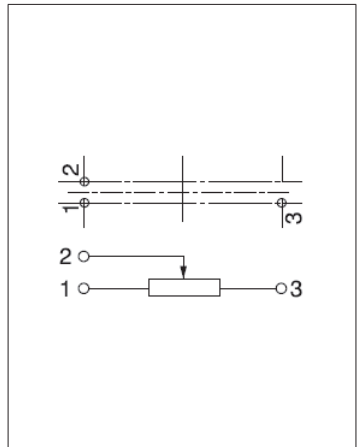

Viewed from mounting side.

Drawing No.5

■ Dimensions

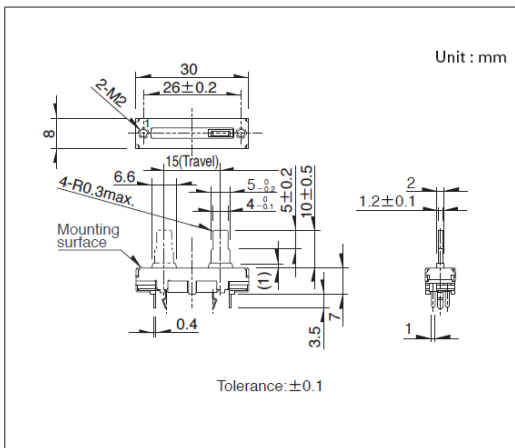

■ Mounting Hole Dimensions

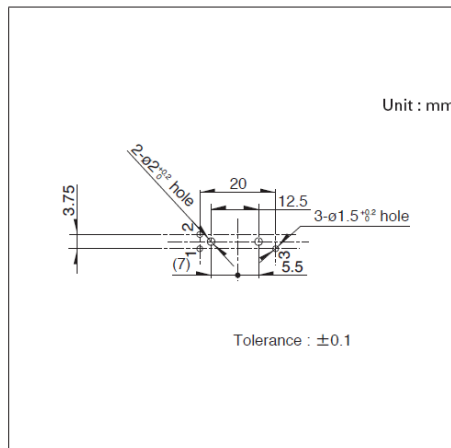

■ Terminal Layout / Circuit Diagram

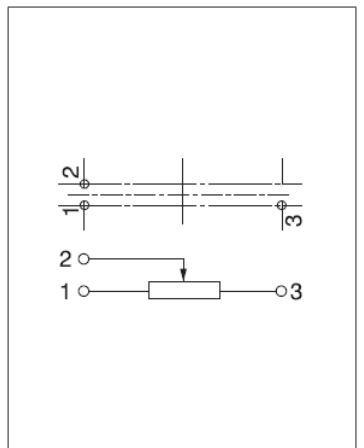

Viewed from mounting side.

Drawing No.6

■ Dimensions

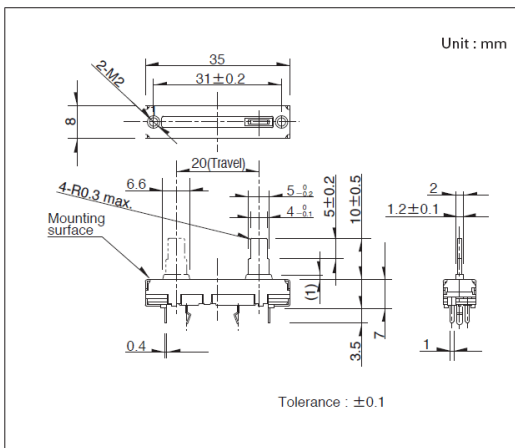

■ Mounting Hole Dimensions

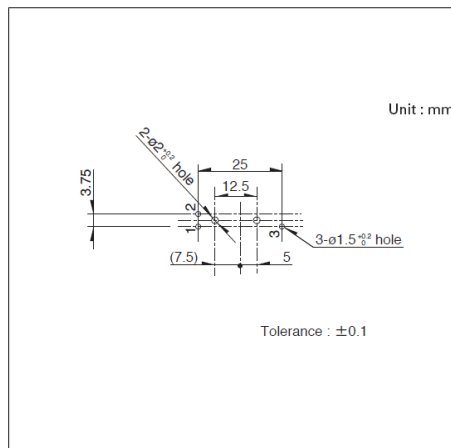

■ Terminal Layout / Circuit Diagram

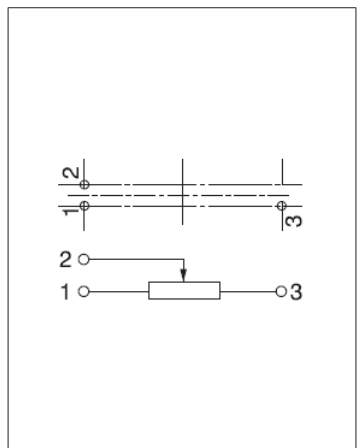

Viewed from mounting side.

Super Slide (Standard Type)
RS**1 Series

Drawing No.7

■ Dimensions

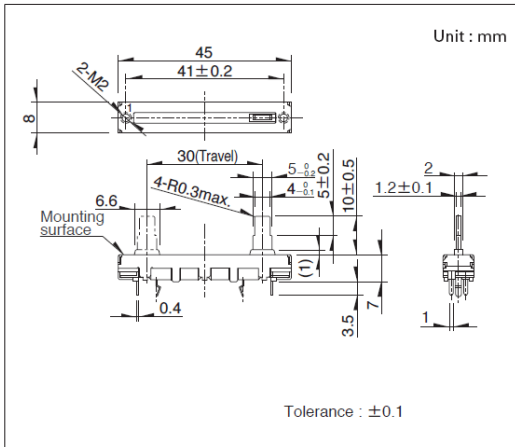

■ Mounting Hole Dimensions

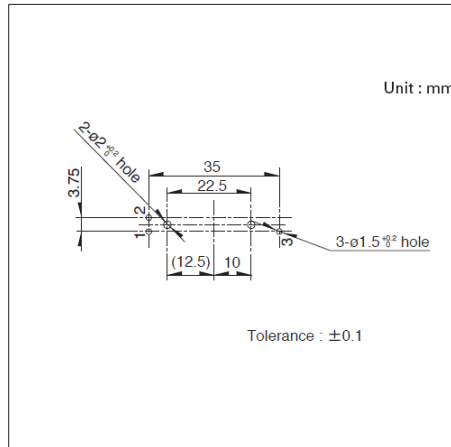

■ Terminal Layout / Circuit Diagram

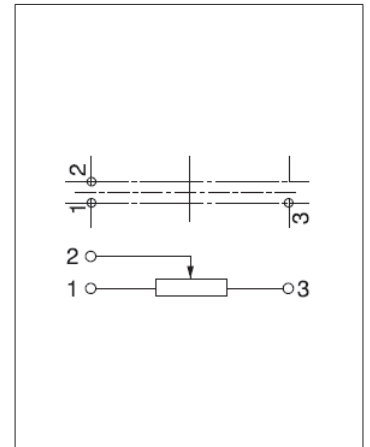

Viewed from mounting side.

Drawing No.8

■ Dimensions

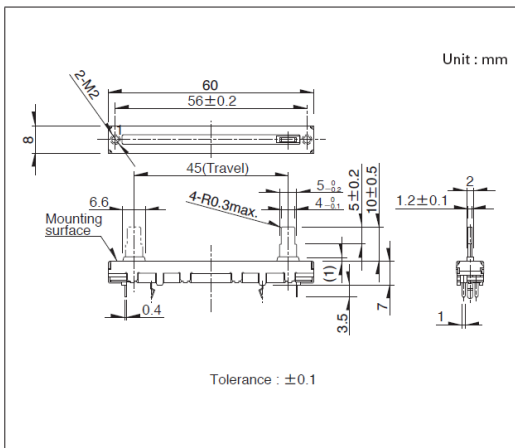

■ Mounting Hole Dimensions

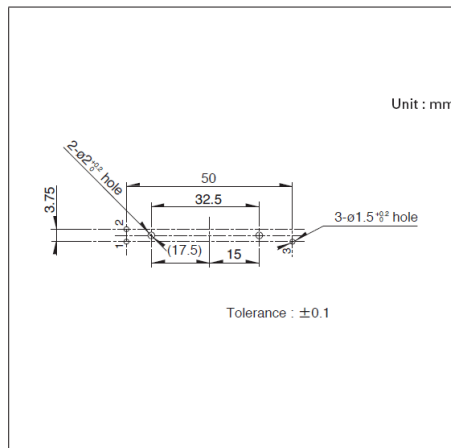

■ Terminal Layout / Circuit Diagram

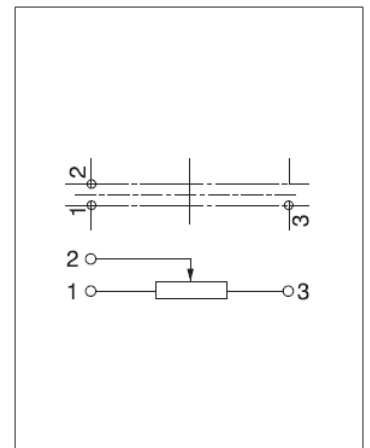

Viewed from mounting side.

Drawing No.9

■ Dimensions

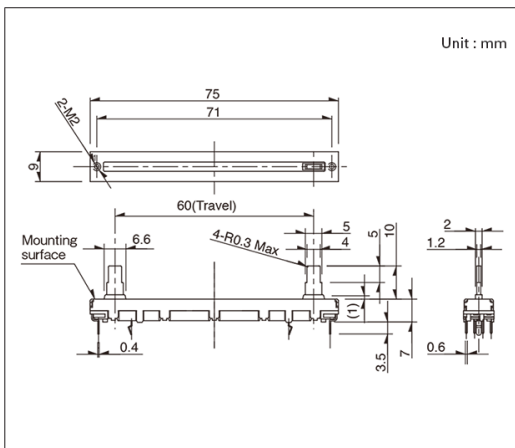

■ Mounting Hole Dimensions

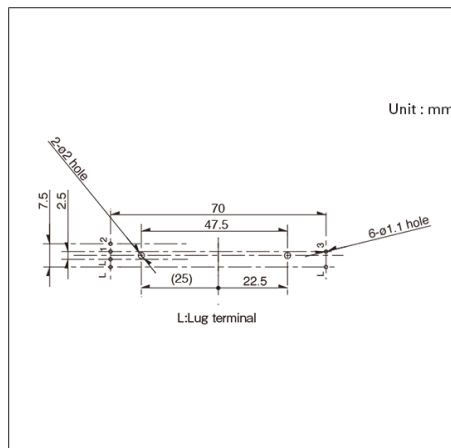

■ Terminal Layout / Circuit Diagram

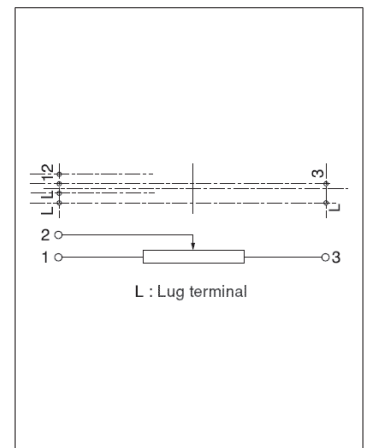

Viewed from mounting side.

Drawing No.10

■ Dimensions

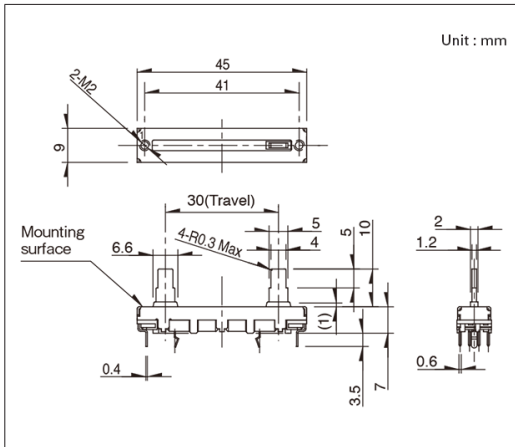

■ Mounting Hole Dimensions

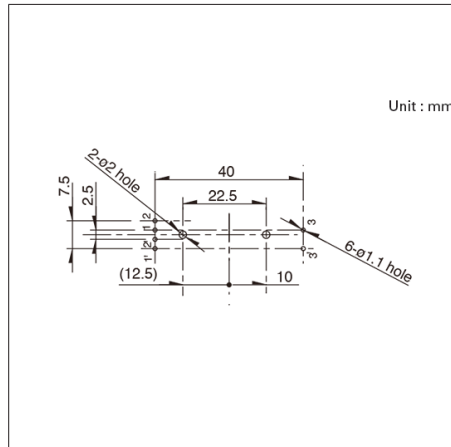

■ Terminal Layout / Circuit Diagram

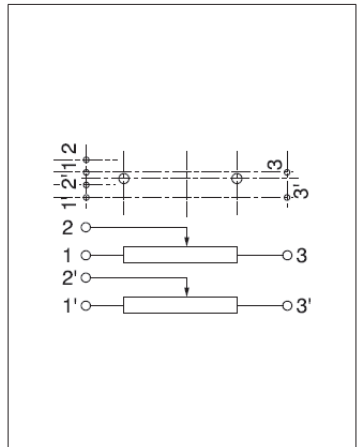

Viewed from mounting side.

Drawing No.11

■ Dimensions

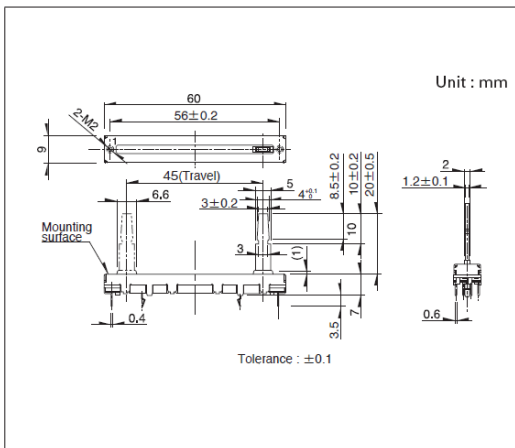

■ Mounting Hole Dimensions

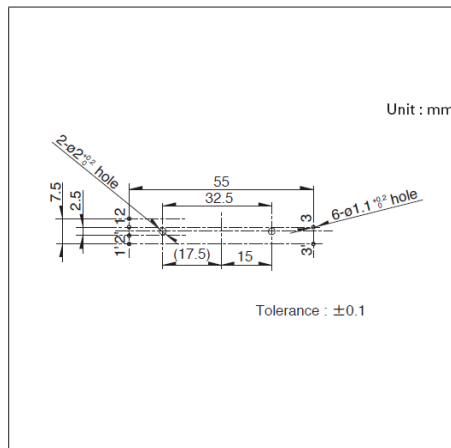

■ Terminal Layout / Circuit Diagram

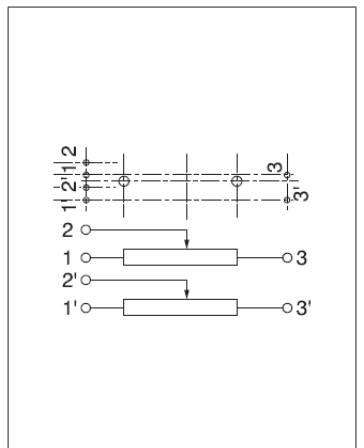

Viewed from mounting side.

Drawing No.12

■ Dimensions

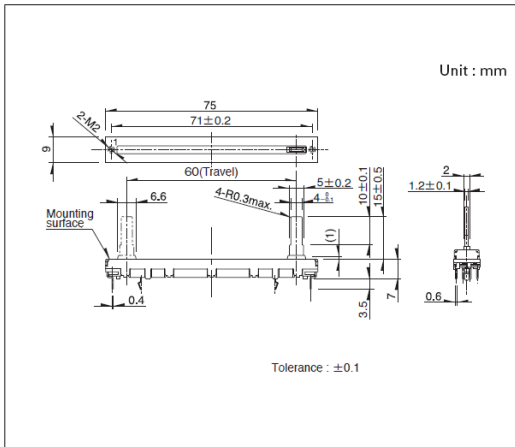

■ Mounting Hole Dimensions

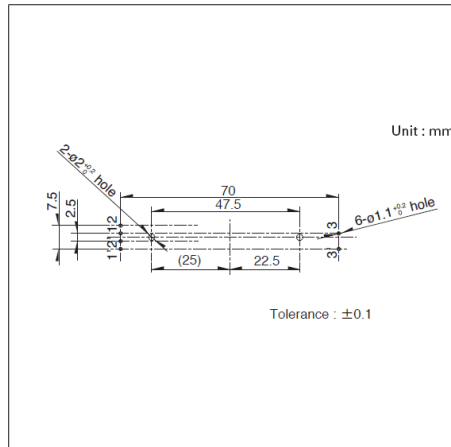

■ Terminal Layout / Circuit Diagram

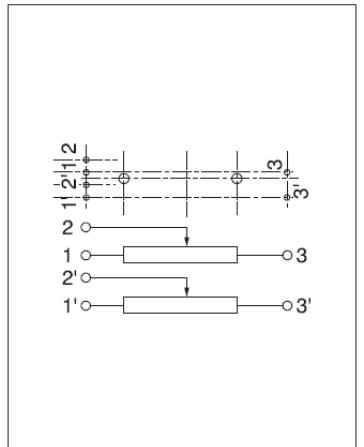

Viewed from mounting side.

Potentiometers

Slide Potentiometer (Standard type)

Slim Slide (Slim 4) RS**H Series

Achieves miniaturization with a total length of travel of +15mm, improving operation feel.

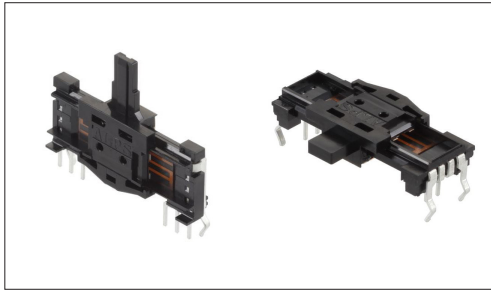

- Total resistance tolerance: $\pm 20\%$
- Operating life: 10,000 cycles
- Operating temperature range: -25°C to $+70^{\circ}\text{C}$

Applications: Home: Major home appliances, Office equipment
Audio_TV: Visual, Audio

Product List

Products No.	Number of resistor elements	Direction of lever	Travel (mm)	Lever type	Length of lever (mm)	Total resistance	Resistance taper	Detent	Maximum operating voltage	Automotive	Drawing No.
RS15H111CA04	Single-unit	Vertical	15	C	9.5	50k Ω	1B	Without	100V AC, 10V DC	—	1
RS20H111C009	Single-unit	Vertical	20	C	14.5	50k Ω	1B	Without	100V AC, 10V DC	—	2
RS30H111A00D	Single-unit	Vertical	30	A	4.5	10k Ω	15A	Without	150V AC, 10V DC	—	3
RS15H11AA008	Single-unit	Horizontal	15	A	4.5	10k Ω	1B	Without	100V AC, 10V DC	—	4
RS20H11AA015	Single-unit	Horizontal	20	A	4.5	10k Ω	1B	Without	100V AC, 10V DC	—	5
RS30H11AA009	Single-unit	Horizontal	30	A	4.5	10k Ω	1B	Without	200V AC, 10V DC	—	6
RS15H121A009	Dual-unit	Vertical	15	A	4.5	10k Ω	15A	Without	50V AC, 10V DC	—	7
RS20H123A01C	Dual-unit	Vertical	20	A	9.5	100k Ω	1B	Center detent	100V AC, 10V DC	—	8
RS30H121A00B	Dual-unit	Vertical	30	A	4.5	10k Ω	1B	Without	200V AC, 10V DC	—	9
RS15H12AA00F	Dual-unit	Horizontal	15	A	4.5	10k Ω	1B	Without	100V AC, 10V DC	—	10
RS20H12AC002	Dual-unit	Horizontal	20	C	14.5	250k Ω	3B	Without	100V AC, 10V DC	—	11
RS30H12AA003	Dual-unit	Horizontal	30	A	4.5	50k Ω	15A	Without	150V AC, 10V DC	—	12

⚠ Note

1. This catalog shows only outline specifications. When using the products, please obtain formal specifications for supply.
2. Place your purchase order in N minimum package units (N: integer).
3. Products other than those listed in above products are also available. Please contact us for details.
4. Please read "Lever Types" for the kinds and code of lever type.

Lever Types

Configuration code	A		C		D	
Dimensions						
Length L ₁	4.5	9.5	9.5	14.5	9.5	14.5

Potentiometers Slide Potentiometer (Standard type)

Slim Slide (Slim 4)
RS**H Series

■ Packing Specifications

Tray

Products No.	Number of packages (pcs.)		Export package measurements (mm)
	1 case / Japan	1 case / export packing	
RS15H111CA04 RS15H121A009	2,900	5,800	514 x 378 x 512
RS20H111C009 RS20H123A01C	2,500	5,000	514 x 378 x 512
RS30H111A00D RS30H121A00B	2,000	4,000	514 x 378 x 512
RS15H11AA008 RS20H11AA015 RS15H12AA00F RS20H12AC002	2,750	5,500	508 x 374 x 408
RS30H11AA009 RS30H12AA003	1,980	3,960	508 x 374 x 408

Drawing No.1

■ Dimensions

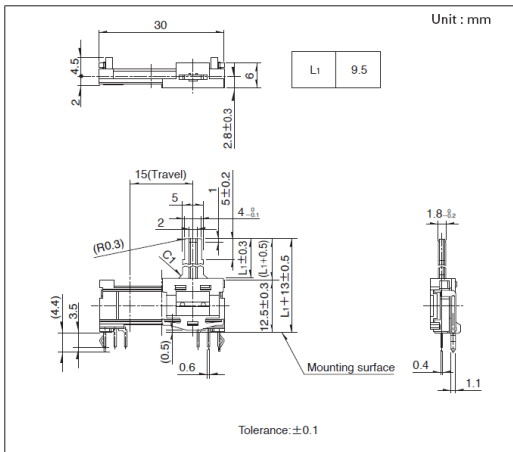

■ Mounting Hole Dimensions

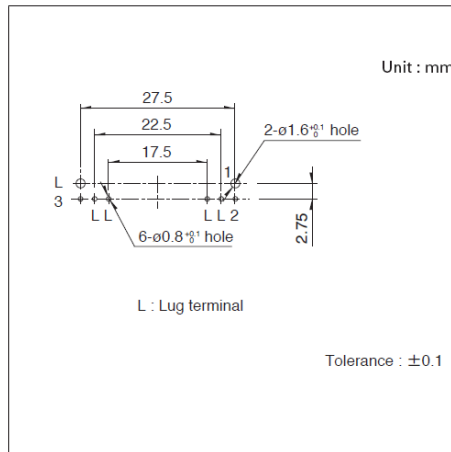

■ Terminal Layout / Circuit Diagram

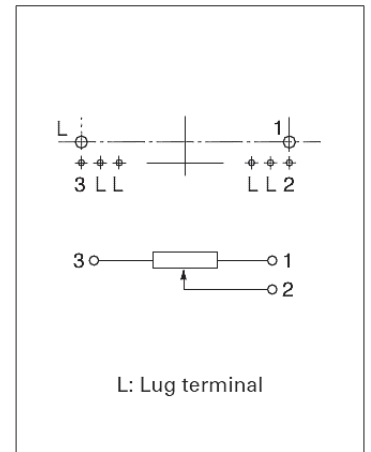

Viewed from mounting side.

Drawing No.2

■ Dimensions

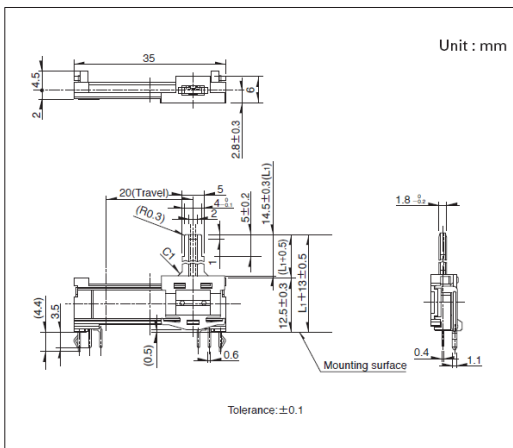

■ Mounting Hole Dimensions

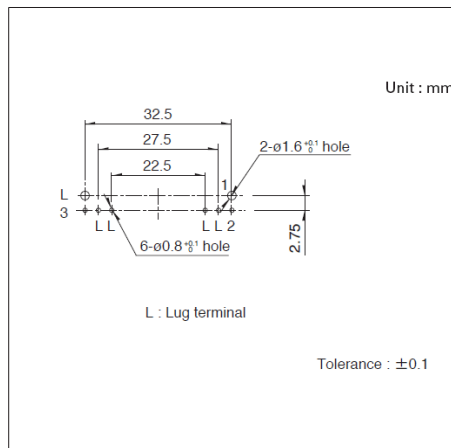

■ Terminal Layout / Circuit Diagram

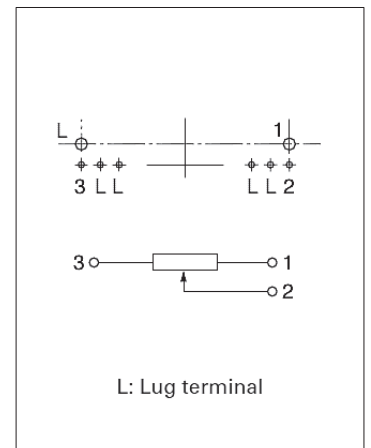

Viewed from mounting side.

Slim Slide (Slim 4)
RS**H Series

Drawing No.3

■ Dimensions

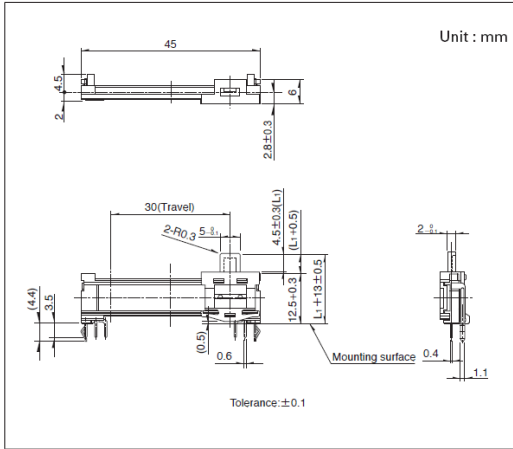

■ Mounting Hole Dimensions

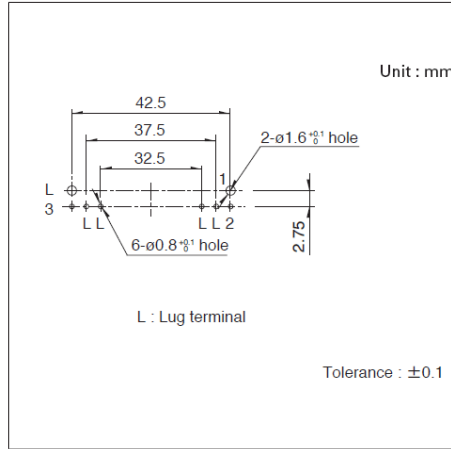

■ Terminal Layout / Circuit Diagram

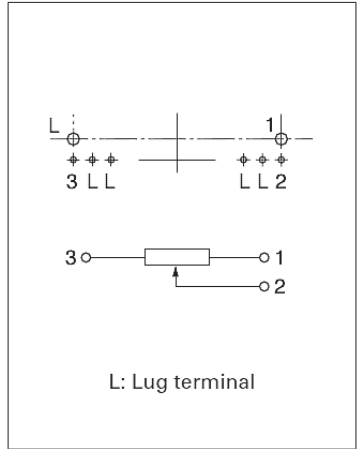

Viewed from mounting side.

Drawing No.4

■ Dimensions

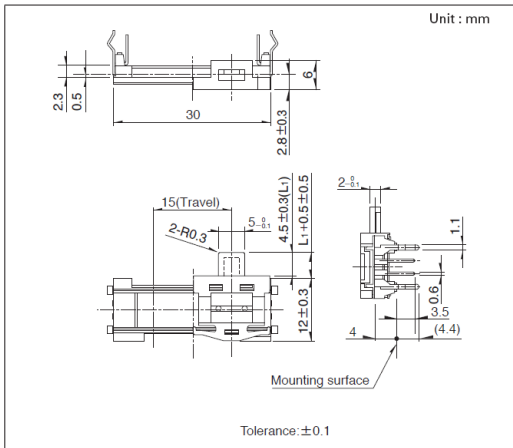

■ Mounting Hole Dimensions

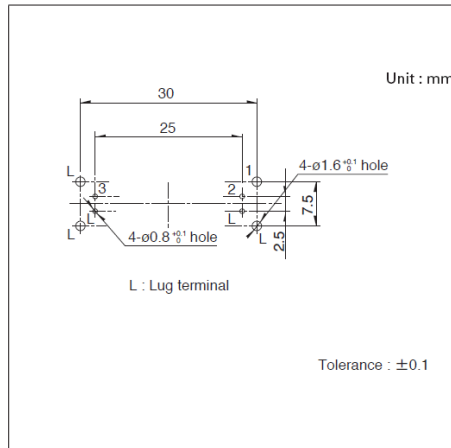

■ Terminal Layout / Circuit Diagram

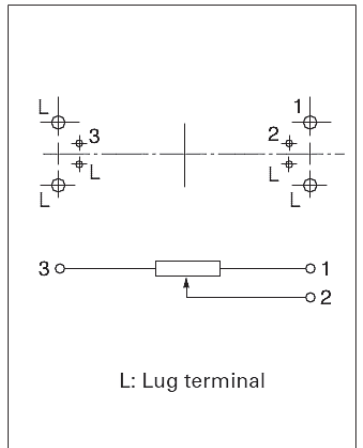

Viewed from mounting side.

Drawing No.5

■ Dimensions

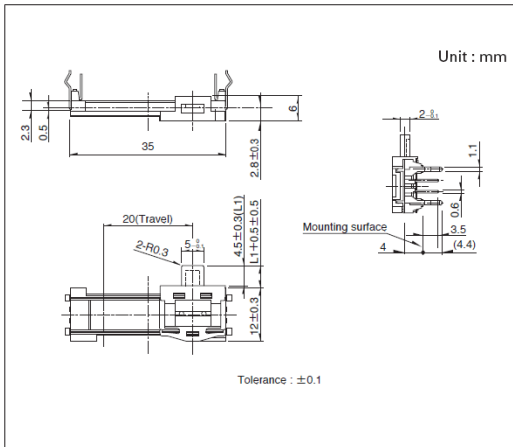

■ Mounting Hole Dimensions

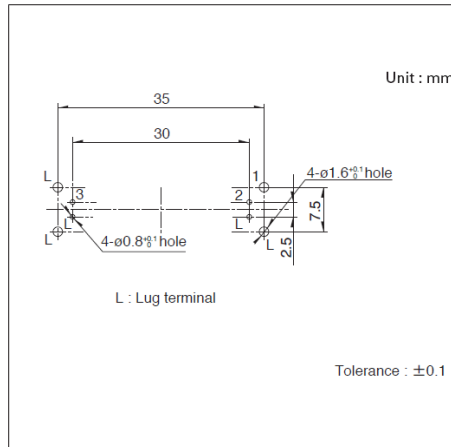

■ Terminal Layout / Circuit Diagram

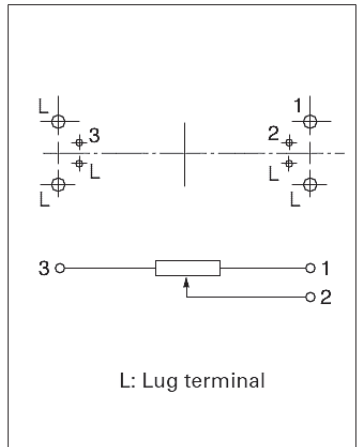

Viewed from mounting side.

Slim Slide (Slim 4)
RS**H Series

Drawing No.6

■ Dimensions

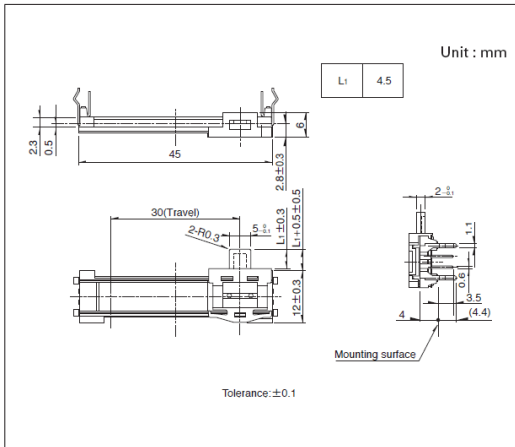

■ Mounting Hole Dimensions

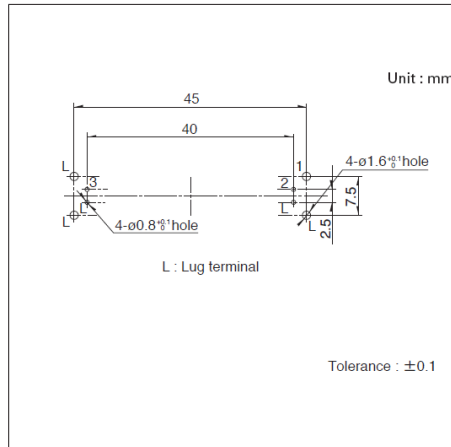

■ Terminal Layout / Circuit Diagram

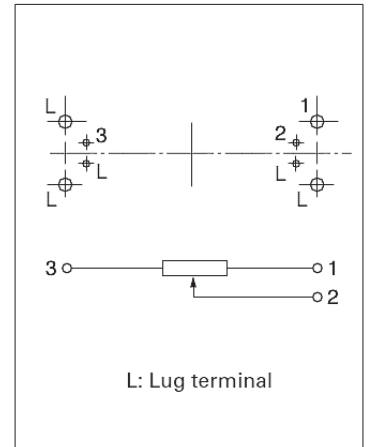

Viewed from mounting side.

Drawing No.7

■ Dimensions

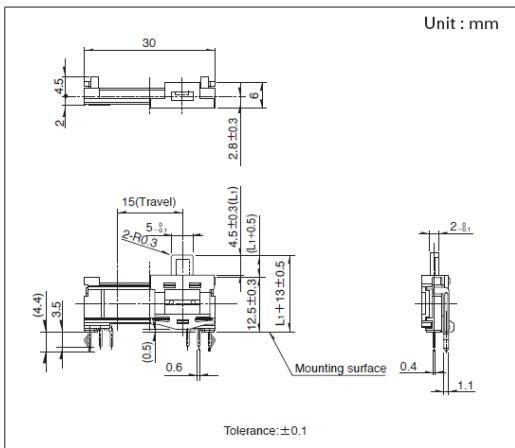

■ Mounting Hole Dimensions

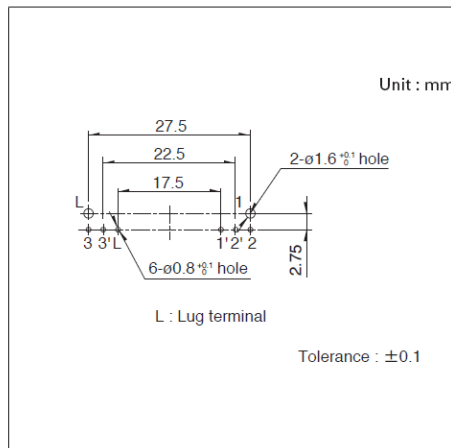

■ Terminal Layout / Circuit Diagram

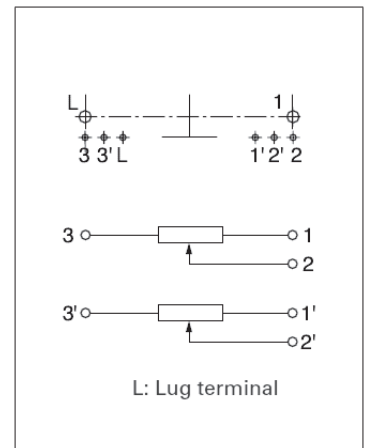

Viewed from mounting side.

Drawing No.8

■ Dimensions

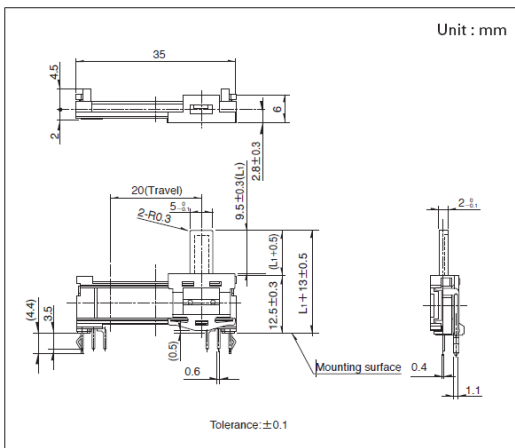

■ Mounting Hole Dimensions

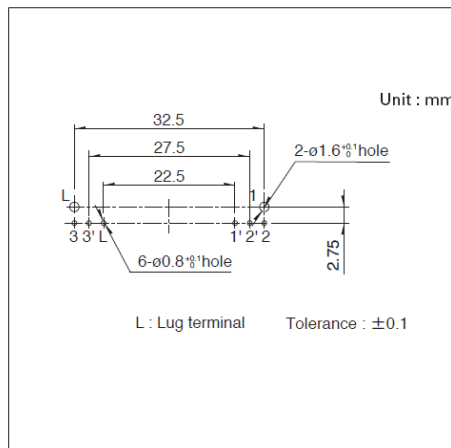

■ Terminal Layout / Circuit Diagram

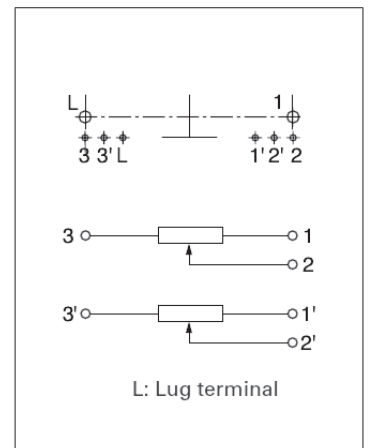

Viewed from mounting side.

Slim Slide (Slim 4)
RS**H Series

Drawing No.9

■ Dimensions

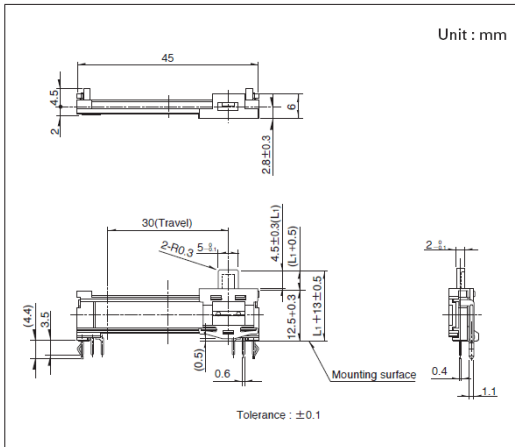

■ Mounting Hole Dimensions

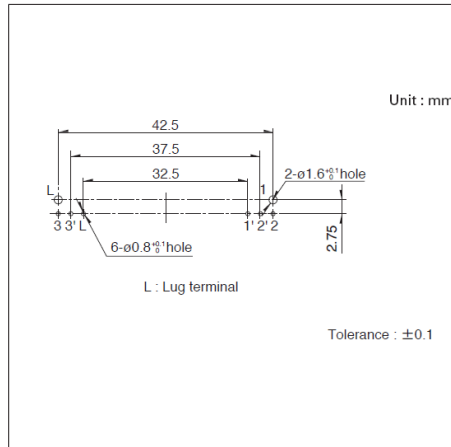

■ Terminal Layout / Circuit Diagram

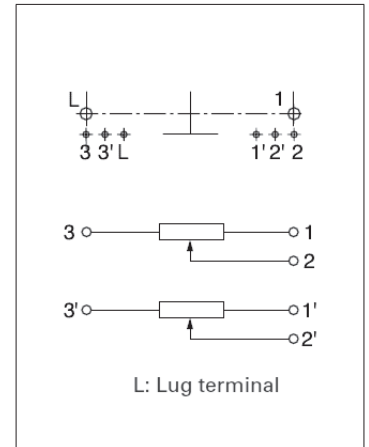

Viewed from mounting side.

Drawing No.10

■ Dimensions

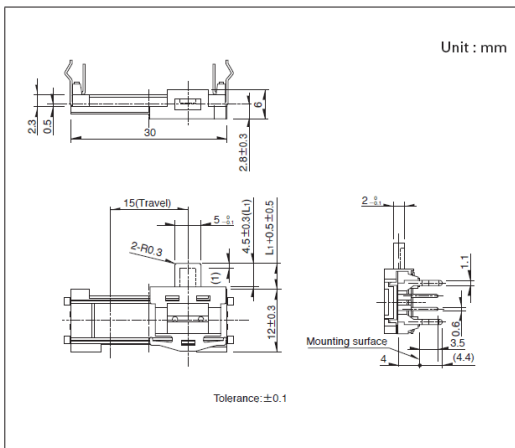

■ Mounting Hole Dimensions

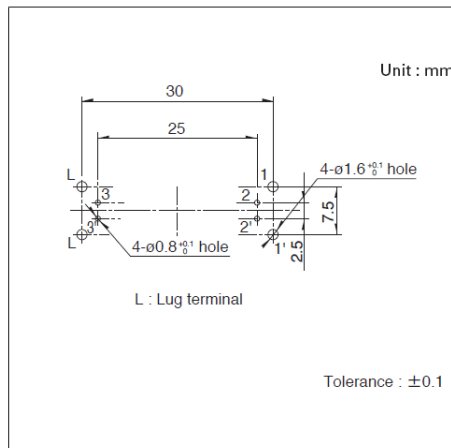

■ Terminal Layout / Circuit Diagram

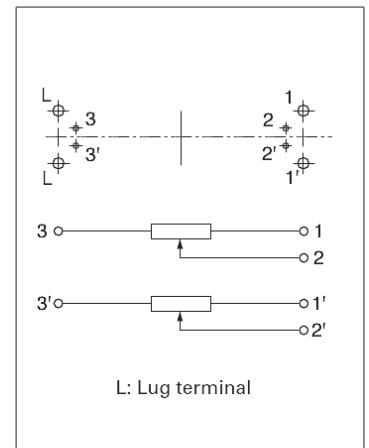

Viewed from mounting side.

Drawing No.11

■ Dimensions

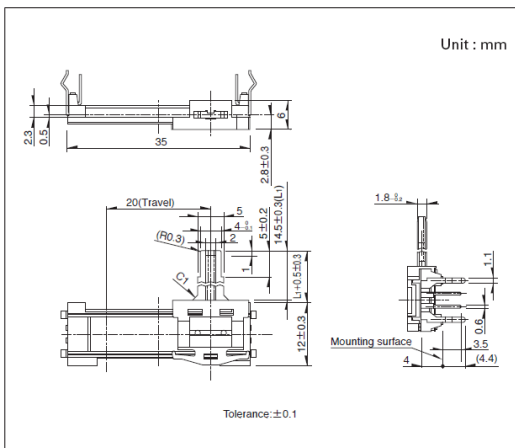

■ Mounting Hole Dimensions

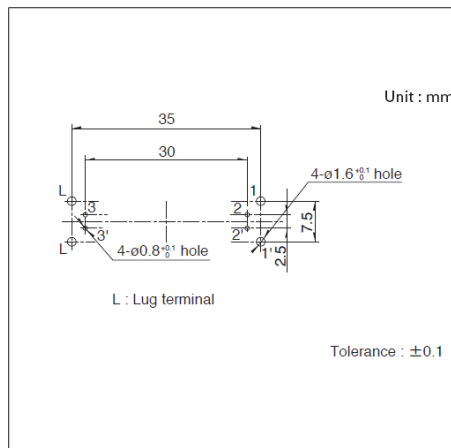

■ Terminal Layout / Circuit Diagram

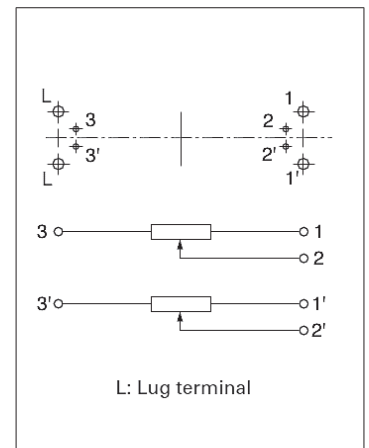

Viewed from mounting side.

Drawing No.12

■ Dimensions

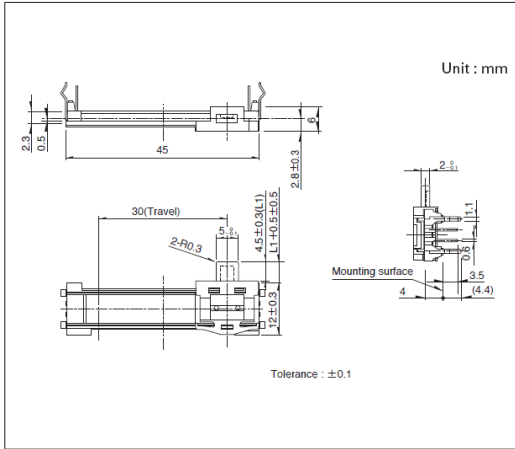

■ Mounting Hole Dimensions

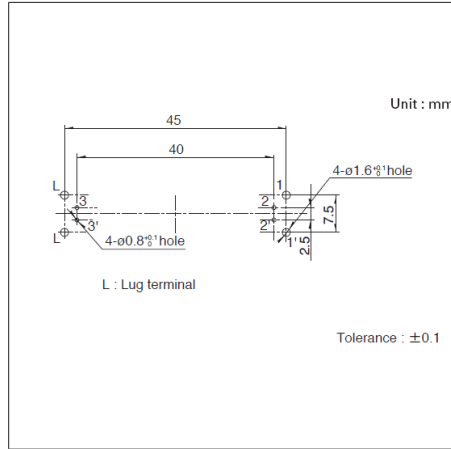

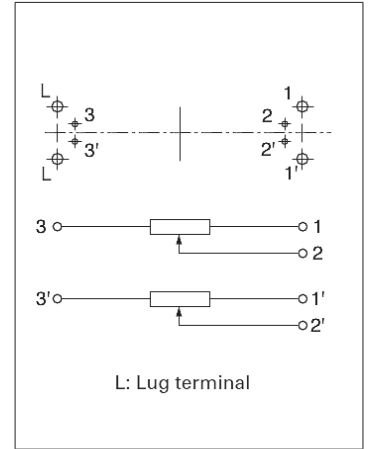

■ Terminal Layout / Circuit Diagram



Viewed from mounting side.

Slide Potentiometer (Master type)

List of Varieties

Series		RS**N	RS6011*P	RSA0V11M
Photo				
Direction of lever	Horizontal	—	—	—
	Vertical	●	●	●
Number of resistor elements		Dual-unit Single-unit		Single-unit
Travel (mm)		60 100	60	100
Lever type		9-T (T-Bar)	6	—
Length of lever (mm)		8.2	15	10.95
Operating temperature range		-10°C to +60°C		
Operating life (cycles)		30,000		100,000
Electrical performance	Total resistance	10kΩ	10kΩ 20kΩ	10kΩ
	Resistance taper	15A	1B 15A	1B
	Total resistance tolerance	±20%		
	Rated power	0.1W 0.25W	0.1W 0.2W	0.5W
	Maximum operating voltage	150V AC 350V AC	150V AC, 10V DC 200V AC, 10V DC	500V AC, 10V DC
	Insulation resistance	100MΩ min. 250V DC		
	Voltage proof	250V AC for 1 minute		
Mechanical performance	Operating force	0.3(+0.5, -0.25)N 0.4(+0.5, -0.35)N	0.5(+1.0, -0.4)N	—
	Stopper strength	100N		10N
	Lever push-pull strength	50N		20N
	Lever wobble (Both side)	1.312mm	2.4mm	1.752mm
	Lever deviation (One side)	0.5mm max.		
Automotive		—	—	—

⚠ Note

● Indicates applicability to all products in the series, while ○ indicates applicability to some products in the series.

Potentiometers Slide Potentiometer (Master type)

Low-profile Master Type (N Fader)

RS**N Series

Thin-profile type with excellent operability, contributing to set design flexibility.



- Total resistance tolerance: $\pm 20\%$
- Operating life: 30,000 cycles
- Operating temperature range: -10°C to $+60^{\circ}\text{C}$

Applications: Audio_TV:Pro audio

Product List

Products No.	Number of resistor elements	Direction of lever	Travel (mm)	Lever type	Length of lever (mm)	Total resistance	Resistance taper	Terminal style	Maximum operating voltage	Automotive	Drawing No.
RS60N111900H	Single-unit	Vertical	60	9-T (T-Bar)	8.2	10k Ω	15A	For PC board	150V AC	—	1
RSA0N111900Q	Single-unit	Vertical	100	9-T (T-Bar)	8.2	10k Ω	15A	For PC board	350V AC	—	2
RS60N1219A04	Dual-unit	Vertical	60	9-T (T-Bar)	8.2	10k Ω	15A	For PC board	150V AC	—	3
RSA0N1219A03	Dual-unit	Vertical	100	9-T (T-Bar)	8.2	10k Ω	15A	For PC board	350V AC	—	4

Note

1. This catalog shows only outline specifications. When using the products, please obtain formal specifications for supply.
2. Place your purchase order in N minimum package units (N: integer).
3. Products other than those listed in above products are also available. Please contact us for details.
4. Please read "Lever Types" for the kinds and code of lever type.

Lever Types

Configuration code	1	4	9-T (T-Bar)
Dimensions			

Packing Specifications

Tray

Products No.	Number of packages (pcs.)		Export package measurements (mm)
	1 case / Japan	1 case / export packing	
RS60N111900H RS60N1219A04	300	600	517 x 377 x 371
RSA0N111900Q RSA0N1219A03	200	400	517 x 377 x 371

Low-profile Master Type (N Fader)
RS**N Series

Drawing No.1

■ Dimensions

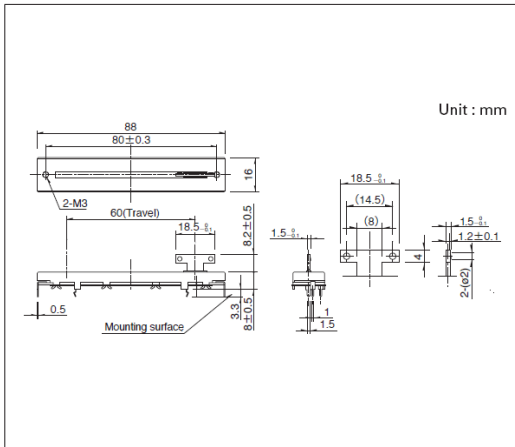

■ Mounting Hole Dimensions

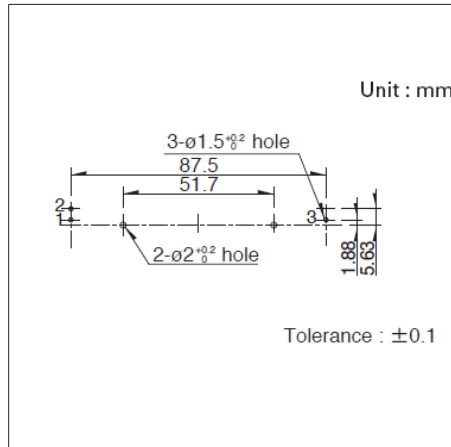

■ Terminal Layout / Circuit Diagram

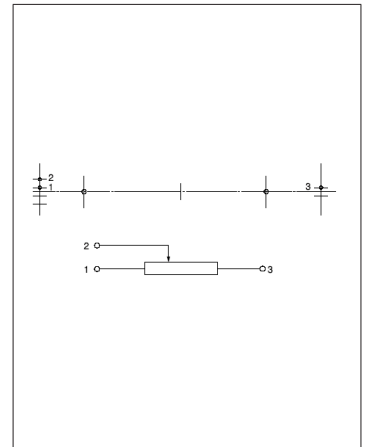

Viewed from mounting side.

Drawing No.2

■ Dimensions

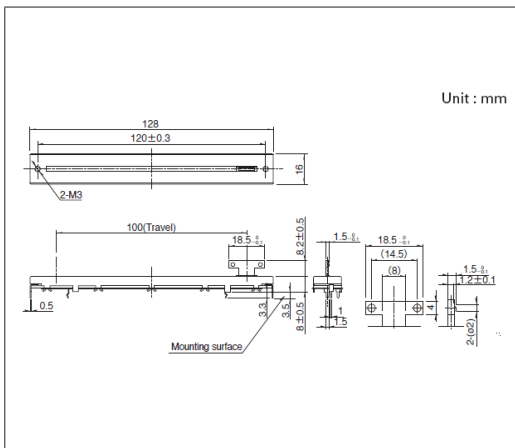

■ Mounting Hole Dimensions

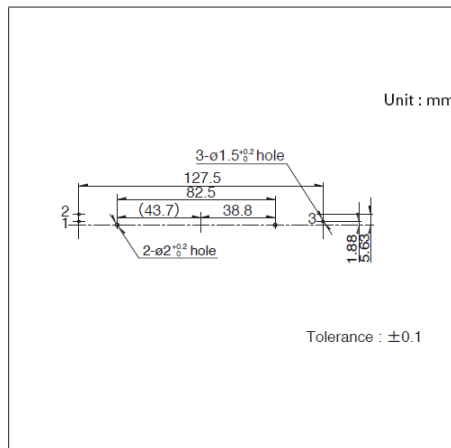

■ Terminal Layout / Circuit Diagram

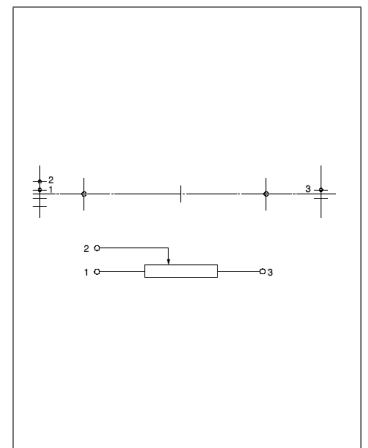

Viewed from mounting side.

Drawing No.3

■ Dimensions

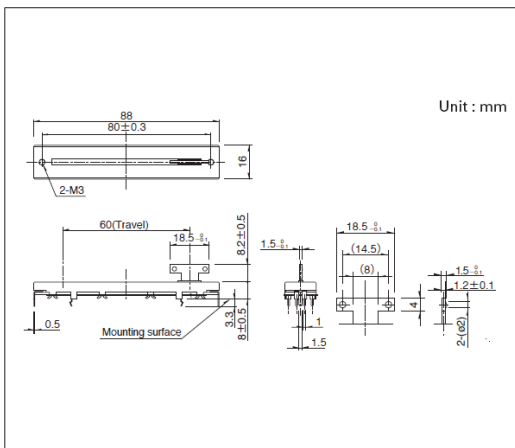

■ Mounting Hole Dimensions

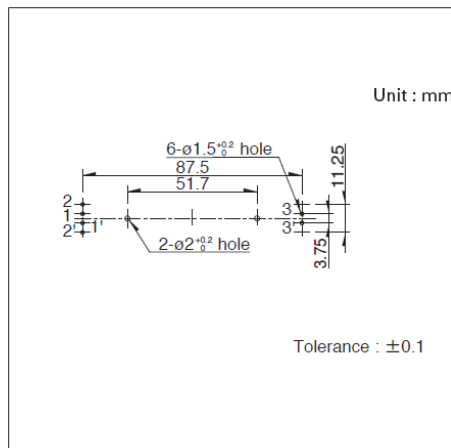

■ Terminal Layout / Circuit Diagram

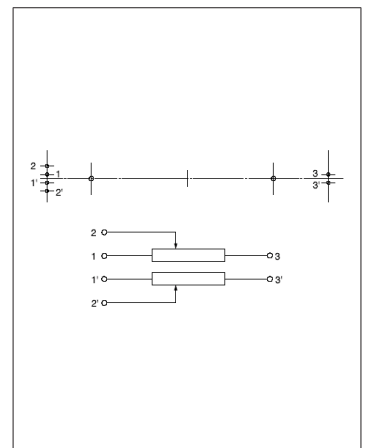

Viewed from mounting side.

Drawing No.4

■ Dimensions

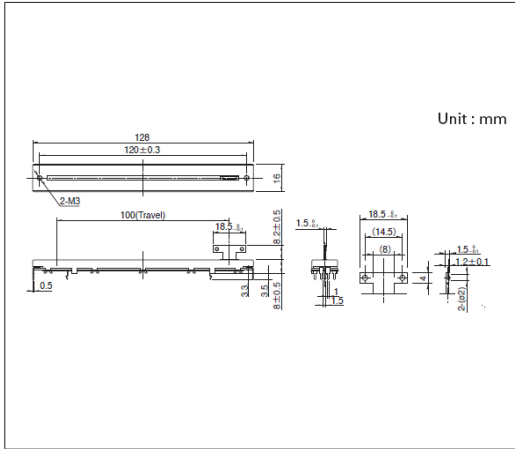

■ Mounting Hole Dimensions

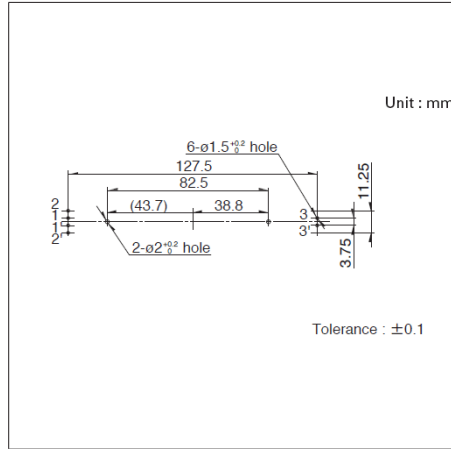

■ Terminal Layout / Circuit Diagram

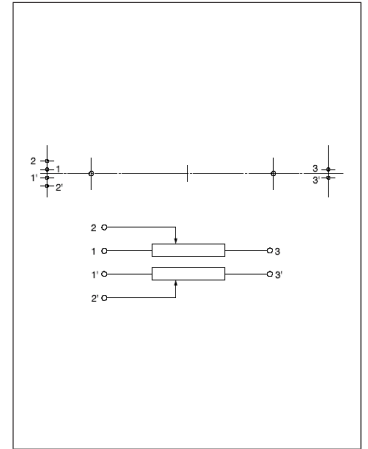

Viewed from mounting side.

Potentiometers Slide Potentiometer (Master type)

Low-profile Master Type (Super P Fader)

RS6011*P Series

Compact design with excellent operation feel, ideal for mixer faders.



- Total resistance tolerance: $\pm 20\%$
- Operating life: 30,000 cycles
- Operating temperature range: -10°C to $+60^{\circ}\text{C}$

Applications: Audio_TV:Pro audio

Product List

Products No.	Number of resistor elements	Direction of lever	Travel (mm)	Lever type	Length of lever (mm)	Total resistance	Resistance taper	Maximum operating voltage	Automotive	Drawing No.
RS6011SP6003	Single-unit	Vertical	60	6	15	10k Ω	1B	200V AC, 10V DC	—	1
RS6011SP6004	Single-unit	Vertical	60	6	15	20k Ω	15A	200V AC, 10V DC	—	
RS6011DP6002	Dual-unit	Vertical	60	6	15	10k Ω	15A	150V AC, 10V DC	—	2
RS6011DP6003	Dual-unit	Vertical	60	6	15	20k Ω	15A	150V AC, 10V DC	—	

Note

1. This catalog shows only outline specifications. When using the products, please obtain formal specifications for supply.
2. Place your purchase order in N minimum package units (N: integer).
3. Products other than those listed in above products are also available. Please contact us for details.
4. Please read "Lever Types" for the kinds and code of lever type.

Lever Types

Configuration code	Unit:mm		
	9-1 (Metal lever)	6 (Metal lever)	4 (Metal lever)
Dimensions			
Length L ₁	10	15	15 20

Packing Specifications

Tray

Number of packages (pcs.)		Export package measurements (mm)
1 case / Japan	1 case / export packing	
900	900	529 x 373 x 273

Potentiometers Slide Potentiometer (Master type)
Low-profile Master Type (Super P Fader)
RS6011*P Series

Drawing No.1

■ Dimensions

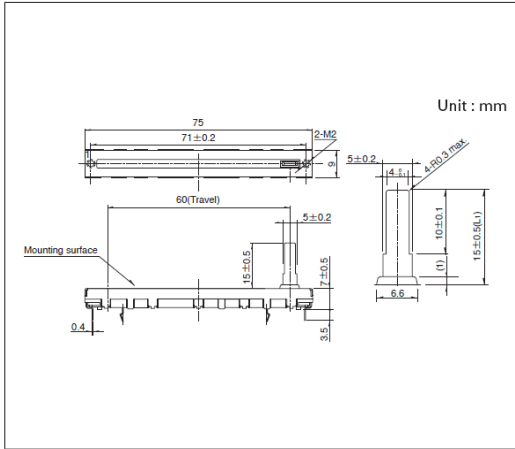

■ Mounting Hole Dimensions

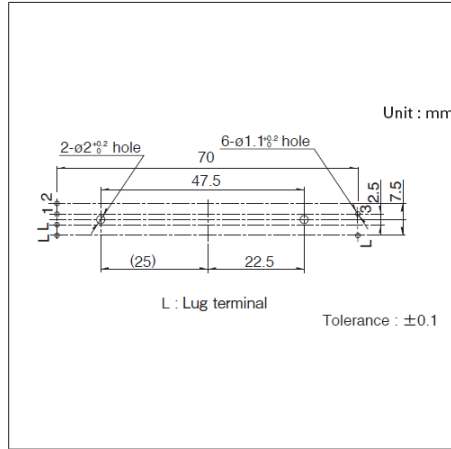

■ Terminal Layout / Circuit Diagram

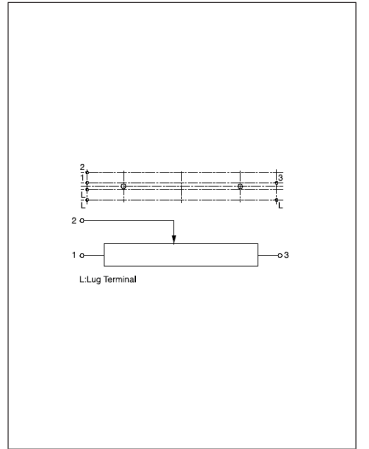

- 1. Viewed from mounting side.
- 2. Lug terminals for terminals '1' '2' '3'.

Drawing No.2

■ Dimensions

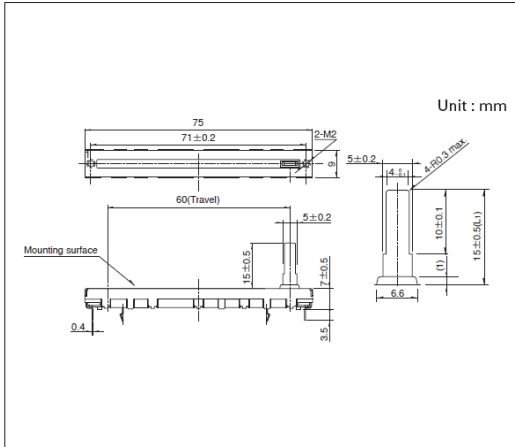

■ Mounting Hole Dimensions

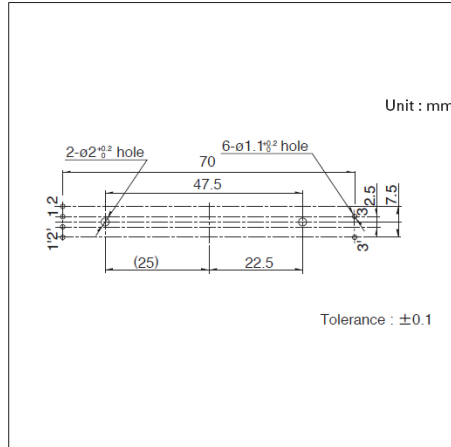

■ Terminal Layout / Circuit Diagram

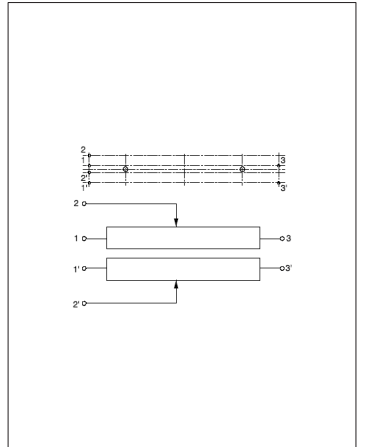

Viewed from mounting side.

Potentiometers Slide Potentiometer (Master type)

Motor-driven Master Type (Motor V Fader)
RSAOV11M Series

Delivers excellent operation feel and high-speed tracking during motor-driven operation.



- Total resistance tolerance: ±20%
- Operating life: 100,000 cycles
- Operating temperature range: -10°C to +60°C

Applications: Audio_TV:Pro audio

■ Product List

Products No.	Number of resistor elements	Direction of lever	Travel (mm)	Length of lever (mm)	Total resistance	Resistance taper	Terminal style	Maximum operating voltage	Automotive	Drawing No.
RSAOV11M9002	Single-unit	Vertical	100	10.95	10kΩ	1B	Connector	500V AC, 10V DC	—	1

⚠ Note

1. This catalog shows only outline specifications. When using the products, please obtain formal specifications for supply.
2. Please place purchase orders per minimum order unit (integer).

■ Packing Specifications

Tray

Number of packages (pcs.)		Export package measurements (mm)
1 case / Japan	1 case / export packing	
80	80	540 x 360 x 205

Drawing No.1

■ Dimensions

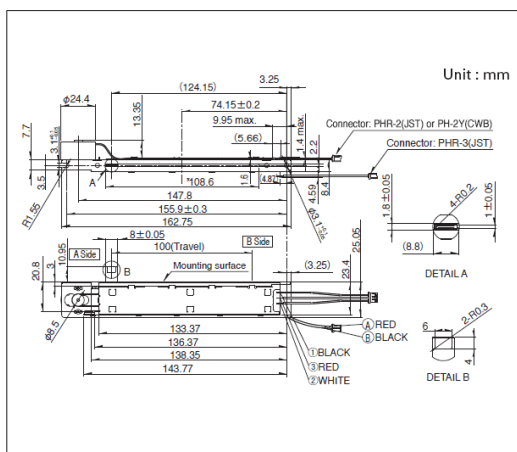

■ Circuit Diagram

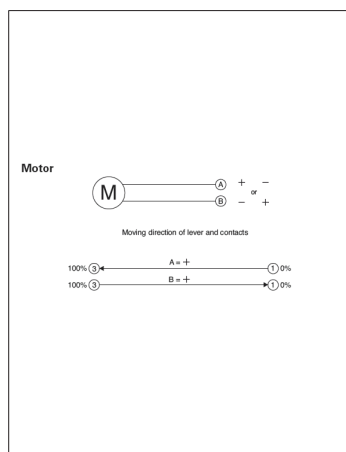

Slide Potentiometers / Soldering Conditions

■ Reference for Manual Soldering

Series	Tip temperature	Duration of Soldering time	No. of solders
RS□□1, RS□□H, RS□□N, RS6011□P	350°C max.	3s max.	1 time

■ Reference for Dip Soldering

Series	Preheating		Dip soldering		Number of soldering
	Soldering surface temperature	Heating time	Soldering temperature	Soldering time	
RS□□1, RS□□H, RS□□N, RS6011□P	100°C max.	1 min. max.	260°C	5s max.	1 time

Potentiometers / Cautions

Recommended Circuit Configuration

Please use the potentiometer in the voltage adjustment circuit (Fig. A). Avoid using it in the current adjustment circuit (Fig. B) as it is affected by the contact resistance between the resistive element and the wiper.

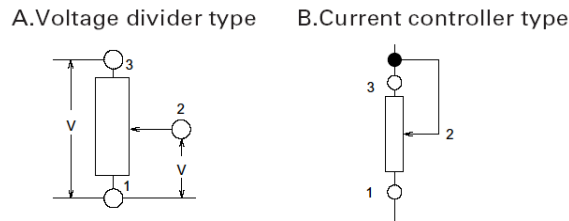

Direct Voltage

When direct voltage is flown through this part, terminal to terminal insulation may deteriorate depending on the use environment. This is due to a migration phenomenon. Contact us if you are planning to use this part under direct voltage.

Impedance on the Output Side

There is a possibility that might be affected by contact resistance of resistive element and wiper in case of low impedance of output side in voltage regulation circuit. For this reason, we require that you adjust to impedance of output side more than 100 times of total resistance.

Residual Resistance

Although electric poles of resistors are generally formed by silver printing, we provide carbon coating over the silver poles to enhance reliability against sulfurization. Contact us if you wish to use the part in a low residual resistance state.

Dew Condensation

Avoid using the potentiometer where dew or water drops might occur on the surface of the resistor, etc. Deterioration of insulation or shorting may occur.

Soldering

To avoid potential contact issues, please do not solder wires to the top surface of the printed circuit board as shown in the diagram.

Solder all metal lugs into a substrate before use.

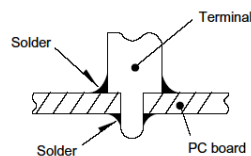

Stress Being Applied to the Terminals

Always pay special attention not to apply excessive stress when handling the terminals. Also, be sure to design appropriate soldering conditions.

Looseness of the Shaft

When lengthy shaft lengths are being employed, the looseness (deviation) tends to grow in proportion to the shaft length. Conducting a test under actual operating conditions is recommended.

Potentiometers / Cautions

Chassis Mounting

The use of a nut to fasten this part may lead to excessive tightening and can deteriorate the rotary contact performance, or strip the threads. Handle with care when tightening the nut.

Use of Chemicals

Since synthetic resins such as polycarbonate are being used as the material for the insulated type shafts, avoid using this part under gassy environments of such chemicals as ammonia, amines, alkali water solutions, aromatic hydrocarbons, ketones, esters and halogenated hydrocarbons, especially, under their intensive gas environments.

Operation at Low Temperature

When these products are expected to be used under low temperature environments such as applications for car radios and car stereos, we can customize them for easier and more smooth rotary movements. When placing orders, indicate whether the low temperature specification is necessary or not.

Storage

1. Store the products as delivered, at a normal temperature and humidity, without direct sunshine and corrosive gas ambient. Use them at an earliest possible timing, not later than six months upon receipt.
2. After breaking the seal, keep the products in a plastic bag to shut out ambient air, store them in the same environment as above, and use them up as soon as possible.
3. Do not stack too many switches.

The above operation notes are quoted from the "Precaution and Guideline of Potentiometer for Electrical Devices", which is a technical report issued by the Japan Electronics and Information Technology Industries Association RCR-2191A (in March 2002).

For details, see the above technical report.



Multi Control Devices

● Potentiometer Type ————— 448

● Switch Type ————— 453

Potentiometer Type

List of Varieties

Series		RKJXV	RKJX2
Photo			
Dimensions (mm)		17.8×21.3×11.2 18.2×21.7×11.2	13.7×14.6×7.8 (Not including FPC)
Directional resolution		Continuous	
Lever return mechanism		With	
Operating temperature range		-10°C to +70°C	-10°C to +50°C
Operating life (cycles)	Directions	2,000,000	
	Center push	500,000	
Potentiometer part	Maximum operating voltage	5V DC 50V AC, 5V DC	5V DC
	Operating angle	Each direction 23° max.	
	Resistance taper	B	
	Total resistance	10kΩ	5kΩ
Center push part	Center push	With Without	With
	Ratings (max.)	50mA 12V DC	1mA 5V DC
	Travel (mm)	0.4(+0.5, -0.3)	0.35(+0.5, -0.25)
Electrical performance	Insulation resistance	100MΩ min. 250V DC	
	Voltage proof	250V AC for 1 minute	
	Rated power	0.0125W	
	Slider noise	300mV p-p max. by JIS method	
Mechanical performance	Directional operating force	14±10mN·m	7(+5, -3)mN·m
	Push operating force	7.4±3N	6.0±2.5N
	Lever return precision	±5°	
	Actuator strength Push/pull directions	98N min. (Push), 50N min. (Pull)	
Environmental performance	Cold	-30°C 96h	
	Dry heat	80°C 96h	
	Damp heat	60°C, 90 to 95%RH 96h	
Automotive		—	—

Drawing No.2

■ Dimensions

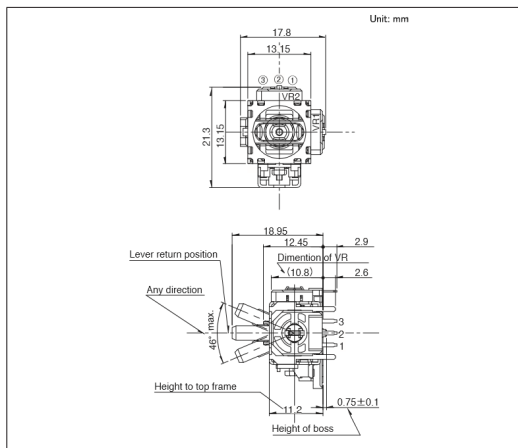

■ Mounting Hole Dimensions

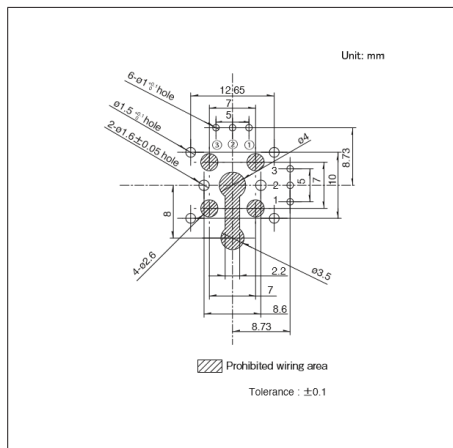

Viewed from mounting side.

Multi Control Devices Potentiometer Type

ThumbPointer™ (Stick Controller)
RKJX2 Series

Compact, thin-profile variable resistor device with a body height of 7.8mm, featuring a lever return mechanism.



- Directional resolution: Continuous
- Rated power: 0.0125W
- Operating temperature range: -10°C to +50°C

Applications: Energy_Industrial: Robots, drones, Industrial equipment
Game: Home handheld consoles, Virtual/augmented reality

■ Product List

Products No.	Lever return mechanism	Potentiometer part				Center push part			Dimensions (W×D×H) (mm)	Automotive	Drawing No.
		Maximum operating voltage	Operating angle	Resistance taper	Total resistance	Center push	Ratings (max.)	Travel (mm)			
RKJX21224001	With	5V DC	Each direction 23° max.	B	5kΩ	With	1mA 5V DC	0.35(+0.5, -0.25)	13.7×14.6×7.8 (Not including FPC)	—	1

⚠ Note

1. This catalog shows only outline specifications. When using the products, please obtain formal specifications for supply.
2. Please place purchase orders per minimum order unit (integer).

■ Packing Specifications

Tray

Number of packages (pcs.)		Export package measurements (mm)
1 case / Japan	1 case / export packing	
1,484	1,484	544×364×178

Drawing No.1

■ Dimensions

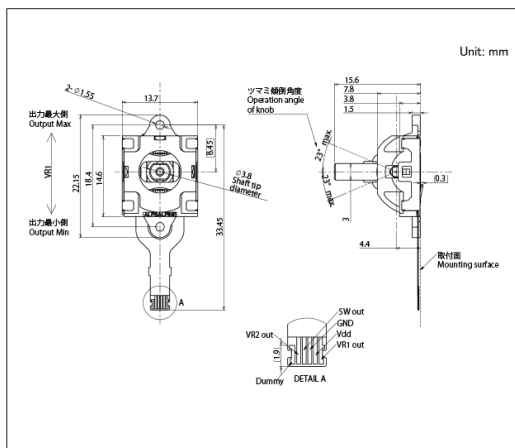

Potentiometer Type Multi Control Devices / Soldering Conditions

■ Reference for Manual Soldering

Series	Tip temperature	Soldering time	No. of solders
RKJXV	350°C max.	3s max.	1 time

■ Reference for Dip Soldering

Series	Preheating		Dip soldering		No. of solders
	Soldering surface temperature	Heating time	Soldering temperature	Soldering time	
RKJXV	90 ~ 120°C	60s max.	260°C	5s	1 time

Potentiometer Type Multi Control Devices / Cautions

Circuit Used for Analog Stick Controller

Please use in the voltage adjustment circuit (Fig. A).

Impedance on the Output Side

Since this product is designed to use with its output is connected directly to A/D port. Impedance is considered to be mega ohm level. Then contact resistance in the product is higher. Please refer to Fig-1. So when you use it in the circuit like Fig-2. Please make sure that impedance should be over than 1M-ohm.

Dew Condensation

Avoid using the product when condensation or drops of water might occur inside the product. Otherwise, insulation deterioration or shorting may occur.

Soldering

To avoid potential contact issues, please do not solder wires to the top surface of the printed circuit board as shown in the diagram.

Solder all metal lugs into a substrate before use.

Stress Being Applied to the Terminals

Always be careful not to apply excessive stress on the terminals. Design appropriate soldering conditions.

Handling of Variable Resistors Equipped with Switches

Exercise care when packing or storing. Packaging or storing while load is applied to the shaft may cause a malfunction in performance.

Storage

1. Store the products as delivered, at a normal temperature and humidity, without direct sunshine and corrosive gas ambient. Use them at an earliest possible timing, not later than six months upon receipt.
2. After breaking the seal, keep the products in a plastic bag to shut out ambient air, store them in the same environment as above, and use them up as soon as possible.
3. Do not stack too many switches.

The above operation notes are quoted from the "Precaution and Guideline of Potentiometer for Electrical Devices", which is a technical report issued by the Japan Electronics and Information Technology Industries Association EIAJ RCR-2191A (in March 2002).

For details, see the above technical report.

A.Voltage divider type

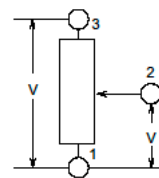

[Fig.1]

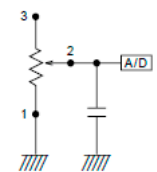



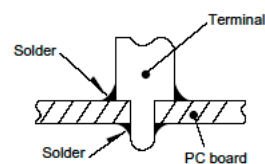
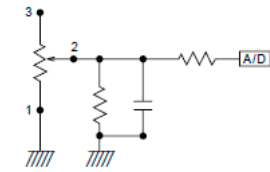



[Fig.2]



Switch Type

List of Varieties

Series		RKJXT1F	RKJXM1	SKRH	SRBE	SLLB	SLLB5	
Photo								
Dimensions (mm)		17.0×17.0×10.5	11.0×11.0×6.6	7.35×7.5×1.8 7.45×7.5×1.85	8.05×11×2.35	11.8×11.4×3.0	9.5×8.8×2.2	
Directional resolution		4-direction	8-direction	4-direction	—	2-direction		
Operating temperature range		-40°C to +85°C			-10°C to +60°C	-40°C to +85°C	-10°C to +60°C	
Rating (max.)		10mA 5V DC		50mA 12V DC	1mA 5V DC	10mA 5V DC		
Durability	Operating life	Directions	Total with 4-direction 50,000 cycles	Total with 8-direction 100,000 cycles	—			
		Center push	50,000 cycles	100,000 cycles	200,000 cycles 1,000,000 cycles	100,000 cycles	—	
		Encoder	15,000 cycles	—	100,000 cycles	—	—	
	Operating life without load	—			100,000 cycles			
	Operating life with load (Load: as ratings)	—			100,000 cycles (10mA 5V DC)			
Electrical performance	Insulation resistance	100MΩ min. 250V DC		100MΩ min. 100V DC	10MΩ min. 50V DC	100MΩ min. 100V DC		
	Voltage proof	300V AC for 1 minute or 360V AC for 2s		100V AC for 1 minute	50V AC for 1 minute	100V AC for 1 minute		
Mechanical performance	Directional operating force	40±25mN-m	Direction A, B, C, D 30±20mN-m Direction AB, BC, CD, DA 25±20mN-m	1.2±0.69N 1.23±0.69N	—	0.65±0.3N		
	Push operating force	5±2N	3±1.5N	2.35±0.69N	3.5±1.5N	2±1N	2.5±1N	
	Actuator strength	Push/pull directions	100N (Push/Pull)	100N (Push), 50N (Pull)	—	50N		
		Operating direction	0.4N-m	0.3N-m	29.4N	—	10N	
Environmental performance	Cold	-40°C 500h		-40°C 96h	-30°C 96h	-40°C 96h	-20°C 96h	
	Dry heat	85°C 500h		90°C 96h	85°C 96h			
	Damp heat	60°C, 90 to 95%RH 500h		60°C, 90 to 95%RH 96h	40°C, 90 to 95%RH 96h			
Automotive		●	●	—	—	—	—	

⚠ Note

● Indicates applicability to all products in the series, while ○ indicates applicability to some products in the series.

Multi Control Devices **Switch Type**

4-directional Stick Switch (with Encoder + Center-push Function)
RKJXT1F Series

Automotive-compatible multifunctional device with a 17×17mm round body, offering 1-axis 4-direction/push/encoder functions.



- Directional resolution: 4-direction
- Ratings (max.) (Resistive load): 10mA 5V DC
- Operating temperature range: -40°C to +85°C

Applications: Audio_TV: Visual
 Automotive: Navigation/audio systems, HVAC

■ Product List

Products No.	Stick switches		Encoder		Dimensions (W×D×H) (mm)	Automotive	Drawing No.
	Operating angle (Directions)	Travel (Center push) (mm)	Number of detent	Number of pulse			
RKJXT1F42001	Each direction 9°max.	0.3±0.2	30	15	17.0×17.0×10.5	●	1

⚠ Note

1. This catalog shows only outline specifications. When using the products, please obtain formal specifications for supply.
2. Please place purchase orders per minimum order unit (integer).

■ Packing Specifications

Tray

Number of packages (pcs.)		Export package measurements (mm)
1 case / Japan	1 case / export packing	
1,320	2,640	555×375×333

Drawing No.1

■ Dimensions

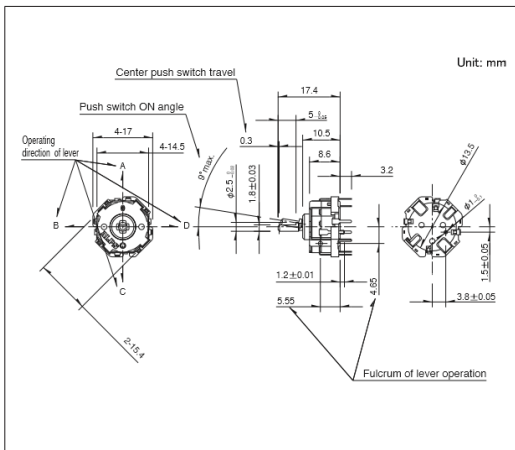

■ Mounting Hole Dimensions

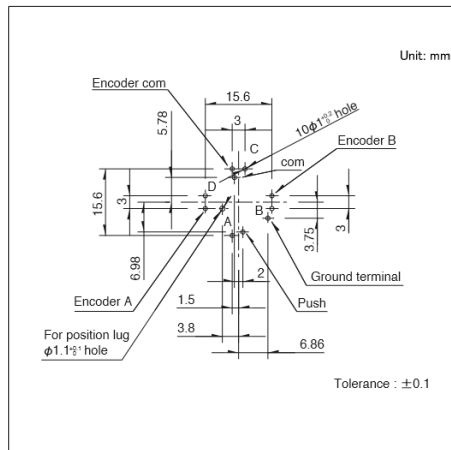

Viewed from mounting side.

■ Circuit Diagram

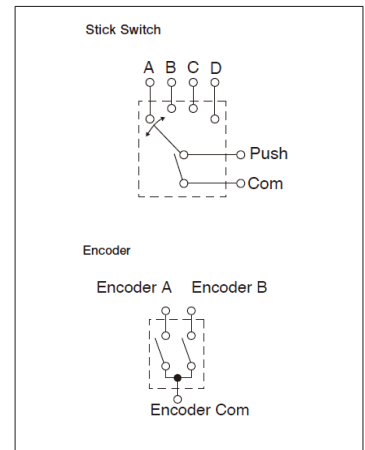

Multi Control Devices **Switch Type**

8-direction Stick Switch (with Center-push Function)
RKJXM Series

Automotive-compatible multifunctional switch with an 11×11mm round body, offering 1-axis 8-direction operation with tactile feedback.



- Directional resolution: 8-direction
- Ratings (max.) (Resistive load): 10mA 5V DC
- Operating temperature range: -40°C to +85°C

Applications: Audio_TV: Visual
Automotive: Navigation/audio systems, HVAC

■ Product List

Products No.	Operating angle (Directions)	Travel (Center push) (mm)	Dimensions (W×D×H) (mm)	Automotive	Drawing No.
RKJXM1015004	A, B, C, D direction: 10°max. AB, BC, CD, DA direction: 12°max.	0.3±0.2	11.0×11.0×6.6	●	1

Note

1. This catalog shows only outline specifications. When using the products, please obtain formal specifications for supply.
2. Please place purchase orders per minimum order unit (integer).

■ Packing Specifications

Tray

Number of packages (pcs.)		Export package measurements (mm)
1 case / Japan	1 case / export packing	
1,000	2,000	405×290×200

Drawing No. 1

■ Dimensions

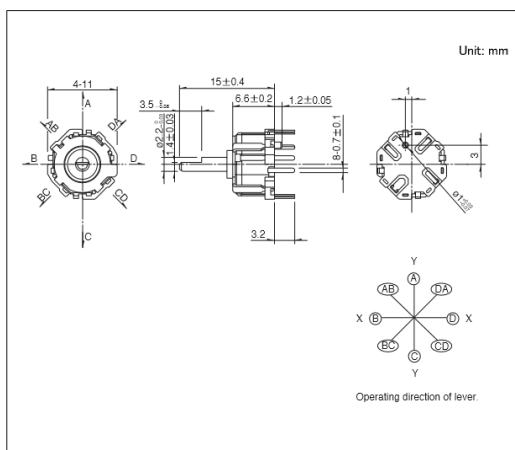

■ Mounting Hole Dimensions

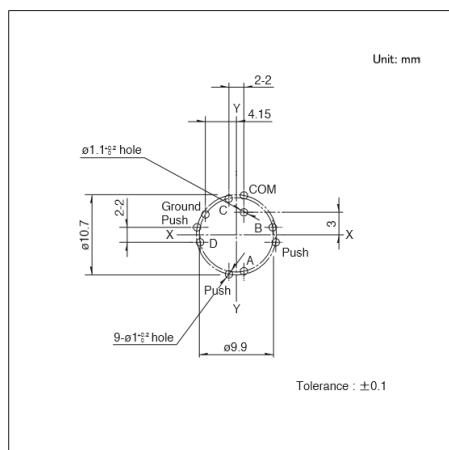

■ Circuit Diagram

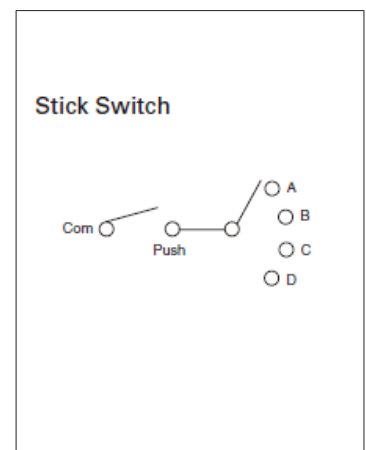

Viewed from mounting side.

Multi Control Devices **Switch Type**

4-direction Type with Center-push Function (Surface Mount)

SKRH Series

Body thickness of 1.85mm with a long-life rating of 1 million cycles.



- Directional resolution: 4-direction
- Ratings (max.)/(min.) (Resistive load): 50mA 12V DC/10μA 1V DC
- Operating temperature range: -40°C to +85°C

Applications: Game: Home handheld consoles, Virtual/augmented reality

■ Product List

Products No.	Operating force		Travel		Operating life (5mA 5V DC) (cycles)	Initial contact resistance	Stem color	Guide bosses	Dimensions (W×D×H) (mm)	Automotive	Drawing No.
	4-direction (N)	Center push (N)	4-direction (mm)	Center push (mm)							
SKRHAAE010	1.23	2.35	0.25	0.15	200,000 for each direction	500mΩ max.	Black	Without	7.35×7.5×1.8	—	1
SKRHABE010	1.23	2.35	0.25	0.15	200,000 for each direction	500mΩ max.	Black	With	7.35×7.5×1.8	—	2
SKRHACE010	1.2	2.35	0.25	0.15	1,000,000 for each direction	100mΩ max.	Natural	Without	7.45×7.5×1.85	—	3
SKRHAE010	1.2	2.35	0.25	0.15	1,000,000 for each direction	100mΩ max.	Natural	With	7.45×7.5×1.85	—	4

⚠ Note

1. This catalog shows only outline specifications. When using the products, please obtain formal specifications for supply.
2. 4-directional operating force and travel are measured at 4.3mm height from the bottom of the switch.
3. Please place purchase orders for taping products per minimum order unit (1 reel or a case).

■ Packing Specifications

Taping

Number of packages (pcs.)			Tape width (mm)	Export package measurements (mm)
1 reel	1 case / Japan	1 case / export packing		
1,300	10,400	10,400	16	395×395×205

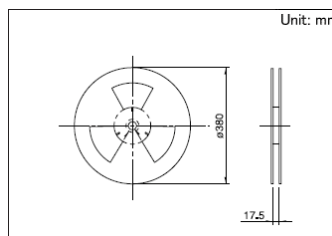

Drawing No. 1

■ Dimensions

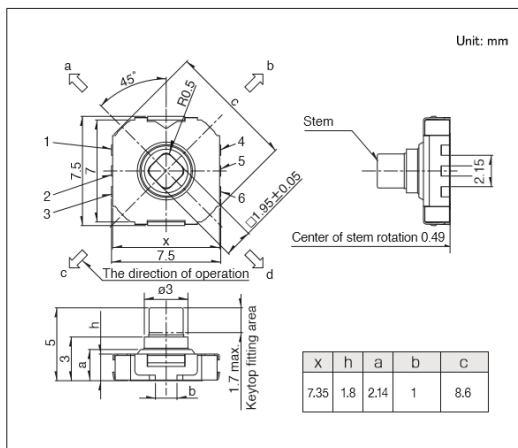

■ Land Dimensions

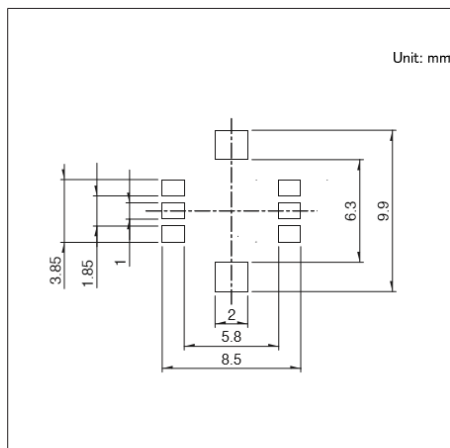

■ Circuit Diagram

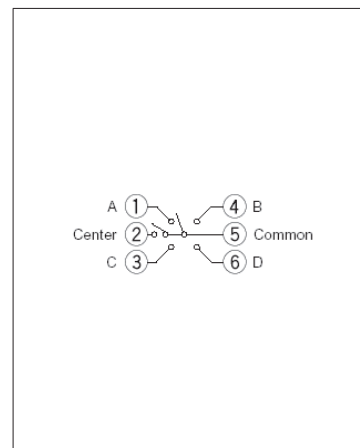

Viewed from mounting face.

4-direction Type with Center-push Function (Surface Mount)
SKRH Series

Drawing No.2

■ Dimensions

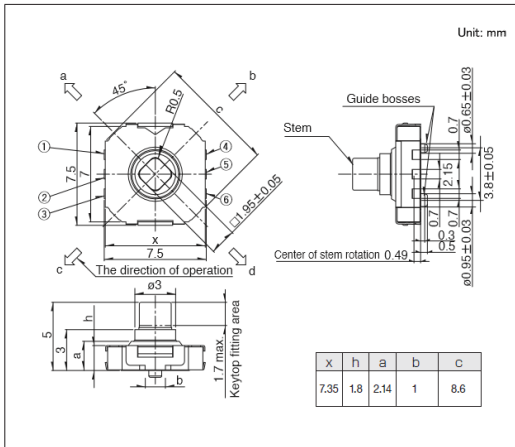

■ Land Dimensions

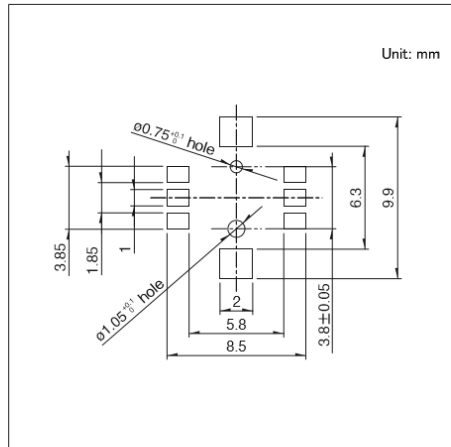

■ Circuit Diagram

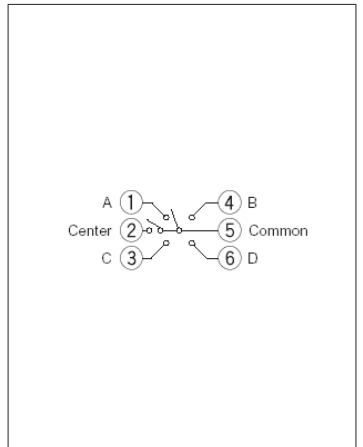

Drawing No.3

■ Dimensions

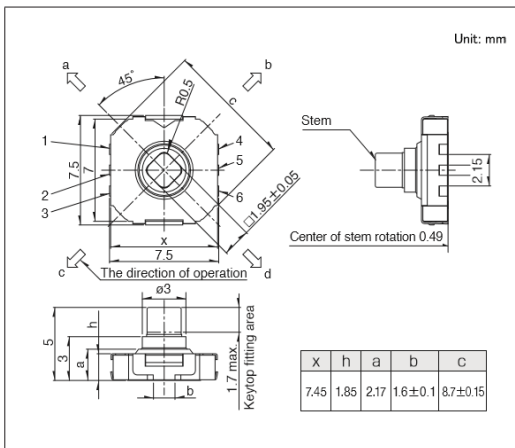

■ Land Dimensions

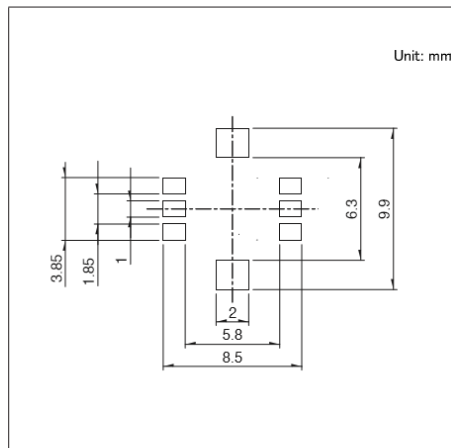

■ Circuit Diagram

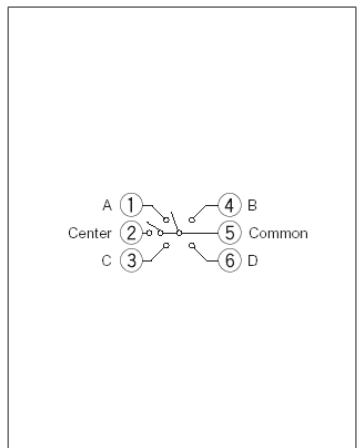

Drawing No.4

■ Dimensions

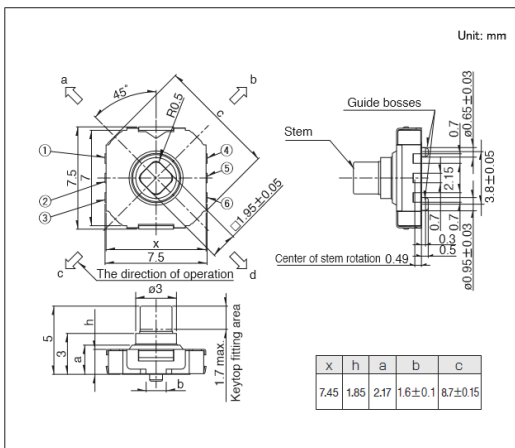

■ Land Dimensions

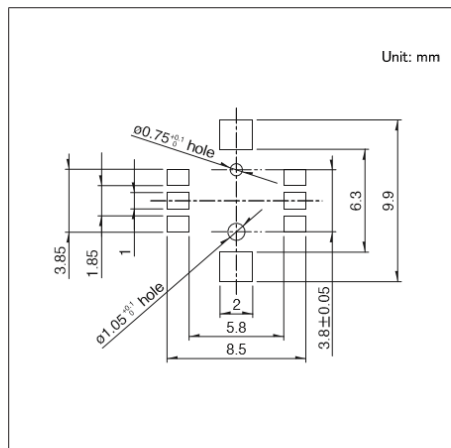

■ Circuit Diagram

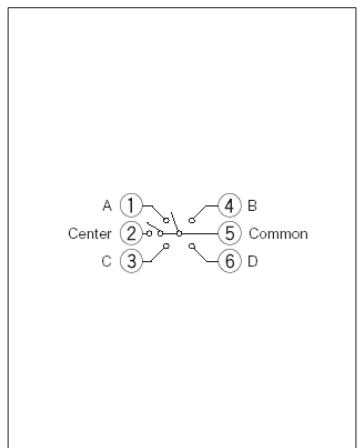

Multi Control Devices **Switch Type**

Encoder and Push Operation Type
SRBE Series

Compact, multifunctional operation device utilizing side space of the set.

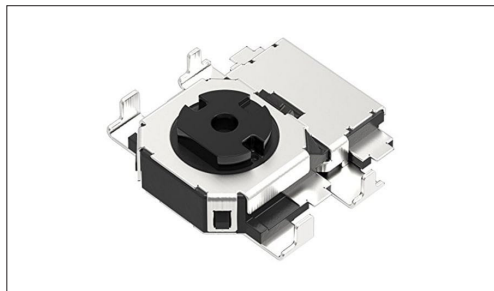

- Directional resolution:-
- Ratings (max.)/(min.) (Resistive load): 1mA 5V DC/50μA 3V DC
- Operating temperature range:-10°C to +60°C

Applications: Game: Home handheld consoles, Virtual/augmented reality

■ Product List

Products No.	Number of detent	Number of pulse	Operating direction	Mounting method	Travel (Push operation)	Dimensions (W×D×H) (mm)	Automotive	Drawing No.
SRBE110301	12	6	Horizontal	Standard	0.2mm	8.05×11×2.35	—	1
SRBE210200	12	6	Horizontal	Low-profile	0.2mm	8.05×11×2.35	—	2

⚠ Note

1. This catalog shows only outline specifications. When using the products, please obtain formal specifications for supply.
2. Please place purchase orders for taping products per minimum order unit (1 reel or a case).

■ Packing Specifications

Taping

Number of packages (pcs.)			Tape width (mm)	Export package measurements (mm)
1 reel	1 case / Japan	1 case / export packing		
1,500	3,000	6,000	24	428×413×172

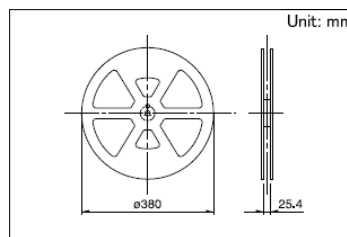

Drawing No.1

■ Dimensions

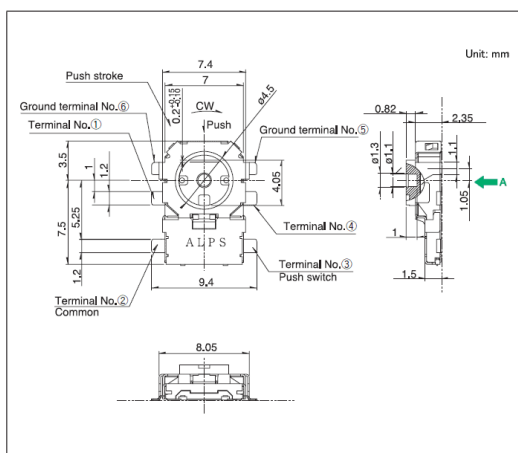

■ Land Dimensions

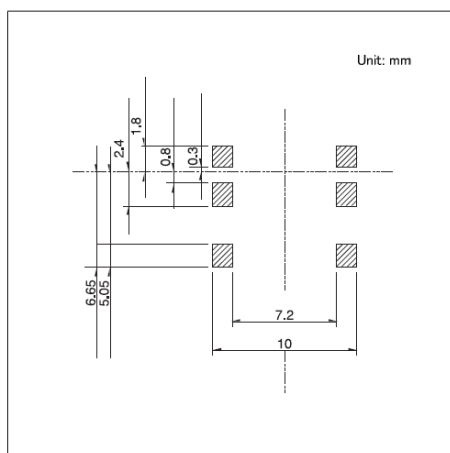

■ Circuit Diagram

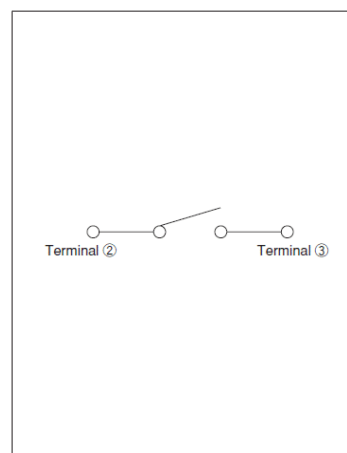

Viewed from direction A in the dimensions.

Multi Control Devices **Switch Type**

Lever and Push Operation Type
SLLB Series

Compact, thin-profile horizontal type suitable for a wide range of applications.

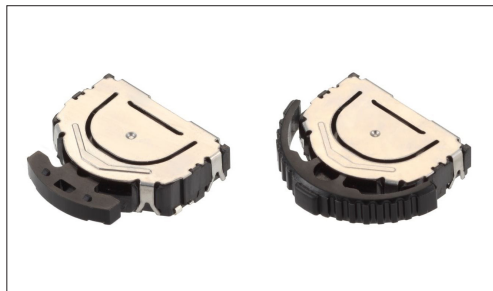

- Directional resolution: 2-direction
- Ratings (max.)/(min.) (Resistive load): 10mA 5V DC/50μA 3V DC
- Operating temperature range: -40°C to +85°C

Applications: Audio_TV:Cameras

■ Product List

Products No.	Actuator configuration	Push-on switch	Operating force		Travel (Center push) (mm)	Location lug	Dimensions (W×D×H) (mm)	Automotive	Drawing No.
			Lever portion	Push portion					
SLLB120100	Mounting knob	With	0.65±0.3N	2±1N	Refer to the dimensions	With	11.8×11.4×3.0	—	1
SLLB120200	Mounting knob integrated	With	0.65±0.3N	2±1N	Refer to the dimensions	With	11.8×11.4×3.0	—	2
SLLB120300	Mounting knob integrated	With	0.65±0.3N	2±1N	Refer to the dimensions	With	11.8×11.4×3.0	—	

⚠ Note

1. This catalog shows only outline specifications. When using the products, please obtain formal specifications for supply.
2. Please place purchase orders for taping products per minimum order unit (1 reel or a case).

■ Packing Specifications

Taping

Number of packages (pcs.)			Tape width (mm)	Export package measurements (mm)
1 reel	1 case / Japan	1 case / export packing		
1,350	2,700	5,400	24	428×413×172

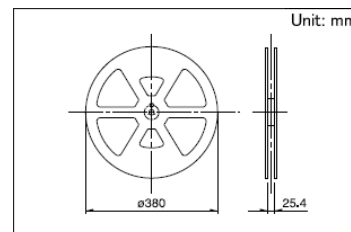

Drawing No. 1

■ Dimensions

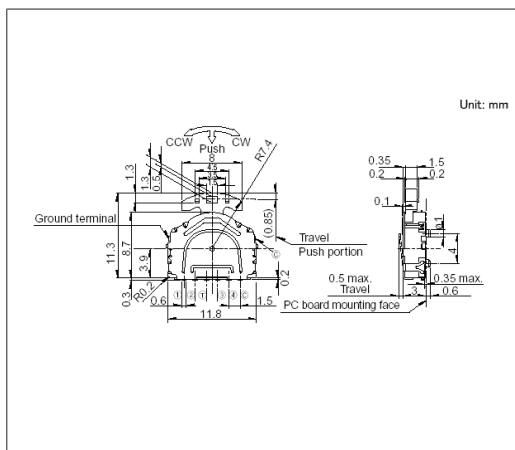

■ Land Dimensions

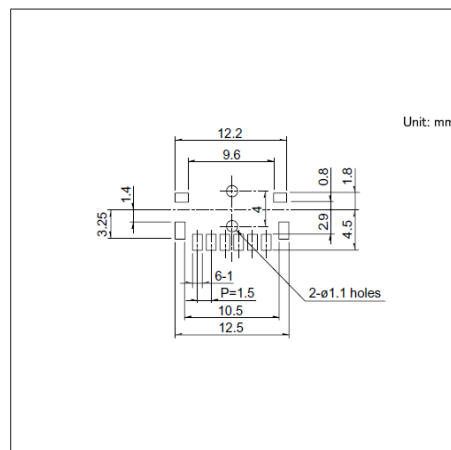

Viewed from mounting face.

■ Circuit Diagram

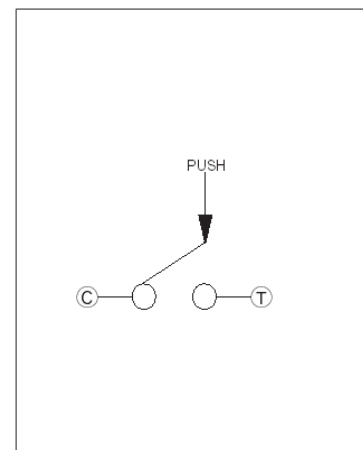

Push portion.

Drawing No.2

■ Dimensions

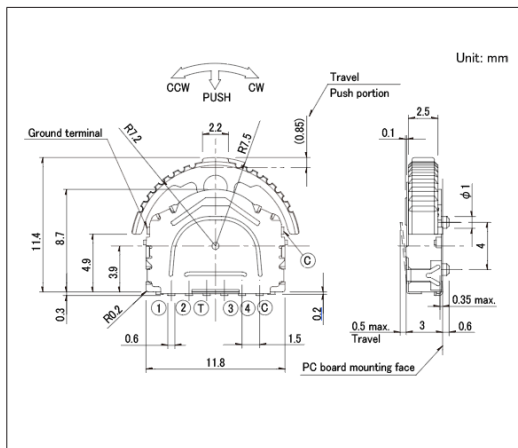

■ Land Dimensions

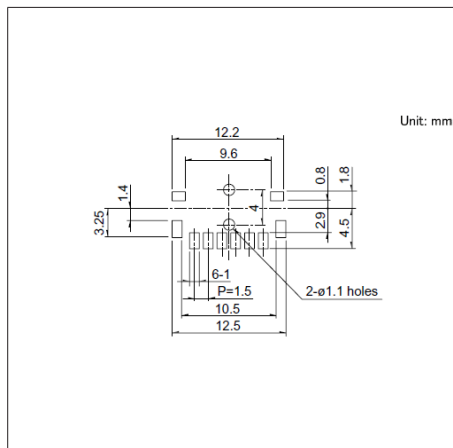

Viewed from mounting face.

■ Circuit Diagram

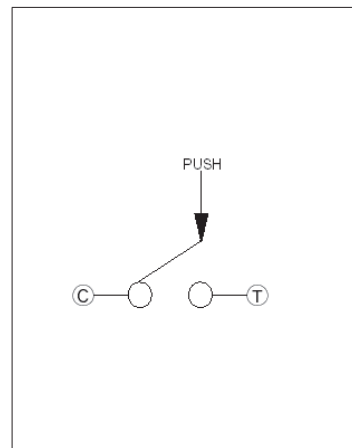

Push portion.

Multi Control Devices **Switch Type**

Lever and Push Operation Type
SLLB5 Series

Two-direction input device reduced to 50% of the projected area compared to conventional products.



- Directional resolution: 2-direction
- Ratings (max.)/(min.) (Resistive load): 10mA 5V DC/50μA 3V DC
- Operating temperature range: -10°C to +60°C

Applications: Audio_TV:Cameras

■ Product List

Products No.	Actuator configuration	Push-on switch	Operating force		Travel (Center push) (mm)	Location lug	Dimensions (W×D×H) (mm)	Automotive	Drawing No.
			Lever portion	Push portion					
SLLB510100	Mounting knob integrated	With	0.65±0.3N	2.5±1N	0.7	With	9.5×8.8×2.2	—	1
SLLB510200	Mounting knob integrated	With	0.65±0.3N	2.5±1N	0.7	Without	9.5×8.8×2.2	—	2
SLLB520100	Mounting knob	With	0.65±0.3N	2.5±1N	0.7	With	9.5×8.8×2.2	—	3
SLLB520200	Mounting knob	With	0.65±0.3N	2.5±1N	0.7	Without	9.5×8.8×2.2	—	4

⚠ Note

1. This catalog shows only outline specifications. When using the products, please obtain formal specifications for supply.
2. Please place purchase orders for taping products per minimum order unit (1 reel or a case).

■ Packing Specifications

Taping

Number of packages (pcs.)			Tape width (mm)	Export package measurements (mm)
1 reel	1 case / Japan	1 case / export packing		
1,500	3,000	6,000	24	428×413×172

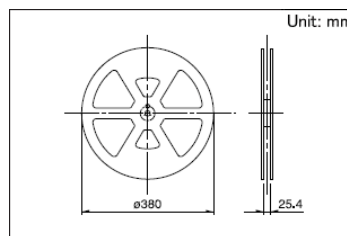

Drawing No.1

■ Dimensions

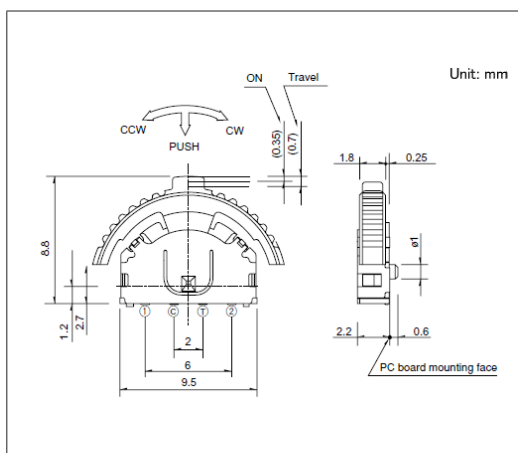

■ Land Dimensions

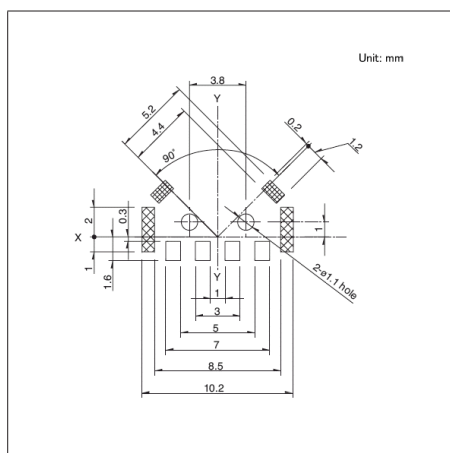

Viewed from mounting face.

■ Circuit Diagram

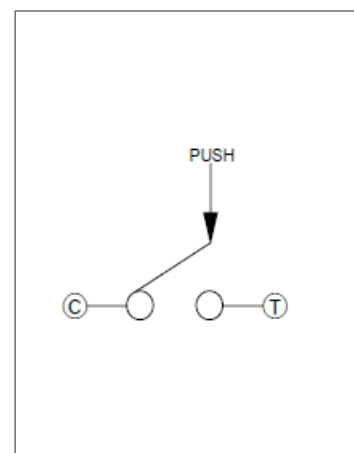

Push portion.

Drawing No.2

■ Dimensions

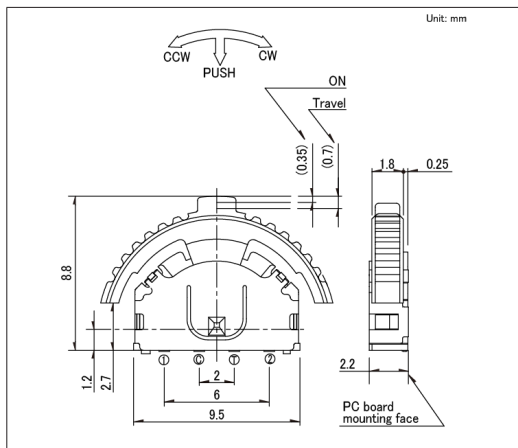

■ Land Dimensions

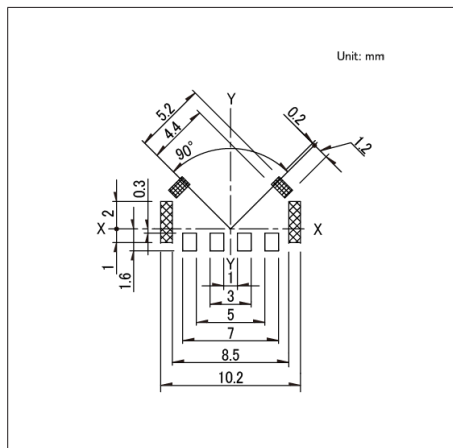

■ Circuit Diagram

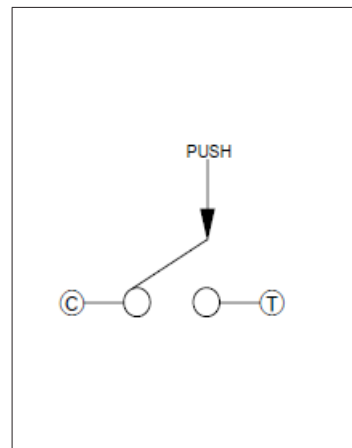

Viewed from mounting face.

Push portion.

Drawing No.3

■ Dimensions

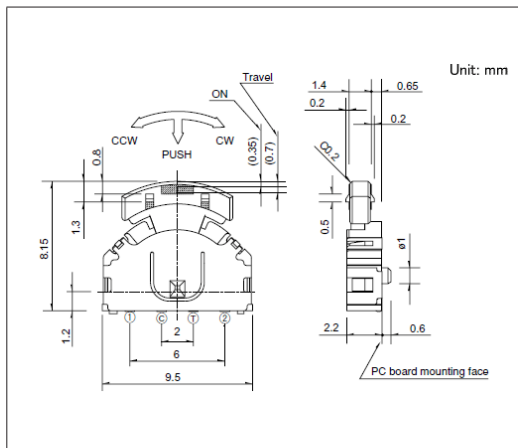

■ Land Dimensions

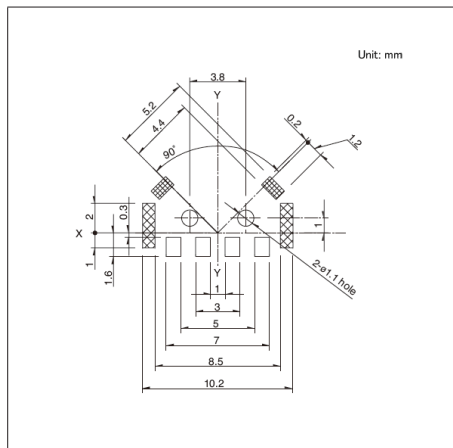

■ Circuit Diagram

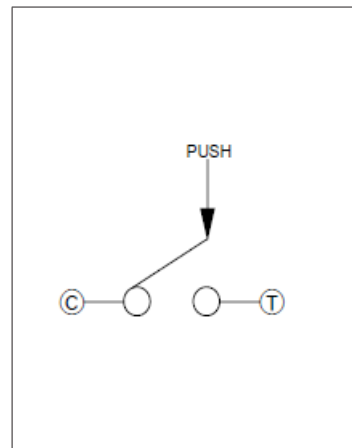

Viewed from mounting face.

Push portion.

Drawing No.4

■ Dimensions

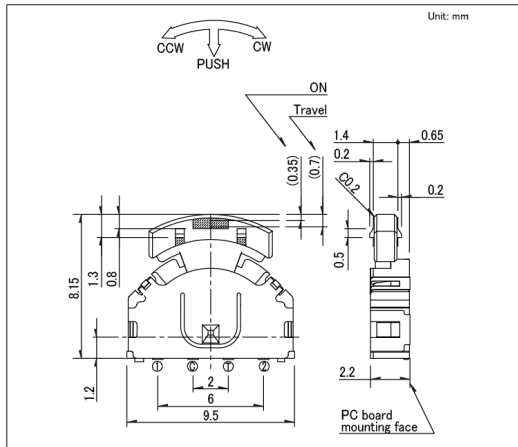

■ Land Dimensions

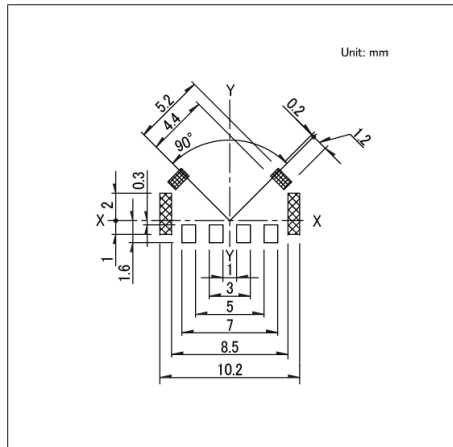

■ Circuit Diagram

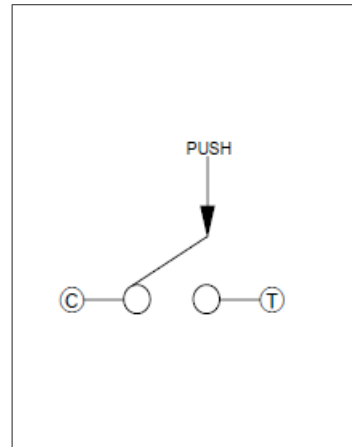

Viewed from mounting face.

Push portion.

Switch Type Multi Control Devices / Soldering Conditions

■ Reference for Manual Soldering

Series	Tip temperature	Soldering time	No. of solders
RKJXT1F, RKJXM, SLLB, SLLB5, SRBE, SKRH	350±5°C	3s max.	1 time

■ Reference for Dip Soldering

Series	Preheating		Dip soldering		No. of solders
	Soldering surface temperature	Heating time	Soldering temperature	Soldering time	
RKJXT1F, RKJXM	100°C max.	2 min. max.	260±5°C	5±1s	2 time max.

■ Example of Reflow Soldering Condition

1. Heating method: Double heating method with infrared heater.
2. Temperature measurement: Thermocouple ϕ 0.1 to 0.2 CA (K) or CC (T) at soldering portion (copper foil surface).
A heat resisting tape should be used for fixed measurement.
3. Temperature profile

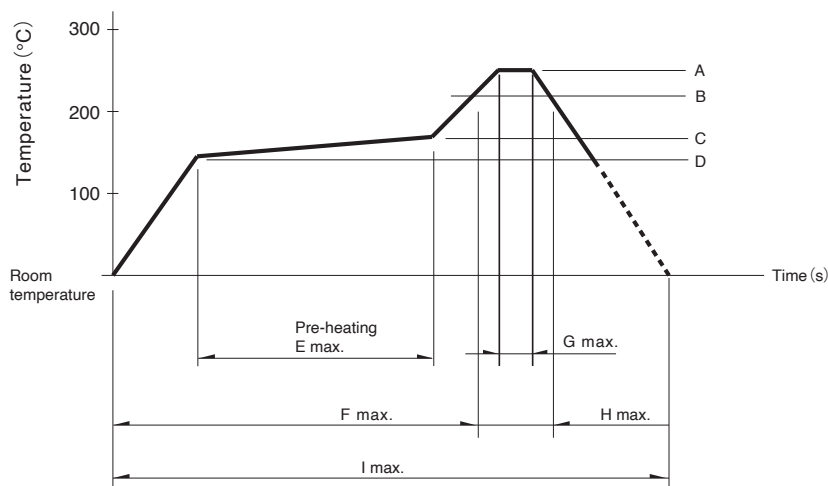

Series	A	B	C	D	E	F	G	H	I	No. of reflows
SLLB5	250°C	230°C	150°C	150°C	—	2 min.	—	30s	—	1 time
SKRH, SLLB, SRBE	260°C	230°C	180°C	150°C	2 min.	—	—	40s	—	1 time

⚠ Note

1. The above temperature shall be measured on the mounting surface of a PC board. There are cases where the PC board's temperature greatly differs from that of the switch, depending on the material, size thickness of PC boards and others. The above-stated conditions shall also apply to switch surface temperatures.
2. Soldering conditions differ depending on reflow soldering machines. Prior verification of soldering condition is highly recommended.

Switch Type Multi Control Devices / Cautions



1. Applying load to terminals during soldering under certain conditions may cause deformation and electrical property degradation.
2. Avoid use of water-soluble soldering flux, since it may corrode the switches.
3. Check and conform to soldering requirements under actual mass production conditions.
4. In soldering twice, make sure the solder joints should go down to normal temperature. Continuing heating will cause deformation of switch, loose and fractured terminals, or may deteriorate electrical characteristics.
5. Flux from around and above the PC board should not adhere to the switches.
6. For the sizes of holes and patterns on a PC board for mounting a switch, refer to the recommended dimensions in the outline drawings.
7. This switch is designed for manually operated units. Must not use this switch for a mechanical detection unit. For detection purposes, please use our detection switches.
8. After mounting the switches, if you intend to put the board into an oven in order to harden adhesive for other parts, please consult with ALPS.
9. Use of a through-hole PC board, or a PC board of different thickness from the recommendation will have a different heat stress. Verify the soldering requirements thoroughly before use.
10. Solder the switches with detent at the detent position. Soldering switches fixed at the center of the detent may deform the detent mechanisms.
11. No washing.
12. Protect small and thin switches from external forces in the set mounting process.
13. Use of the switches with voltage below 1V DC or current below $10\mu A$ may make contacts unstable.
When using these switches in this way, please consult with us beforehand.
14. The products are designed and manufactured for direct current resistance. Contact us for use of other resistances such as inductive (L) or capacitive (C).
15. The switch will be broken if impact force or a greater stress than that specified is applied. Take a great care not to let the switch be subject to greater stress than specified.
16. Do not apply a force from the side of the stem.
17. Be sure to push the center of switch for "without-stem" type. Extreme care is required for a hinge structure type because the stem press position moves when it is pressed.
18. Insert these switches to the specified mounting surface and mount them horizontally. If not mounted horizontally, these switches will malfunction.
19. Use of the switches in a dusty environment may lead the dusts entering through the openings and cause imperfect contact or malfunction. Take this into account for set design.
20. Corrosive gas if generated by peripheral parts of a set, malfunction such as imperfect contact may occur. Thorough investigation shall be required beforehand.
21. Be aware of dust intrusion into a non dust-proof-type TACT Switch™.
22. Storage
 1. Store the products as delivered, at a normal temperature and humidity, without direct sunshine and corrosive gas ambient. Use them at an earliest possible timing, not later than six months upon receipt.
 2. Store the key switches with the switch in the released position.

haptic reactor

● haptic reactor ————— 467

haptic reactor

List of Varieties

Series	AFT	AFR	AFDU
Photo			
Dimensions (mm)	10.0×22.6×9.0	23.0×33.0×13.0	10.0×19.0×5.0
Vibration Acceleration	3Gpp at 160Hz 2.28Gpp at 320Hz	15Gpp	4.9Gpp
Drive voltage	3V (square wave 3pulse)	6Vp-p (20 sine wave)	5.5Vp-p (30 sine wave)
Resonance frequency	160Hz (Low), 320Hz (High)	120Hz	175Hz
Operating temperature	-40°C to +85°C		
Resistance	8Ω±10% (@20°C)	10.2Ω±10% (@20°C)	6.5Ω±10% (@20°C)
Automotive	○	●	●

 **Note**

● Indicates applicability to all products in the series, while ○ indicates applicability to some products in the series.

AFT Series

Reproduces diverse tactile sensations through dual resonance with vibration.



 Automotive

※Please check the product list for compatible products

- Resonance frequency: 160Hz (Low), 320Hz (High)

Applications: Game: Home handheld consoles, Virtual/augmented reality
 Mobile: Headsets, wearables, Notebooks, peripherals
 Energy_Industrial: Industrial equipment, Robots, drones
 Home: Major home appliances
 Healthcare: Healthcare equipment
 Energy_Industrial: Robots, drones
 Automotive: Steering, Shifter, Navigation/audio systems, HVAC, Overhead consoles, Power Seats

■ Product List

Products No.	Vibration Acceleration	Drive voltagea	Operating temperature	Resistance	Size (mm)	Automotive	Drawing No.
AFT14A903A	3Gpp at 160Hz 2.28Gpp at 320Hz	3V (square wave 3pulse)	-40°C to +85°C	8Ω±10% (@20°C)	10.0×22.6×9.0	—	1
AFT14A906A	3Gpp at 160Hz 2.28Gpp at 320Hz	3V (square wave 3pulse)	-40°C to +85°C	8Ω±10% (@20°C)	10.0×22.6×9.0	●	2

⚠ Note

1. This catalog shows only outline specifications. When using the products, please obtain formal specifications for supply.
2. Please place purchase orders per minimum order unit (integer).

■ Packing Specifications

Tray

Number of packages (pcs.)		Export package measurements (mm)
1 case / Japan	1 case / export packing	
1,000	1,000	270×360×185

Drawing No.1

■ Dimensions

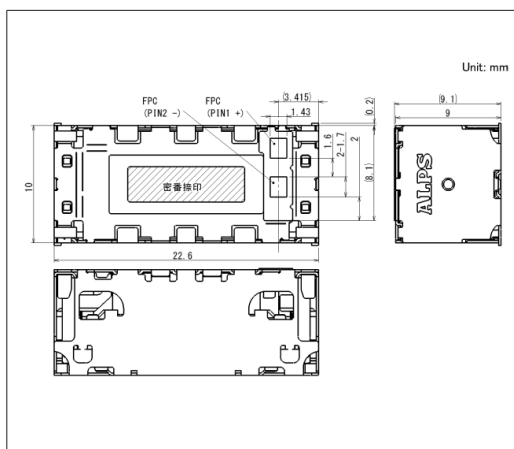

AFT Series

Drawing No.2

■ Dimensions

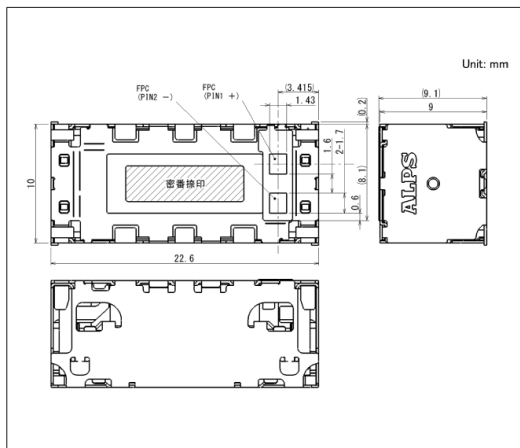

AFR Series

Automotive-compatible product delivering 15G of powerful vibration acceleration and clear click feel.

 Automotive

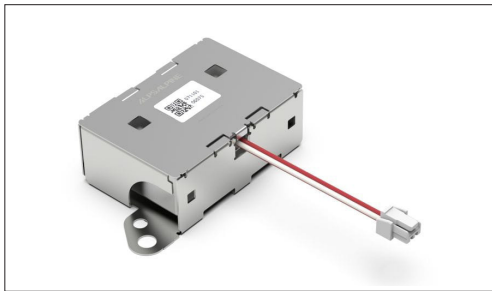

■ Resonance frequency: 120Hz

Applications: Energy_Industrial: Robots, drones, Industrial equipment
 Game: Home handheld consoles, Virtual/augmented reality
 Home: Major home appliances, Major home appliances
 Automotive: Steering, Shifter, Navigation/audio systems, HVAC

■ Product List

Products No.	Vibration Acceleration	Drive voltagea	Operating temperature	Resistance	Size (mm)	Automotive	Drawing No.
AFR14A901B	15Gpp	6Vp-p (20 sine wave)	-40°C to +85°C	10.2Ω±10% (@20°C)	23.0×33.0×13.0	●	1

 Note

1. This catalog shows only outline specifications. When using the products, please obtain formal specifications for supply.
2. Please place purchase orders per minimum order unit (integer).

■ Packing Specifications

Tray

Number of packages (pcs.)		Export package measurements (mm)
1 case / Japan	1 case / export packing	
200	200	270×360×185

Drawing No. 1

■ Dimensions

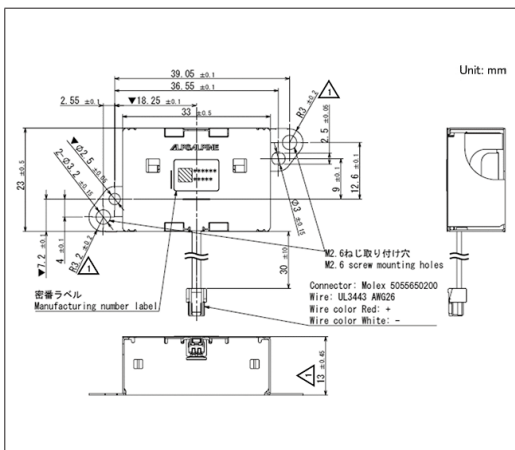

AFDU Series

Automotive-compatible product with compact size and strong vibration acceleration.

 Automotive

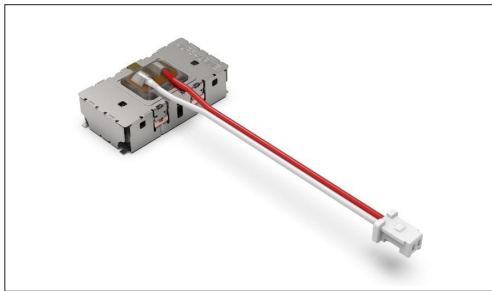

■ Resonance frequency: 175Hz

Applications: Energy_Industrial: Robots, drones, Industrial equipment
 Game: Home handheld consoles, Virtual/augmented reality
 Home: Major home appliances, Major home appliances
 Automotive: Steering, Shifter, Navigation/audio systems, HVAC

■ Product List

Products No.	Vibration Acceleration	Drive voltagea	Operating temperature	Resistance	Size (mm)	Automotive	Drawing No.
AFDU1A031A	4.9Gpp	5.5Vp-p (30 sine wave)	-40°C to +85°C	6.5Ω±10% (@20°C)	10.0×19.0×5.0	●	1

 Note

1. This catalog shows only outline specifications. When using the products, please obtain formal specifications for supply.
2. Please place purchase orders per minimum order unit (integer).

■ Packing Specifications

Tray

Number of packages (pcs.)		Export package measurements (mm)
1 case / Japan	1 case / export packing	
600	600	270×360×185

Drawing No. 1

■ Dimensions

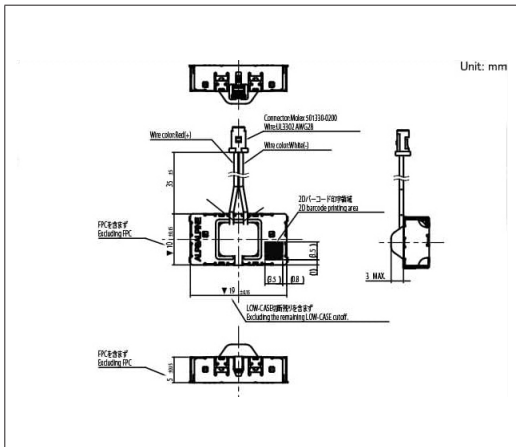

Connectors

● Spring Contact ————— 473

Spring Contact

List of Varieties

Series	SCTA_A
Photo	
Ratings	3A/5V
Mounting type	Surface mounting type
Dimensions (mm)	1.4×1.4
Product height (mm)	1.2 1.4 1.6 1.8 2.0
Operating temperature range	-30°C to +85°C
Rated current	3A
Contact resistance (Initial)	Connector contacts 40mΩ max.
Stroke Frequency	500 times
Automotive	—

Connectors Spring Contact

Standard Type SCTA_A Series

Suitable for various electrical connections such as signal, ground, and antenna.



- Mounting type: Surface mounting type
- Rated current: 3A
- Operating temperature range: -30°C to +85°C

Applications: Mobile: Smartphones, tablets, Headsets, wearables,
Notebooks, peripherals
Game: Home handheld consoles
Healthcare: Healthcare equipment

■ Product List

Products No.	Dimensions(WXD) (mm)	Product height (mm)	Height in use (mm)	Automotive	Drawing No.
SCTA1A0100	1.4x1.4	1.2	0.7 to 1.0	—	1
SCTA2A0100	1.4x1.4	1.4	0.8 to 1.2	—	2
SCTA3A0103	1.4x1.4	1.6	1.0 to 1.4	—	3
SCTA4A0100	1.4x1.4	1.8	1.2 to 1.6	—	4
SCTA5A0101	1.4x1.4	2.0	1.4 to 1.8	—	5

⚠ Note

1. This catalog shows only outline specifications. When using the products, please obtain formal specifications for supply.
2. Please place purchase orders per minimum order unit (integer).

■ Packing Specifications

Taping

Products No.	Number of packages(pcs.)			Tape width (mm)	Export package measurements (mm)
	1 reel	1 case / Japan	1 case / export packing		
SCTA1A0100	15,000	45,000	90,000	8	403x403x167
SCTA2A0100	13,000	39,000	78,000	8	403x403x167
SCTA3A0103	12,000	36,000	72,000	8	403x403x167
SCTA4A0100	11,000	33,000	66,000	8	403x403x167
SCTA5A0101	10,000	30,000	60,000	8	403x403x167

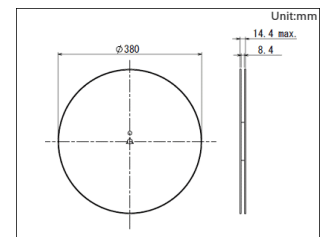

Standard Type
SCTA_A Series

Drawing No.1

■ Dimensions

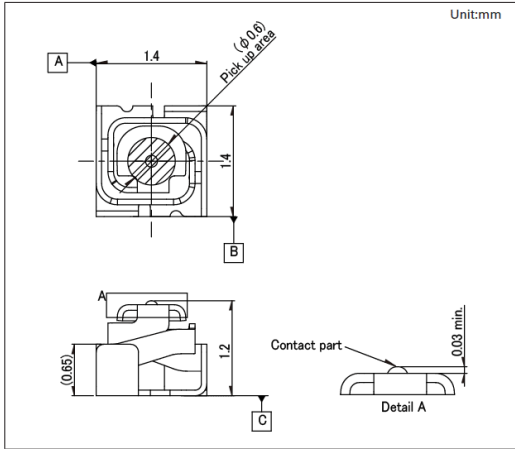

■ Land Dimensions

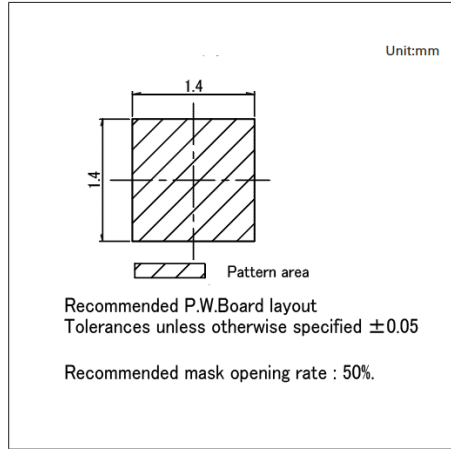

Drawing No.2

■ Dimensions

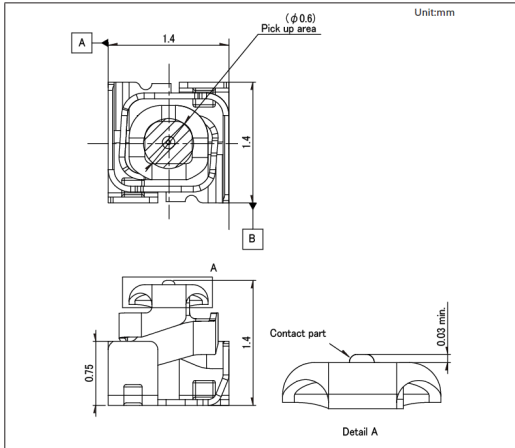

■ Land Dimensions

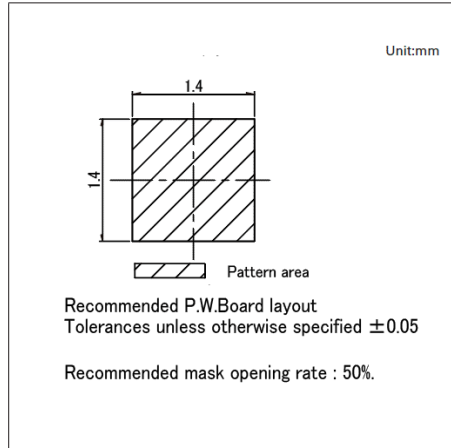

Drawing No.3

■ Dimensions

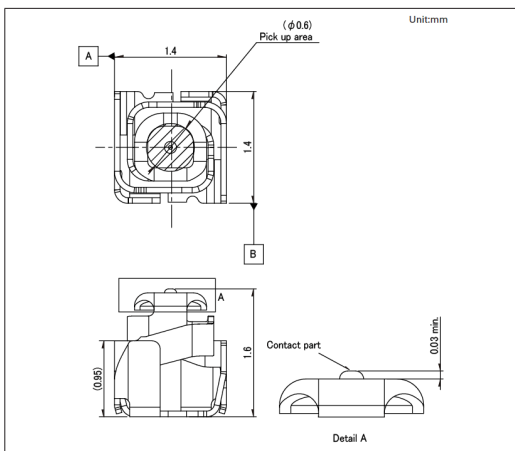

■ Land Dimensions

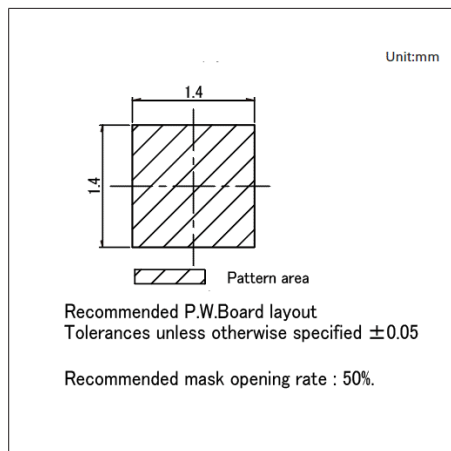

Drawing No.4

■ Dimensions

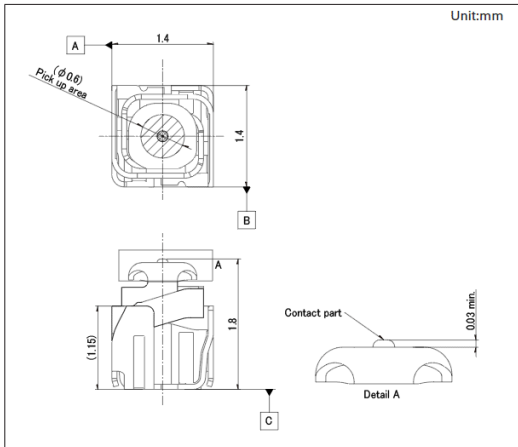

■ Land Dimensions

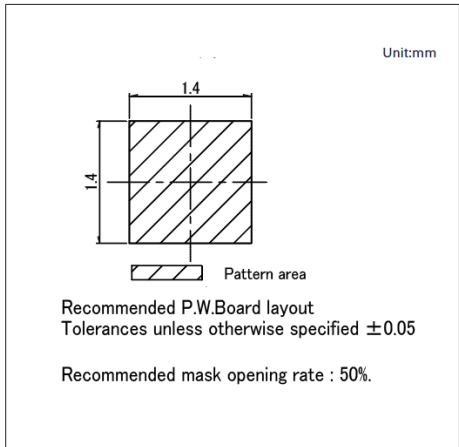

Drawing No.5

■ Dimensions

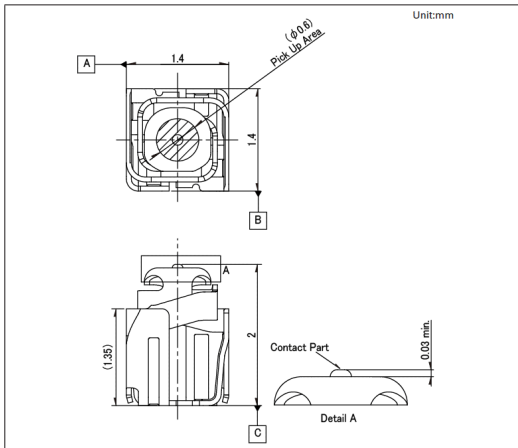

■ Land Dimensions

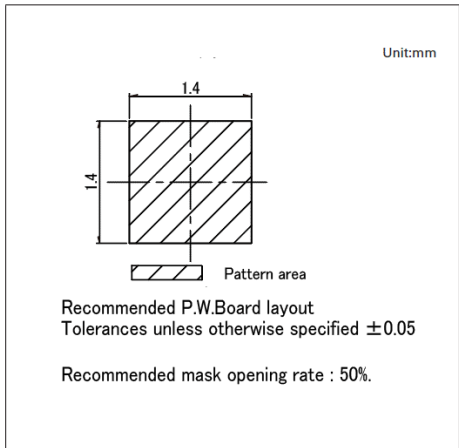

Explanation of Terms

● Explanation of Terms ————— 478

Explanation of Terms

Some typical terms used in this catalog are explained below for your information.

■ General

Switchover Timing

● Shorting

Circuit switchover is carried out after electrical connections are once established between terminals.

[Example]

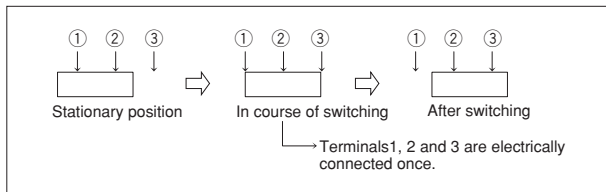

● Non-shorting

Circuit switchover is carried out after electrical connections between terminals are shut down once.

[Example]

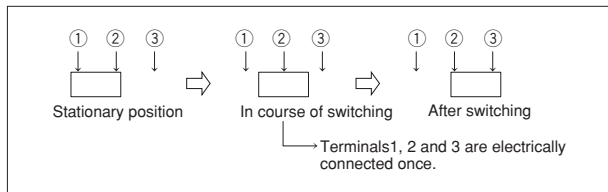

Contact Structure

● Sliding Contact

Sliding contacts are constructed so that an insulator between contacts (a fixed contact and a movable contact) is removed by mechanical friction to keep the contact surface clean. Excellent for very low currents.

● Double-side Sliding

Sliding contact with fixed contact holding movable contact at both side.

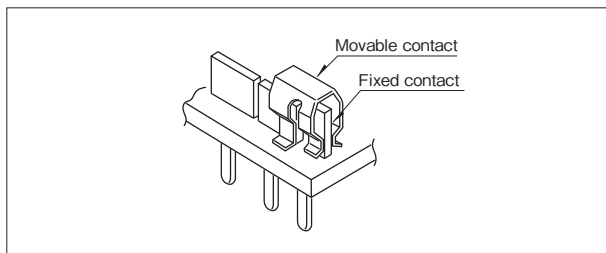

● Single-side Sliding

Sliding contact with fixed contact holding movable contact at one side.

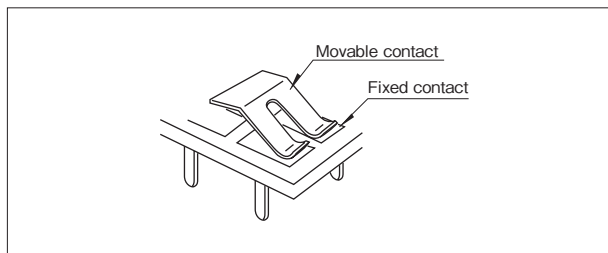

How to View the Circuit Diagram of Switch

The following circuits are mainly used in switches. The switch for very low current is expressed as □□ poles

SPST (Single Pole Single Throw)	SPDT (Single Pole Double Throw)	DPST (Double Pole Single Throw)	DPDT (Double Pole Double Throw)

Snap-in

With kink-shaped terminals or frames, this is of a structure that keeps the switch from falling off after insertion into the PC board. We create a form that fits into a 1.6mm thick PC board, which is our standard.

Explanation of Terms

Taping (Packaging)

Delivery type, radial or embossed packaging.

- Embossed Taping

A polymer tape for packaging chips with emboss for automatic mounting.

- Radial Taping

A packaging method for automatic insertion; parts are mounted in a specified position on paper tape.

Soldering Method

- Dip (Soldering)

A soldering method by moving PC board over flowing molten solder.

- Reflow (Soldering)

A soldering method for surface mounting; the entire board and part are soldered by cream soldering, etc. without using molten solder.

■ Slide Switches

Operation Mode

- Recoil

So that a key pushed to one side only stays in that position as long as it is held, a recoil mechanism is used to allow it to return to its original position when the force is released. There are three types depending on the direction the key is pushed: a left-side recoil for products operated only to the left; a right-side recoil for products operated only to the right; and a double-side recoil for products operated in both directions.

■ Push Switches

Operation Mode

- Latching

The switch stays On when the control knob is pushed and the knob locks in the pushed-in position. When pushed again, the switch unlocks and turns Off, with the control returning to its original position.

- Momentary

The switch stays On only as long as the control knob is pushed. Stop pushing and the switch turns Off as the knob returns to its original position.

- Alternate

The switch stays On when the control knob is pushed, but the knob returns to its original position. When pushed again, the switch turns Off and the knob again returns to its original position.

The knob's returning to its original position in both On and Off states is how this action differs from latching.

■ TACT Switch™

Click (Tactile Feedback)

The feel indicated by the portion of each of the load – travel graphs on the next page where the curve turns back. The greater this inversion portion is, the clearer it is to the operator that the switch has been activated.

{Sharp Feeling}

A sharp tactile feel corresponding to a feel of a metal spring type is obtainable. The travel is generally short, about 0.1 to 0.3mm.

{Soft Feeling}

A soft smooth tactile feedback feel corresponding to a feel of rubber spring type is obtainable. The travel is generally 1-2 mm.

Explanation of Terms

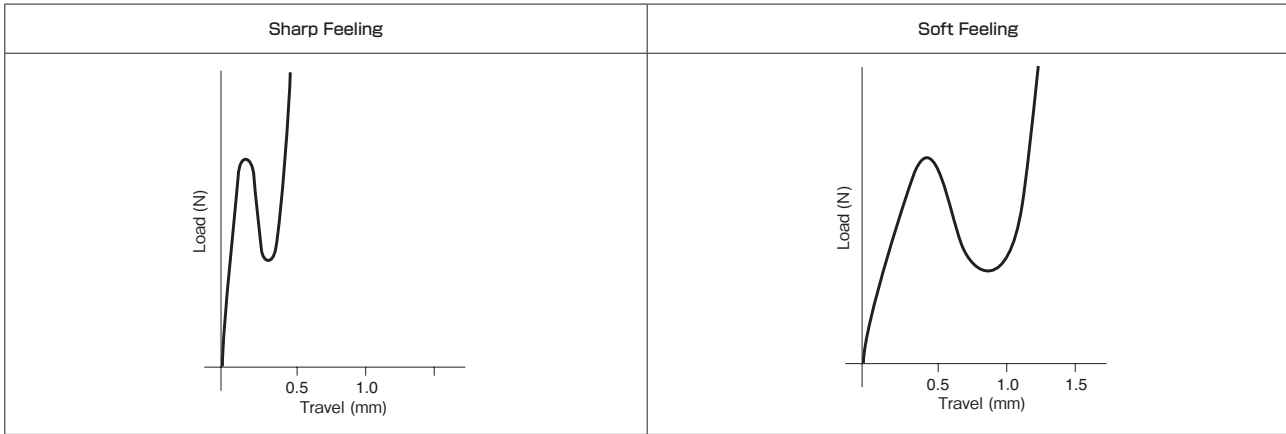

Double Action

A structure that closes the first stage of the circuit with a light press on the switch and then closes the second stage of the circuit with a stronger press. A double-action switch is a keyswitch with two switch functions. Our SKRN, SKSD and SKTC series are an example of this feature.

Variety

The "Vertical Type" switch is operated by pressing it at right angles to the PC board. The "Horizontal Type" switch is operated by pressing it in parallel to the surface of the PC board.

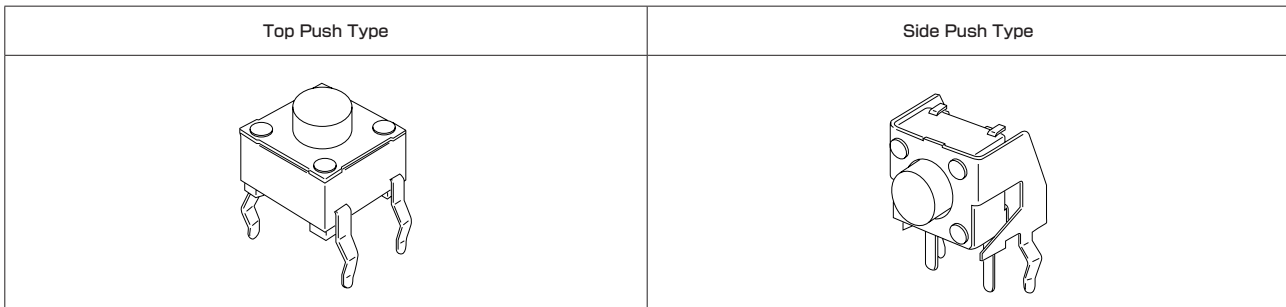

(Part Names of the TACT Switch™)

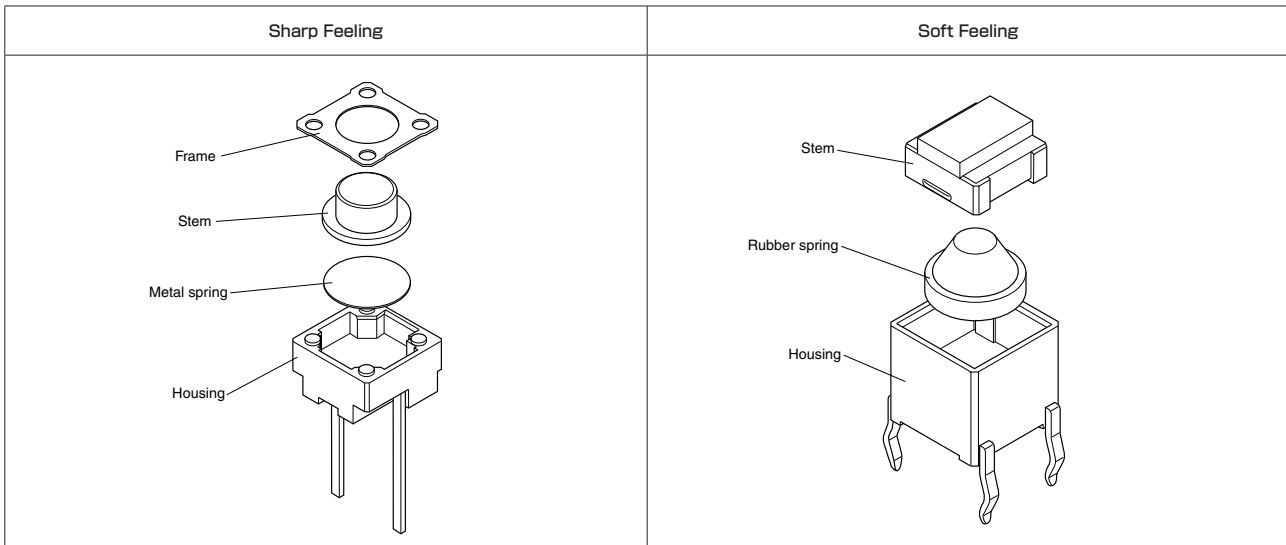

Explanation of Terms

Encoder

The rotation or travel of the operating shaft (operating knob) is output digitally as an electric signal. The encoder shown in this catalog is composed of a sliding contact and a pattern switch.

Output Example of Absolute System

A type of encoder whose output consists of a code representing an absolute position, where different codes are assigned to each position. Rotary type encoders mainly employ Gray codes to indicate the shaft's current position.

Output example for an absolute type (Gray code) encoder

Position	1	2	3	4	5	6	7	8	9	10	11	12	
Gray Code	1		ON	ON			ON	ON			ON	ON	
	2			ON	ON	ON	ON					ON	ON
	3					ON	ON	ON	ON	ON	ON	ON	ON
	4								ON	ON	ON	ON	

Output Example of Incremental System

Indicates a system which outputs the 2 different pulses (having phase differences) of the output timing. The pulses are output only to the extent where the shaft of the encoder is rotated and the direction of rotation is identified by phase differences.

Output example of incremental system

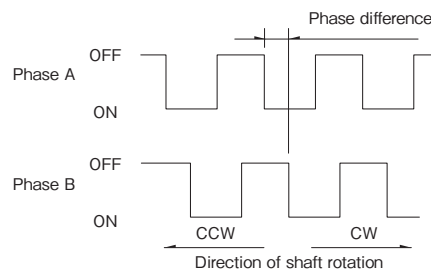

Rotational Torque

Torque to turn the operating shaft (operating knob) .

Detent (-type)

Mechanism that provides click feel during operation.

Detent Torque

The torque required to rotate the control shaft (knob) of a potentiometer which has a detent.

Maximum Resolution

Number of bits in case of an absolute-type encoder or number of pulses per rotation in case of an incremental-type encoder.

Allowable Force in Push-pull Action for Shaft (Lever)

Maximum force at which the control part can endure without being broken when axial load is applied to the shaft (lever) .

Insulation Resistance

The insulation between the active part (terminal) and the body or shaft (lever) of the product is expressed as the resistance value. The larger the value, the higher the insulation.

Explanation of Terms

Self-return Switch

Rotary switch that turns ON when the shaft is rotated either way; when it is released, the shaft automatically returns to the center position, which turns OFF.

Knurl (Serration)

Shape of the encoder shaft. Regular crest pattern is formed on the outer circumference of shaft for fitting with the knob.

Withstand Voltage

This is the voltage at which the insulation between the active part of the product and the insulated body or shaft (lever) is destroyed.

Push Momentary

A momentary switch that is on only when the shaft is pressed.

■ Potentiometers

Allowable Operating Force

Maximum operating force that the lever can endure without breakage, when it is turned to full CW or CCW position.

Rotational Torque

Torque to turn the operating shaft (operating knob) .

Detent (-type)

Mechanism that provides click feel during operation.

Detent Torque

The torque required to rotate the control shaft (knob) of a potentiometer which has a detent.

Derating Curve

Curve that shows the relationship between the ambient temperature and maximum power. (Unit: percentage to rated power)

Nominal Total Resistance

Resistance value that represents the specified values (reference resistance) .

Maximum Allowable Operating Voltage

Maximum voltage applicable to the resistor specified for the potentiometer type.

Maximum Attenuation Level

Ratio of voltage between terminal 1 and terminal 2 (or between terminal 2 and terminal 3) in relation with the voltage applied to both ends of the resistor when the operating shaft (operating knob) is in its full CW or CCW position. (Unit: decibels)

Allowable Operating Torque

Maximum operating torque that the operating shaft (operating knob) can endure in its full CW or CCW position.

Operating Force

Force to operate the control part.

Residual Resistance

Resistance (value) between the end terminal (terminal 1 or terminal 3) and the sliding terminal (terminal 2) when the control shaft (control part) is in its full CW or CCW position.

Explanation of Terms

Shaft (Lever) Play

Play (tilt) of the shaft (lever) when a specified force is applied perpendicular to the shaft (lever) .

Shaft Tilt

Parallel or perpendicular shift from the axial line or mounting surface with no load applied to the shaft, assuming the potentiometer mounting surface as reference.

Chassis Stopper

Boss provided on a chassis in order to prevent unintentional rotation for a purpose of positioning a rotary potentiometer during assembly.

Sliding Noise

Electrical noise that is generated when a potentiometer is operated, expressed as voltage or resistance ratio.

Insulation Resistance

The insulation between the active part (terminal) and the body or shaft (lever) of the product is expressed as the resistance value. The larger the value, the higher the insulation.

Total Rotational Angle

Rotational angle of the operating shaft between both ends.

Center Detent

A detent positioned at a potentiometer's center of full rotation.

Total Resistance and Tolerance

A basic performance item of a potentiometer. Resistance between terminal 1 and terminal 3 and its tolerance.

Gang Error

Gap between respective resistance tapers of several potentiometers that make up a multi-ganged-type potentiometer.(Unit:decibel)

Moisture Load Life

Variation of the electrical characteristics of a potentiometer when a test piece is allowed to stand under specified temperature and humidity conditions for many hours and is then returned to normal temperature and humidity conditions.

Dummy Terminal

Terminal that does not function electrically.

□-terminal

When describing the terminal numbers of a potentiometer, the terminals connected to both ends of a resistor element are called terminal 1 and terminal 3. The terminal connected to the sliding contact is called terminal 2.

Carbon Film (Resistor)

Resistance element that is formed from a carbon-base film and used for general-purpose potentiometers.

Mounting Height

Height from the surface of the PC board to the top of the shaft when a rotary potentiometer is soldered on the board.

Load Life

Tolerance of the electrical characteristics after applying a voltage that is equivalent to rated power between specified terminals of a potentiometer for a specified period under certain temperature.

Push Momentary

A momentary switch that is on only when the shaft is pressed.

Explanation of Terms

Push-and-lock

A product type that can be locked with the shaft pushed to house the control part (knob) in the set body when the product is set and no more operated.

Printed Circuit Terminal

This is a terminal to be inserted in the mounting hole of a PW board and soldered.

Resistance Taper

Characteristics that indicate the change in the resistance or output voltage of a potentiometer in reference with travel.

Eccentricity

Deviation in the position of the shaft or lever from the original reference position (deflection).

Lug Terminal

A conductive metal terminal used for joining wires.

Precautions when handling our products

1. For the export of products which are controlled items subject to foreign and domestic export laws and regulations, you must obtain approval and/or follow the formalities of such laws and regulations.
2. Products must not be used for military and/or antisocial purposes such as terrorism, and shall not be supplied to any party intending to use the products for such purposes.
3. Unless provided otherwise, the products have been designed and manufactured for application to equipment and devices which are sold to end-users in the market, such as AV (audio visual) equipment, home electric equipment, office and commercial electronic equipment, information and communication equipment or amusement equipment.
The products are not intended for use in, and must not be used for, any application of nuclear equipment, driving control equipment for aerospace or any other unauthorized use.
With the exception of the above mentioned banned applications, for applications involving high levels of safety and liability such as medical equipment, burglar alarm equipment, disaster prevention equipment and undersea equipment, please contact an Alps Alpine sales representative and/or evaluate the total system on the applicability.
Also, implement a fail-safe design, protection circuit, redundant circuit, malfunction protection and/or fire protection into the complete system for safety and reliability of the total system.
4. Before using products which were not specifically designed for use in automotive applications, please contact an Alps Alpine sales representative.

Cautions for using this catalog

1. This catalog shows only outline specifications. When using the products, please obtain formal specifications for supply.
2. The colors of the products in the catalog may slightly differ from those of the actual products.
3. The external appearance, functions and other specifications herein may be changed for improvement and other reasons without prior notice. Furthermore, the products herein may discontinue without prior notice.
4. TACT Switch, Contactsheet, ThumbPointer, SENSORING are trademarks or registered trademarks of ALPS ALPINE CO., LTD. in Japan.
5. Bluetooth is a registered trademark of Bluetooth SIG Inc. and licensed to ALPS ALPINE CO., LTD.
6. All product names, company names and names of standards described in this catalog are trademarks or registered trademarks of their respective owners.

ALPSALPINE
extends your senses

ALPSALPINE CO., LTD.

Visit the Alps Alpine website
for the latest product information.

www.alpsalpine.com

Copyright © 2025 ALPS ALPINE CO., LTD.

